

ZS-52D

Spindle Unit Replacement Instructions

<Target Model>
DWX-52D

⚠WARNING Before performing replacement work, switch off the machine's power switch and pull out the power cord from the machine.

Attempting such operations while the machine is connected to a power source may result in injury or electrical shock.

⚠CAUTION Be sure to perform operations as specified by these instructions, and never touch any area not specified in the instructions.

Sudden movement of the machine may cause injury or burns.

⚠CAUTION Do not touch the spindle unit or the surrounding areas immediately after milling has ended.



Doing so may result in burns.

⚠CAUTION Remove the milling tool before performing replacement work.

Contact with the blade may cause injury.

Contents

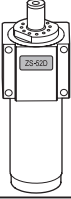
This product contains the following items. Make sure they are all present and accounted for.

		
Spindle unit (1)	Belt (1)	Pin (1)

Item Used in Replacement Work

The T-shaped hexagonal screwdriver included with the DWX will be used during spindle replacement work, so prepare this item.

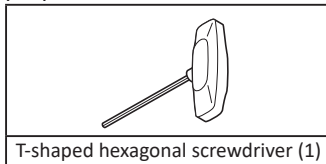

Replacement Procedure

1. Carry out the preparations for the replacement.

① Switch on the machine's power switch.

If the milling bur is attached to the spindle unit, press the operation button on the machine after it turns on. The milling bur will return to the ATC magazine.

② Display VPanel.

Click the VPanel icon in the task tray. VPanel will appear.

If VPanel is not displayed correctly, check the instruction manual included with the machine.

③ Select the machine whose spindle will be replaced.

① In the top window of VPanel, select the machine to operate.

When you have connected multiple machines, you can switch between the machines by clicking their icons.

② Click .

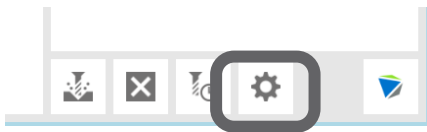

The [Settings] window is displayed.

④ Adjust the spindle unit position.

① Click the [Maintenance] tab.

② Click [Open collet].

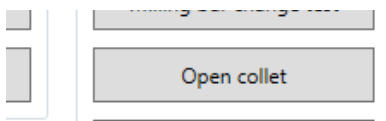

③ Click [OK].

The spindle unit will move to the prescribed location, which will open the collet.

④ When the operation completion window appears, click [OK].

5 Open the front cover.

6 Insert the pin into the spindle unit.

Insert the pin until it reaches the end.

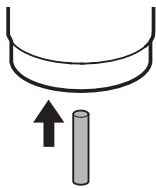

If the pin falls out, secure it with tape or a similar method.

7 Click [Spindle replacement].

The spindle unit will move.

8 Switch off the machine's power switch, and then pull out the power cord from the machine.

2. Remove the spindle unit.

1 Open the maintenance cover.

First open the front cover, and then open the maintenance cover.

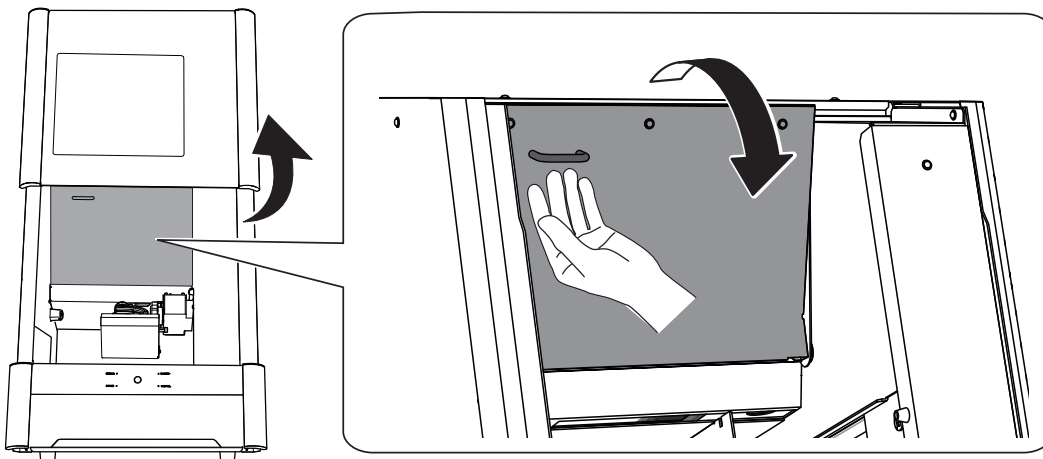

2 Check that the "ZS-52D" label is affixed to the spindle.

If it is not, the existing spindle cannot be replaced with this one. Stop the work.

3 Loosen the screws securing the motor stay.

Loosen the screws by about two turns.

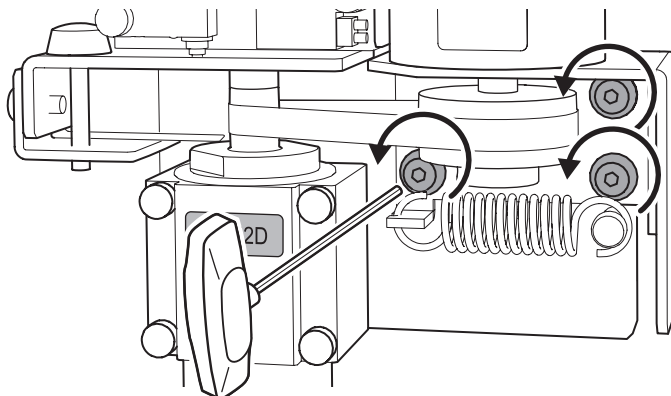
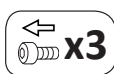

4 Remove the belt from one side.

- ① Press the part shown in the figure with your finger.
- ② Remove the belt from the motor pulley, and then release part ① pressed with your finger.

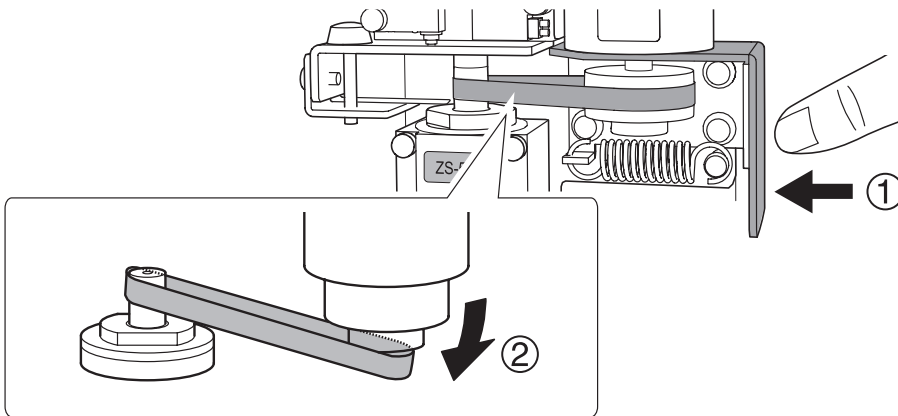

5 Remove the spindle unit.

Remove the screws, and then slowly pull both the spindle belt and the spindle unit straight out.

CAUTION Make sure the belt is not pinched behind the spindle unit.
Make sure the spindle unit does not come into contact with the conductive plate.

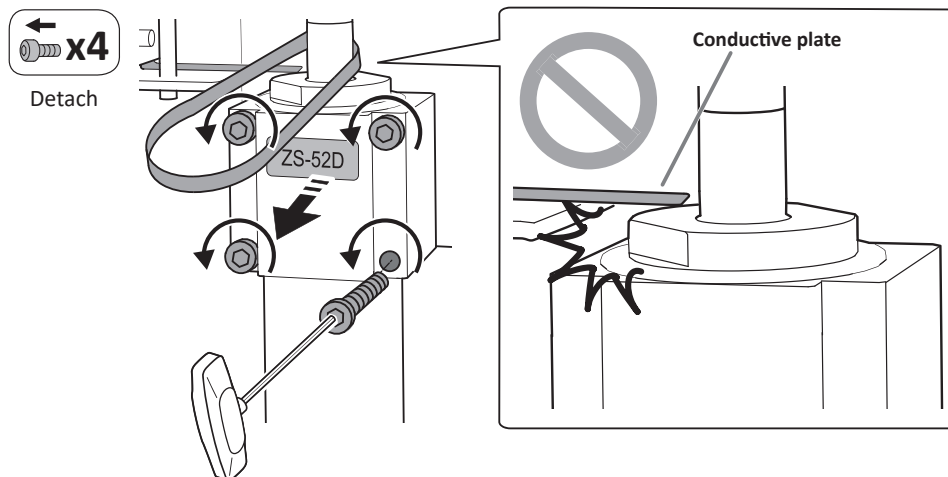

3. Attach the new spindle unit.

- ① Use tape or a similar method to secure the pin attached to the new spindle.

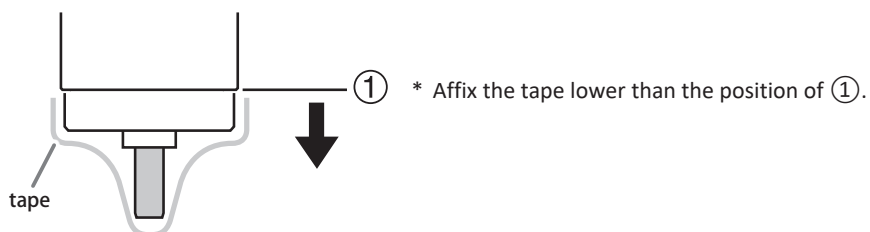

2 Set the belt onto the spindle unit.

Using the included new belt, make sure the white line is on the outside of the belt.

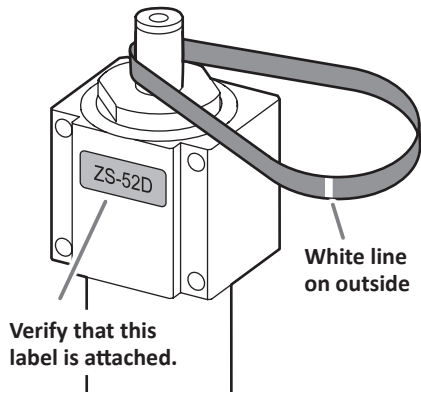

3 Attach the spindle unit.

Set the spindle unit onto the pins.

CAUTION

Make sure the belt is not pinched behind the spindle unit.
Make sure the spindle unit does not come into contact with the conductive plate.

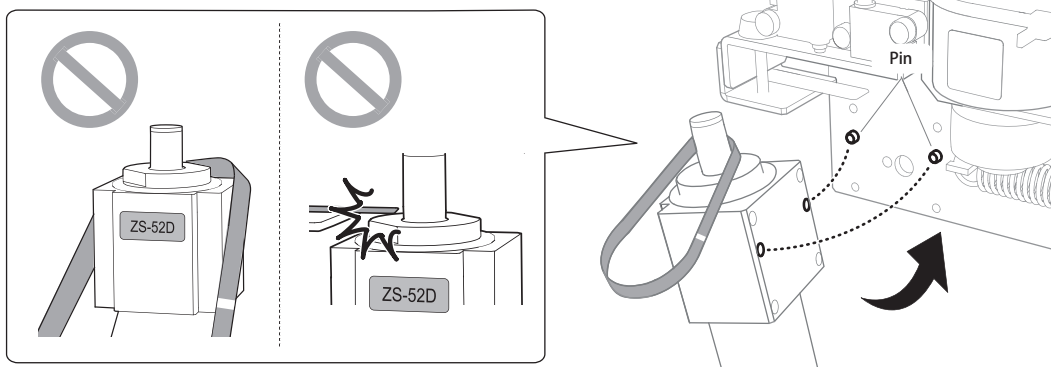

4 Secure the spindle unit.

Secure the spindle unit with the screws.

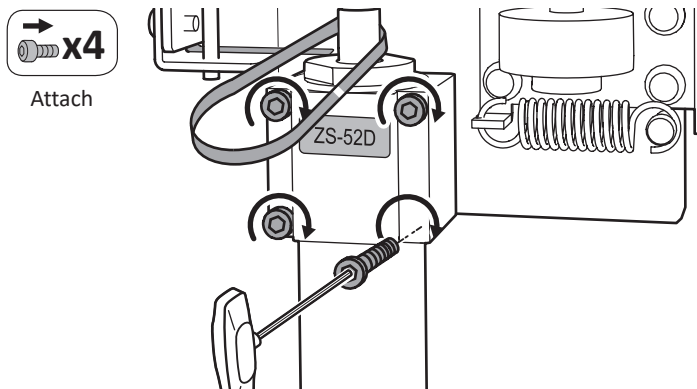

5 Set the belt on the motor pulley.

① Press the part shown in the figure with your finger.

- ② Set the belt on the motor pulley, and then release part ① pressed with your finger.

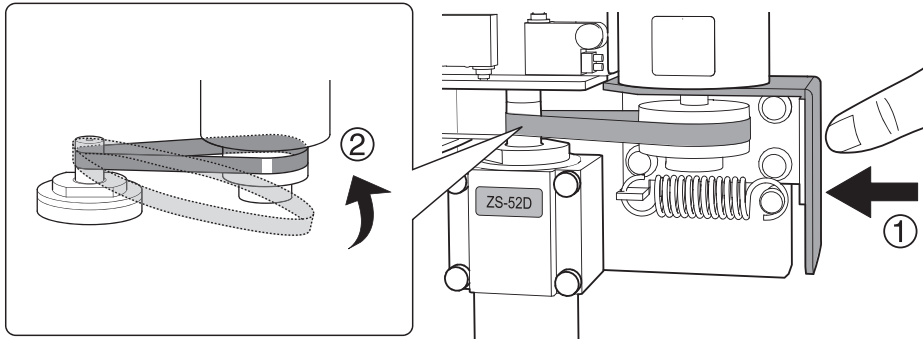

- ⑥ Adjust the belt position.

Rotating the motor pulley will cause the belt to move.

Rotate the pulley back and forth to adjust the belt to the position in the figure below.

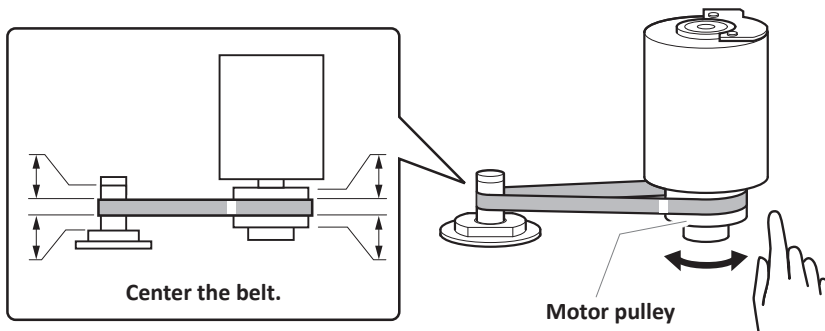

- ⑦ Secure the motor stay.

Tighten the screws.

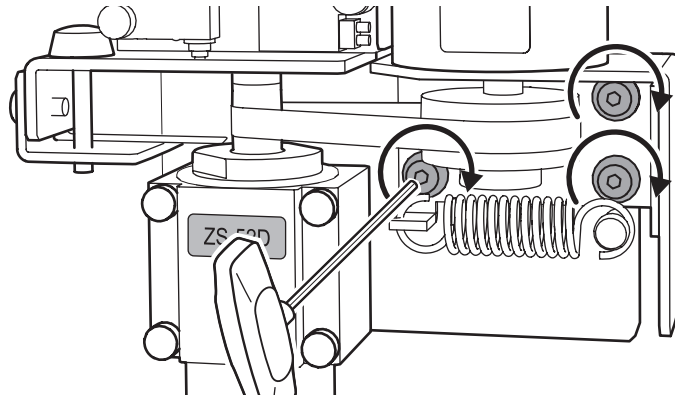

4. Adjust the position of the conductive plate.

- ① Check the position of the conductive plate.

Verify the following 3 points. If all points have been met, go to step ②.

If any point has not been met, go to step ②.

1. The conductive plate and the spindle unit are not in contact with each other.
2. The conductive plate and the spindle unit do not come into contact with each other or produce abnormal noise when the motor pulley rotates.

3. The distance between the conductive plate and the spindle unit is 0.7 mm (27.55 mil) or less. (For your reference, the conductive plate is 0.2 mm [7.87 mil] thick.)

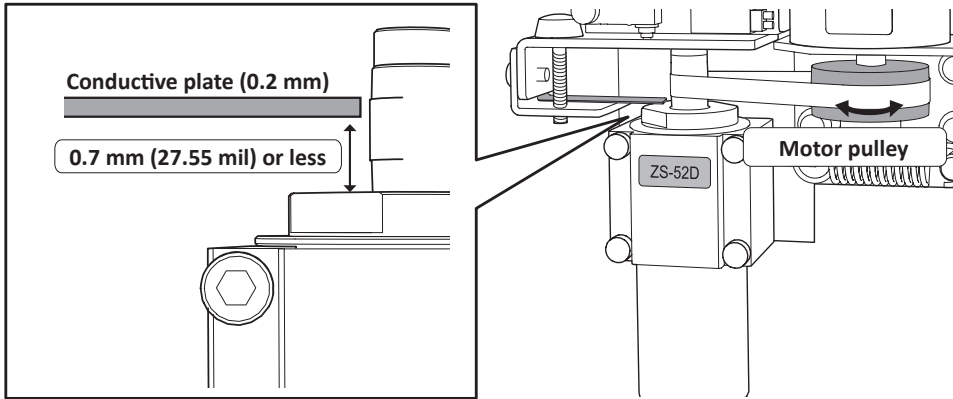

2 Adjust the position of the conductive plate.

① Loosen the screw.

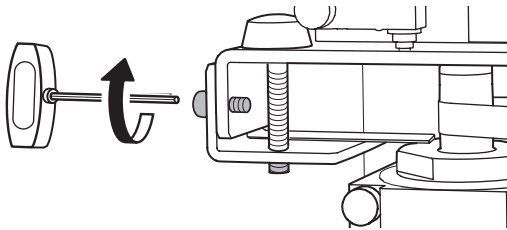

② Turn the adjustment screw in the counterclockwise direction until the conductive plate and the spindle unit are in contact with each other.

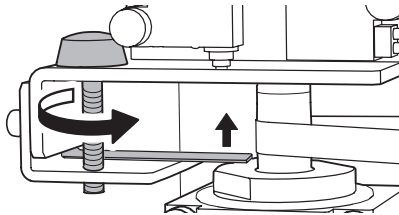

③ Rotate the adjustment screw through one full clockwise turn.

④ Tighten the screw that you loosened in step ①.

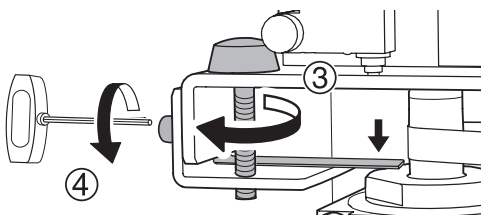

3 Verify that the conductive plate is in a position that meets the requirements in step 1.

4 Close the maintenance cover, and then close the front cover.

5 Connect the power cord, and then turn on the machine's power switch.

6 Adjust the spindle unit position.

① Display VPanel, and then click .



② Click the [Maintenance] tab.

- 3 Click [Open collet].

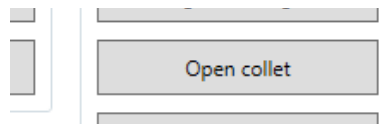

- 4 Click [OK].

The spindle unit will move to the prescribed location, which will open the collet.

- 5 When the operation completion window appears, click [OK].

- 7 Open the front cover.

- 8 Pull out the pin from the attached spindle unit.

Remove the tape before pulling out the pin.

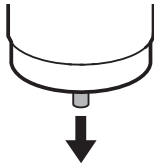

- 9 Click [Close collet].

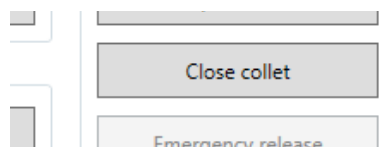

- 10 Click [OK].

The spindle unit will move to the prescribed location.

This step is complete once the work completion message appears.

5. Perform operations after replacing the spindle unit.

- 1 Reset the work time of the spindle unit.

- 1 Display VPanel, and then click .

- 2 Click the [Maintenance] tab, and then click [Reset].

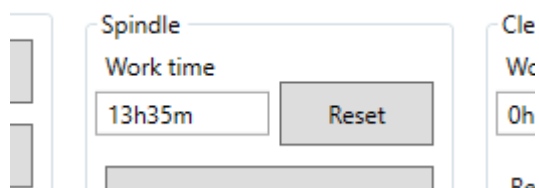

- 2 Run-in the spindle unit.

Failure to run-in the spindle may result in unstable spindle rotation. Refer to the manual included with the milling machine for instructions on how to perform the work.

Check for abnormal noise during run-in.

If abnormal noise is generated, the conductive plate may be in contact with the spindle. Start over from step 2 in section 4.

- 3 Perform automatic correction of the milling machine.

If automatic correction is not performed, the cutting results may be undesirable. Refer to the manual included with the milling machine for instructions on how to perform the work.