

**SOLJET PRO4**

# **XR-640**

## **USER'S MANUAL**

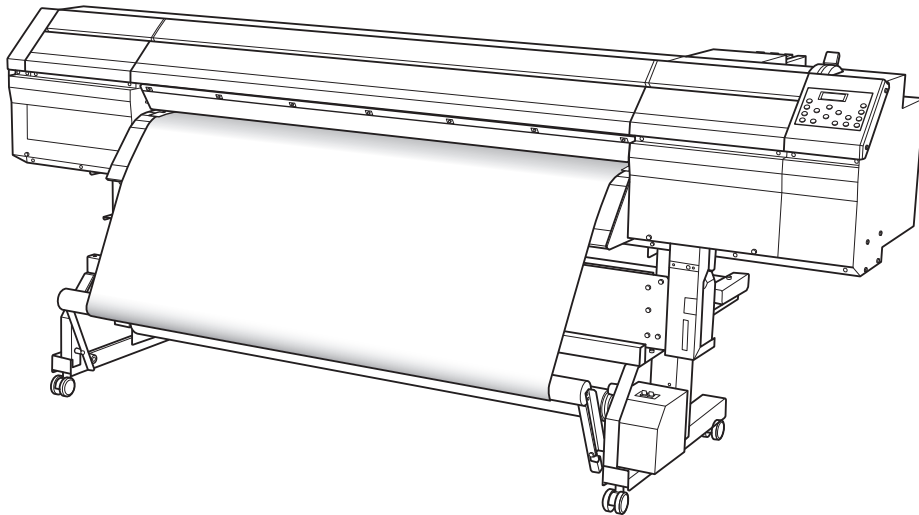

---

Thank you very much for purchasing this product.

- To ensure correct and safe usage with a full understanding of this product's performance, please be sure to read through this manual completely and store it in a safe location.
- Unauthorized copying or transferral, in whole or in part, of this manual is prohibited.
- The contents of this document and the specifications of this product are subject to change without notice.
- The documentation and the product have been prepared and tested as much as possible. If you find any misprint or error, please inform us.
- Roland DG Corp. assumes no responsibility for any direct or indirect loss or damage which may occur through use of this product, regardless of any failure to perform on the part of this product.
- Roland DG Corp. assumes no responsibility for any direct or indirect loss or damage which may occur with respect to any article made using this product.

---

**Roland DG Corporation**

This product is using GNU General Public License (GPL) / GNU Lesser General Public License (LGPL) software. You have the right to acquire, modify, and distribute the source code for this GPL/LGPL software. You can obtain the GPL/LGPL source code used in this product by downloading it from the following website.  
URL: <http://www2.rolanddg.com/gpl/>

# Contents

|   |           |
|---|-----------|
| Contents .....  | 1         |
| <b>Chapter 1 Machine Highlights .....</b>   | <b>5</b>  |
| Part Names and Functions .....  | 6         |
| Printer Unit.....   | 6         |
| Operation Panel .....   | 8         |
| Media Take-up System.....   | 9         |
| Menu List.....  | 10        |
| Main Menu.....  | 10        |
| Language and Unit Menu.....   | 13        |
| Cleaning Menu .....   | 14        |
| Heater Configuration Menu.....  | 14        |
| Cutting Configuration Menu.....   | 14        |
| <b>Chapter 2 Basic Operation.....</b>   | <b>15</b> |
| Prepare the Media.....  | 16        |
| Type of Media .....   | 16        |
| Usable Media .....  | 17        |
| Switch On!.....   | 18        |
| Switch On!.....   | 18        |
| The Power-saving Feature (Sleep Mode) .....   | 18        |
| Loading Media .....   | 19        |
| Loading Roll Media .....  | 19        |
| Loading the Sheet Media .....   | 27        |
| Performing the Initial Adjustment (Correcting for Misalignment in Bidirectional Printing More Precisely)..... | 29        |
| Setup of Media .....  | 31        |
| About [Media Setting] menu .....  | 31        |
| Setup of Media ([Media Setting] menu).....  | 31        |
| Outputting.....   | 42        |
| Setting the Output-start Location.....  | 42        |
| Printing Tests and Normal Cleaning .....  | 43        |
| Important Note on Cutting.....  | 45        |
| Setting The Cutting Test And The Blade Force .....  | 46        |
| Getting Ready to Receive Data from a Computer .....   | 47        |
| Starting Output .....   | 48        |
| Pausing and Canceling Output .....  | 49        |
| Cutting Off the Media.....  | 49        |
| Switch Off.....   | 51        |
| Switch Off.....   | 51        |
| <b>Chapter 3 Maintenance: For always using the printer in the best condition .....</b>                        | <b>52</b> |
| Checking for Remaining Ink and Replacing Cartridges .....   | 53        |
| Checking for Remaining Ink .....  | 53        |
| How to Replace Ink Cartridges .....   | 54        |
| Maintenance that Should Be Performed Daily .....  | 55        |
| Disposing of Discharged Fluid.....  | 55        |
| Cleaning.....   | 57        |
| About Care and Maintenance of Print Heads.....  | 58        |
| When Normal Cleaning Is Not Effective .....   | 59        |

|   |           |
|---|-----------|
| Medium Cleaning .....   | 59        |
| Powerful Cleaning .....   | 60        |
| Manual Cleaning of Print Heads .....  | 61        |
| When Manual-Cleaning Becomes Necessary .....  | 61        |
| Manual Cleaning of Print Heads .....  | 62        |
| When Problems Such As Dot Drop-out are Not Cleared Up .....                         | 66        |
| When Problems Such As Dot Drop-out are Not Cleared Up .....                         | 66        |
| Replacing Consumable Parts .....  | 68        |
| Replacing the Wiper .....   | 68        |
| Replacing the Felt Wiper .....  | 71        |
| Replacing the Blade .....   | 74        |
| Replacing the Separating Knife .....  | 76        |
| When Not in Use for a Prolonged Period .....  | 78        |
| Keep Performing Maintenance .....   | 78        |
| Alarm Feature .....   | 78        |
| When Not in Use for a Prolonged Period, Precaution 1 .....                          | 78        |
| When Not in Use for a Prolonged Period, Precaution 2 .....                          | 78        |
| Special Maintenance .....   | 80        |
| Draining Ink and Performing Internal Washing .....                                  | 80        |
| Draining Ink Remaining Inside the Machine .....                                     | 80        |
| <b>Chapter 4 Part of Practice .....</b>   | <b>81</b> |
| Fully Utilizing Preset Function .....   | 82        |
| Saving Various Settings as a Name Assigned Preset .....                             | 82        |
| Loading a Saved Preset .....  | 83        |
| Automatic loading of a saved preset when media is loaded .....                      | 84        |
| Fully Utilize the Media Heating System .....  | 85        |
| What Is the Media Heating System? .....   | 85        |
| Making the Temperature Setting for the Media Heating System .....                   | 86        |
| Control of Media Heating System during Preheating .....                             | 88        |
| Drying the Trailing Edge of the Printing Area on the Dryer .....                    | 88        |
| Setting the Drying Time after Printing .....  | 89        |
| Using an Optional Dryer .....   | 90        |
| Using a Blower-fan Unit .....   | 90        |
| Fully Utilizing the Correction Function .....                                       | 91        |
| Correcting for Misalignment in Bidirectional Printing .....                         | 91        |
| Correcting for Misalignment in Bidirectional Printing More Precisely .....          | 92        |
| Alleviating Horizontal Bands and the Like (feed correction function) .....          | 92        |
| Accommodating to the Types and Condition of Media .....                             | 94        |
| Adjusting Head Height to Match Media Thickness .....                                | 94        |
| Using Transparent Media .....   | 95        |
| Printing Hard-to-dry Media .....  | 95        |
| Using the Media Easy to be Winkled/Hard to be Fed .....                             | 96        |
| Speeding Up Output for Narrow Media .....   | 97        |
| Preventing Soiling of the Media and Dot Drop-out .....                              | 98        |
| Using Sticky Media .....  | 99        |
| Fully Utilizing Cutting Function .....  | 100       |
| Hints and Tips for Cutting Setting .....  | 100       |
| Preventing Pulling of the Media with Undue Force When Performing Cutting Only ..... | 100       |
| Fine-tuning the Cutting Conditions .....  | 101       |
| Accurately Adjusting the Cutting-in Amount .....                                    | 103       |

|  |            |
|--|------------|
| Performing Distance Correction During Cutting.....   | 104        |
| Correcting Misalignment of the Printing and Cutting Positions.....                                     | 105        |
| Prioritize The Cuttings Settings of This Machine to The Settings of a Computer Side in Software RIP .. | 107        |
| Viewing the Automatic Environment Correction Function Settings .....                                   | 108        |
| Performing Printing and Cutting Separately.....  | 109        |
| To Perform Printing and Cutting Separately.....  | 109        |
| Printing with Crop Marks.....  | 109        |
| Aligning Automatically and Cutting.....  | 111        |
| Aligning Manually and Cutting .....  | 113        |
| Correcting Misalignment for Printing and Cutting Position When Using Crop Marks.....                   | 114        |
| Using Media Take-up System.....  | 117        |
| Features of the Take-up System .....   | 117        |
| What to Select at the Time of Media Setup.....   | 117        |
| Operating Conditions for the Take-up System .....  | 117        |
| About the Paper Tube.....  | 118        |
| How to Take Up Media.....  | 118        |
| How to Remove Taken-up Media.....  | 123        |
| <b>Chapter 5 To Administrators.....</b>  | <b>124</b> |
| Output Operation Management.....   | 125        |
| Printing a System Report.....  | 125        |
| Determining What Happens When Ink Runs Out .....   | 125        |
| Displaying the Amount of Media Remaining.....  | 126        |
| Making Sure to Verify the Setting for the Amount Remaining Every Time the Media Is Changed..           | 127        |
| Printing the Amount of Remaining Media.....  | 128        |
| System Management of Printer.....  | 129        |
| Setting for the Menu Language and the Units of Measurement.....  | 129        |
| Setting the Interval until Activation of the Sleep Mode (Power Saving Function).....                   | 129        |
| Viewing Information about the System of This Machine.....  | 130        |
| Returning All Settings to Their Initial Values.....  | 131        |
| Changing ink type (ECO-SOL MAX 2) .....  | 132        |
| About change of ink type.....  | 132        |
| How to change the ink type .....   | 132        |
| <b>Chapter 6 Read This Chapter Whenever You Face a Problem. (FAQ) .....</b>                            | <b>138</b> |
| Printer Does Not Start Up! .....   | 139        |
| The Printer Unit Doesn't Run.....  | 139        |
| The Media Take-up System Doesn't Run.....  | 140        |
| The Media Heating System Doesn't Warm Up .....   | 141        |
| Cannot cut off the media.....  | 141        |
| Cannot select "EDGE" and "PIECE".....  | 141        |
| Attractive Printing or Cutting is Impossible... ..   | 142        |
| Printed Results Are Coarse or Contain Horizontal Stripes .....   | 142        |
| Colors Are Unstable or Uneven .....  | 143        |
| The Media Becomes Soiled When Printed.....   | 144        |
| Cutting Is Misaligned or Skewed .....  | 145        |
| Media Jam Occurs! .....  | 146        |
| The Media Jams.....  | 146        |
| Media Feed is Not Smooth.....  | 147        |

|   |            |
|---|------------|
| Media Wrinkles or Shrinks .....                             | 147        |
| Media Feed Is Not Straight.....                             | 148        |
| Media Feed Is Not Smooth.....                               | 148        |
| The Media Cannot Be Taken Up Smoothly .....                 | 149        |
| The Media Cannot Be Taken Up Smoothly.....                  | 149        |
| Print Heads Stop Moving. Why? .....                         | 150        |
| What to Do First .....                                      | 150        |
| If the Print Heads Still Do Not Move .....                  | 150        |
| A Message Appears .....                                     | 152        |
| An Error Message Appears .....                              | 154        |
| <b>Chapter 7 Main Specifications.....</b>                   | <b>158</b> |
| Printing / Cutting Area .....                               | 159        |
| Maximum Area.....   | 159        |
| Maximum Area When Using Crop Marks.....                     | 159        |
| The Media-cutoff Location During Continuous Printing .....  | 160        |
| About the Blade.....  | 161        |
| Locations of the Power Rating and Serial Number Labels..... | 162        |
| Specifications .....  | 163        |

Company names and product names are trademarks or registered trademarks of their respective holders.

# Chapter 1

## Machine Highlights

---

|                                 |    |
|---------------------------------|----|
| Part Names and Functions .....  | 6  |
| Printer Unit.....               | 6  |
| Operation Panel.....            | 8  |
| Media Take-up System.....       | 9  |
| Menu List .....                 | 10 |
| Main Menu.....                  | 10 |
| Language and Unit Menu .....    | 13 |
| Cleaning Menu .....             | 14 |
| Heater Configuration Menu ..... | 14 |
| Cutting Configuration Menu..... | 14 |

# Part Names and Functions

## Printer Unit

### Front

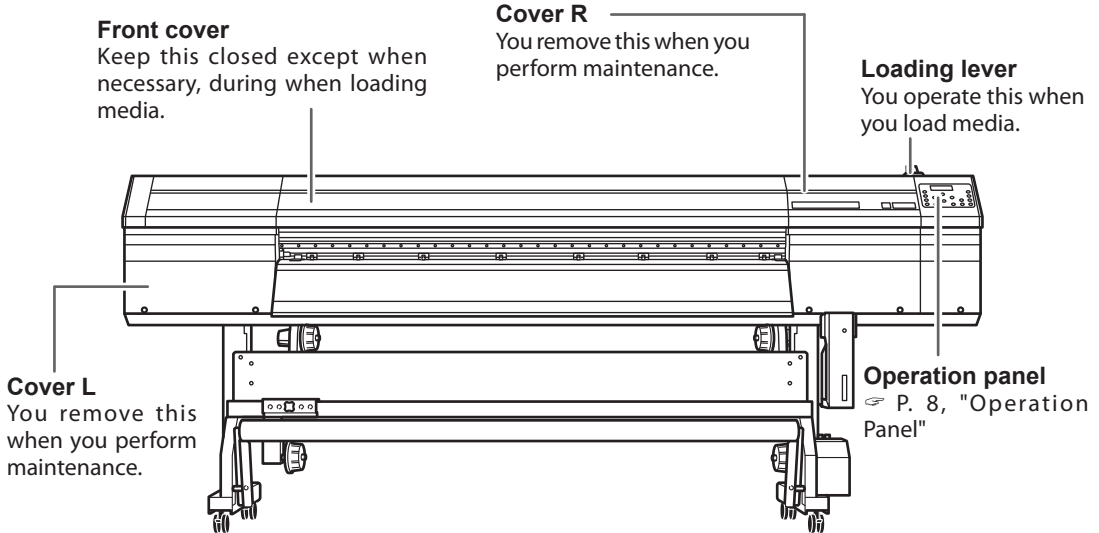

### Rear

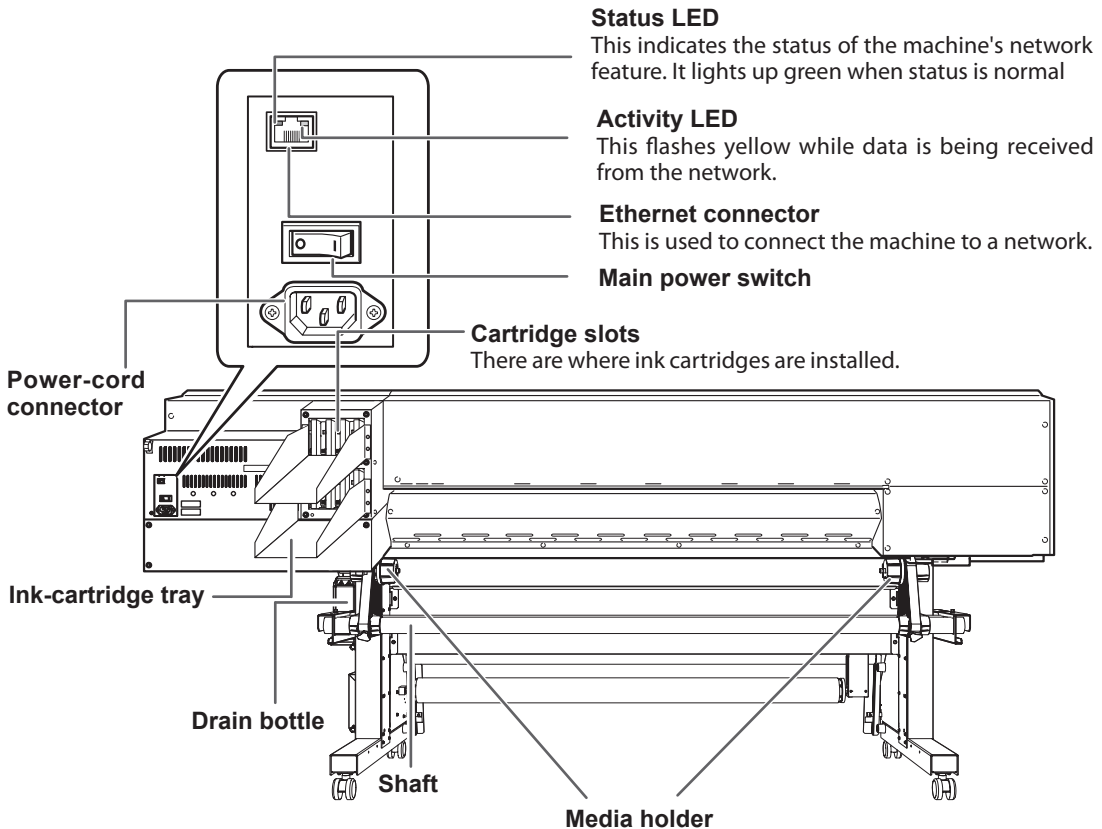



Front cover inside/print head periphery

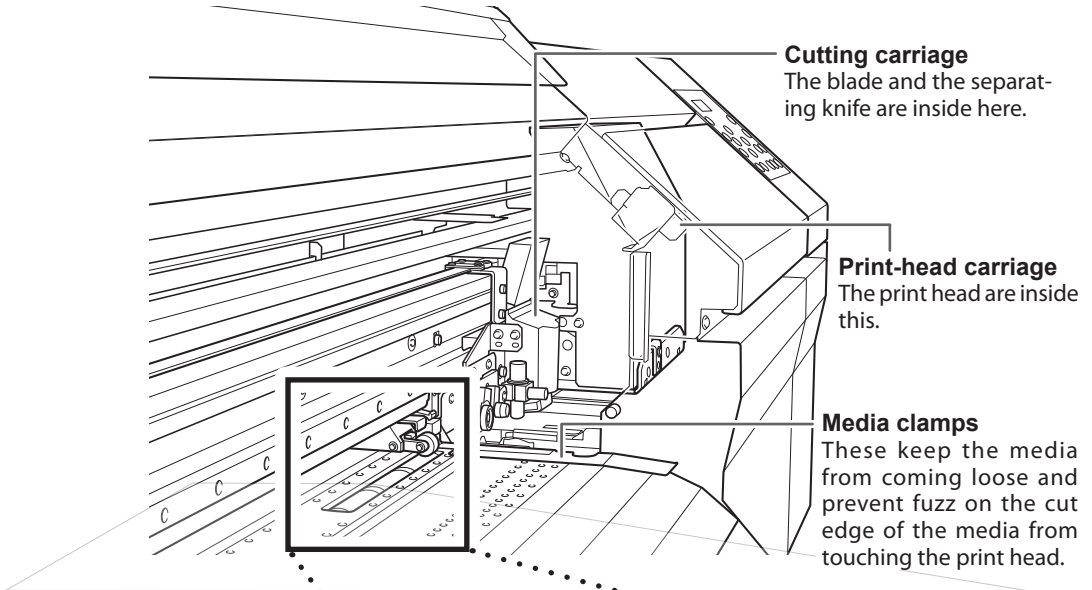

**Pinch rollers**  
These clamp the media when the loading lever is pulled back toward you.

**Grit rollers**  
These rollers feed out media toward the front of the machine.

**Knife guide**  
The separating knife passes through this when you perform media cutoff.

**Blade protector**  
This protects the tip of the blade during cutting.

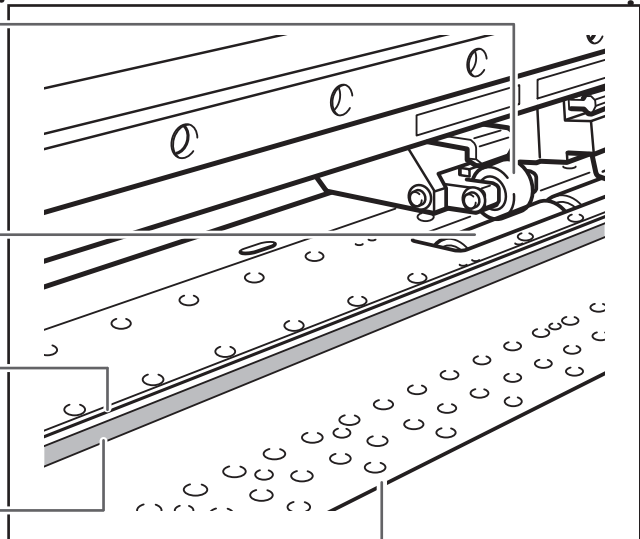

**Platen**  
This is the path over which the media passes. A suction fan that keeps the media from coming loose and print heater that helps fix the ink are built in.

## Operation Panel

### Display screen

This displays various setting menus and other information.

### TEST PRINT key

Holding this down for one second or longer performs a printing test.

### CLEANING key

You use this to perform cleaning of the print heads.

### TEST CUT key

TEST CUT key Holding this down for one second or longer performs a cutting test.

### CUT CONFIG key

This displays the menu for setting the conditions for cutting.

### MENU key

You press this to enter the menus for various settings.

### Cursor keys

You use these to select settings for menu items, to move the media, and for other such operations.

### BUSY light

This lights up during printing, cutting and other such operations.

### BASE POINT key

You use this when you want to set the outputstart location. This lights up when the setting has been made.

### SETUP key

You press this when you load media. This lights up when media is loaded and the machine is ready to perform output.

### PAUSE key

This pauses printing operation. This lights up when operation is paused.

### SHEET CUT key

Holding this down for one second or longer cuts off media.





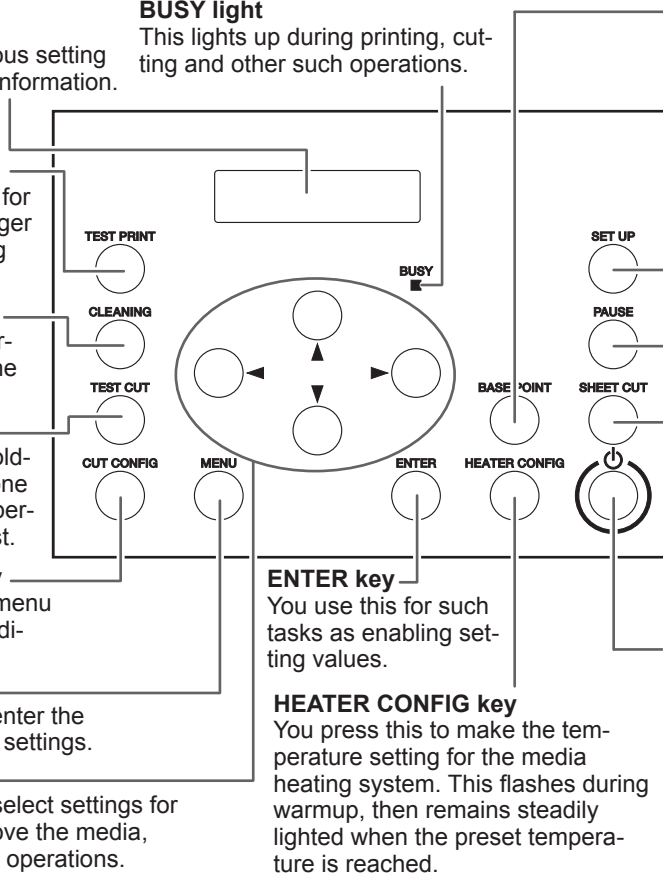







### Sub power switch

This switches the printer on and off. (To switch the printer off, you hold down the switch for one second or longer). The light flashes slowly when the machine is in the sleep mode.



## Panel Notation

In this document, the keys on the operation panel are indicated by the following illustration.

-  **MENU key**
-  **SETUP key**
-  **ENTER key**
-  **Cursor keys**
-  **PAUSE key**
-  **CLEANING key**
-  **TEST PRINT key**
-  **TEST CUT key**
-  **BASE POINT key**
-  **CUT CONFIG key**
-  **HEATER CONFIG key**
-  **SHEET CUT key**

# Media Take-up System

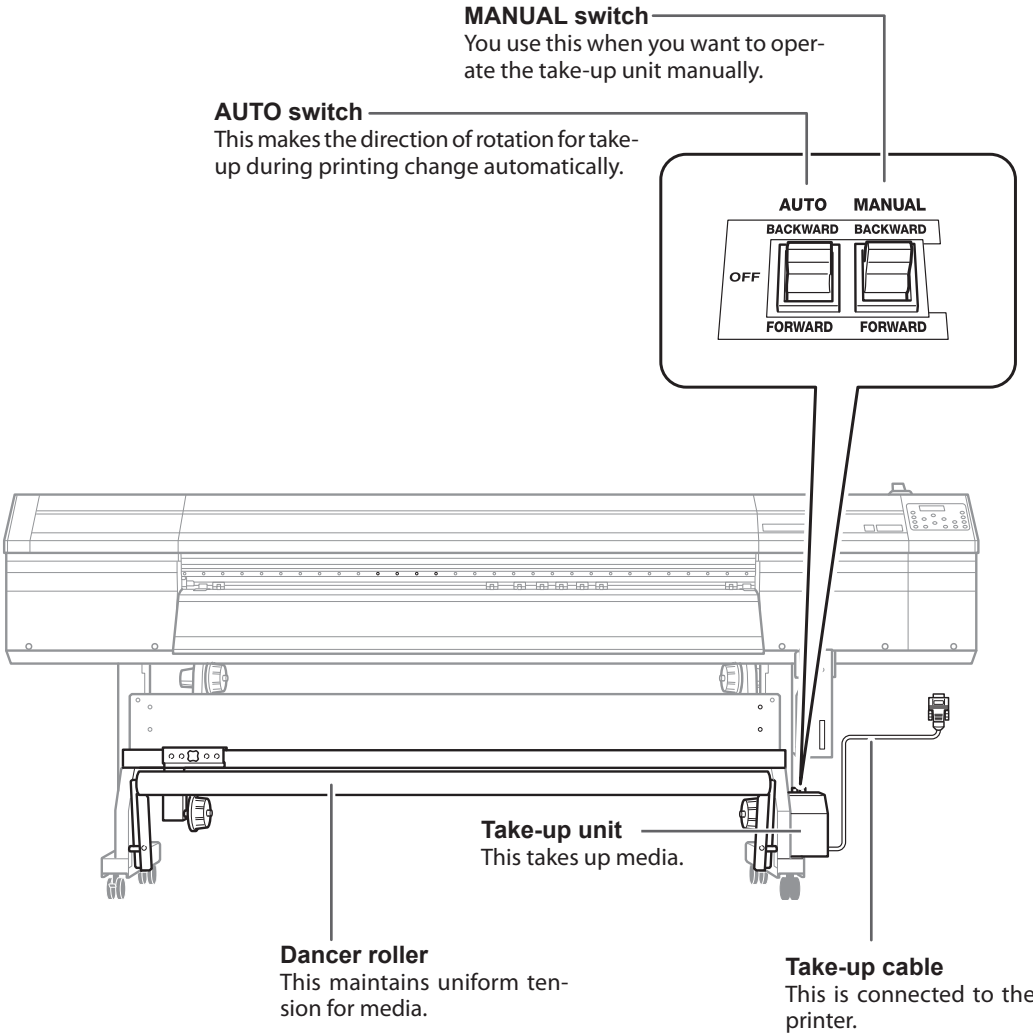

# Menu List

## Main Menu

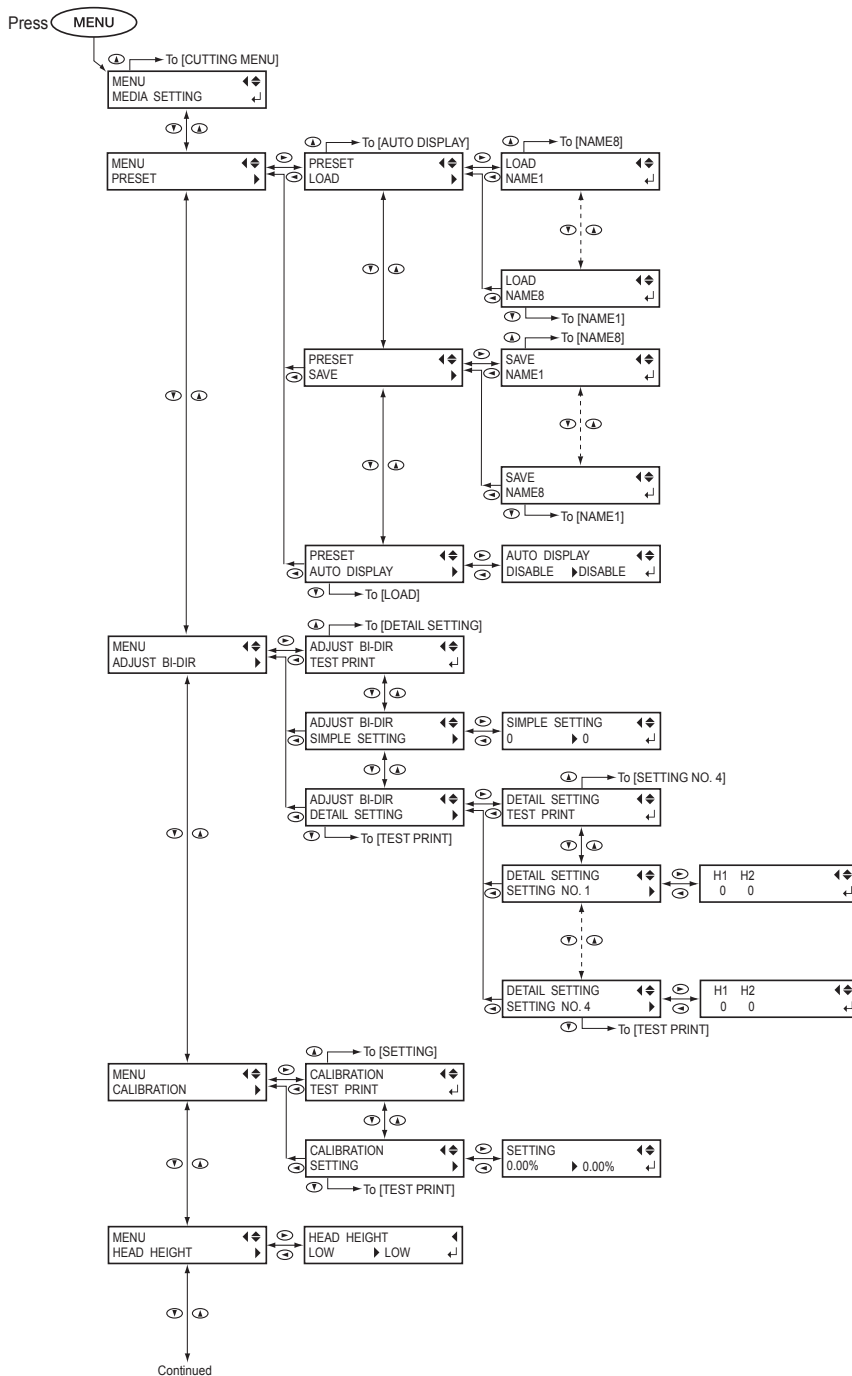

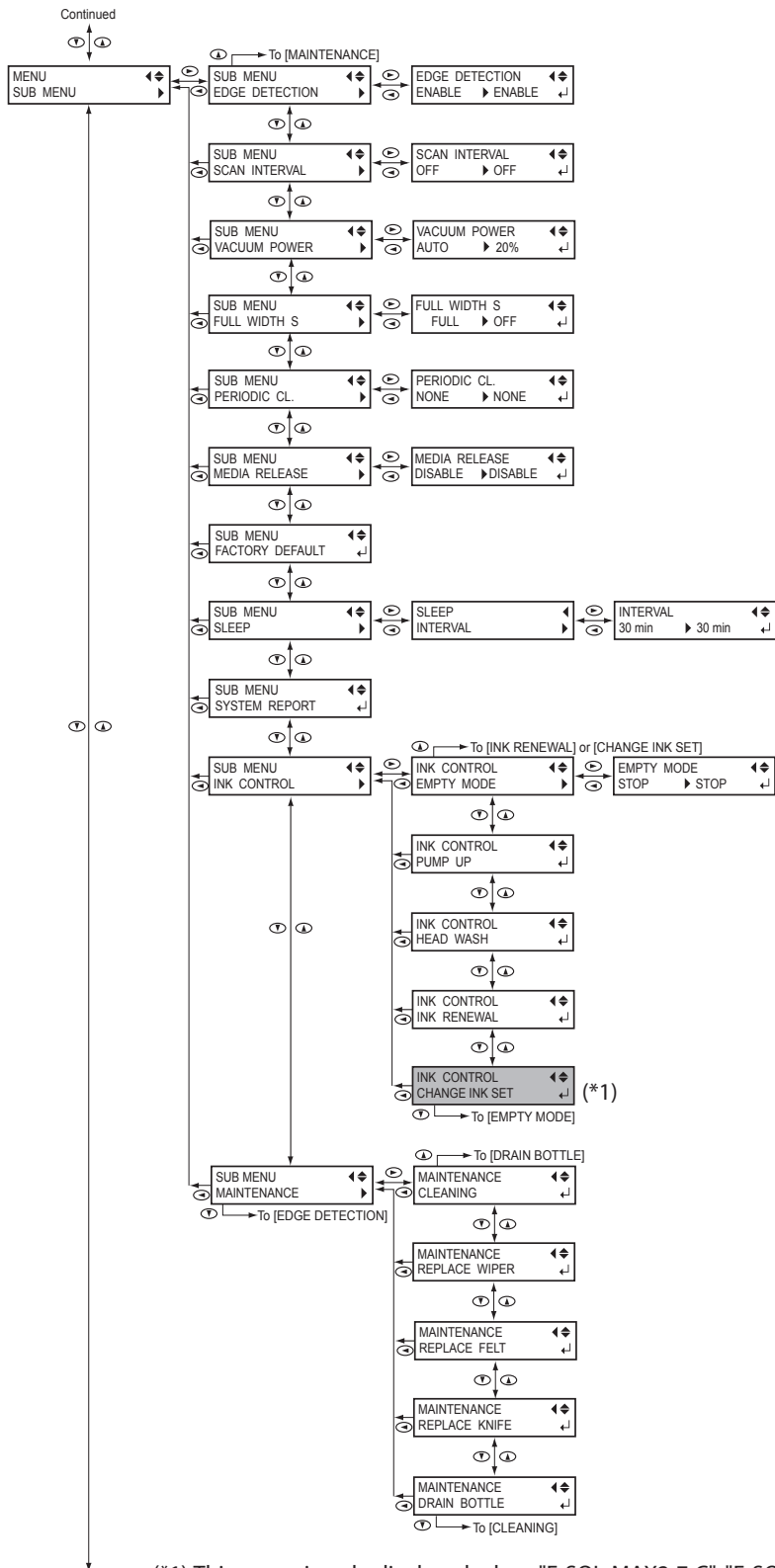

(\*1) This menu is only displayed when "E-SOL MAX2 7 C", "E-SOL MAX2 LkW", "E-SOL MAX2 LkMT", or "E-SOL MAX2 WMT" is selected for the ink type.

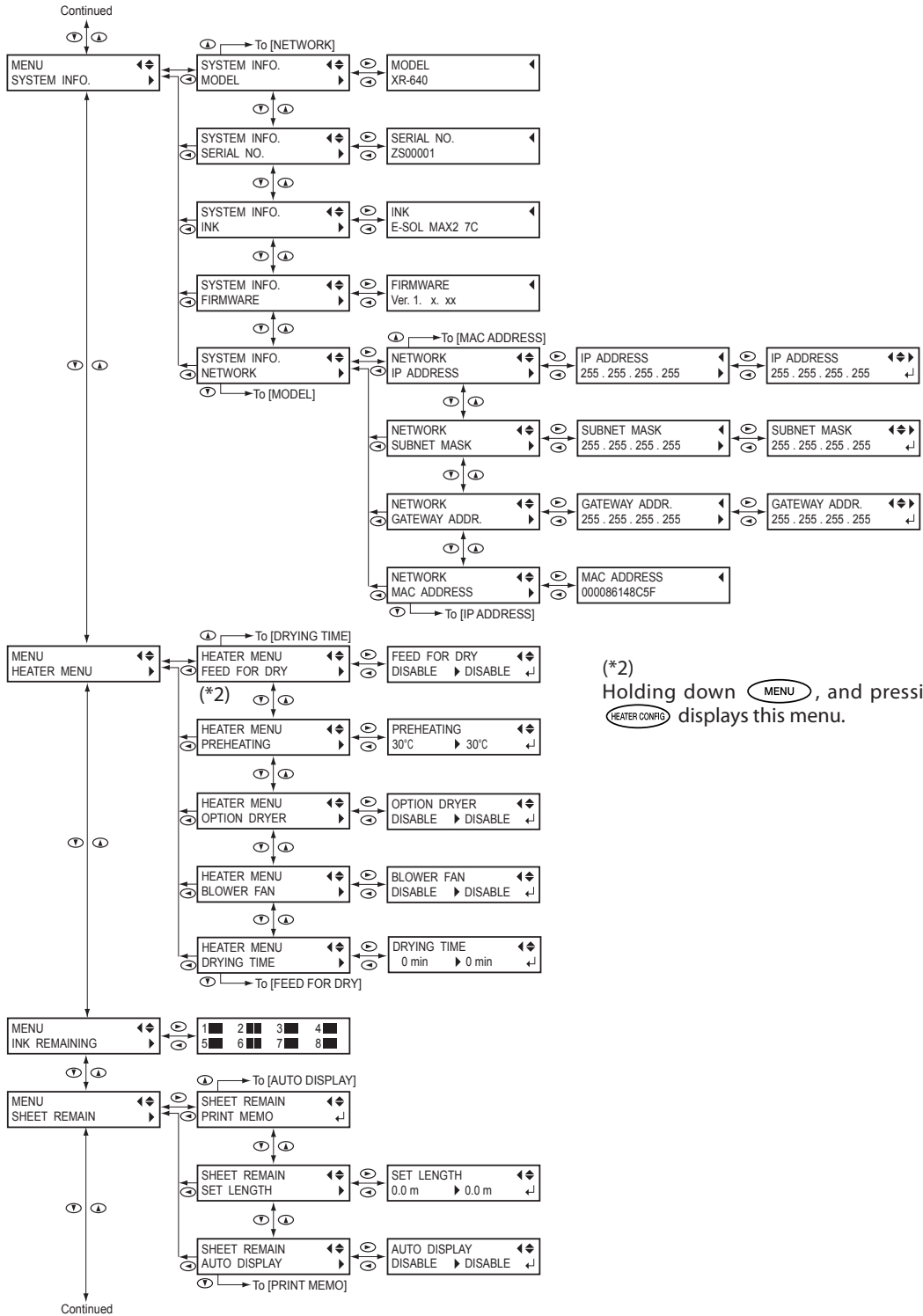

(\*2)  
Holding down **MENU**, and pressing **HEATER CONFIG** displays this menu.

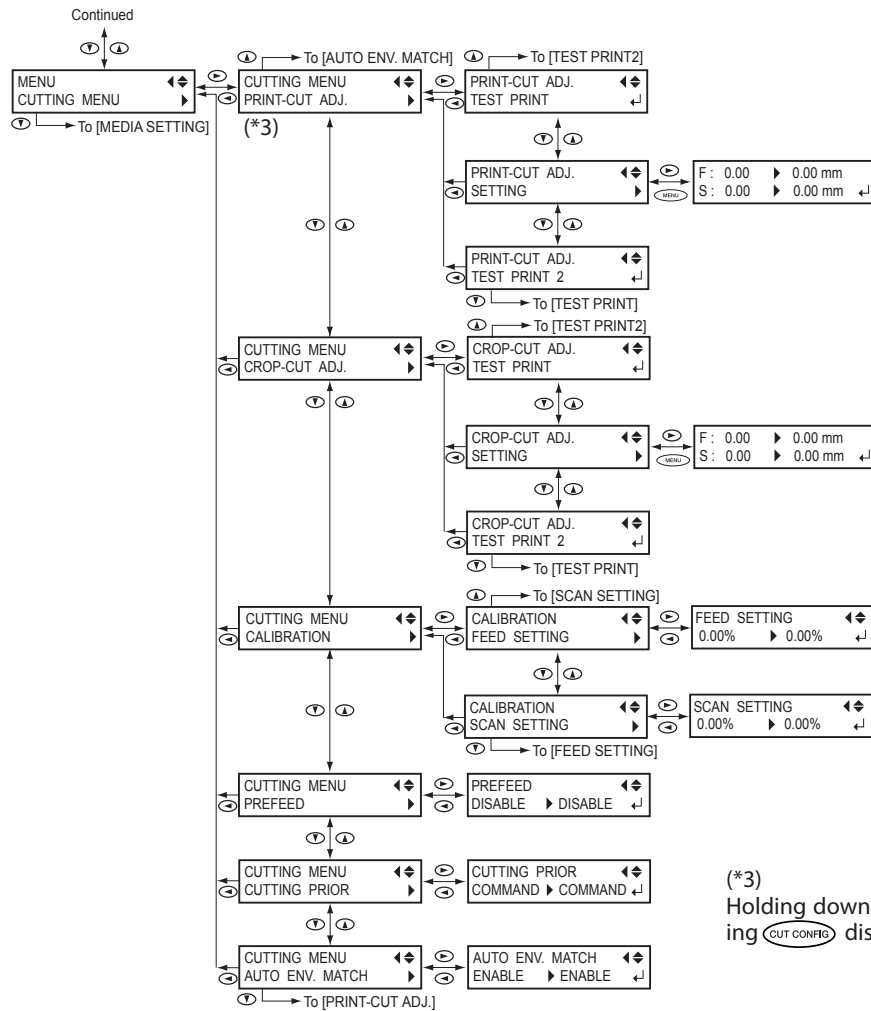

## Language and Unit Menu

Hold down **MENU** and switch on the sub power.

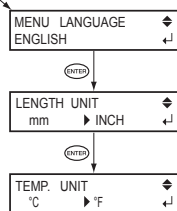

## Cleaning Menu

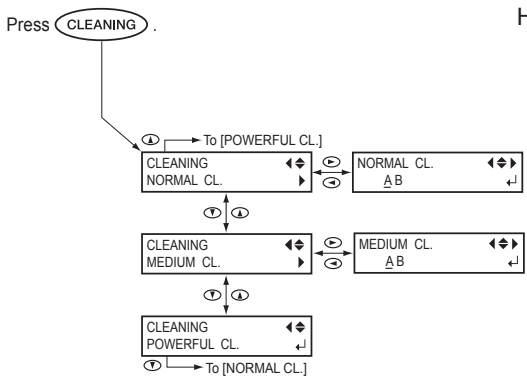

Hold down **CLEANING** for one second or longer.

Head cleaning for all groups

☞ P. 44, "When you want to clean all heads simultaneously"

## Heater Configuration Menu

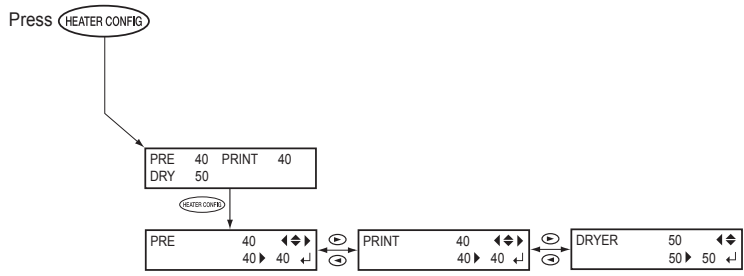

## Cutting Configuration Menu

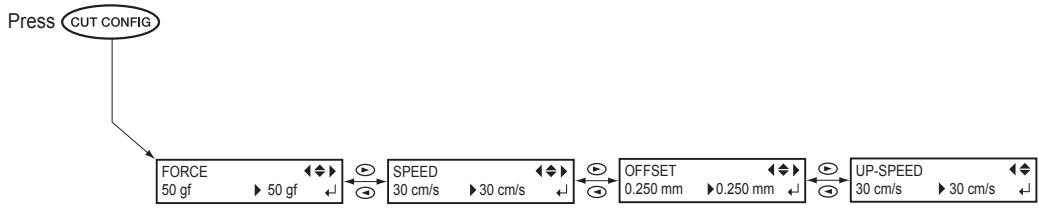



# Chapter 2

## Basic Operation

---

|   |    |
|---|----|
| Prepare the Media .....   | 16 |
| Type of Media .....   | 16 |
| Usable Media.....   | 17 |
| Switch On!.....   | 18 |
| Switch On! .....  | 18 |
| The Power-saving Feature (Sleep Mode).....  | 18 |
| Loading Media .....   | 19 |
| Loading Roll Media.....   | 19 |
| Loading the Sheet Media.....  | 27 |
| Performing the Initial Adjustment (Correcting for Misalignment in Bidirectional Printing More Precisely)..... | 29 |
| Setup of Media.....   | 31 |
| About [Media Setting] menu .....  | 31 |
| Setup of Media ([Media Setting] menu).....  | 31 |
| Outputting .....  | 42 |
| Setting the Output-start Location.....  | 42 |
| Printing Tests and Normal Cleaning .....  | 43 |
| Important Note on Cutting .....   | 45 |
| Setting The Cutting Test And The Blade Force.....   | 46 |
| Getting Ready to Receive Data from a Computer .....   | 47 |
| Starting Output .....   | 48 |
| Pausing and Canceling Output.....   | 49 |
| Cutting Off the Media.....  | 49 |
| Switch Off.....   | 51 |
| Switch Off .....  | 51 |

# Prepare the Media

## Type of Media

In this manual, the paper used for output is called "media." There are the following main two media types used in this machine.

- **Roll media: Media wound onto a paper tube**
- **Sheet media: Media not wound onto a paper tube such as standard-size media**

Various paper quality types of roll media and sheet media are selectable according your purpose. For detailed information about each media, contact your media supplier. Media is also available from our following website.  
<http://www.rolanddg.com/>

## Usable Media

This machine cannot necessarily print every kind of media. When selecting media, be sure to carry out testing in advance to make sure that satisfactory printing quality is obtained.

---

### Size

---

#### Width (For both Roll Media and sheet media)

315 to 1625 mm (12.4 to 64 inches)

#### A) Cuttable media thickness (For both Roll Media and sheet media)

0.08 mm to 0.22 mm (0.3 to 1 mil) (depending on media composition)

#### B) Maximum media thickness (For both Roll Media and sheet media)

Printing only: 1.0 mm (4mil)

When performing cutting: 0.4 mm (1.6 mil)

#### Roll outer diameter

210 mm (8.2 inches)

#### Paper tube (core) inner diameter

76.2 mm (3 inches) or 50.8 mm (2inches)

---

### Roll weight

---

40 kg (88 lb.)

---

### Other conditions

---

Media such as the following cannot be used.

- Media whose end is attached to the paper tube (core)
- Media which is severely warped or which has a strong tendency to reroll
- Media that cannot withstand the heat of the media heating system
- Media whose paper tube (core) is bent or crushed
- Media that bends under its own weight when loaded
- Media on a sagging roll
- Media that is rolled unevenly

# Switch On!

## Switch On!

### ⚠ WARNING

When output is not being performed, remove any loaded media or switch off the sub power.

The continued application of heat at a single location may cause the release of toxic gases from the media or pose a fire hazard.

### Procedure

1

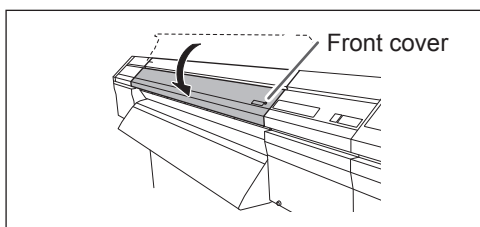

Close the front cover.

2

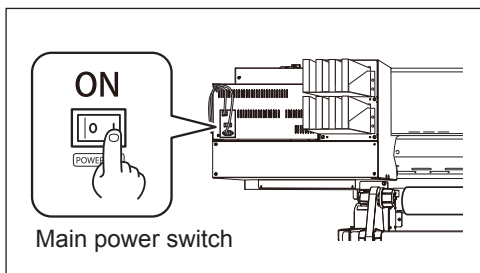

Turn on the main power switch.

3

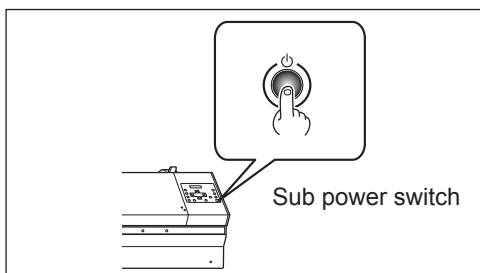

Press the sub power button.

**Note:** For installation of the ink cartridge and selection of the language displayed on the display screen, refer to Setup Guide.

## The Power-saving Feature (Sleep Mode)

This machine is provided with a power-saving feature that switches to a low-power "sleep mode" when a fixed interval passes with no operation. The factory default for the time after which the machine switches to the sleep mode is 30 minutes. When the machine is in the sleep mode, the sub power switch flashes slowly. Using the operation panel or performing operations such as sending output data from the computer (when media is loaded) restores the machine to its normal mode.

This setting of sleep mode can be changed. However, we recommend setting the activation time for the sleep mode to 30 minutes or less to reduce power consumption and prevent problems such as overheating.

☞ P. 129, "Setting the Interval until Activation of the Sleep Mode (Power Saving Function)"

# Loading Media

## Loading Roll Media



**Load roll media correctly.**  
Otherwise the media may fall and cause injury.



**Roll media weighs about 40 kg (88 lb.). To avoid injury, handle with care.**



**Never load media that weighs over 40 kg (88lb.).**  
The machine may fail to withstand the weight and tip over or cause the media to fall.

### 1. Install the media to the media holder.

1

- 1 Open the front cover.
- 2 Move the media clamps to the left and right ends respectively.

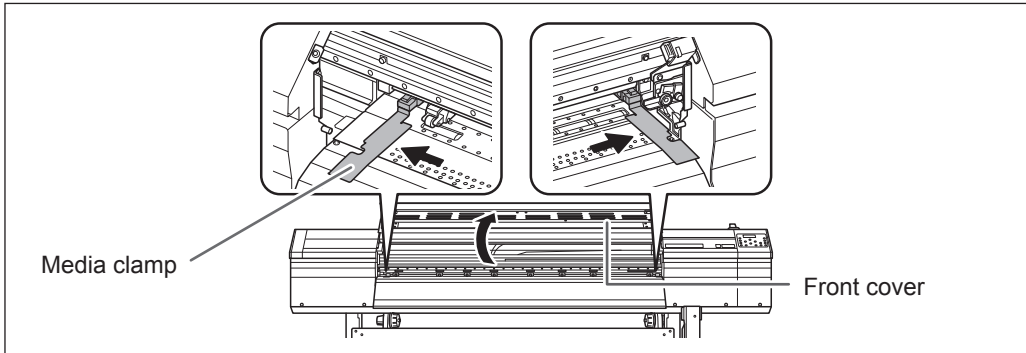

2

- 1 Loosen the retaining screws of the media holders.
- 2 Move the media holders all the way to the left and right.

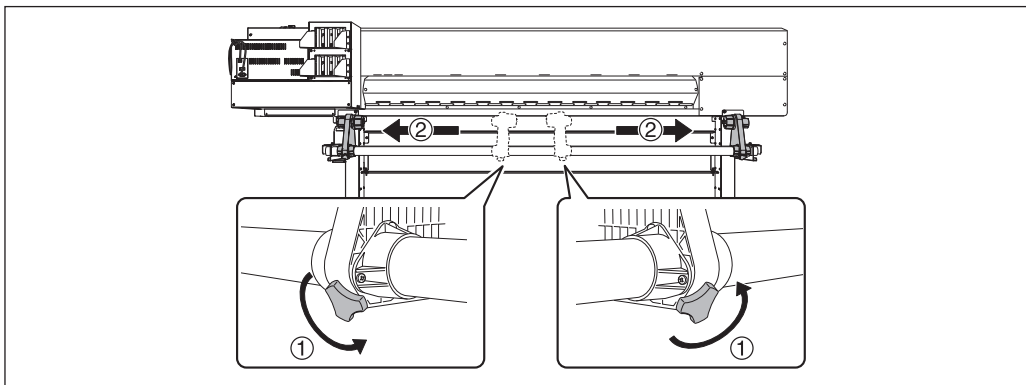

- 3 ① **Fit the paper tube (core) onto the end cap of the media holder [Left].**  
Do not secure the media holder now.
- ② **Move the media holder [Right] and fit the end cap onto the paper tube core of the media.**  
Fit it securely to prevent the media from easy loose.

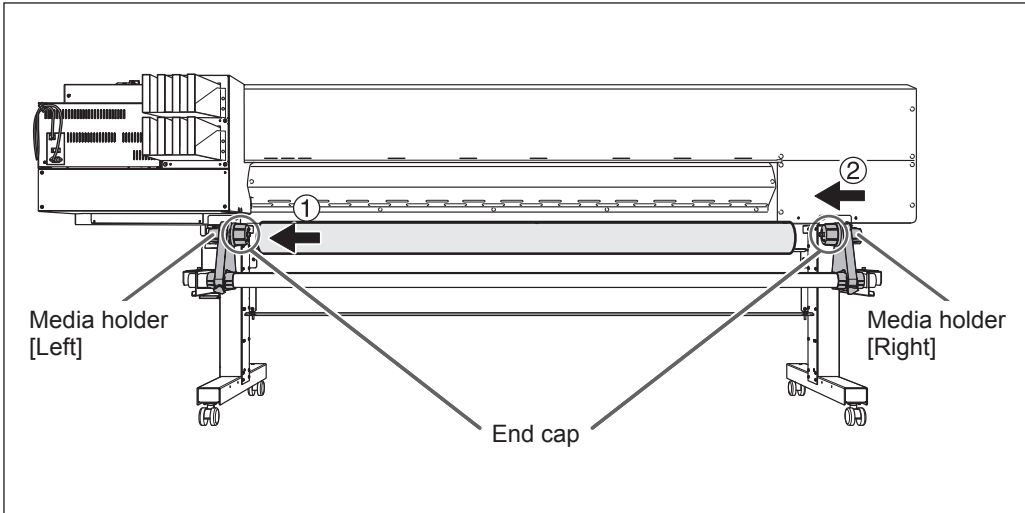

**IMPORTANT!** Install conforming to the procedures.  
Load the media while the left media holder is positioned close to the left edge, as shown in the figure. Also, never secure the media holder in place before loading the media. Loading media without performing these steps in the proper order may make smooth media feed impossible or yield poor printing results.

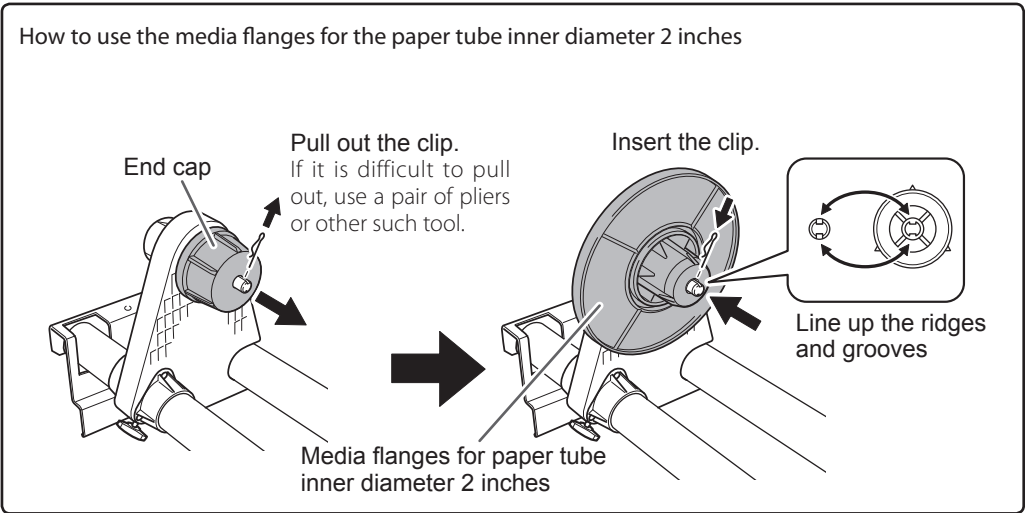

- 4 **Hold the outer side of the media holder [Left] and position the left and right side edges of the media to match the grit patterns.**

When deciding the position, hold the both sides of media holders from the outer sides and move it. Do not hold the media directly to move.

**CAUTION**

**Never attempt this operation while holding any location other than the one specified.**

The media may fall from the media holder, resulting in injury.

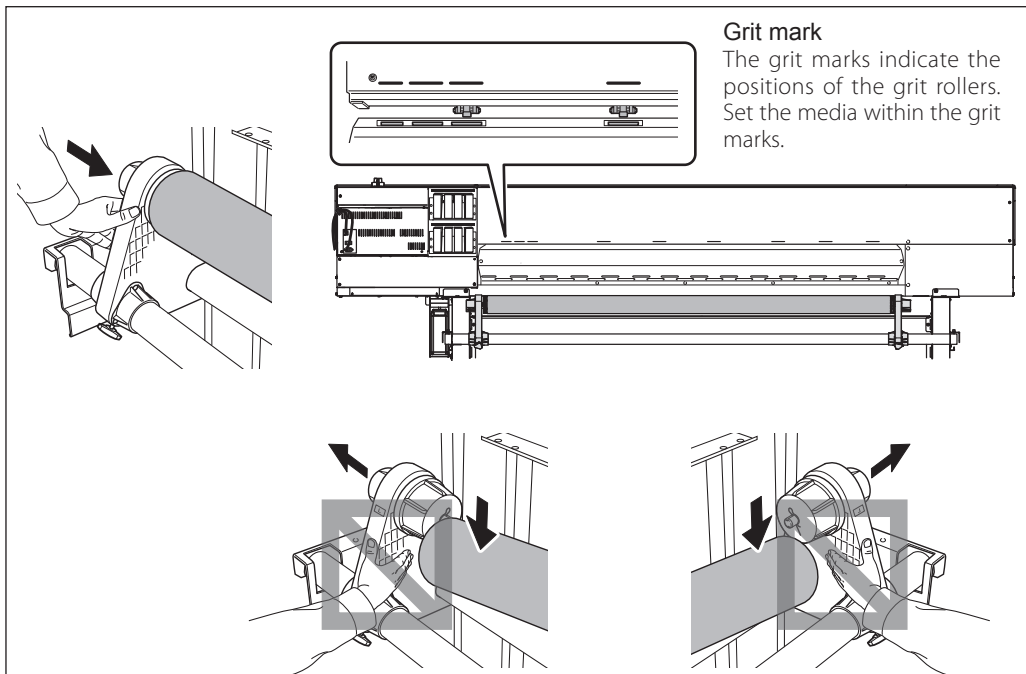

**IMPORTANT!** Decide the left and right side positions of the media finally at this step.

After this procedure is completed, if the left and right side positions do not fit the proper position when securing the media with pinch rollers, go back to this step to redo this procedure. Printing quality is affected due to skew media feed, if you hold the media only to readjust the position forcibly.

- 5 **Secure the media holder by tightening the securing screws slightly.**

The retaining screw may get damaged if tightened excessively.

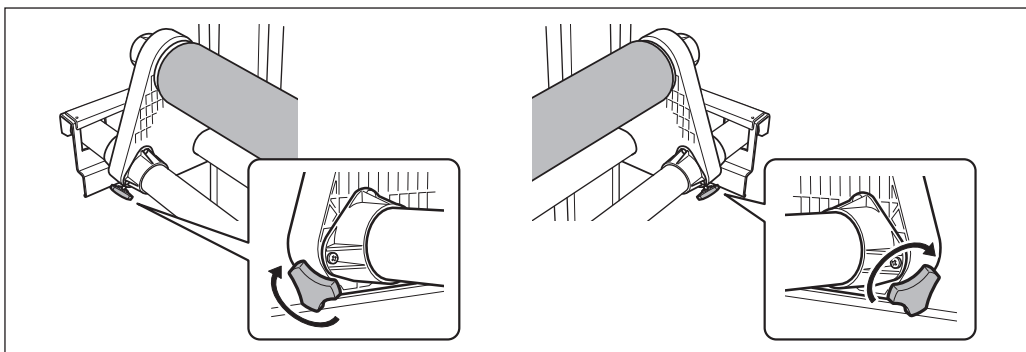

## 2. Pass the media through the printer and secure the media holders.

- 1 Pass the leading edge of the media between the pinch rollers and the grit rollers.

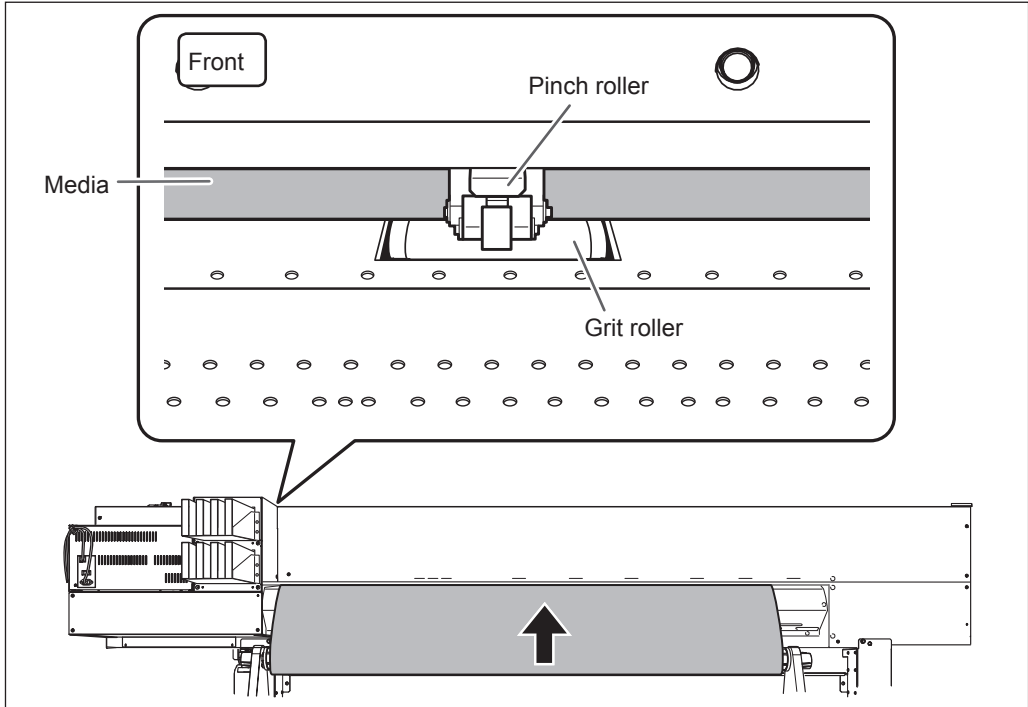

- 2 Pull out the media over the platen.

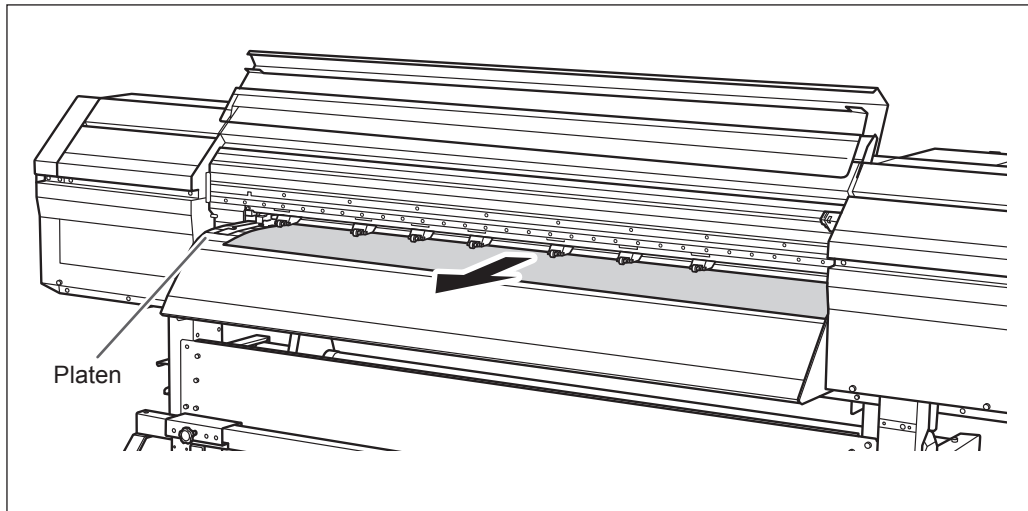



**3 Check both edges of the media are placed on the grit rollers.**

Be sure to place the right edge of the media on the right end grit rollers.

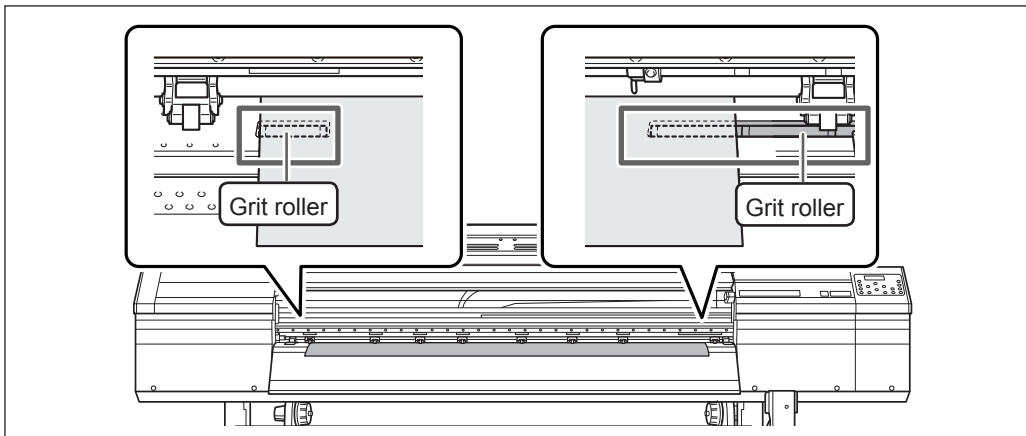

**4 Place the left and right pinch rollers on both edges of the media.**

Place them on the positions from the media edges by about 10 mm respectively.

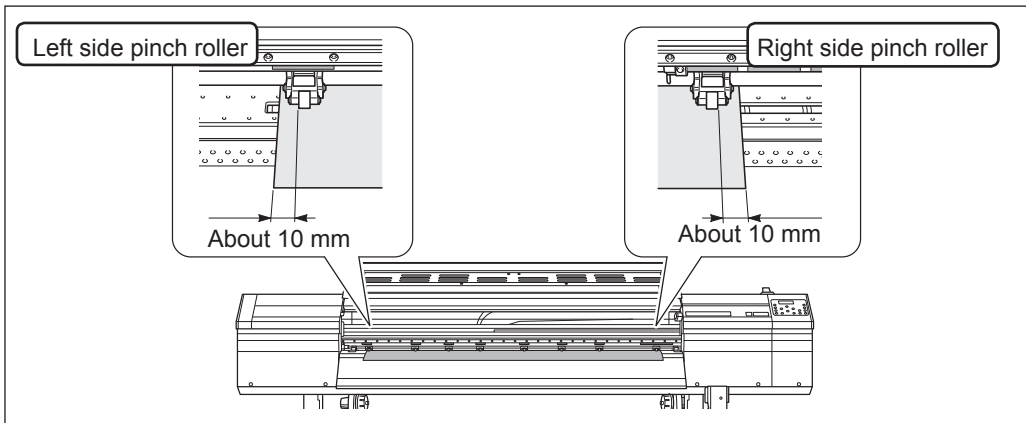

**IMPORTANT!**

If you want to readjust the media position at this step, go back to the procedure 1 and redo the procedure 1 - 4. Printing quality is affected due to skew media feed, if you hold the media only to readjust the position forcibly.

5 Place the middle pinch rollers.

**POINT!**

For the middle pinch rollers, choose positions that are as evenly spaced as possible with respect to the width of the media. The middle pinch rollers, however, cannot be lowered at any position other than above the grit rollers. You can vary the number of middle pinch rollers used according to the width and composition of the media. Increasing the number used makes media feed correspondingly more stable.

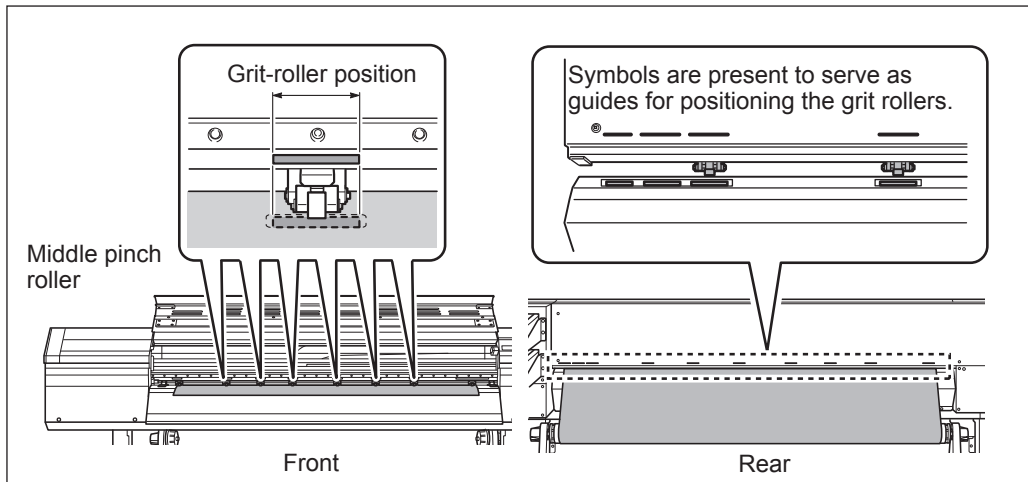

6 Hold the media at the center and pull it out, being sure to keep it straight and all areas of the media to be taut.

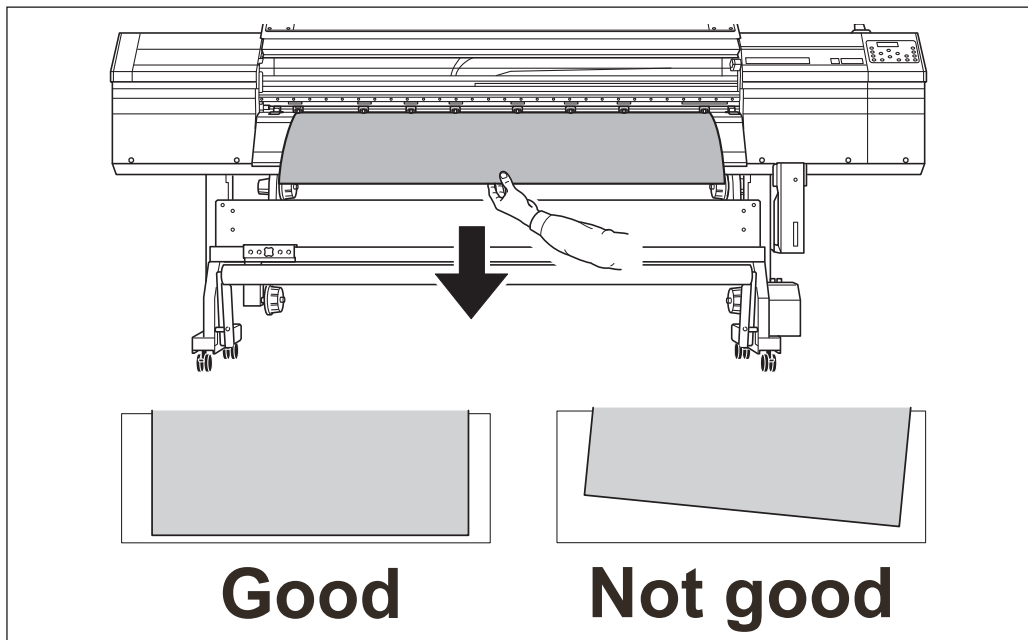

7

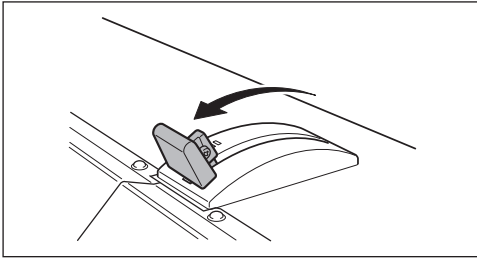

Pull the loading lever back toward you to secure the media in place.

### 3. Clamp the edges of the media with the media clamp.

1

① Move the left and right media clamps above the edges of the media.

② Line up the edges of the media with the centers of the holes of the media clamps.

When you're performing cutting only, never use the media clamps.

☞ P. 45, "Important Note on Cutting"

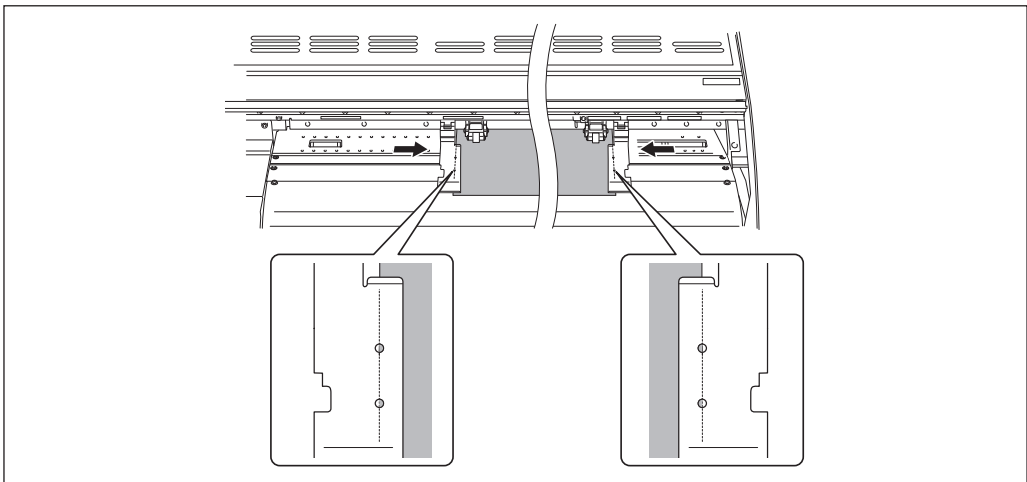

#### ***Important Note When Using the Media Clamps***

Insert the media clamps firmly all the way until they engage with an audible click, and make sure they will not come loose. Incorrect mounting may cause the media to catch or snag and make correct printing impossible, or may lead to malfunction or poor output quality.

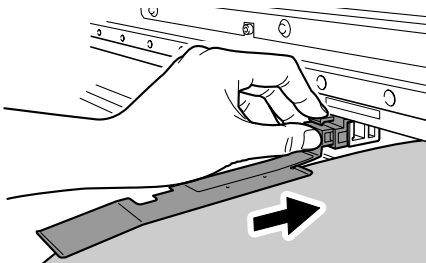

2 Close the front cover.

3  Press   to select "ROLL."  
Press .

4 Press .

The print-head carriage moves and detects the width of media. This operation is called initialization. When initialization ends,  remains steadily lighted, and the printable width is displayed on the display screen. This completes loading of the media.

**IMPORTANT!** Remove when not using roll media.

If roll media is allowed to stand unused in a loaded state for an extended period, the media may sag. This can cause poor printing quality and motor errors, so be sure to remove and store such media when not in use.

## Loading the Sheet Media

### Procedure

**1 Move the media holders to the left and right.**

Move them to a location where they don't disturb the media when the media is hung down from the rear of the machine. If they disturb the media, remove them with the shaft. For information on how to remove, refer to "Setup Guide."

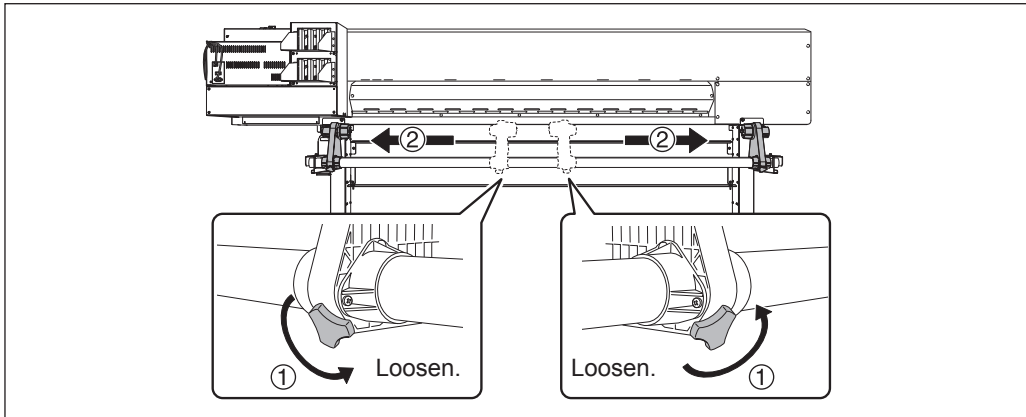

**2 Pass the media through the printer and secure the media holders.**

☞ P. 19, "Loading Roll Media" Procedure 2. 1 to 5 of [Loading Roll Media]

**3 Align the front edge of the media with the location shown in the figure.**

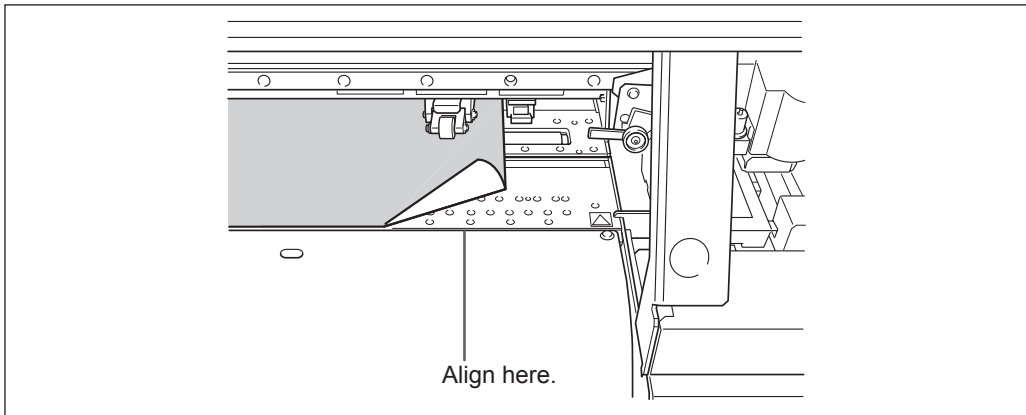

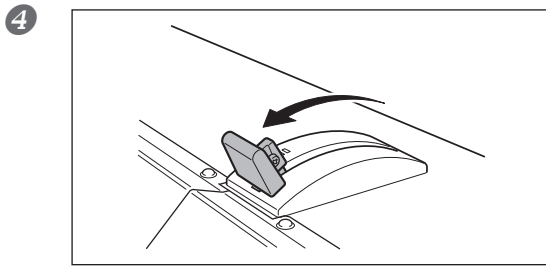

**4** Pull the loading lever back toward you to secure the media in place.

- 5** ① Move the left and right media clamps above the edges of the media.  
 ② Line up the edges of the media with the centers of the holes of the media clamps.  
 When you're performing cutting only, never use the media clamps.

☞ P. 45, "Important Note on Cutting"

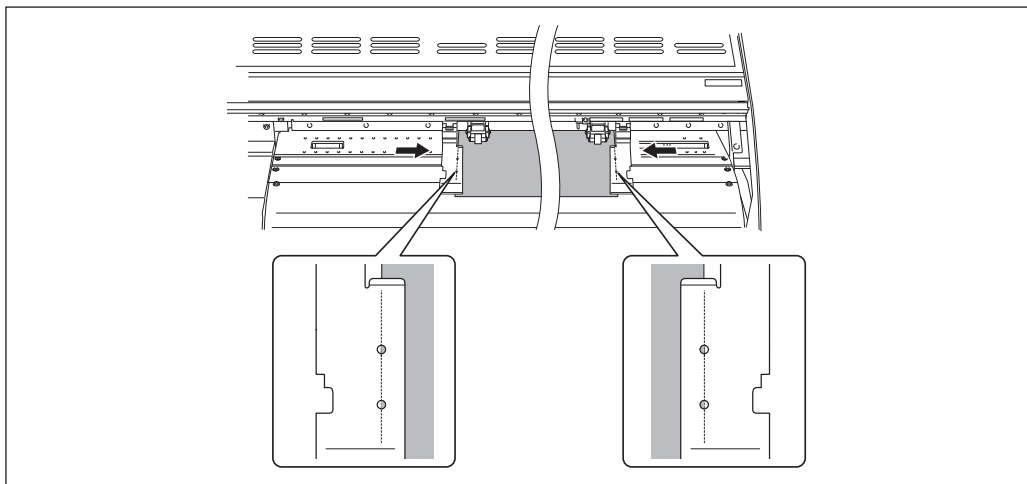

**Important Note When Using the Media Clamps**

Insert the media clamps firmly all the way until they engage with an audible click, and make sure they will not come loose. Incorrect mounting may cause the media to catch or snag and make correct printing impossible, or may lead to malfunction or poor output quality.

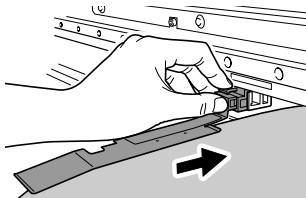

- 6** Close the front cover.

- 7**  Press   to select "PIECE."  
 Press .

- 8** Press .





The print-head carriage moves and detects the width of media. This operation is called initialization. When initialization ends,  remains steadily lighted, and the printable width is displayed on the display screen. This completes loading of the media.

## Performing the Initial Adjustment (Correcting for Misalignment in Bidirectional Printing More Precisely)

Perform the initial adjustment (correction for misalignment in bidirectional printing more precisely) of this machine. In the following case, perform this adjustment.

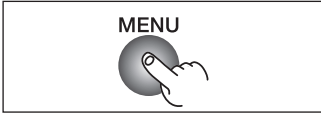
- When using this machine for the first time
- When changing the media to use for the first time
- When further correction is required to improve printing, such as when simple correction is performed for misalignment in bidirectional printing. (P. 91, "Correcting for Misalignment in Bidirectional Printing")

### 1. Print a test pattern.

- 1  Press **MENU**.
- 2  Press **▼** several times to display the screen shown on the left. Press **▶**, and then **▲**.
- 3  Press **▶**.
- 4  Press **ENTER**.  
A test pattern is printed.  
When printing ends, then press **▼**.

### 2. Read the correction values from the test pattern.

Choose the value that produces the least misalignment of 2lines.

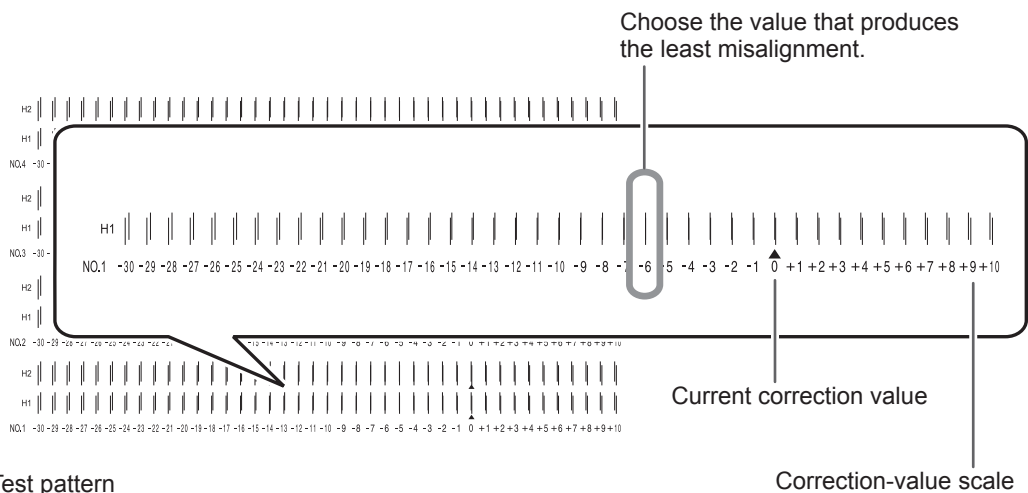

### 3. Enter the correction values that you read.

Enter the correction value for H1 and H2, respectively.





① 

|                |    |
|----------------|----|
| DETAIL SETTING | ◀▶ |
| SETTING NO. 1  | ▶  |

 Press .

② 

|    |    |    |
|----|----|----|
| H1 | H2 | ◀▶ |
| 0  | 0  | ↵  |

 Press   to select H1 or H2.  
Press   to select the correction value.  
Select the values that you read at the step 2. for correction values.  
When correction value settings end, press .

This completes [SETTING NO.1]. Keep pressing  and set the correction values for [SETTING NO.2] to [SETTING No.4] in the same manner.

③ Press   in this order to go back to the original screen.



## About [Media Setting] menu

To ensure the optimal output according to the media size and type, various setting items are provided in this machine. However, it is hard work to perform these settings one by one referring to this document. So, this machine provides the [Media Setting] menu that guides these settings in the interactive mode. Using this menu, you can set all of the basic settings only by setting according to the instructions on the display. Since the setting details can be stored as the preset menu, you can promote your operation efficiently saving the setup steps when using the same type of media. Once storing the basic settings as the preset, you can do fine adjustment according to need. The items set through the [Media Setting] menu can be also set individually.

## Setup of Media ([Media Setting] menu)

- Only Printing: Perform the procedure **1.** to **6.**, and **10.** to **11.**
- Printing & Cutting: Perform all the procedure **1.** to **11.**

Note: If any setting is not needed for each setting item, you can go to the next menu by selecting [NEXT].

### 1. Starting the [Media Setting] menu.

#### 1 Load media.

Check that no sagging is found on the media. If any sagging exists, the followed correction value settings do not work effectively.

☞ P. 19, "Loading Media"

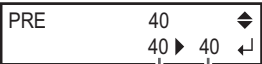
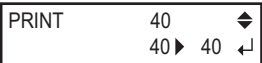

### 2. Set the temperature of preheater, print heater and dryer.

- 1
- 
- Use **▲** **▼** to set the temperature.  
Recommended temperature: 40 °C  
Press **ENTER** to enable the setting.
- 2
- 
- Use **▲** **▼** to set the temperature.  
Recommended temperature: 40 °C  
Press **ENTER** to enable the setting.

- 3 

|       |         |   |
|-------|---------|---|
| DRYER | 50      | ↕ |
|       | 50 ▶ 50 | ↵ |

**Use** **to set the temperature.**  
 Recommended temperature: 50 °C  
**Press** **to enable the setting.**

For the individual setting method of this setting item and the description, refer to P. 86, "Making the Temperature Setting for the Media Heating System"

**To cancel the setting**

**Procedure**

1 Press during the setting.

2 

|               |     |
|---------------|-----|
| QUIT SETTING? | ◀ ▶ |
| YES [NO]      | ↵   |

**Press** **to select [YES].**  
**Press** .

|               |     |
|---------------|-----|
| MENU          | ◀ ▶ |
| MEDIA SETTING | ↵   |

 The screen returns to the screen shown at the left.  
 By selecting [NO], the screen returns to the screen displayed when you pressed .

### 3. Adjusting the Head Height

- 1 

|               |     |
|---------------|-----|
| HEAD HGT LOW  | ◀ ▶ |
| [CHANGE] NEXT | ↵   |

**Press** **to select [CHANGE].**  
**Press** **to enable the setting.**

- 2 

|             |   |
|-------------|---|
| HEAD HEIGHT |   |
| LOW ▶ LOW   | ↵ |

**When the left figure is displayed, open the front cover.**

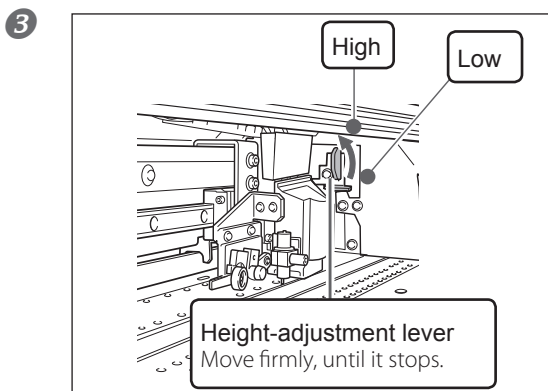

**Move the height-adjustment lever to adjust the head height.**

When moving to the [High] direction, the buzzer sounds twice, and to the [Low] direction, the buzzer sounds once.

**POINT!**

Normally set to [Low]. For the media that is wrinkled and comes loose from the platen, set to [High].

#### 4 Close the front cover.

For the individual setting method of this setting item and the description, refer to P. 94, "Adjusting Head Height to Match Media Thickness"

### 4. Perform the position correction of feed direction (Alleviate Horizontal Stripes).

#### POINT!

Feed direction means the feed direction of the media. Perform the correction adjusting to the media in advance because horizontal stripes are more likely to occur during printing when the movement distance of the media changes subtly depending on the media's thickness.

1

CALIBRATION  
[SET] NEXT

Press to select [SET].  
Press to enable the setting.

The test pattern of feed correction is output.

2

INPUT  
ADJ. VALUES

When the left figure is displayed, press .

3

CALIBRATION  
0.10% ▶ -0.10%

Use to set the correction value.  
Press to enable the setting.

Current correction value      Value to be set

#### To decide a Correction Value

Select the value to make the upper/lower rectangular gap and overlap smallest.

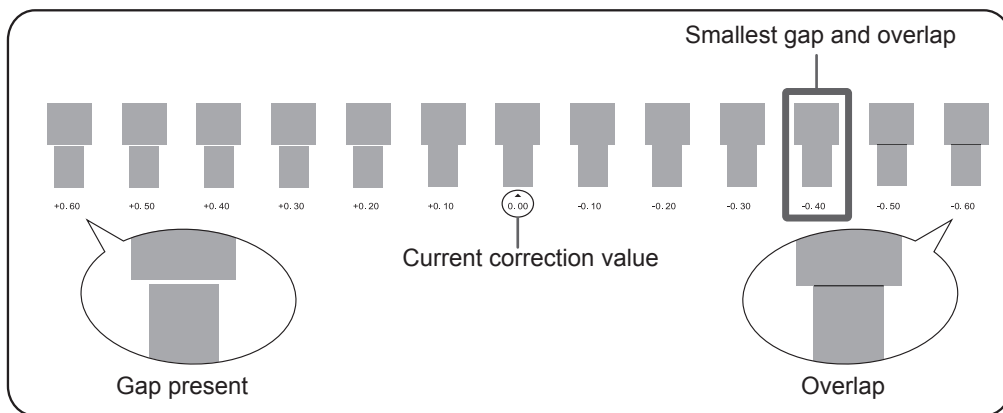

4 

|            |     |
|------------|-----|
| REDO ADJ.? | ◀ ▶ |
| YES [DONE] | ↵   |

[To confirm again/To adjust again]

Press to select [YES].

Press to enable the setting.

The test pattern of feed correction is output again. Go back to the procedure 3 and set again.

[To go to the next after correction is completed]

Press to select [DONE].

Press to enable the setting.

For the individual setting method of this setting item and the description, refer to P. 92, "Alleviating Horizontal Bands and the Like (feed correction function)"

## 5. Performing the correction for misalignment in bidirectional printing

**POINT!**

This machine prints by the bidirectional mode (in which the heads perform printing during both their outbound pass and return pass). This printing method is called "Bidirectional Printing." This method offers the advantage of being able to shorten output times, but subtle misalignment occurs during the outbound and return passes. The procedure to correct this and eliminate misalignment is "Bidirectional Correction."

1 

|               |     |
|---------------|-----|
| ADJUST BI-DIR | ◀ ▶ |
| [SET] NEXT    | ↵   |

Press to select [SET].

Press to enable the setting.

The test pattern of bidirectional correction is output.

2 

|             |   |
|-------------|---|
| INPUT       |   |
| ADJ. VALUES | ↵ |

When the left figure is displayed, press .

3 

|               |           |
|---------------|-----------|
| ADJUST BI-DIR | ⬆ ⬇ ⬅ ▶ ⬆ |
| 0 ▶ -6        | ↵         |

Use to select the correction value.

Press to enable the setting.

Current Value to be set  
correction value

**To decide a Correction Value**

Choose the value that produces the least misalignment of 2lines.

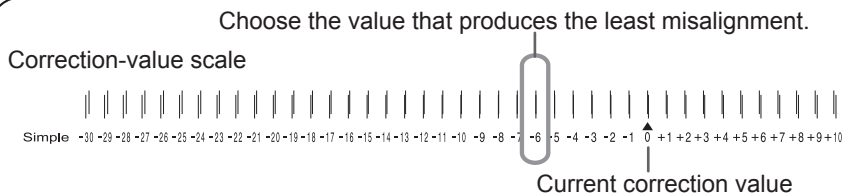

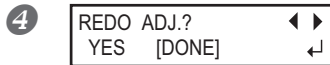

**[To confirm again/adjust again]**

Press to select [YES].

Press to enable the setting.

The test pattern of bidirectional correction is output again. Go back to the procedure **3** and set again.

**[To go to the next after correction is completed]**

Press to select [DONE].

Press to enable the setting.

For the individual setting method of this setting item and the description, refer to P. 91, "Correcting for Misalignment in Bidirectional Printing"

## 6. Deciding to perform the setting for cutting or not



**[Only Printing]**

Press to select [NEXT].

Press to enable the setting.

Go to Procedure **10**.

**[Printing & Cutting]**

Press to select [SET].

Press to enable the setting.

Go to Procedure **7**.

## 7. Setting the blade force

### POINT!

For high-quality cutting, perform a cutting test to check the cutting quality for the media and adjust the blade force.



Press to select [SET].

Press to enable the setting.

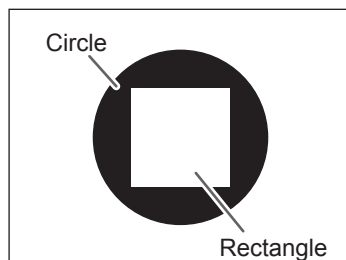

The test pattern is cut. Circle and rectangle are cut. Peel off the two shapes.

2

|                 |     |
|-----------------|-----|
| CONTINUE ADJ. ? | ◀ ▶ |
| [YES]      DONE | ↵   |

[Two shapes are peeled off separately]

Press **▶** to select [DONE].

Press **ENTER** to enable the setting.

Go to Procedure 8.

[Two shapes are peeled off together/backing paper is also cut]

Press **◀** to select [YES].

Press **ENTER** to enable the setting.

Go to Procedure 3.

3

|                    |   |
|--------------------|---|
| CUT FORCE          | ◆ |
| 50 gf      ▶ 50 gf | ↵ |

Current correction      Value to be set  
value

Use **▲** **▼** to adjust the blade force.

If two shapes are peeled off together ⇒ raise the blade force.

If backing paper is cut too ⇒ reduce the blade force.

Press **ENTER** to enable the setting.

Cut the test pattern again. Check the result.

4

|                 |     |
|-----------------|-----|
| REDO ADJ.?      | ◀ ▶ |
| YES      [DONE] | ↵   |

[Two shapes are peeled off separately]

Press **▶** to select [DONE].

Press **ENTER** to enable the setting.

Go to Procedure 8.

[Two shapes are peeled off together]

Press **◀** to select [YES].

Press **ENTER** to enable the setting.

Cut the test pattern again. Go back to the procedure 3 and set again.

For the individual setting method of this setting item and the description, refer to P. 101, "Fine-tuning the Cutting Conditions"

## 8. Correcting Misalignment for Printing and Cutting

### POINT!

Subtle misalignment between the printing and cutting positions may occur due to the thickness of the media or the head height. We recommend making correction to match the media you're using.

1

|                 |     |
|-----------------|-----|
| PRINT-CUT ADJ.  | ◀ ▶ |
| [SET]      NEXT | ↵   |

Press **◀** to select [SET].

Press **ENTER** to enable the setting.

The test pattern (P&C1) is printed and cut. The test pattern is printed at three locations on the media: at the two edges and in the center.

## 2 Check the test pattern condition.

### To check the test pattern (P&C1)

Check to make sure that the printing position and the cutting position are aligned.

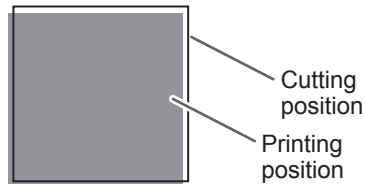

Cutting position and printing position are misaligned.



Cutting position and printing position are aligned.



### [Cutting position and printing position are aligned]

Press to select [DONE].

Press to enable the setting.

Go to Procedure 9.

### [Cutting position and printing position are not aligned]

Press to select [YES].

Press to enable the setting.

The test pattern (P&C2) for setting the correction values is printed and cut.

Go to Procedure 4.

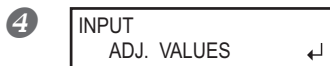

When the left figure is displayed, press .

## 5 Check the correction values from the test pattern condition.

### To check the test pattern (P&C2)

The point where the cutting line intersects the correction-value scale is the correction value. Check the scan direction and feed direction..

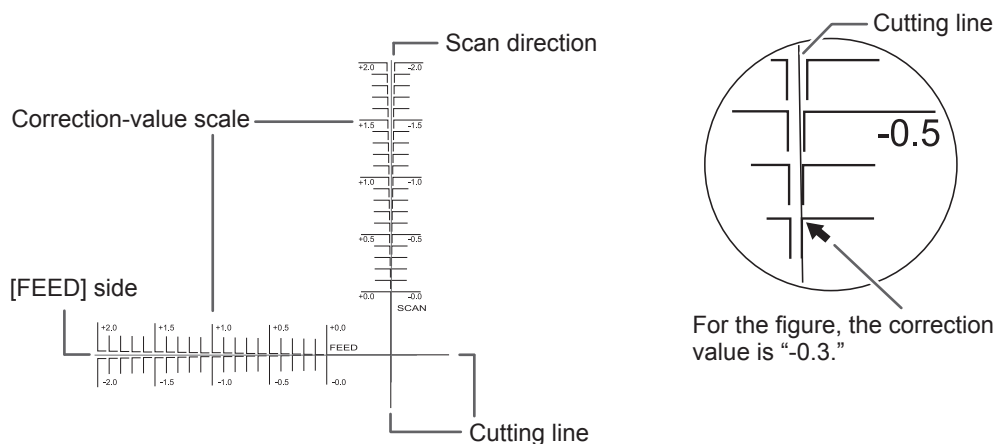

6

|           |   |          |   |
|-----------|---|----------|---|
| F :- 0.30 | ▶ | - 0.30mm |   |
| S : 0.00  | ▶ | - 0.20mm | ↵ |

Current correction Value to be set value

Use to set the correction value of FEED side (F).

Use to set the correction value of scan direction (S).

Press to enable the setting.

The test pattern (P&C1) is printed and cut again. Check the condition of test pattern to check that the printing position and the cutting position are aligned.

7

|            |     |
|------------|-----|
| REDO ADJ.? | ◀ ▶ |
| YES [DONE] | ↵   |

[Cutting position and printing position are aligned]

Press to select [DONE].

Press to enable the setting.

Go to Procedure 9.

[Cutting position and printing position are not aligned]

Press to select [YES].

Press to enable the setting.

Go back to Procedure 6, fine-tune the adjustment value, and then repeat Procedure 6 and 7 until the optimal alignment is got.

For the individual setting method of this setting item and the description, refer to P. 114, "Correcting Misalignment for Printing and Cutting Position When Using Crop Marks"

## 9. Correcting Misalignment for Printing and Cutting Position When Using Crop Marks.

### POINT!

When you remove the printed media, and then reload it and perform cutting, use the crop marks. For this case, correction is to be performed because the positioning of printing and cutting may be misaligned even when you're using crop marks depending on the composition of the media.

1

|               |     |
|---------------|-----|
| CROP-CUT ADJ. | ◀ ▶ |
| [SET] NEXT    | ↵   |

[To perform consecutive printing and cutting]

Press to select [NEXT].

Go to Procedure 10.

[To perform printing and cutting separately]

Press to select [SET].

Press to enable the setting.

The test pattern (C&C1) is printed and cut. Go to Procedure 2.



## 2 Check the test pattern condition.

### To check the test pattern (C&C1)

Check to make sure that the printing position and the cutting position are aligned.

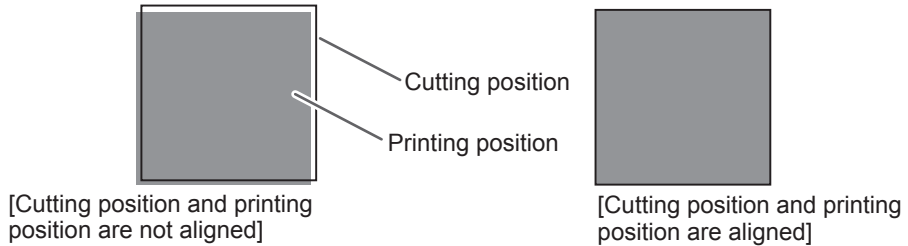

## 3 [Cutting position and printing position are aligned]

CONTINUE ADJ. ? ◀ ▶  
[YES] DONE ↵

Press **▶** to select [DONE].

Press **ENTER** to enable the setting.

Go to Procedure 10.

## [Cutting position and printing position are not aligned]

Press **◀** to select [YES].

Press **ENTER** to enable the setting.

The test pattern (C&C2) for setting the correction values is printed and cut.

## 4 When the left figure is displayed, press **ENTER**.

INPUT  
ADJ. VALUES ↵

## 5 Check the correction values from the test pattern condition.

### To check the test pattern (C&C2)

The point where the cutting line intersects the correction-value scale is the correction value. Check the scan direction and feed direction.

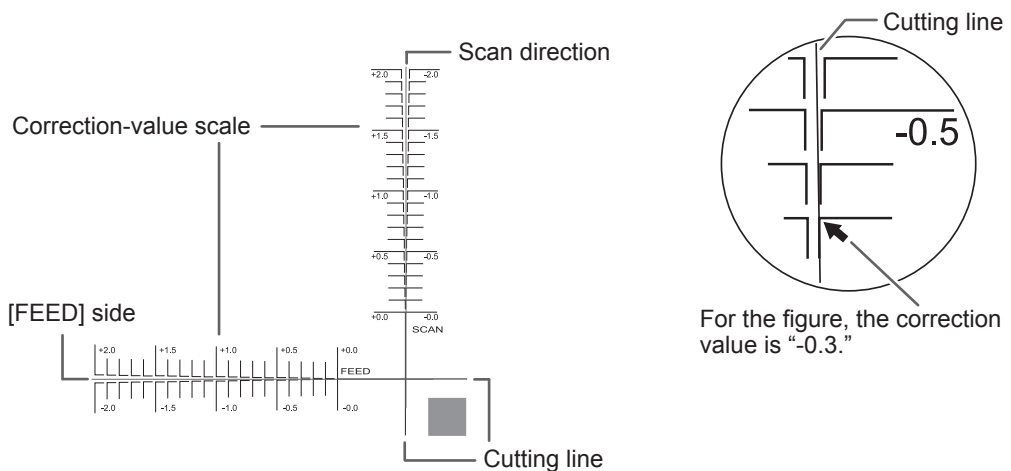

6

|           |   |          |   |
|-----------|---|----------|---|
| F :- 0.30 | ▶ | - 0.30mm |   |
| S : 0.00  | ▶ | - 0.20mm | ↵ |

Current correction value      Value to be set

Use   to set the correction value of [FEED] side (F).

Use   to set the correction value of scan direction (S).

Press  to enable the setting.

The test pattern (C&C1) is printed and cut again. Check the condition of test pattern to check that the printing position and the cutting position are aligned.

7

|            |    |
|------------|----|
| REDO ADJ.? | ◀▶ |
| YES [DONE] | ↵  |

**[Cutting position and printing position are aligned]**

Press  to select [DONE].

Press  to enable the setting.

Go to Procedure 10.

**[Cutting position and printing position are not aligned]**

Press  to select [YES].

Press  to enable the setting.

Go back to Procedure 6, fine-tune the adjustment value, and then repeat Procedure 6 and 7 until the optimal alignment is got.

For the individual setting method of this setting item and the description, refer to P. 105, "Correcting Misalignment of the Printing and Cutting Positions"

## 10. Setting the Drying Method and Time after Printing

1

|                  |   |
|------------------|---|
| FEED FOR DRY     | ◆ |
| DISABLE ▶ ENABLE | ↵ |

Current setting      Setting after changed

Press   to select the item.

Press  to enable the setting.

### **POINT!** Drying Method after Printing

After the 1st page is printed, set that the media should be fed until the trailing edge of the printed area is positioned directly on the dryer. To make sure to dry the entire printed area, select [ENABLE]. If [DISABLE] is selected, the trailing edge of the printing area is not fed to the dryer unless you continue with a subsequent printing operation.

For the individual setting method of this setting item and the description, refer to P. 88, "Drying the Trailing Edge of the Printing Area on the Dryer"

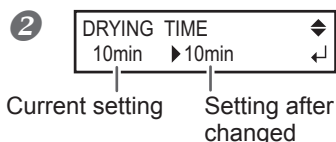

Press to set the item.

#### Example of setting time (general guide):

\*The setting time varies according to the settings of type of media and printing quality.

<Condition> Output accompanying pull-back; use the middle pinch rollers; non-coated vinyl media

<Setting time> about three minutes

Press to enable the setting.

#### **POINT!** Drying Time after Printing

Set the drying time after the 1st page is printed. The next operation is not started until the set time passes.

For the individual setting method of this setting item and the description, refer to P. 89, "Setting the Drying Time after Printing"

## 11. Saving the Setting as Preset

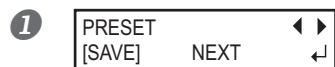

Press to select [SAVE].

Press to enable the setting.

If you select [NEXT], the performed settings are retained. But your settings are overwritten or deleted, when you operate the [Media Setting] menu again or switch off the main power of this machine.

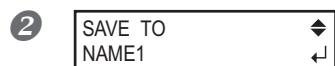

Use to select [Destination to Save].

You can select one of NAME1 to 8.

Press to enable the setting.



Use to select characters.

Use to move the next character.

Select the following characters in the same way.

You can enter up to 15 characters.

Press to enable the setting.



For the individual setting method of this setting item and the description, refer to P. 82, "Saving Various Settings as a Name Assigned Preset"

This completes the operation of the [Media Setting] menu.

## Setting the Output-start Location

You can set the output-start location at any location you prefer. (You can output if you do not set this.) Note, however, that this setting must be made for each individual page.

### Procedure

- 1 Open the front cover.
- 2 Use     to move the center of the blade with the output-start location.  
Only cutting carriage moves.

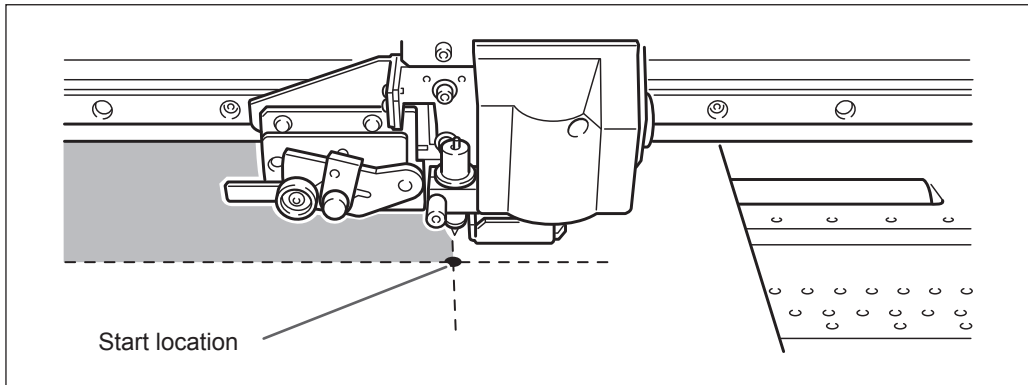

- 3 When the location is set, press .

W1100mm  
B

 remains steadily lighted and when the screen displays the character "B" together with the output-possible width at the location, setting is completed.

### POINT!

Note, however, that the left and right positions are not restored to their defaults for test patterns. If you're using the media take-up unit, never adjust by pressing . Doing so may pull the media with undue force, resulting in an error or malfunction.

## Printing Tests and Normal Cleaning

Before you carry out actual printing, we recommend performing a printing test to ensure no dot drop-out occurs. If dot drop-out occurs, perform cleaning of the print heads (Normal Cleaning).

### How to Perform a Printing Test

#### Procedure

- 1 **Setting the Output-start Location.**  
☞ P. 42, "Setting the Output-start Location"
- 2 **Holding down TEST PRINT for one second or longer.**  
 A test pattern is printed.

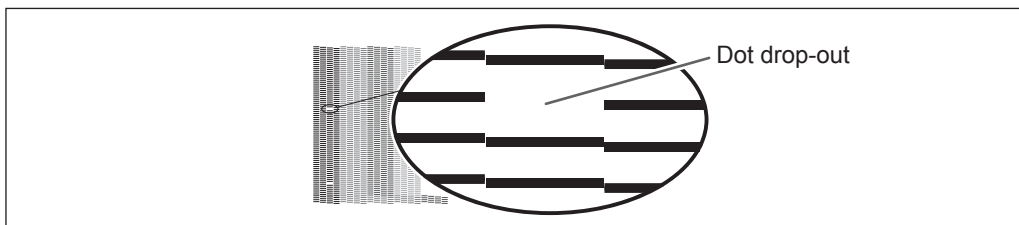

### How to Perform a Normal cleaning

#### Procedure





- 1 **Press CLEANING.**
- 2 

|            |    |
|------------|----|
| CLEANING   | ◀▶ |
| NORMAL CL. | ▶  |

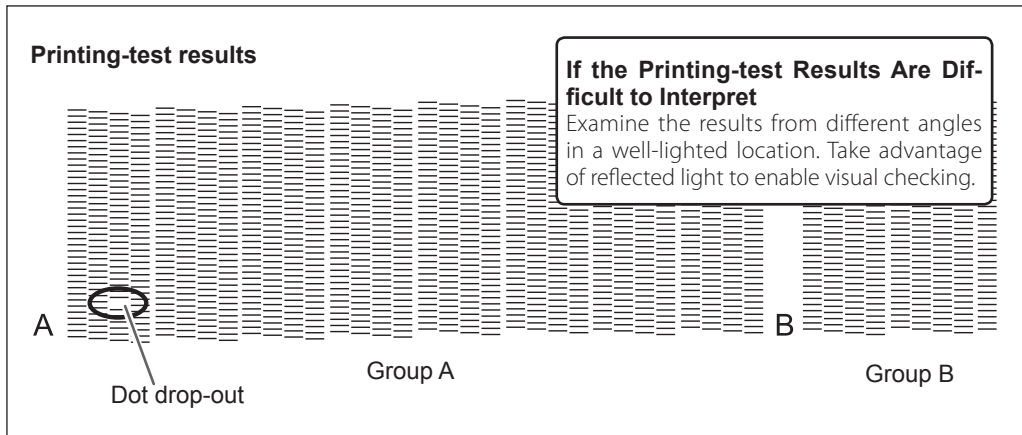
**Press ▶.**

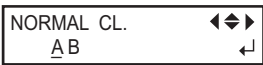
- 3 Check the group with dot drop-out by viewing the printing-test results.**  
With normal cleaning, only groups of the print head having dot drop-out are cleaned.



- 4**  **Press**   **to choose the group of heads that is not to be cleaned.**  
**Press**   **to get rid of the group display.**  
**Repeat this procedure to display the groups of only the heads that require cleaning.**

Only groups that is either A or B is displayed are objective for cleaning.

- 5** **Press** .

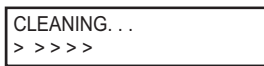

The screen shown in the figure appears and cleaning starts.

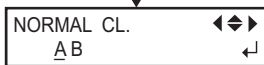

When it finishes, the screen shown in the figure appears again.

- 6** **Press**   **in this order to go back to the original screen.**

- 7** **Perform a printing test again to make sure the dot drop-out has been corrected.**

If the problem persists, try performing cleaning a second time. If the printer has been used for a long period, the problem may persist even after two or three-cycle cleaning. Then try cleaning using a different method.

☞ P. 59, "When Normal Cleaning Is Not Effective"

---

### When you want to clean all heads simultaneously

---

Hold down  for one second or longer. Cleaning for all heads starts automatically.

## Important Note on Cutting

***When you're performing cutting only, never use the media clamps.***

When you're performing cutting only, remove the media clamps or move to the locations where they don't clamp the media.

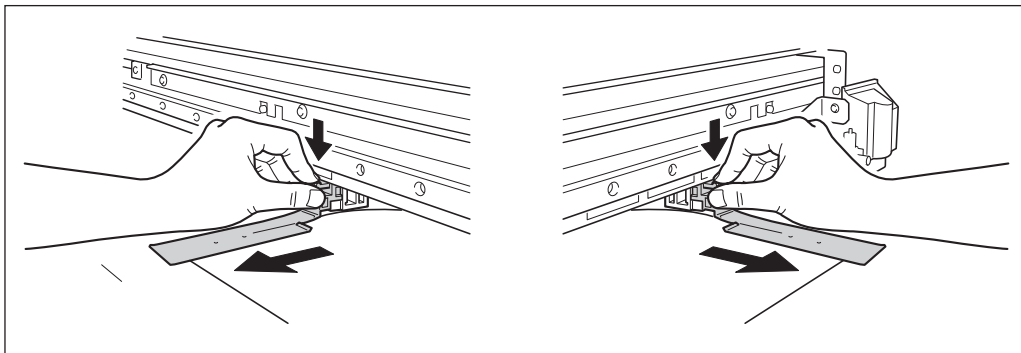

***When using the roll media and only performing cutting, let the media hang down to the rear of the machine. (or set the [PREFEED] menu to "ENABLE.")***

This prevents a motor error or fall of the roll because the media is pulled with excessive force.

For the [PREFEED] menu, refer to P. 31, "Setup of Media ([Media Setting] menu)"

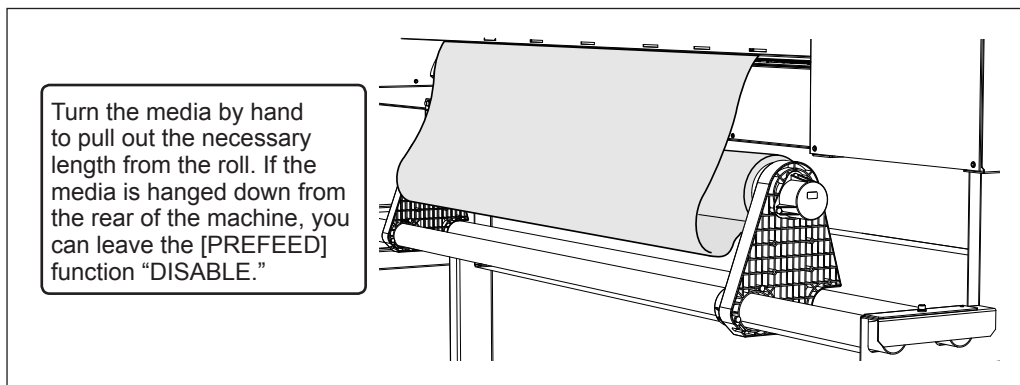





***When you're performing printing followed immediately by cutting (Print and Cut), then before you start cutting, allow the ink to dry sufficiently.***

Use your software RIP to make the setting for the drying time. For information on how to make the setting, refer to the documentation for the software RIP you're using. The drying time varies according to the media.

## Setting The Cutting Test And The Blade Force

For high-quality cutting, then before you perform actual cutting, we recommend carrying out a cutting test to check the cutting quality for the media. Adjust the blade force depending on the cutting quality.

### 1. Carrying out the cutting test

- 1 Press     to move the cutting carriage to the location where you want to carry out the cutting test.

You can freely set the location for the cutting test.

- 2 Close the front cover.

- 3 Hold down  for one second or longer..

The test pattern is cut.

- 4

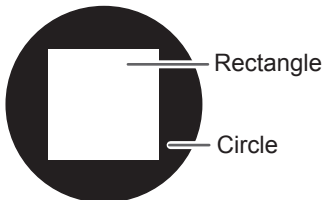

Peel off the cut shapes to verify the cutting quality. [Two shapes are peeled off separately]

You do not need to perform the setting because the blade force is appropriate.

[Two shapes are peeled off together/backing paper is also cut]

Go to the next Procedure to set the blade force.

### 2. Setting the blade force.

- 1 Press .

- 2 

Press   to select the value.

[Two shapes are peeled off together]

Raise the blade force.

[Backing paper is also cut]

Reduce the blade force.

Press  to enable the setting.

Go back to the original screen.

Pressing  enters the cutting configuration menu. You can also make the settings for other cutting conditions in addition to the blade force. Refer to the following pages. Refer to the following pages.

☞ P. 101, "Fine-tuning the Cutting Conditions"



## Getting Ready to Receive Data from a Computer

When P. 19, "Loading Media" and P. 31, "Setup of Media" are completed, get ready to receive the data from a computer.



**Never touch the print heads while output is in progress.**  
The print heads move at high speed. Hitting may cause injury.

### Procedure

- 1 Close the front cover.
- 2 Make sure **SET UP** stays steadily lit.  
If **SET UP** is not lit, pull the loading lever and press **SET UP**.
- 3 Wait until **HEATER CONFIG** stays steadily lit.
- 4 Make sure the top menu is displayed.  
If the top menu is not displayed, press **MENU**, then press **◀**.

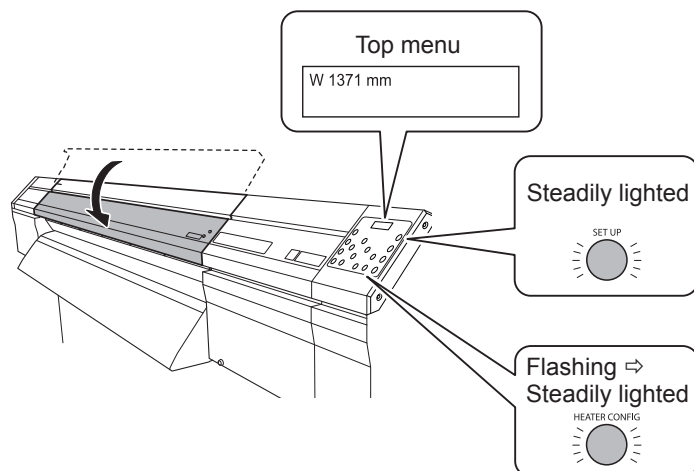

### POINT!

#### Output Is Not Possible in These Situations

- The machine does not run when the front cover is open.
- Never open it when printing is in progress. Doing so interrupts printing.
- Data from the computer is not accepted when **SET UP** is dark.
- Printing does not start until **HEATER CONFIG** lights up. (If all of the pre-heater, print-heater, and dryer are set to "OFF," printing is possible even if **HEATER CONFIG** is not lit.)
- Data from the computer is not accepted when you are not at the top menu.

## Starting Output

When the operation of P. 47, "Getting Ready to Receive Data from a Computer" is completed, you can start output. To output, the following procedure is required.

### ① Creating Output Data

Create the output data using the application software like Adobe Illustrator and like that. For information on how to create the data, refer to the documentation of your application software.

### ② Sending the Output Data to This Machine Using the Software RIP.

Use the included software RIP "VersaWorks series. For information on how to install and use VersaWorks, refer to the "VersaWorks Install Guide" and the HELP of VersaWorks.

- VersaWorks Dual
  - ☞ <https://webmanual.rolanddg.com/RolandVersaWorksDual>
- VersaWorks 6
  - ☞ <https://webmanual.rolanddg.com/VersaWorks6>

If using the white ink and metallic silver ink, refer to "Special Color Ink Guide."

- ☞ <https://webmanual.rolanddg.com/XR-640>

#### **IMPORTANT!** Points that must be observed

- Be sure to set the media clamps during printing. Otherwise the edges of the media may warp and catch on the print heads.
- During output, never touch the media that's already been discharged. Doing so may obstruct media feed or cause the media to rub against the heads, which may result in a paper jam or damage to the heads.
- Press back the loading lever when the machine is not in use.

#### **POINT!**

##### If Ink Runs Out

When ink runs out, a warning beep sounds and a slot number of which ink runs out is displayed on the display screen. Exchange the ink cartridge.

- ☞ P. 54, "How to Replace Ink Cartridges"

Before you perform lengthy printing, check the amount of ink remaining in the ink cartridges.

Before you perform lengthy printing, check the amount of ink remaining in the ink cartridges. When ink runs out and printing is paused, the coloring at the seam may be altered when printing resumes.

- ☞ P. 53, "Checking for Remaining Ink"

## Pausing and Canceling Output

You can pause and cancel printing before it finishes. We do not recommend resuming printing because horizontal stripes are produced at the place where output stopped.

### Procedure

- 1 **Press** **PAUSE** **before output finishes.**  
This pauses printing operation.  
**Press** **PAUSE** **again to resume printing.**  
To cancel the output, go the next Procedure without pressing **PAUSE**.
- 2 **TO CANCEL, HOLD DOWN SETUP KEY** **When the screen shown in the figure appears, hold down** **SET UP** **for one second or longer.**  
This cancels printing operation.
- 3 **Stop sending the output data from the computer.**

## Cutting Off the Media

### Procedure

- 1 **Close the front cover.**
- 2 **Make sure** **SET UP** **lights up.**
- 3 **Hold down** **SHEET CUT** **for one second or longer.**

REMOVE  
MEDIA CLAMPS ←

When the media clamps are attached, the screen shown in the figure appears. Open the front cover, remove the right and left media clamps, and then press **ENTER**.

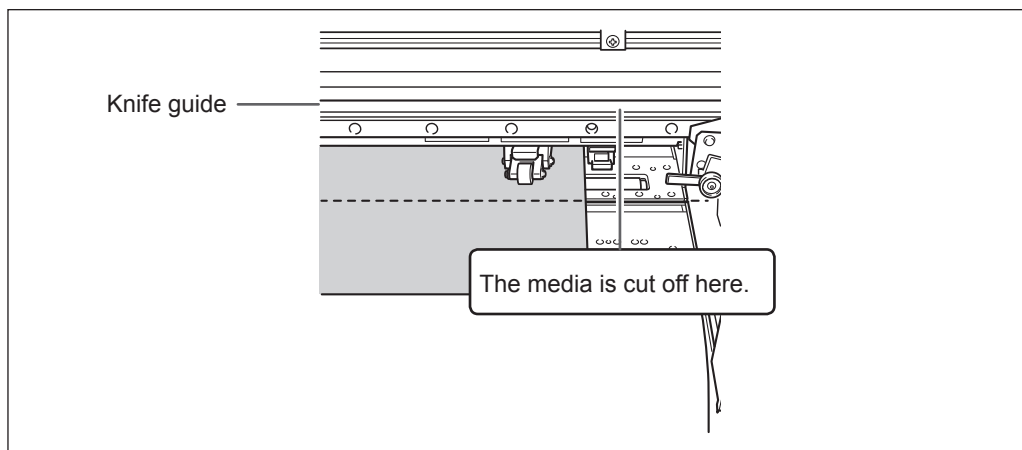

You can make the setting in the software RIP for automatic media cutoff after printing or cutting has finished. For information on how to make the setting, refer to the documentation for the software RIP you're using.

### **IMPORTANT!** Cut-off Operations

- Be sure to detach the media clamps. Performing cutoff with the media clamps remaining attached may cause the operation to be interrupted due to detection of the media clamps.
- If the media clamps are present on the machine when the setting to execute automatic cutoff of the media is made on the computer, the media clamps are detected and no cutoff operation is performed
- Before you're performing cutoff, never use  to pull the media back. Unless the end of the media has been pulled out to a location to the front of the platen, cutoff may not be performed smoothly.

### **IMPORTANT!** Give Attention to Media Composition

- For some types of media, cutoff is not possible.
- Some types of media may remain on the platen after cutoff. If the media remains on the platen, remove it by hand.

# Switch Off

## Switch Off

### **⚠️ WARNING**

**When output is not being performed, remove any loaded media or switch off the sub power.**

The continued application of heat at a single location may cause the release of toxic gases from the media or pose a fire hazard.

### Procedure

1

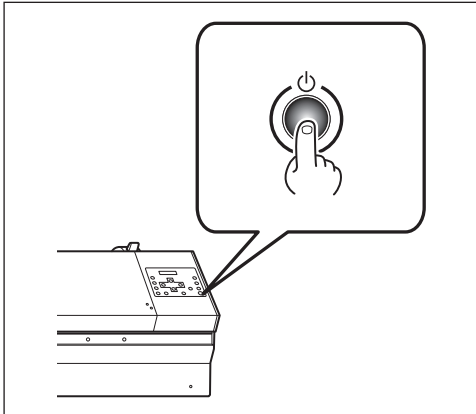

**Hold down the sub power button for one second or longer.**

The sub power is turned off. Perform this process after output is finished.

2

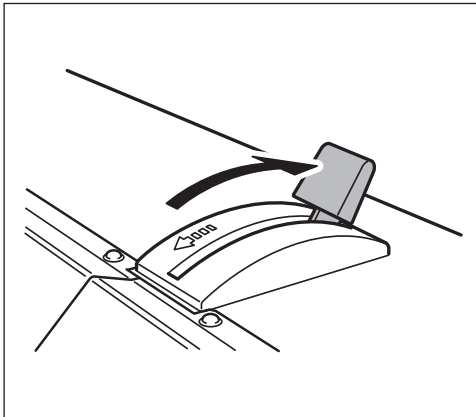

**Press back the loading lever.**

Press back the loading lever when the machine is not used even if the power is not turned off.

### **IMPORTANT!**

Leave the main power switched on at all times.

Never switch off the main power. By switching on the main power, the automatic maintenance function is carried out periodically. If the automatic maintenance is not carried out, it may result in breakdown of this machine such as breakdown of the print heads.

Never switch off the main power or unplug the power cord suddenly while operation is in progress.

Switching off the main power or unplugging the power cord suddenly while operation in progress may damage the print heads. Be sure to first switch off the sub power.

If the main power is accidentally switched off, immediately turn the power back on.

2

Basic  
Operation

# Chapter 3

## ***Maintenance:***

*For always using the printer in the best condition*

---

|   |    |
|---|----|
| Checking for Remaining Ink and Replacing Cartridges .....   | 53 |
| Checking for Remaining Ink .....                            | 53 |
| How to Replace Ink Cartridges .....                         | 54 |
| Maintenance that Should Be Performed Daily .....            | 55 |
| Disposing of Discharged Fluid .....                         | 55 |
| Cleaning .....  | 57 |
| About Care and Maintenance of Print Heads .....             | 58 |
| When Normal Cleaning Is Not Effective .....                 | 59 |
| Medium Cleaning .....                                       | 59 |
| Powerful Cleaning .....                                     | 60 |
| Manual Cleaning of Print Heads .....                        | 61 |
| When Manual-Cleaning Becomes Necessary .....                | 61 |
| Manual Cleaning of Print Heads .....                        | 62 |
| When Problems Such As Dot Drop-out are Not Cleared Up ..... | 66 |
| When Problems Such As Dot Drop-out are Not Cleared Up ..... | 66 |
| Replacing Consumable Parts .....                            | 68 |
| Replacing the Wiper .....                                   | 68 |
| Replacing the Felt Wiper .....                              | 71 |
| Replacing the Blade .....                                   | 74 |
| Replacing the Separating Knife .....                        | 76 |
| When Not in Use for a Prolonged Period .....                | 78 |
| Keep Performing Maintenance .....                           | 78 |
| Alarm Feature .....   | 78 |
| When Not in Use for a Prolonged Period, Precaution 1 .....  | 78 |
| When Not in Use for a Prolonged Period, Precaution 2 .....  | 78 |
| Special Maintenance .....                                   | 80 |
| Draining Ink and Performing Internal Washing .....          | 80 |
| Draining Ink Remaining Inside the Machine .....             | 80 |

# Checking for Remaining Ink and Replacing Cartridges

## Checking for Remaining Ink

### Procedure

1 Press **MENU**.



Press **▲** several times until the screen shown on the left appears.

Press **▶**.

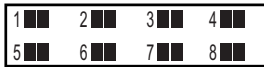

■ indicates the amount of ink remaining. When there are more ■, the amount of ink remaining is larger.

\* The display shows an approximate guide to the amount of remaining ink. It may differ somewhat from the actual amount remaining.

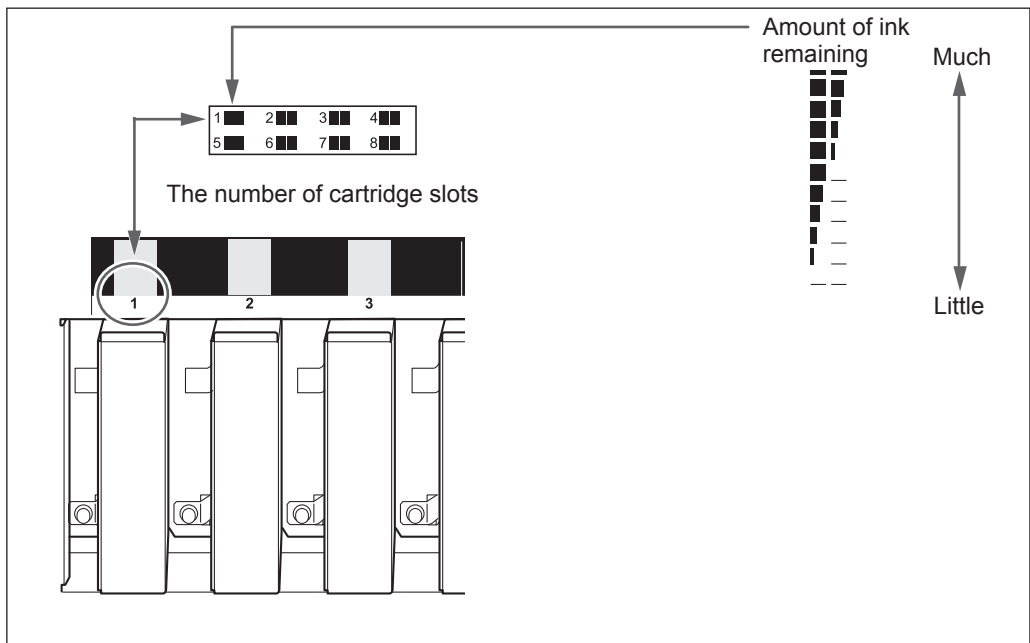

3 Press **MENU** **◀** in this order to go back to the original screen.

## How to Replace Ink Cartridges

When ink runs out, a warning beep sounds and printing pauses (unless the factory default settings have been changed). Pull out the empty cartridge and insert a new one. Printing resumes.

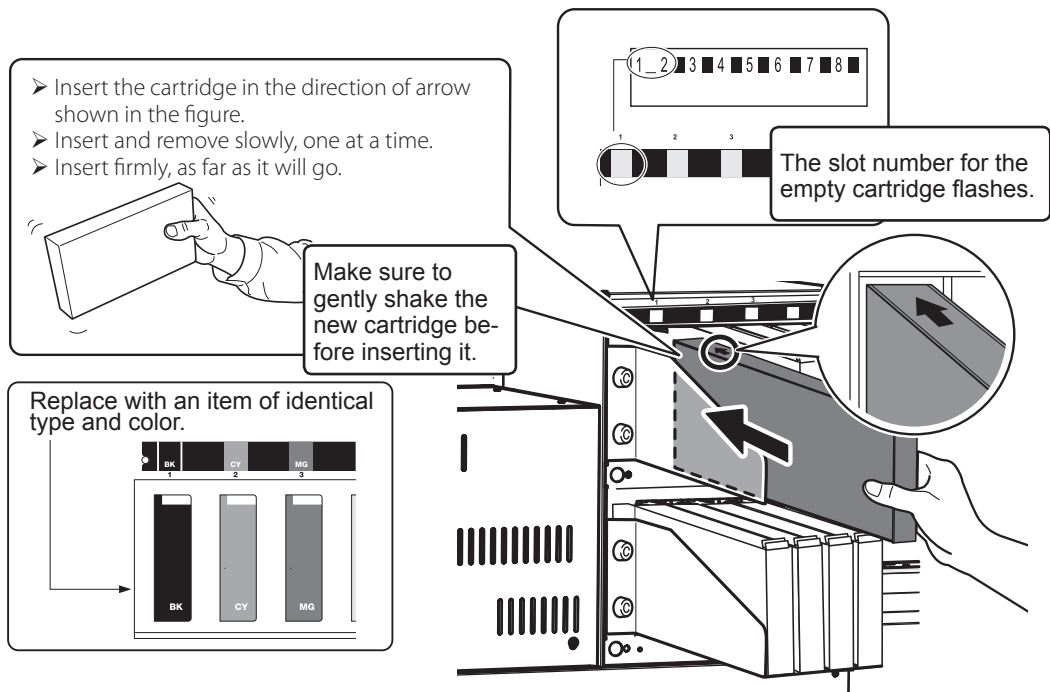

### **IMPORTANT!** Important Notes on Replacing Cartridges

- Insert and remove slowly, one at a time.
- Be sure to replace with an item of identical type.
- Never use an ink cartridge which has already been used in other machines even if it is of the identical type.
- Never mix items of different types.
- Never allow the machine to stand with an ink cartridge removed. The print heads may become clogged.
- Never insert or remove a partially used ink cartridge.
- Never remove an ink cartridge suddenly while the printer is in operation.

### **⚠ WARNING**

**Never store ink, cleaning liquid, or discharged fluid in any of the following locations.**

- Any location exposed to open flame
- Any location where high temperature may occur
- Near bleach or any other such oxidizing agent or explosive material
- Any location within the reach of children

Fire may be a danger. Accidental ingestion by children may pose a health hazard.



# Maintenance that Should Be Performed Daily

## Disposing of Discharged Fluid

CHECK  
DRAIN BOTTLE

The drain bottle collects discharged fluid. Dispose of collected material before the bottle becomes full. The message shown in the figure appears when a certain amount of discharged fluid has collected in the bottle. Follow the procedure below to discard the discharged fluid.

### Procedure

1 CHECK  
DRAIN BOTTLE

When the message shown in the figure appears, press **ENTER**.

2 Press **MENU**.

3 MENU  
SUB MENU

Press **▼** several times until the screen shown on the left appears.

Press **▶**, and then **▲**.

4 SUB MENU  
MAINTENANCE

Press **▶**, and then **▲**.

5 MAINTENANCE  
DRAIN BOTTLE

Press **ENTER**.

6 EMPTY  
DRAIN BOTTLE

When the screen shown on the left appears, detach the bottle, discard the discharged fluid to empty it.

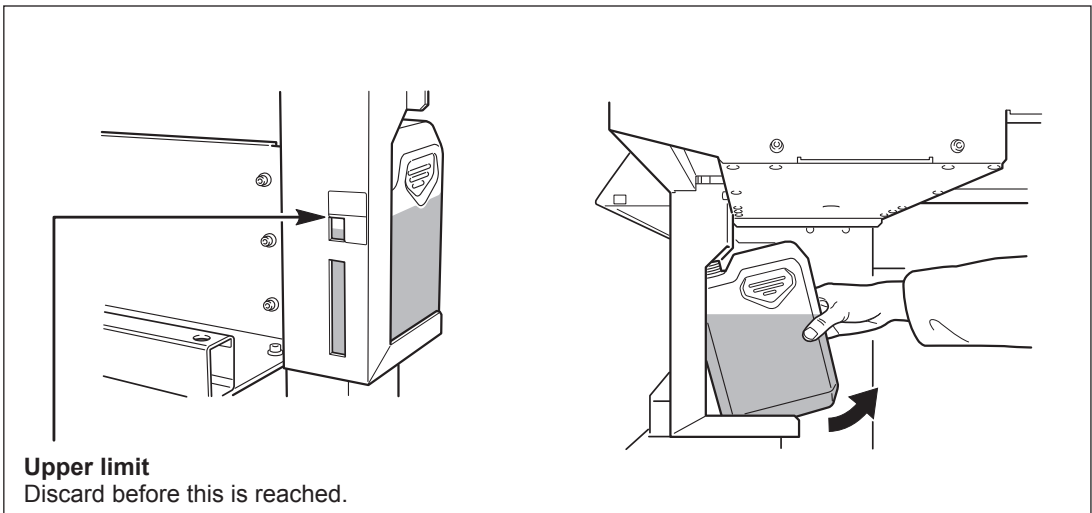

### ⚠ CAUTION

Before you detach the drain bottle, be sure to wait for the screen to display **"EMPTY DRAIN BOTTLE."**

Failing to follow this procedure may cause discharged fluid to flow out of the tube and spill, soiling your hands or the floor.



Attach the emptied drain bottle to the machine.  
Press **ENTER**.



Press **ENTER**.

9 Press **MENU** **←** in this order to go back to the original screen.

**⚠ WARNING** Never place discharged fluid near open flame.  
Doing so may cause fire.

**⚠ CAUTION** To store discharged fluid temporarily, place it in the included drain bottle or in a durable sealed container such as a metal can or polyethylene tank, and cap tightly.  
Any spillage or vapor leakage may cause fire, odor, or physical distress.

***Store discharged fluid in a location not exposed to direct sunlight.***

---

When temporarily storing discharged fluid in the included drain bottle, keep the drain bottle out of direct sunlight. Otherwise the discharged fluid may harden, the waste bottle may become unusable, or the waste bottle may be deteriorated, the discharged fluid may leak.

***Dispose discharged fluid properly, in accordance with the laws in effect in your local.***

---

Discharged fluid is flammable and contains toxic ingredients. Never attempt to incinerate discharged fluid or discard it with ordinary trash. Also, do not dispose of it in sewer systems, rivers, or streams. Doing so may have an adverse impact on the environment.

## Cleaning

### ⚠️ WARNING

Never use gasoline, alcohol, thinner, or any other flammable material. Doing so may cause fire.

### ⚠️ CAUTION

Before attempting cleaning, switch off the sub power and wait until the platen and dryer cool (approximately 30 minutes).

Sudden movement of the machine may cause injury, or hot components may cause burns.

Wipe away any buildup of ink or grime on the media path and other locations as daily cleaning. In particular, the pinch rollers, grit rollers, and platen are likely to get a buildup of grime. Clean by wiping with a cloth moistened by neutral detergent diluted with water then wrung dry.

### POINT!

- This machine is a precision device, and is sensitive to dust and dirt. Perform cleaning on a daily basis.
- Never attempt to oil or lubricate the machine.

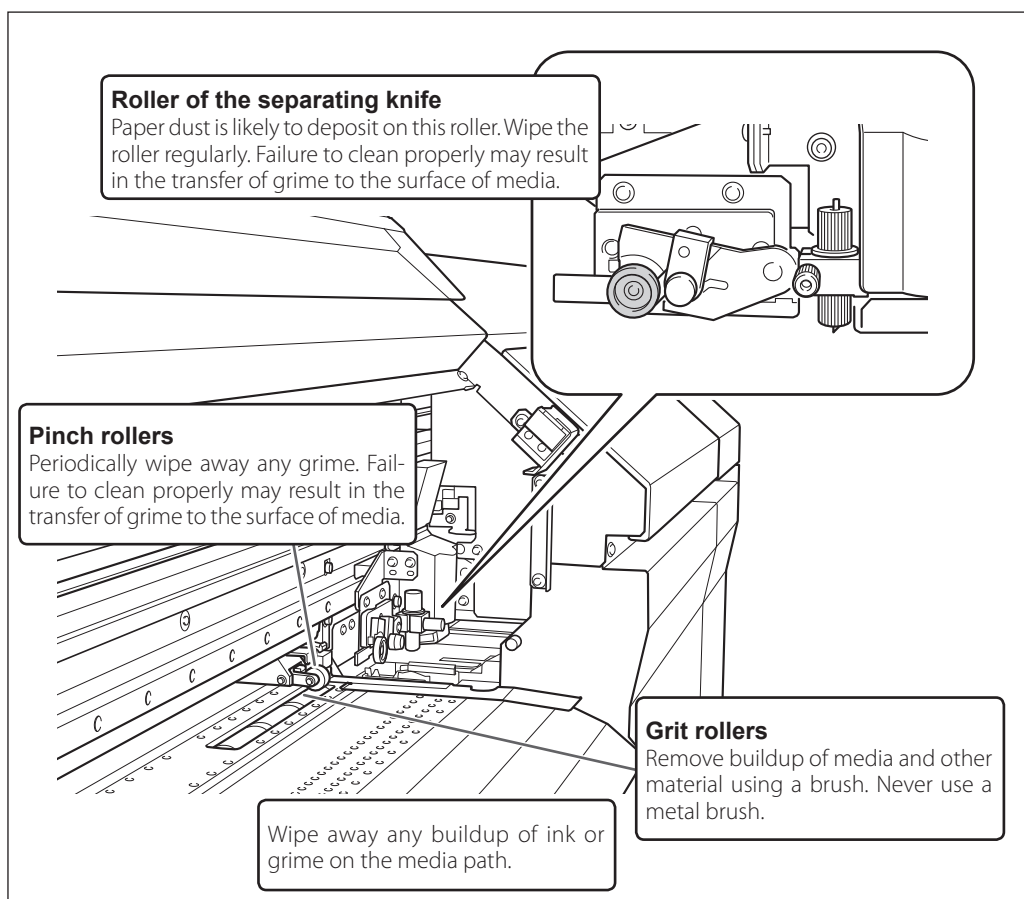

## About Care and Maintenance of Print Heads

Care of the print heads is essential to ensuring optimal printing at all times. There are daily care and periodic care.

### When Using ECO-SOL MAX 2 Ink

| Cleaning timing   | Cleaning method                | Page  | Remarks  |
|---|--------------------------------|-------|--|
| Before daily operations   | Normal cleaning                | P. 43 | Carry out a printing test. If dot drop-out occurs, perform cleaning.   |
| When dot drop-outs are not fixed by performing normal cleaning multiple times   | Medium cleaning                | P. 59 | <ul style="list-style-type: none"> <li>• If dot drop-outs are not fixed by performing medium cleaning, perform powerful cleaning.</li> <li>• This consumes more ink than normal cleaning, and too-frequent use may damage the print heads themselves. Avoid using it more than necessary.</li> </ul> |
|   | Powerful cleaning              | P. 60 |  |
| <ul style="list-style-type: none"> <li>• Once per month</li> <li>• When symptoms cannot be improved with medium or powerful cleaning</li> </ul> | Manual Cleaning of Print Heads | P. 62 | <ul style="list-style-type: none"> <li>• We recommend that you perform this cleaning periodically.</li> <li>• Replacing the wiper and felt wiper is also an effective means of improving the symptoms.</li> </ul>  |

### When Using ECO-SOL MAX 3 Ink

| Cleaning timing  | Cleaning method                    | Page  | Remarks  |
|--|------------------------------------|-------|--|
| Before the start of operations   | Normal cleaning                    | P. 43 | Carry out a printing test. If dot drop-out occurs, perform cleaning.   |
| If the message "TIME FOR MAINTENANCE" is displayed (approximately once per week) | Manual cleaning of the print heads | P. 62 | "TIME FOR MAINTENANCE" is displayed approximately once per week, but it may be displayed more frequently depending on the usage conditions. When this message is displayed, be sure to perform manual cleaning.  |
| When dot drop-outs are not fixed by performing normal cleaning multiple times    | Medium cleaning                    | P. 59 | <ul style="list-style-type: none"> <li>• If dot drop-outs are not fixed by performing medium cleaning, perform powerful cleaning.</li> <li>• This consumes more ink than normal cleaning, and too-frequent use may damage the print heads themselves. Avoid using it more than necessary.</li> </ul> |
|  | Powerful cleaning                  | P. 60 |  |
| When symptoms cannot be improved with medium or powerful cleaning                | Manual Cleaning of Print Heads     | P. 62 | Replacing the wiper and felt wiper is also an effective means of improving the symptoms.   |

\*The print head is component that wears out. Periodic replacement is required, with the frequency of replacement depending on use. Purchase them from your authorized Roland DG Corp. dealer.

# When Normal Cleaning Is Not Effective

## POINT!

Note, however, that the medium and powerful cleaning consumes more ink than normal cleaning, and too-frequent use may damage print heads themselves. Avoid using it more than necessary.

## Medium Cleaning

Perform the more powerful "medium cleaning" to solve a print head jam when the problems such as dot drop-out are not cleared up by the normal cleaning (P. 43, "Printing Tests and Normal Cleaning") occur.

### Procedure

#### 1 Perform a printing test.

☞ P. 43, "How to Perform a Printing Test"

When a printing test is completed, be sure to remove the media.

#### 2 Press **CLEANING**.





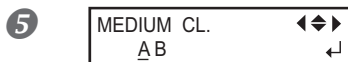
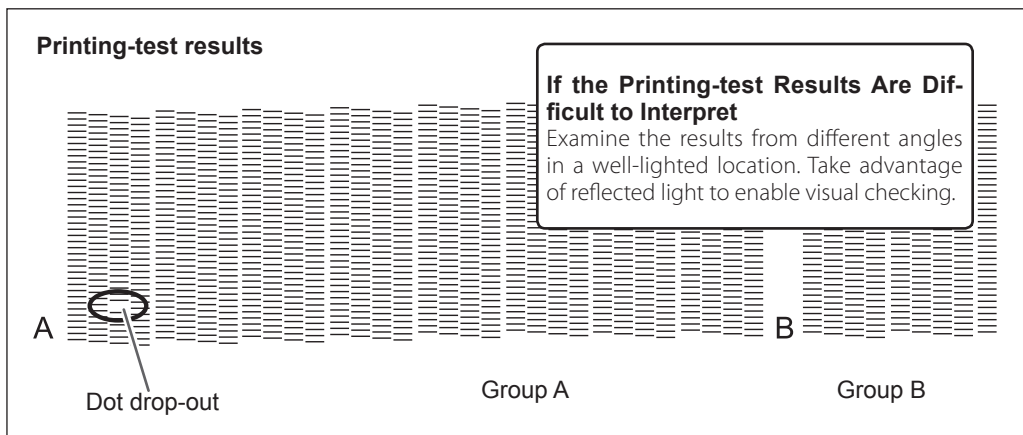

Press  to display the left figure.  
Press .

#### 4 Check the group with dot drop-out by viewing the printing-test results.

With medium cleaning, only groups of the print head having dot drop-out are cleaned.



Press   to choose the group of heads that is not to be cleaned.

Press   to get rid of the group display.  
Repeat this procedure to display the groups of only the heads that require cleaning.

Only groups that is either A or B is displayed are objective for cleaning.

- 6 Press **ENTER** .

```
CLEANING. . .
>>>>>
```

The screen shown in the figure appears and cleaning starts.

```
MEDIUM CL.  ◀▶
  A B        ↵
```

When it finishes, the screen shown in the figure appears again.

- 7 Press **MENU** **◀** in this order to go back to the original screen.

Perform stronger “powerful cleaning” when the problems such as dot drop-out are not cleared up by the medium cleaning.

## Powerful Cleaning

### Procedure

- 1 Press **CLEANING** .

```
CLEANING  ◀▶
POWERFUL CL.  ↵
```

Press **▲** to display the left figure.

Press **ENTER** .

```
CLEANING. . .
>>>>>
```

The screen shown in the figure appears and cleaning starts.

```
CLEANING  ◀▶
POWERFUL CL.  ↵
```

When it finishes, the screen shown in the figure appears again.

- 3 Press **MENU** **◀** in this order to go back to the original screen.

### When Powerful Cleaning Is Not Effective

When the problems such as dot drop-out are not cleared up even by performing powerful cleaning several times, perform “Manual Cleaning of Print Heads.”

☞ P. 62, “Manual Cleaning of Print Heads”

# Manual Cleaning of Print Heads

## When Manual-Cleaning Becomes Necessary

### Time Frames for Periodic Cleaning

The time frame for periodic cleaning varies depending on the ink.

| Ink           | When maintenance is necessary  |
|---------------|--|
| ECO-SOL MAX 2 | Once a Month<br>If the message "TIME FOR MAINTENANCE" is displayed (approximately once per week) |
| ECO-SOL MAX 3 | If the message "TIME FOR MAINTENANCE" is displayed (approximately once per week)                 |

### When the Following Symptoms Occur

It is recommended to perform the manual cleaning when any of the symptoms given below occurs and it cannot be solved by the automatic cleaning functions such as the normal cleaning.

For your information, replacement of the wiper or felt wiper is also effective to improve the symptoms.

- ☞ P. 54, "How to Replace Ink Cartridges"
- ☞ P. 53, "Checking for Remaining Ink"

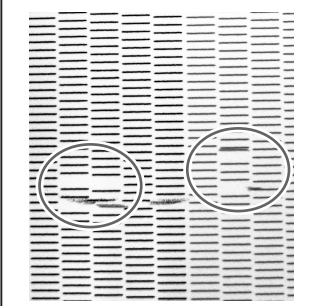
| Dot drop-out or deflection  |
|---|
|  |
| Flaws in the dot pattern are caused by dust on the print heads.                     |

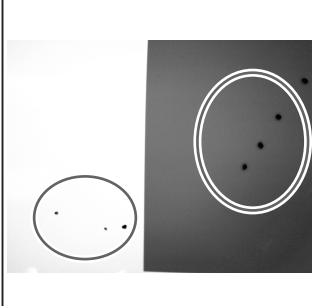
| Ink drips   |
|---|
|  |
| Ink that has adhered to dirty or dusty print heads drips onto the media.            |

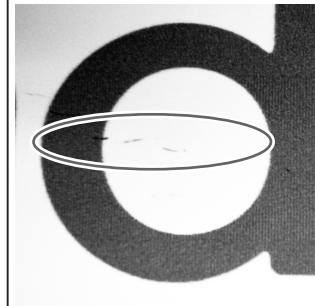
| Dragging dirt   |
|---|
|   |
| When dirt or dust accumulates on the print heads it can interfere with image quality. |

- When the cleaning stick and cleaning liquid for the manual cleaning runs out, place an order for them with your authorized Roland DG Corp. dealer.
- The print heads are components that wear out. Periodic replacement is required, with the frequency of replacement depending on use. Purchase them from your authorized Roland DG Corp. dealer.

## Manual Cleaning of Print Heads

### IMPORTANT!

#### Important Notes on This Procedure

- Before attempting this operation, remove any media.
- To prevent the heads from drying out, finish this procedure in 30 minutes or less. A warning beep sounds after 30 minutes.
- Never use any implement other than the included cleaning stick. Cotton swabs or other lintproducing items may damage the heads. If you use up the cleaning stick, purchase a new one from your authorized Roland DG Corp. dealer.
- Use one cleaning stick per cleaning session, then discard the stick after use. Reusing cleaning sticks may reduce printing quality.
- Do not put the cleaning stick used for cleaning into the cleaning liquid. It will deteriorate the liquid.
- Never rub the nozzle surface of the print heads.
- Stroke the sponges very gently, applying as little pressure as possible. Never rub, scrape, or crush them.

#### When a warning beep sounds during cleaning

A warning beep sounds in 30 minutes after the operation is started. At this time, stop work, and follow the procedure in step 3. on page 86 to attach cover L and cover R, then close the front cover. Press **ENTER** to quit the manual-cleaning menu. After that, restart the procedure from the beginning.

**⚠ CAUTION** Be sure to perform operations as specified by the instructions above, and never touch any area not specified in the instructions. Sudden movement of the machine may cause injury.

## 1. Change to the print-head manual-cleaning menu.

1 Remove any media

2 Press **MENU**.

3 

|          |    |
|----------|----|
| MENU     | ◀▶ |
| SUB MENU | ▶  |

Press **▼** several times until the screen shown on the left appears.

Press **▶**, and then **▲**.

4 

|             |    |
|-------------|----|
| SUB MENU    | ◀▶ |
| MAINTENANCE | ▶  |

Press **▶**.

5 

|             |    |
|-------------|----|
| MAINTENANCE | ◀▶ |
| CLEANING    | ↵  |

Press **ENTER**.

The print-head carriage moves to the left side of the machine.



**6** OPEN COVER R

When the screen shown on the left appears, open the cover R.

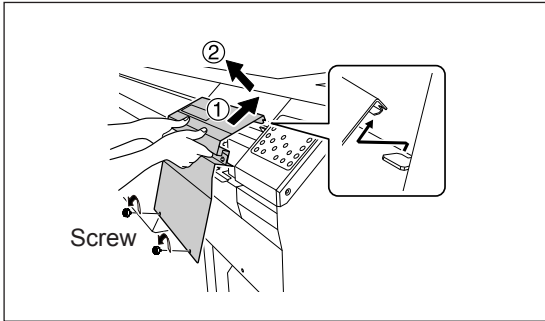

Remove the screws, lift the cover R in the direction of ①, and then pull it out in the direction of ②.

**7** OPEN COVER R

Open the cover L.

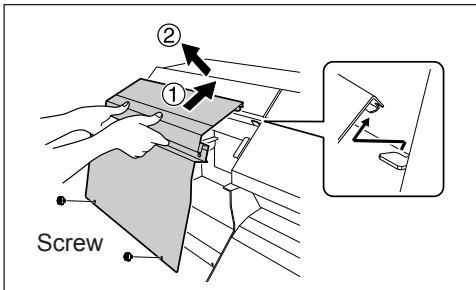

Remove the screws, lift the cover R in the direction of ①, and then pull it out in the direction of ②.

FINISHED? ↙

Preparations are complete when this screen appears.

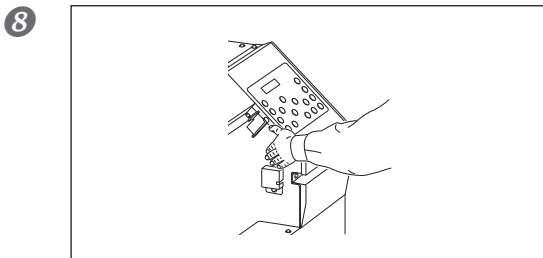

Touch the location shown in the figure to discharge any static electricity.

**2. Clean using the cleaning stick.**

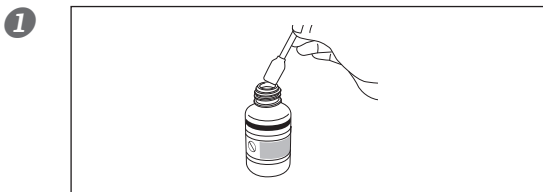

Moisten the cleaning stick with the cleaning liquid.

**2 Perform cleaning in the place shown in the figure below.**

Exercise special care in wiping off any accumulated ink. You can make the accumulated ink easier to clean off by applying cleaning liquid to the cleaning locations, and then wiping these locations off with the cleaning stick. Only moisten the part indicated with diagonal lines in location **A** with cleaning liquid on the cleaning stick.

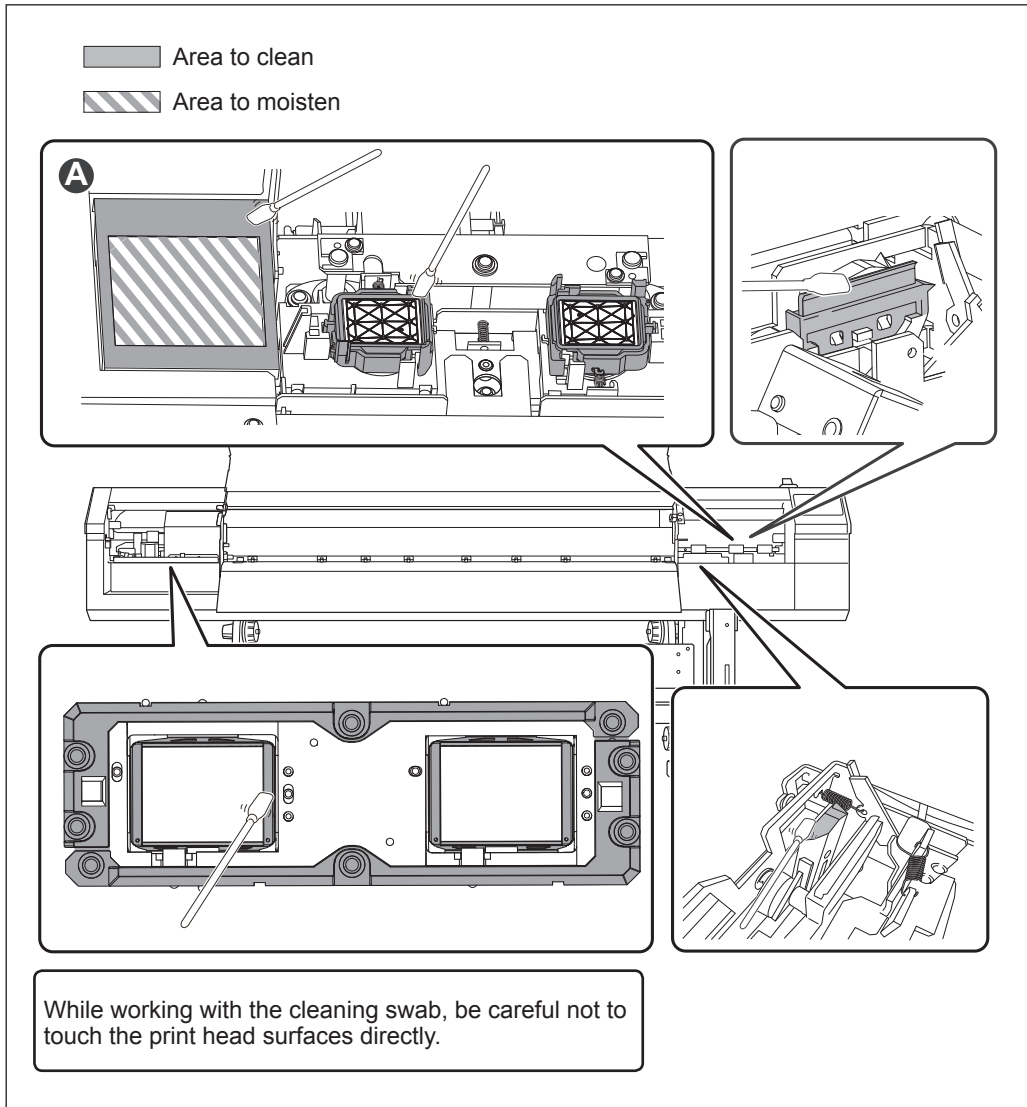

### 3. Reattach cover L, cover R, and quit the manual cleaning menu.

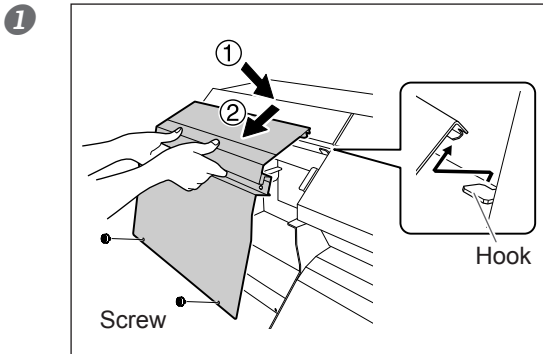

**Attach the cover L.**

Lower the cover L in the direction of ①, engage it with the hook, and then lower it in the direction of ②. Finally secure it with the screws.

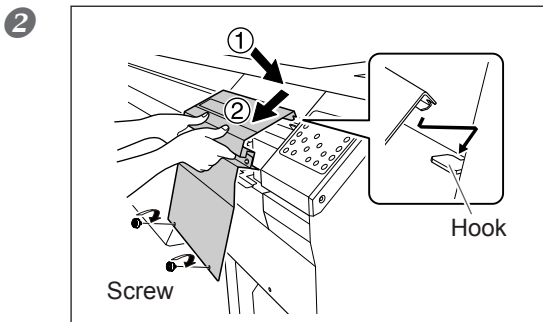

**Attach the cover R.**

Lower the cover R in the direction of ①, engage it with the hook, and then lower it in the direction of ②. Finally secure it with the screws.

**3 Press **ENTER**.**

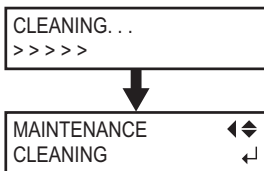

The screen shown in the figure appears and cleaning starts.

When it finishes, the screen shown in the figure appears again.

**4 Press **MENU** and **Left Arrow** in this order to go back to the original screen.**

### 4. Perform a printing test to verify the results of the procedure.

**Perform a printing test to check the results.**

Perform cleaning using the machine's cleaning feature several times when necessary.

☞ P. 61, "Manual Cleaning of Print Heads"

# When Problems Such As Dot Drop-out are Not Cleared Up

## When Problems Such As Dot Drop-out are Not Cleared Up

When flaws in the dot pattern such as dot drop-out are not cleared up even after performing cleaning using the cleaning function (normal, medium, or powerful) or manual cleaning, perform the operation described below.

### IMPORTANT!

A large amount of ink will be discharged during this operation. Perform this operation only when dot drop-out cannot be cleared up even after performing cleaning using the cleaning function (normal, medium, or powerful) or manual cleaning.

☞ P. 55, "Maintenance that Should Be Performed Daily"

☞ P. 59, "When Normal Cleaning Is Not Effective"

☞ P. 61, "Manual Cleaning of Print Heads"

### Procedure

#### 1 Discard the discharged fluid in the drain bottle.

By referring to P. 55, "Disposing of Discharged Fluid", dispose of the discharged fluid. Start from step 2.

### CAUTION

**Be sure to discard the discharged fluid at this step.**

A large amount of ink will be discharged during this operation. Be sure to discard the discharged fluid at this step. If you do not discard the discharged fluid at this step, the discharged fluid might overflow from the drain bottle during the subsequent process.

#### 2 Press **ENTER**.



Press **▼** several times until the screen shown on the left appears.

Press **▶**.

Press **▲** twice.



Press **▶**.

Press **▲** three times.



Press **▶**.



Check that the drain bottle is empty and press **ENTER**.



The screen shown in the figure appears.



When it finishes, the screen shown in the figure appears again.

#### 7 Press **MENU** **◀** in this order to go back to the original screen.

**POINT!** **Cleaning of the head surface as an emergency measure**

When dot drop-out and/or dot deflection is not improved even if cleaning is performed several times, you can clean the head surface as an emergency measure. Since the head surface (nozzle surface) has an extremely delicate mechanism, make sure to perform the operation carefully and deliberately. Note that this operation is an emergency measure. It may damage defect-free parts depending on the symptom, deteriorating it. If you have any questions, contact your authorized Roland DG Corp. dealer.

**Procedure**

- 1** **Moisten the cleaning stick with the cleaning liquid.**
- 2** **Softly press the cleaning stick to the head surface (nozzle surface).**  
Press it gently and softly so that the head nozzle is permeated with the cleaning liquid.  
Never rub the stick on the surface and press it forcibly.

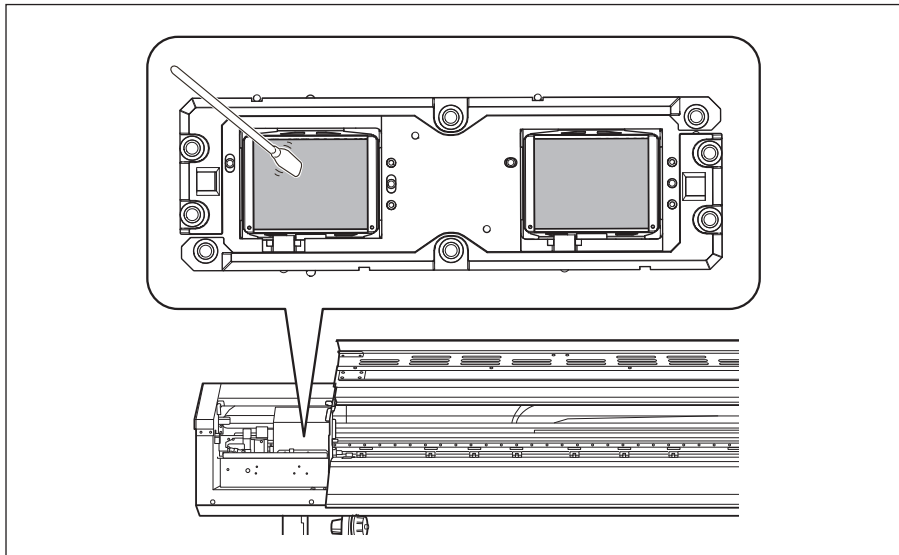

# Replacing Consumable Parts

## Replacing the Wiper

The wiper is a component that you use when cleaning the print heads. When the screen displays a message like the one shown, it means the item needs to be replaced. Replace with new items.



TIME FOR  
WIPER REPLACE

Regarding the purchase of the wiper, contact your authorized Roland DG Corp. dealer.

**⚠ CAUTION** Be sure to perform operations as specified by the following instructions, and never touch any area not specified in the instructions. Sudden movement of the machine may cause injury.

### 1. Display the [REPLACE WIPER] menu.

1  When the message shown in the figure appears, press **ENTER**.

2 Remove any media from the platen.

3 Press **MENU**.

4  Press **▼** several times until the screen shown on the left appears. Press **▶**, and then **▲**.

5  Press **▶**, and then **▼**.

6  Press **ENTER**.



NOW PROCESSING..

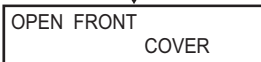

OPEN FRONT  
COVER

The print-head carriage moves to a location where wiper replacement is possible, and then the screen shown in the figure appears.

7 Open the front cover.

**8** OPEN COVER R

When the screen shown on the left appears, open the cover R.

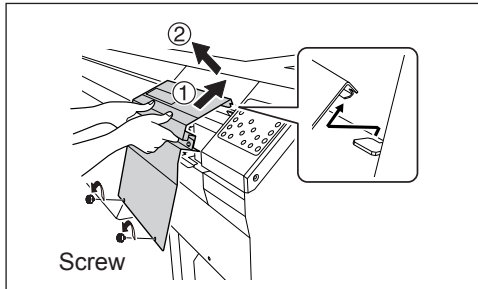

Remove the screws, lift the cover R in the direction of ①, and then pull it out in the direction of ②.

FINISHED?

Preparations are complete when this screen appears.

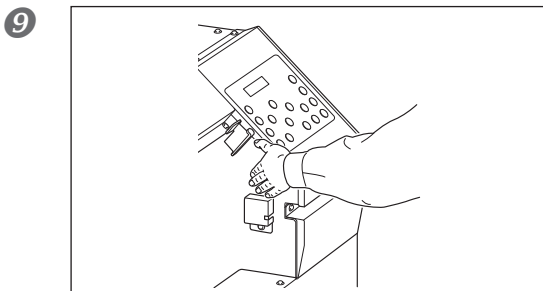

Touch the location shown in the figure to discharge any static electricity.

## 2. Replace the wiper.

**1** Detach the old wiper.

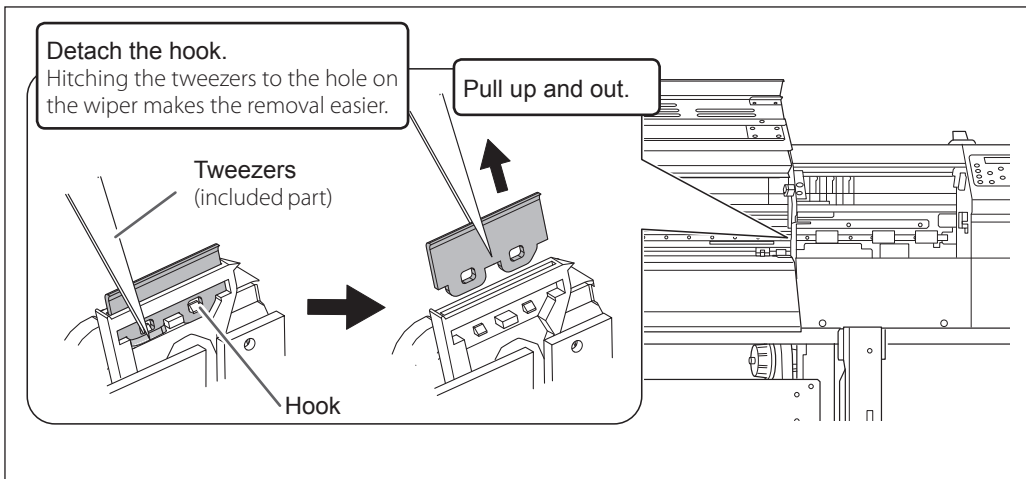

**2 Insert the new wiper.**

Place the inclined end on the back side. If the wiper is placed inversely, the proper cleaning becomes impossible.

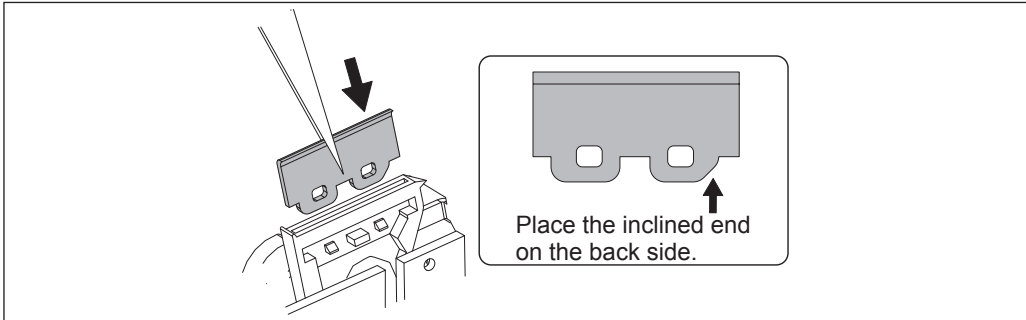

**3**

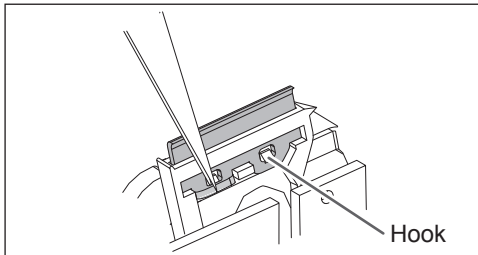

**Attach the hook.**

Make sure to attach the hook. Otherwise it cases dot-drop out or else.

**3. Quit the wiper replacement menu.**

**1 Attach the cover R.**

**2 Close the front cover.**

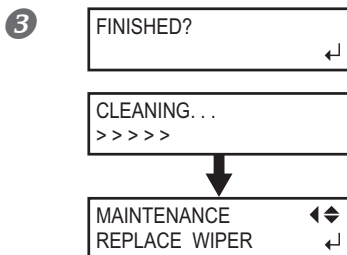

Press **ENTER**.

After the process to quit the wiper replacement menu, the screen shown in the figure appears.

**4 Press **MENU** and **Left Arrow** in this order to go back to the original screen.**

**4. Perform a printing test to verify the results of the procedure.**

**Perform a printing test to check the result.**

☞ P. 61, "Manual Cleaning of Print Heads"



## Replacing the Felt Wiper

TIME FOR  
FELT REPLACE ↵

The felt wiper is the part used for cleaning of the print heads. When such the screen is displayed on the display screen, it is the time for replacement. Replace it with a new item.

Regarding the purchase of the felt wiper, contact your authorized Roland DG Corp. dealer.

### ⚠ CAUTION

Be sure to perform operations as specified by these instructions, and never touch any area not specified in the instructions. Sudden movement of the machine may cause injury.

### 1. Enter the felt wiper replacement menu.

① 

When the message shown in the figure appears, press .

② Remove any media.

③ Press .

④ 

Press  several times until the screen shown on the left appears.

Press , and then .

⑤ 

Press .

Press  twice.

⑥ 

Press .

NOW PROCESSING . .



OPEN FRONT  
COVER

The print-head carriage moves to a location where felt wiper replacement is possible, and then the screen shown in the figure appears.

7 Open the front cover.



When the screen shown on the left appears, open the cover R.

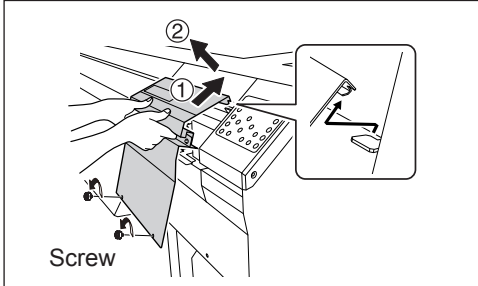

Remove the screws, lift the cover R in the direction of ①, and then pull it out in the direction of ②.

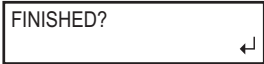

Preparations are complete when this screen appears.

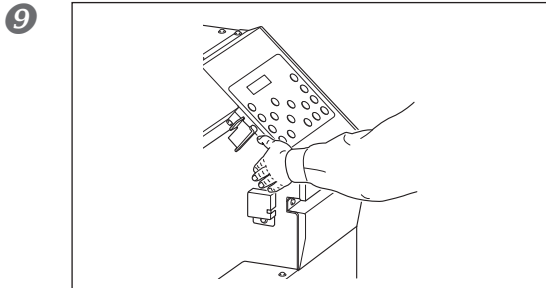

Touch the location shown in the figure to discharge any static electricity.

## 2. Replace the felt wiper.

1 Detach the old felt wiper.

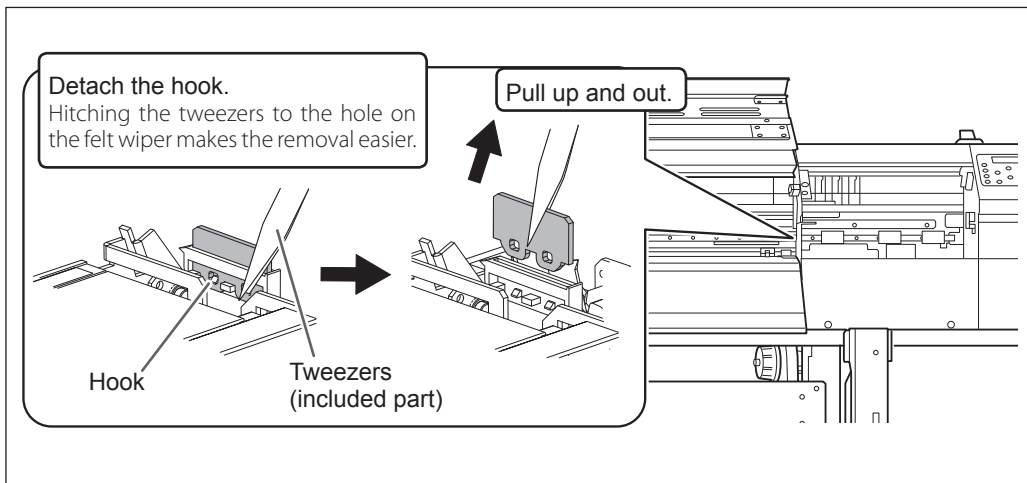

2

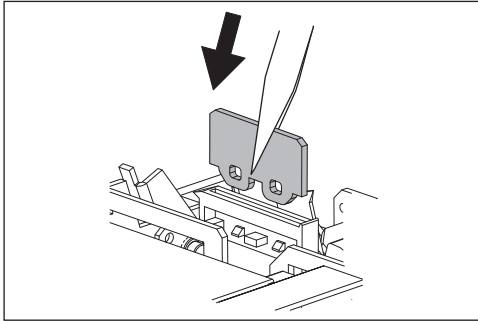

Insert the new felt wiper.

3

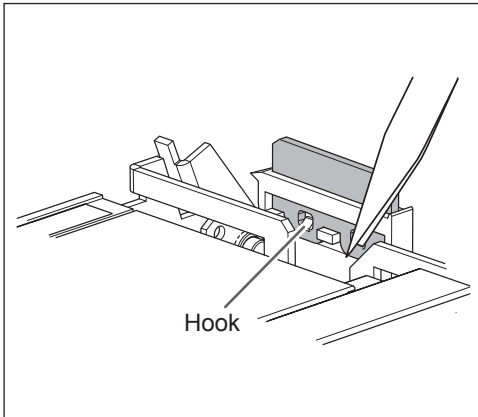

**Attach the Hook.**

Make sure to attach the hook. Otherwise it cases dot-drop out or else.

### 3. Quit the felt wiper replacement menu.

1 Attach the cover R.

2 Close the front cover.

3

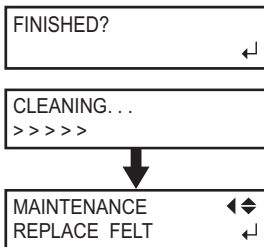

Press **ENTER** .

After the process to quit the felt wiper replacement menu, the screen shown in the figure appears.

4

Press **MENU** **←** in this order to go back to the original screen.

### 4. Perform a printing test to verify the results of the procedure.

**Perform a printing test to check the result.**

☞ P. 61, "Manual Cleaning of Print Heads"

## Replacing the Blade

If the blade becomes dull, or if the edge of the blade is chipped, or if the blade quality is lowered, replace it with a new blade.

**⚠ CAUTION** Be sure to perform operations as specified by these instructions, and never touch any area not specified in the instructions. Sudden movement of the machine may cause injury.

**⚠ CAUTION** Never touch the tip of the blade with your fingers. Doing so may result in injury.

### 1. Enter the blade replacement menu.

1 Press **MENU**.

2 

|          |    |
|----------|----|
| MENU     | ◀▶ |
| SUB MENU | ▶  |

Press **▼** several times to display the screen shown on the left.

Press **▶**, and then **▲**.

3 

|             |    |
|-------------|----|
| SUB MENU    | ◀▶ |
| MAINTENANCE | ▶  |

Press **▶**.

4 

|               |    |
|---------------|----|
| MAINTENANCE   | ◀▶ |
| REPLACE KNIFE | ↵  |

Press **▼** several times to display the screen shown on the left.

Press **ENTER**.

5 

|                  |
|------------------|
| NOW PROCESSING.. |
|------------------|

The cutting carriage moves to a location permitting blade replacement, and then the screen shown in the figure appears.

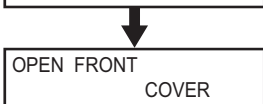

6 Open the front cover.

|           |   |
|-----------|---|
| FINISHED? | ↵ |
|-----------|---|

Preparations are complete when this screen appears.

### 2. Replace the blade.

1

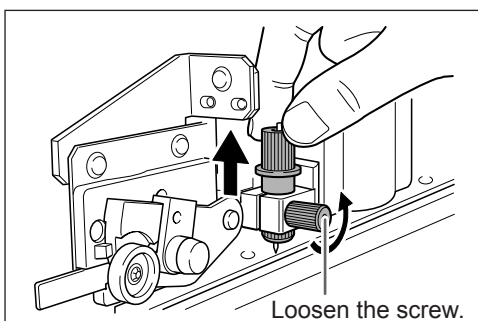

Remove the blade holder.

**2 Replace the blade.**

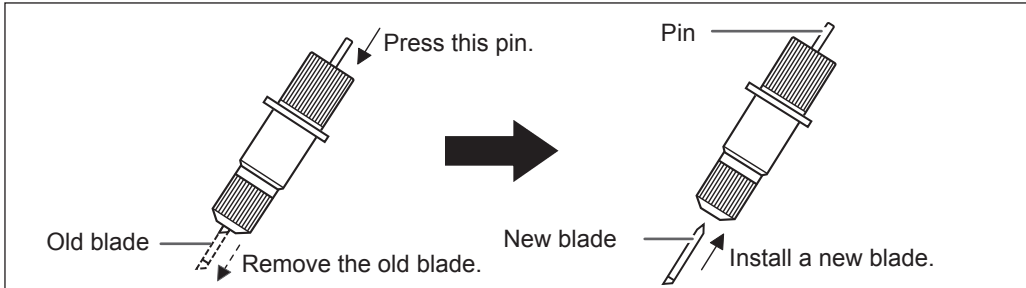

**3**

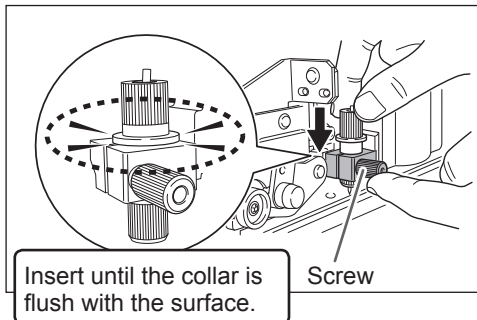

**Support the screw from below and insert the blade holder**

If installed without supporting the screw in this way, cutting quality may become poor.

**4**

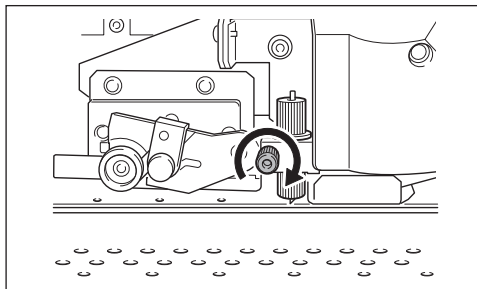

**Tighten the screw.**

Tug the blade holder upward to make sure it does not come loose.

**3. Quit the blade replacement menu.**

**1 Close the front cover.**

Press **ENTER**.

**2 Press **MENU** **←** in this order to go back to the original screen.**

**4. Adjusting the Cutting Conditions and Cutting-in Amount.**

☞ P. 101, "Fine-tuning the Cutting Conditions"

☞ P. 68, "Replacing the Wiper"

## Replacing the Separating Knife

If the separating knife becomes dull, replace it with the included replacement knife.

**⚠ CAUTION** Be sure to perform operations as specified by these instructions, and never touch any area not specified in the instructions. Sudden movement of the machine may cause injury.

**⚠ CAUTION** Never touch the tip of the separating knife with your fingers. Doing so may result in injury.

### 1. Replacing the Separating Knife

1 Remove any media.

2 Press **MENU**.

3 

Press **▼** several times to display the screen shown on the left. Press **▶**, and then **▲**.

4 

Press **▶**.

5 

Press **▼** several times to display the screen shown on the left. Press **ENTER**.



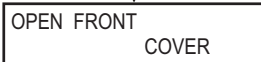

The cutting carriage moves to a location where blade replacement possible, and then the screen shown in the figure appears.

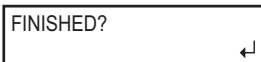
6 

**Open the front cover.** Preparations are complete when this screen appears.

### 2. Replace the separating knife

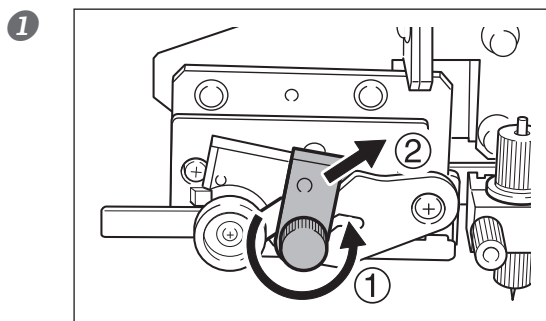

**Remove the separating knife.**

- ① Loosen the screw until it slips out.
- ② Grasp the screw portion, and slowly pull it out in the direction of the arrow. When doing this, do not pull it back toward you.

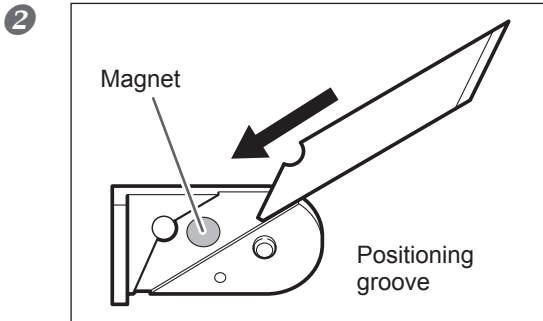

**Install a new knife.**

The knife is secured in place by the magnet.

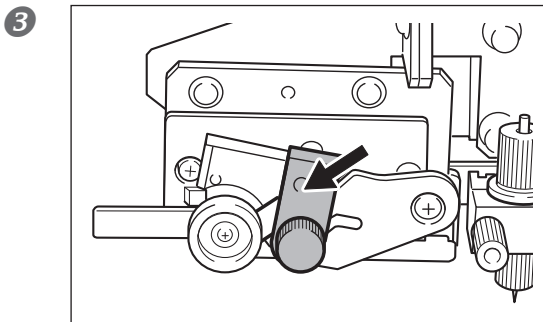

**Slowly insert it into the groove.**

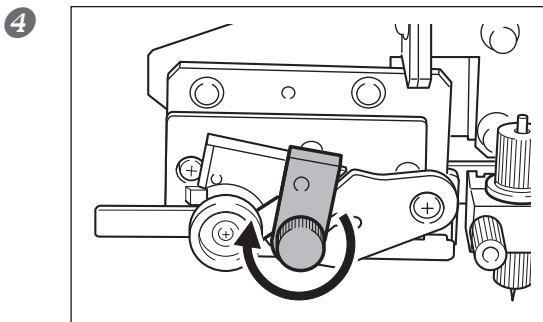

**Tighten the screw.**

Take care to ensure that the knife does not slip out of position at this time.

**3. Quit the blade replacement menu.**

1 **Close the front cover.**  
Press **ENTER**.

2 Press **MENU** **←** in this order to go back to the original screen.

# When Not in Use for a Prolonged Period

## Keep Performing Maintenance

### Switch On the Power Once a Month

Switch on the sub power once a month. When you turn on the power, the machine automatically performs some operations such as those to keep the print heads from drying out. Allowing the machine to stand completely unused for a prolonged period may damage the print heads, so be sure to switch on the power to perform these automatic operations.

### Keep at a Constant Temperature and Relative Humidity

Even when the machine is not in use, keep it at a temperature of 5 to 40°C (41 to 104°F) and a relative humidity of 20 to 80% (with no condensation). Temperatures that are too high may degrade the ink and cause malfunction. Temperatures that are too low may cause the ink to freeze and damage the heads.

## Alarm Feature

PRESS THE POWER  
KEY TO CLEAN

This feature is to remind you to switch on the sub power once a month. When the machine remains unused for about one month, this screen appears and a warning beep sounds. If this screen appears, switch on the sub power. When maintenance operations finish, switch off the sub power.

This feature operates when the printer's main power is turned on. Be sure to always switch on the printer's main power even if the printer is not used for a prolonged period.

## When Not in Use for a Prolonged Period, Precaution 1

***In advance, insert ink cartridges that have a large amount of ink remaining.***

If the ink runs out, the machine will not be able to periodically perform automatic maintenance. If the machine is left in this state, the print heads may malfunction. If you know that you will not use the machine for a prolonged period, insert ink cartridges that have a large amount of ink remaining.

## When Not in Use for a Prolonged Period, Precaution 2

***Discard the discharged fluid in advance of prolonged periods of disuse.***

If you know that you will not use the machine for a prolonged period, follow the procedure below to discard the discharged fluid.

### Procedure

1 Press **MENU**.



2 

Press **▼** several times to display the screen shown on the left.

Press **▶**, then **▲**.



3 SUB MENU  
MAINTENANCE

Press , then .

4 MAINTENANCE  
DRAIN BOTTLE

Press .

5 EMPTY  
DRAIN BOTTLE

When the screen on the left is displayed, remove the drain bottle and discard the discharged fluid.

**CAUTION**

Before you detach the drain bottle, be sure to wait for the screen to display "EMPTY DRAIN BOTTLE."

Failing to do so may cause discharged fluid to flow out of the machine and spill onto your hands or the floor and cause a stain.

6 EMPTY  
DRAIN BOTTLE

Attach the emptied drain bottle to the machine once more.

Press .

7 RESET DRAIN  
COUNTER

Press .

8 MAINTENANCE  
DRAIN BOTTLE

Press  to go back to the original screen.

**WARNING**

Never place discharged fluid or ink near an open flame.

Doing so may cause a fire.

**CAUTION**

To store discharged fluid temporarily, place it in the included drain bottle or in a durable sealed container such as a metal can or polyethylene tank, and cap the container tightly.

Any spillage or vapor leakage may cause a fire, an odor, or physical distress.

***Store discharged fluid in a location not exposed to direct sunlight.***

When temporarily storing discharged fluid in the included drain bottle, keep the drain bottle out of direct sunlight. Otherwise the discharged fluid may harden, the waste bottle may become unusable, or the waste bottle may be deteriorated, the discharged fluid may leak.

***Dispose of discharged fluid properly, in accordance with the laws in effect in your locale.***

Discharged fluid is flammable and contains toxic ingredients. Never attempt to incinerate discharged fluid or discard it with ordinary trash. Also, do not dispose of it in sewer systems, rivers, or streams. Doing so may have an adverse impact on the environment.

# Special Maintenance

## Draining Ink and Performing Internal Washing

### Procedure

- 1 Press **MENU**.
- 2 

|          |    |
|----------|----|
| MENU     | ◀▶ |
| SUB MENU | ▶  |

 Press **▼** several times until the screen shown on the left appears.  
Press **▶**.  
Press **▲** twice.
- 3 

|             |    |
|-------------|----|
| SUB MENU    | ◀▶ |
| INK CONTROL | ▶  |

 Press **▶**.  
Press **▼** twice.
- 4 

|             |    |
|-------------|----|
| INK CONTROL | ◀▶ |
| HEAD WASH   | ↵  |

 Press **ENTER** to execute.

### Description

This drains the ink inside the printer and washes the interior using cleaning cartridges as a preliminary for moving the printer or conducting maintenance. This operation requires eight unused SOL INK cleaning cartridges and six dummy cartridges. The screen displays information such as instructions to insert and remove cartridges. Follow these instructions to carry out the procedure. After finishing washing, the sub power is automatically switched off.

You do not need to carry this out as part of your daily maintenance activities.

## Draining Ink Remaining Inside the Machine

### Procedure

- 1 Press **MENU**.
- 2 

|          |    |
|----------|----|
| MENU     | ◀▶ |
| SUB MENU | ▶  |

 Press **▼** several times until the screen shown on the left appears.  
Press **▶**.
- 3 

|             |    |
|-------------|----|
| SUB MENU    | ◀▶ |
| INK CONTROL | ▶  |

 Press **▼** several times until the screen shown on the left appears.  
Press **▶**, and then **▼**.
- 4 

|             |    |
|-------------|----|
| INK CONTROL | ◀▶ |
| PUMP UP     | ↵  |

 Press **ENTER** to execute.

### Description

This removes ink inside the printer as a preliminary procedure for performing maintenance. This operation requires six dummy cartridges. The screen displays information such as instructions to insert and remove cartridges. Follow these instructions to carry out the procedure. After finishing the procedure, the sub power is automatically switched off. You do not need to carry this out as part of your daily maintenance activities.

# Chapter 4

## Part of Practice

|  |     |
|--|-----|
| Fully Utilizing Preset Function.....   | 82  |
| Saving Various Settings as a Name Assigned Preset .....  | 82  |
| Loading a Saved Preset .....   | 83  |
| Automatic loading of a saved preset when media is loaded.....  | 84  |
| Fully Utilize the Media Heating System .....   | 85  |
| What Is the Media Heating System? .....  | 85  |
| Making the Temperature Setting for the Media Heating System ..   | 86  |
| Control of Media Heating System during Preheating .....  | 88  |
| Drying the Trailing Edge of the Printing Area on the Dryer.....  | 88  |
| Setting the Drying Time after Printing .....   | 89  |
| Using an Optional Dryer .....  | 90  |
| Using a Blower-fan Unit.....   | 90  |
| Fully Utilizing the Correction Function .....  | 91  |
| Correcting for Misalignment in Bidirectional Printing .....  | 91  |
| Correcting for Misalignment in Bidirectional Printing More Precisely ..                                  | 92  |
| Alleviating Horizontal Bands and the Like (feed correction function) ..                                  | 92  |
| Accommodating to the Types and Condition of Media.....   | 94  |
| Adjusting Head Height to Match Media Thickness .....   | 94  |
| Using Transparent Media .....  | 95  |
| Printing Hard-to-dry Media .....   | 95  |
| Using the Media Easy to be Winkled/Hard to be Fed.....   | 96  |
| Speeding Up Output for Narrow Media .....  | 97  |
| Preventing Soiling of the Media and Dot Drop-out .....   | 98  |
| Using Sticky Media .....   | 99  |
| Fully Utilizing Cutting Function.....  | 100 |
| Hints and Tips for Cutting Setting .....   | 100 |
| Preventing Pulling of the Media with Undue Force When Performing Cutting Only ...                        | 100 |
| Fine-tuning the Cutting Conditions .....   | 101 |
| Accurately Adjusting the Cutting-in Amount.....  | 103 |
| Performing Distance Correction During Cutting .....  | 104 |
| Correcting Misalignment of the Printing and Cutting Positions ..   | 105 |
| Prioritize The Cuttings Settings of This Machine to The Settings of a Computer Side in Software RIP..... | 107 |
| Viewing the Automatic Environment Correction Function Settings ..  | 108 |
| Performing Printing and Cutting Separately.....  | 109 |
| To Perform Printing and Cutting Separately .....   | 109 |
| Printing with Crop Marks .....   | 109 |
| Aligning Automatically and Cutting .....   | 111 |
| Aligning Manually and Cutting .....  | 113 |
| Correcting Misalignment for Printing and Cutting Position When Using Crop Marks.....                     | 114 |
| Using Media Take-up System .....   | 117 |
| Features of the Take-up System.....  | 117 |
| What to Select at the Time of Media Setup .....  | 117 |
| Operating Conditions for the Take-up System.....   | 117 |
| About the Paper Tube.....  | 118 |
| How to Take Up Media .....   | 118 |
| How to Remove Taken-up Media .....   | 123 |

# Fully Utilizing Preset Function

## Saving Various Settings as a Name Assigned Preset

### Procedure

1 Press **MENU**.

2 

|        |    |
|--------|----|
| MENU   | ◀▶ |
| PRESET | ▶  |

Press **▼** to display the left figure.  
Press **▶**, and then **▼**.

3 

|        |    |
|--------|----|
| PRESET | ◀▶ |
| SAVE   | ▶  |

Press **▶**.

4 

|       |    |
|-------|----|
| SAVE  | ◀▶ |
| NAME1 | ↵  |

Press **▲** **▼** to select one of NAME1 through 8.  
Press **ENTER** to enable the setting.

The present menu settings are saved.

5 

|          |     |
|----------|-----|
| SET NAME | ◀▶▶ |
| S_       | ↵   |

Press **▲** **▼** to enter a character.  
When a character is decided, press **▶**.

The characters you can enter are "A" through "Z," "0" through "9," and the "-" character. You can enter up to 15 characters, including spaces.

6 

|          |     |
|----------|-----|
| SET NAME | ◀▶▶ |
| SAMPLE_  | ↵   |

Press **▲** **▼** to enter a character.

Enter the following characters in the same way.

When entries are completed, press **ENTER** to enable the setting.

7 Press **MENU** **◀** in this order to go back to the original screen.

### Description

Using the [PRESET] menu lets you easily change a wide variety of settings to optimize them for the media. Up to eight types of presets can be saved. You can assign a name to each one. Using media names for these may aid recognition and clarity. Making changes for each menu item every time you change the media can be troublesome. That's why it can be useful to save the menu-item settings optimized for an often-used type of media as a preset. The next time you use the media, you can change the menu-item settings to the optimal values for the media simply by loading the preset you saved. Menu items that can be saved in presets are listed below.

|  |   |
|--|---|
| [PRE] (Preheater), [PRINT] (Print heater), [DRYER] | ☞ P. 86, "Making the Temperature Setting for the Media Heating System"                      |
| [PREHEATING]                                       | ☞ P. 88, "Control of Media Heating System during Preheating"                                |
| [DRYING TIME]                                      | ☞ P. 89, "Setting the Drying Time after Printing"   |
| [ADJUST BI-DIR SIMPLE SETTING]                     | ☞ P. 91, "Correcting for Misalignment in Bidirectional Printing"                            |
| [ADJUST BI-DIR DETAIL SETTING]                     | ☞ P. 92, "Correcting for Misalignment in Bidirectional Printing More Precisely"             |
| [CALIBRATION]                                      | ☞ P. 92, "Alleviating Horizontal Bands and the Like (feed correction function)"             |
| [EDGE DETECTION]                                   | ☞ P. 95, "Using Transparent Media"  |
| [SCAN INTERVAL]                                    | ☞ P. 95, "Printing Hard-to-dry Media"   |
| [VACUUM POWER]                                     | ☞ P. 96, "Using the Media Easy to be Winkled/Hard to be Fed"                                |
| [FULL WIDTH S]                                     | ☞ P. 97, "Speeding Up Output for Narrow Media"  |
| [FEED FOR DRY]                                     | ☞ P. 88, "Drying the Trailing Edge of the Printing Area on the Dryer"                       |
| [FORCE], [SPEED], [OFFSET], [UP-SPEED]             | ☞ P. 101, "Fine-tuning the Cutting Conditions"  |
| [CALIBRATION] (in the [CUTTING MENU])              | ☞ P. 104, "Performing Distance Correction During Cutting"                                   |
| [PRINT-CUT ADJ.]                                   | ☞ P. 105, "Correcting Misalignment of the Printing and Cutting Positions"                   |
| [CROP-CUT ADJ.]                                    | ☞ P. 114, "Correcting Misalignment for Printing and Cutting Position When Using Crop Marks" |
| [BROWER FAN]                                       | ☞ P. 90, "Using a Blower-fan Unit"  |
| [MEDIA RELEASE]                                    | ☞ P. 99, "Using Sticky Media"   |

☞ P. 83, "Loading a Saved Preset"

## Loading a Saved Preset

### Procedure

1 Press .

2 

Press  to display the left figure.  
Press  twice.

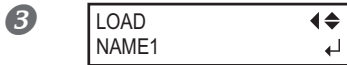

Press ▲ ▼ to select a name to be called.  
Press ENTER to enable the setting.



The settings are changed and the screen shown in the figure appears.

### Description

This loads a saved preset. You can select any one of eight types of presets. (When no names have been assigned, you select from among NAME1 through NAME8.) If you load a preset while SET UP is illuminated, SET UP goes dark. If this happens, raise the loading lever, make sure the media is loaded straight, then lower the loading lever again to make output possible. .

## Automatic loading of a saved preset when media is loaded

### Procedure

1 Press MENU .



Press ▼ to display the left figure.  
Press ▶, and then ▲ .



Press ▶ .



Press ▲ ▼ to select "ENABLE."  
Press ENTER to enable the setting.

5 Press ENTER ◀ in this order to go back to the original screen.

### Description

Once "ENABLE" is selected, the screen for loading a preset is always displayed when the media is loaded. Follow the procedure given below to use the loaded preset.

### How to use the loaded preset

When you press SET UP at the end of the media loading process, the screen shown in the figure appears. When you press ENTER, the preset displayed in the screen is loaded. (Pressing SET UP before pressing ENTER performs setup with current settings without loading the preset.)



The preset displayed in the screen is either the last loaded preset or last saved preset. You can select other presets by pressing ▲ and ▼ .

# Fully Utilize the Media Heating System

## What Is the Media Heating System?

This machine is equipped with a media heating system that warms the media. You use this mainly to improve ink adhesion and also dry the ink. You can adjust the temperature settings to match the type of media and the printing speed.

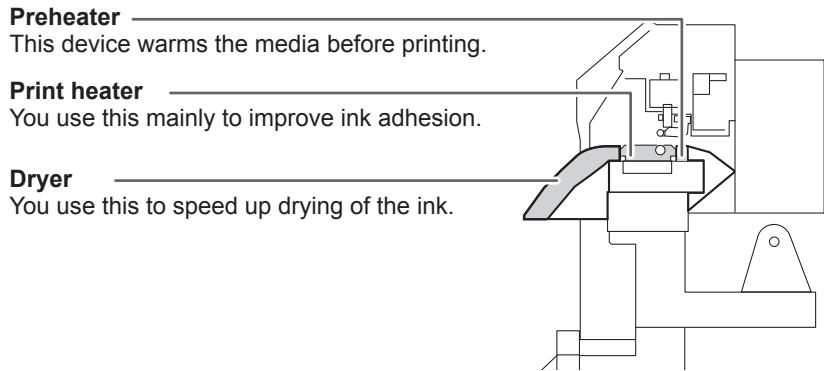

\* By using an optional dryer, you can speed up drying of the ink more.

☞ P. 90, "Using an Optional Dryer"

### **⚠ WARNING**

#### **CAUTION: high temperatures**

The platen and dryer become hot. Exercise caution to avoid fire or burns.

### **⚠ WARNING**

#### **Remove any loaded media or switch off the sub power when printing is not being performed.**

The continued application of heat at a single location may cause fire or produce toxic gases.

### **⚠ WARNING**

#### **Never use media that cannot withstand the heat.**

Doing so may result in fire or the release of toxic gases, or may degrade the media.

### **⚠ WARNING**

#### **Never use the platen or dryer for any purpose for which they are not intended, such as to dry clothing.**

Doing so may cause overheating, resulting in fire or accident.

***Use at an ambient temperature of 20 to 32°C (68 to 90°F).***

If the machine is used at an ambient temperature lower than 20°C (68°F), then depending on the type or width of the media, wrinkling or temperature-caused unevenness may occur. If this happens, try lowering the temperature of the media heating system by about 2°C. To obtain stable printing results, however, the machine should be used at an ambient temperature of 20 to 32°C (68 to 90°F).

## Making the Temperature Setting for the Media Heating System

### Procedure

1 Press **HEATER CONFIG**.

2 

|     |    |       |    |
|-----|----|-------|----|
| PRE | 35 | PRINT | 35 |
| DRY | 50 |       |    |

The present temperature is displayed.

Press **HEATER CONFIG** a second time.

3 

|       |     |     |
|-------|-----|-----|
| DRYER | 50  | ◀▶  |
|       | 50▶ | 50◀ |

Press **◀ ▶** to select the unit.

4 

|       |     |     |
|-------|-----|-----|
| DRYER | 50  | ▲▼  |
|       | 50▶ | 55◀ |

Press **▲ ▼** to select a temperature.

You can set to "OFF."

Press **ENTER** to enable the setting.

5 Press **MENU** **◀** in this order to go back to the original screen.

### Estimate and hint of temperature setting

The optimal temperature for the media heating system varies according to such factors as the type of media and differences in the print mode. Use the following as a general guide and adjust accordingly.

|  |   |
|--|---|
| <b>Preheater</b>   | Set this to a temperature that is the same as or lower than the temperature of the print heater. You use the preheater mainly to heat media gradually. This is because media becomes more likely to shrink or wrinkle if heated suddenly.   |
| <b>Print heater</b>  | You use this mainly to improve ink adhesion and inhibit smudging. If the ink forms lumps or smudges, raise the temperature. Note, however, that a temperature that is too high may degrade the media or cause it to wrinkle.  |
| <b>Dryer</b>   | When ink drying is poor, raise the temperature. Note, however, that a temperature that is too high may degrade the media or cause it to wrinkle.  |
| <b>The relationship between the print mode and temperature</b> | The optimal temperature for the media heating system varies according to such factors as the type of media and differences in the print mode. If smudging or poor drying occur even after raising the temperature, try using a print mode of software RIP offering higher image quality. Conversely, when you want to use a faster print mode, raise the temperature. |
| <b>Amount of ink</b>   | When you change the amount of ink using the settings for your software RIP, adjusting this may yield better results. If problems such as smudging persist even after raising the temperature, try reducing the amount of ink.   |
| <b>Other points to remember</b>                                | When recommended settings for temperature, print mode, and other values are given as the use condition of your media, use the suggested settings.   |



---

## Examples of Preset Temperatures

---

| Media   | Temperature  |
|---|--|
| Type: Scrim banner (PVC)<br>Thickness: 300 to 400 $\mu\text{m}$ (12 to 16 mil)  | Preheater: 40°C (104°F)<br>Print heater: 40°C (104°F)<br>Dryer: 50°C (122°F) |
| Type: Marking film (PVC, with adhesive)<br>Thickness: 60 to 100 $\mu\text{m}$ (2.5 to 4 mil, not including backing paper) | Preheater: 40°C (104°F)<br>Print heater: 40°C (104°F)<br>Dryer: 50°C (122°F) |

- These are only rough estimates. Make adjustments to match the media you're using.
- Using the media heating system does not necessarily make it possible to apply ink to every kind of media. Be sure to test in advance.
- Results may vary greatly depending on the print mode and other factors. Make settings suited to the media.
- When suggested settings for temperature, print mode, and other values are given, use the suggested settings.

---

## Description

---

By default setting, simply switching on the power does not make the media heating system warm up to the preset temperature. The temperature rises until preset temperature when the media is loaded correctly and **SET UP** lights up. You can also make this setting on the software RIP. When you have made the setting on the software RIP, the software RIP's setting is used.

- Depending on the usage environment, the temperature of the print heater or dryer may become higher than the preset temperature, but this does not represent a problem.

---

## Default Setting

---

[PRE]: 40°C (104°F)  
[PRINT]: 40°C (94°F)  
[DRY]: 50°C (122°F)

## Control of Media Heating System during Preheating

Note: Preheating: State that the main power and the sub power are switched on and **SET UP** is not lighted (state that media setup is not completed)

### Procedure

1 Hold down **MENU** and press **HEATER CONFIG**.

2  Press **▼** to display the screen shown on the left. Press **▶**.

3  Press **▲** **▼** to select setting.  
**MENU:** The system performs heating to the preset temperature at all times, without lowering the temperature during preheating.  
**30°C:** The system keeps 30°C during preheating.  
**OFF:** The system switches the media heating system off during preheating.  
 Press **ENTER** to enable the setting.

4 Press **MENU** **◀** in this order to go back to the original screen.

### Default Setting

[PREHEATING]: 30°C

## Drying the Trailing Edge of the Printing Area on the Dryer

### Procedure

1 Hold down **MENU** and press **HEATER CONFIG**.

2  Press **▶**.

3  Press **▲** **▼** to select "ENABLE."  
 Press **ENTER** to enable the setting.

4 Press **MENU** **◀** in this order to go back to the original screen.

---

## Description

---

- "ENABLE" : media feed is performed until the trailing edge of the printing area is positioned on the dryer. A margin from the print end position to the subsequent print start position is fixed at 200 mm. The margin set on the computer is ignored.
    - ☞ P. 90, "Using an Optional Dryer"
  - "DISABLE" : media feed stops simultaneously when printing ends. This means that the trailing edge of the printing area is not fed to the dryer unless you continue with a subsequent printing operation.
- 

## Default Setting



---

[FEED FOR DRY]: DISABLE

## Setting the Drying Time after Printing

### Procedure

---

- 1 Hold down **MENU** and press **HEATER CONFRG**.
- 2  Press **▲** to display the screen shown on the left.  
Press **▶**.
- 3  Press **▲** **▼** to select the interval.  
Press **ENTER** to enable the setting.
- 4 Press **MENU** **◀** in this order to go back to the original screen.

---

## Description

---

Set the interval after the 1st page is printed. The next operation is not started until the set time passes. **PAUSE** is lighting during the interval. When pressing **PAUSE** while **PAUSE** is lighting, the interval is finished and the next operation is started. When holding on **SET UP** while **PAUSE** is lighting, output is canceled. You can also make this setting on the software RIP. When you have made the setting on the software RIP, the software RIP's setting is used.

---



## Default Setting

---

[DRYING TIME]: 0 min

## Using an Optional Dryer

### Procedure

- 1 Hold down **MENU** and press **HEATER CONFIG**.
- 2  Press **▼** several times to display the screen shown on the left. Press **▶**.
- 3  Press **▲** **▼** to select "ENABLE". Press **ENTER** to enable the setting.
- 4 Press **MENU** **◀** in this order to go back to the original screen.

### Description

This switches the optional dryer "ENABLE" or "DISABLE".



When using an optional dryer, set [OPTION DRYER] to "ENABLE". And you can speed up drying of the ink more. Contact your authorized Roland DG Corp. dealer for recommended dryer models. For the details of how to use an optional dryer, refer to the documentation for the dryer you're using.

### Default Setting

[OPTION DRYER]: DISABLE

## Using a Blower-fan Unit

### Procedure

- 1 Hold down **MENU** and press **HEATER CONFIG**.
- 2  Press **▼** several times to display the screen shown on the left. Press **▶**.
- 3  Press **▲** **▼** to select "ENABLE". Press **ENTER** to enable the setting.
- 4 Press **MENU** **◀** in this order to go back to the original screen.

### Description

This switches the optional blower-fan unit "ENABLE" or "DISABLE".

When using a blower-fan unit, select "ENABLE". And you can speed up drying of the ink more.

Contact your authorized Roland DG Corp. dealer for recommended blower-fan unit models. For the details of how to use a blower-fan unit, refer to the documentation for the blower-fan unit you are using.

### Default Setting

[BLOWER FAN]: DISABLE

# Fully Utilizing the Correction Function

## Correcting for Misalignment in Bidirectional Printing

### Procedure

1 Press **MENU**.

2 

Press **▼** several times to display the screen shown on the left.

Press **▶**.

3 

Press **ENTER**.

A test pattern is printed.

When printing is completed, press **▼** **▶** in this order.

4 

Press **▲** **▼** to select a correction value.

Press **ENTER** to enable the setting.

### To decide a Correction Value

Choose the value that produces the least misalignment of 2 lines.

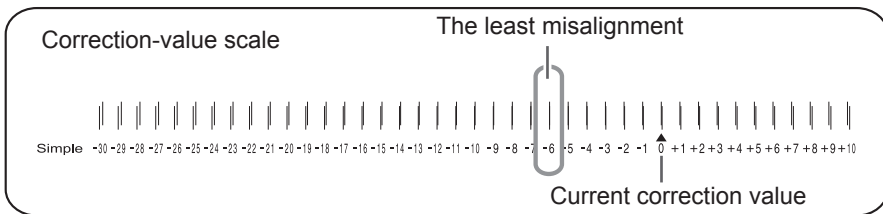

5 Press **MENU** **◀** in this order to go back to the original screen.

### Description

This machine prints by the bidirectional mode (in which the heads perform printing during both their outbound pass and return pass). This printing method is called "Bidirectional Printing." This method offers the advantage of being able to shorten output times, but subtle misalignment occurs during the outbound and return passes. The procedure to correct this and eliminate misalignment is "Bidirectional Correction." This misalignment varies according to the head height and the thickness of the media, so we recommend performing correction to match the media you're using.

This settings also serves to correct for misalignment of the printing and cutting positions. In such cases, check or adjust this setting.

☞ P. 105, "Correcting Misalignment of the Printing and Cutting Positions"



## Correcting for Misalignment in Bidirectional Printing More Precisely

When further correction is required, such as when adjustment made using [SIMPLE SETTING] does not enhance printing, use [DETAIL SETTING] to make corrections.

For information on operations, refer to P. 29, "Performing the Initial Adjustment (Correcting for Misalignment in Bidirectional Printing More Precisely)"

## Alleviating Horizontal Bands and the Like (feed correction function)

### Procedure

- 1 When the roll media is used, check that no sagging is found on the media.
- 2 Press **MENU**.
- 3  Press **▼** several times to display the screen shown on the left.  
Press **▶**.
- 4  Press **ENTER**.  
A test pattern is printed.  
When printing is completed, press **▼** **▶** in this order.
- 5  Press **▲** **▼** to select a correction value.  
Press **ENTER** to enable the setting.

### To decide a Correction Value

Select the value to make the upper/lower rectangular gap and overlap smallest.

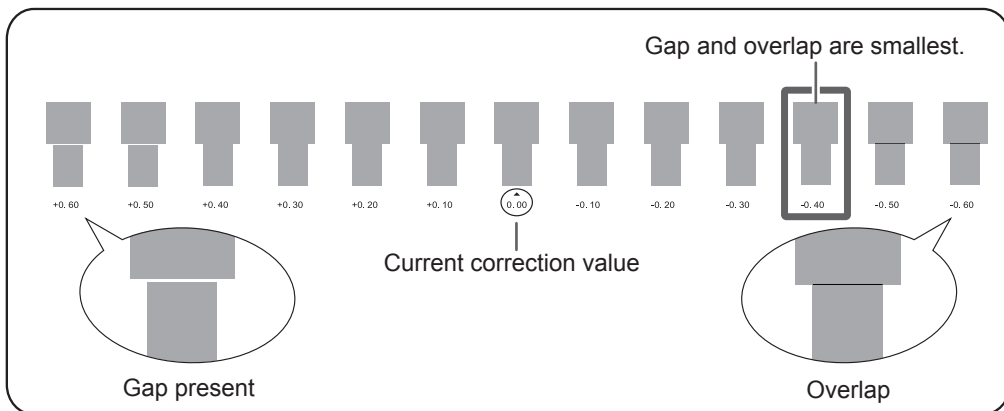

- 6 Press **MENU** **◀** in this order to go back to the original screen.

---

### Description

---

The movement distance of media experiences subtle changes due to the thickness of the media and the temperature of the media heating system. When the movement distance becomes discrepant, horizontal stripes are more likely to occur during printing. We recommend performing correction to match the media you're using and the media heating system. Repeat the process of printing a test pattern and entering a correction value several times to find the optimal value.

You can also make this setting on the software RIP computer (by, for example, choosing the media type in the software RIP you are using). When you have made the setting on the computer, the computer's setting is used and the printer's setting is ignored.

---

### Default Setting

---

[SETTING]: 0.00%

# Accommodating to the Types and Condition of Media

## Adjusting Head Height to Match Media Thickness

### Procedure

1 Press **MENU**.

2 

Press  several times to display the screen shown on the left.

Press .

3 

When the left figure is displayed, open the front cover.

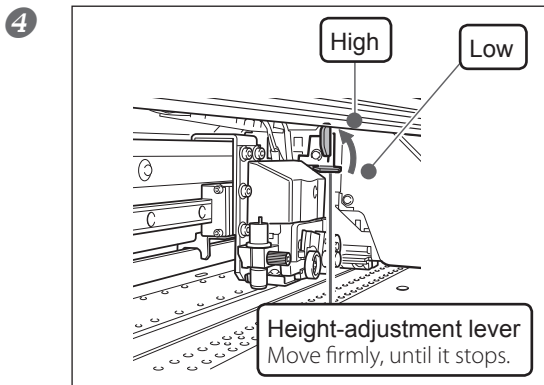

**Move the height-adjustment lever to adjust the head height.**

Moving the lever to "HIGH" makes a warning beep sound twice. Moving it to "LOW" makes the warning beep sound once.

5 

**Close the front cover.**

The print-head carriage moves to the original position, and then the screen shown in the figure appears.

6 Press **MENU**  in this order to go back to the original screen.

### Description

Depending on the media, media may wrinkle or come loose from the platen during printing, increasing the chance of contact with the print heads. When you are using such media, adjust the head height to "HIGH." Printing quality when the head height is set to "HIGH" may be coarser or otherwise lower than when set to "LOW." If this happens, refer to the pages indicated below.

- ☞ P. 29, "Performing the Initial Adjustment (Correcting for Misalignment in Bidirectional Printing More Precisely)"
- ☞ P. 91, "Correcting for Misalignment in Bidirectional Printing"
- ☞ P. 98, "Preventing Soiling of the Media and Dot Drop-out"



## Using Transparent Media

### Procedure

1 Press **MENU**.

2 

Press **▼** several times to display the screen shown on the left.

Press **▶** twice.

3 

Press **▲** **▼** to select "DISABLE."

Press **ENTER** to enable the setting.



The settings are changed and the screen shown in the figure appears.

### Description

This setting enables or disables detection of the leading and trailing edges of the media. It is normally set to "ENABLE." When transparent media is loaded, set it to "DISABLE."

When "DISABLE" is selected, "ROLL," "TU," and "TU2" are available in setting the media. At this time, set the margin from the leading edge of the media to the print start position to 75 mm or more.

When [EDGE DETECTION] is set to "DISABLE," printing operation does not stop when the media runs out. If media runs out while printing is in progress, immediately press **PAUSE** to quit printing. Otherwise, there is a chance that the platen or the like may become soiled by ink or that ink may get inside and damage the machine.

### Default Setting

[EDGE DETECTION]: ENABLE

## Printing Hard-to-dry Media

### Procedure

1 Press **MENU**.

2 

Press **▼** several times to display the screen shown on the left.

Press **▶**, and then **▼**.

3 

Press **▶**.

4 

Press **▲** **▼** to select a value.

Larger values produce progressively slower movement of the media, enabling you to extend the drying time accordingly.

Press **ENTER** to enable the setting.

5 Press **MENU** **◀** in this order to go back to the original screen.

**Description**

You use this when ink dries poorly even when the media heating system is used. You can also make this setting on the software RIP. When you have made the setting on the software RIP, the setting is used and the printer's setting is ignored.

**Default Setting**

[SCAN INTERVAL]: OFF

**Using the Media Easy to be Winkled/Hard to be Fed**

**Procedure**

1 Press **MENU**.



Press **▼** several times to display the screen shown on the left.

Press **▶**.

Press **▼** twice.



Press **▶**.



Press **▲** **▼** to select a value. 0 to 100%

A larger value produces a larger suction force. For the media easy to be loose due to warping or winking, increase of the suction force may help correct the problem. When the media is flimsy and cannot move smoothly, reduction of the suction force may correct such the problem.

**AUTO**

The suction force is automatically adjusted to the optimal level for the media width.

Press **ENTER** to enable the setting.

5 Press **MENU** **◀** in this order to go back to the original screen.

**Description**

The platen uses suction to grip the media and keep it stable. The suction force can be adjusted corresponding to the mature and condition of the media.

You can also make this setting on the software RIP. When you have made the setting on the software RIP, the RIP's setting is used and the printer's setting is ignored.

**Default Setting**

[VACUUM POWER]: AUTO

## Speeding Up Output for Narrow Media

### Procedure

1 Press **MENU**.

2 

|          |    |
|----------|----|
| MENU     | ◀▶ |
| SUB MENU | ▶  |

Press **▼** several times to display the screen shown on the left.

Press **▶**.

3 

|              |    |
|--------------|----|
| SUB MENU     | ◀▶ |
| FULL WIDTH S | ▶  |

Press **▼** several times to display the screen shown on the left.

Press **▶**.

4 

|              |         |
|--------------|---------|
| FULL WIDTH S | ◀▶      |
| FULL         | ▶ OFF ↵ |

Press **▲** **▼** to select an item.  
**SHEET**

"SHEET" matches the range of head movement to the width of the media.

#### OFF

"OFF" matches the range of head movement to the output data. Movement is limited to the minimum amount necessary, and this can be expected to yield the fastest output. Note, however, that because the speed of media movement is no longer constant, colors may be uneven.

#### FULL

This makes the speed of media movement constant at all times and produces the most stable printing result.

Press **ENTER** to enable the setting.

5 Press **MENU** **◀** in this order to go back to the original screen.

### Description

This shortens output time by reducing the width of head movement to the minimum necessary. This is effective when the width of the media or the output data is narrow.

### Default Setting

[FULL WIDTH S]: FULL

## Preventing Soiling of the Media and Dot Drop-out

### Procedure

1 Press **MENU**.

2 

Press **▼** several times to display the screen shown on the left.

Press **▶**.

3 

Press **▼** several times to display the screen shown on the left.

Press **▶**.

4 

Press **▲** **▼** to select an item.

**PAGE**

Automatic cleaning is performed every time before printing starts.

**10 to 990 min**

Automatic cleaning is performed when the cumulative printing time reaches the value you set here.

**NONE**

Automatic cleaning is not performed.

Press **ENTER** to enable the setting.

5 Press **MENU** **◀** in this order to go back to the original screen.

### Description

In the following cases, Ink tends to collect on the surface of the heads. Under some conditions, this ink may be transferred to the media or cause dot drop-out. Use this feature at such times.

- When you use media prone to buildup of static charge.
- When the ambient temperature is low.
- When the head height is set to "HIGH."



Selecting "PAGE" or a value from "10 min" to "990 min," the ink buildup is removed before or during printing while printing is performed. Note, however, that using "PAGE" or a value from "10 min" to "990 min," results in longer printing times.

### Default Setting

[PERIODIC CL.]: NONE

## Using Sticky Media

### Procedure

- 1 Press **MENU**.
- 2  Press **▼** several times to display the screen shown on the left.  
Press **▶**.
- 3  Press **▼** several times to display the screen shown on the left.  
Press **▶**.
- 4  Press **▲** **▼** to select "ENABLE."  
Press **ENTER** to enable the setting.
- 5 Press **MENU** **◀** in this order to go back to the original screen.

### Description

Some types of media may tend to stick to the platen. Starting printing with the media sticking to the platen may make normal media feed impossible and cause the media to jam. When you're using such media, set the [MEDIA RELEASE] menu item to "ENABLE." This peels off the media if sticking before starting printing. Note, however, that media feed may be unstable when printing is performed after executing this operation. Leave this menu item set to "DISABLE" unless you specifically need to change it.

### Default Setting

[MEDIA RELEASE]: DISABLE



# Fully Utilizing Cutting Function

## Hints and Tips for Cutting Setting

- **Setting the [PREFEED] menu item to “ENABLE” makes the machine automatically feed out media and take it up again before cutting. This makes it unnecessary to run out media to the rear of the machine before the operation.**
  - ☞ P. 100, "Preventing Pulling of the Media with Undue Force When Performing Cutting Only"
- **Switching off the media heating system and allowing the temperature to cool before performing cutting can yield results that are more stable.**
  - ☞ P. 86, "Making the Temperature Setting for the Media Heating System"
- **The tip of the blade holder cap may scrape, and soil or damage the printed surface. If this happens, increase the amount of blade extension.**
  - ☞ P. 103, "Accurately Adjusting the Cutting-in Amount"

## Preventing Pulling of the Media with Undue Force When Performing Cutting Only

### Procedure

- 1 Hold down **MENU** and press **CUT CONFIG**.
- 2  Press **▼** several times to display the screen shown on the left.  
Press **▶**.
- 3  Press **▲** **▼** to select “ENABLE.”  
Press **ENTER** to enable the setting.
- 4 Press **MENU** **◀** in this order to go back to the original screen.

### Description

This feeds out media according to the size of the data sent from the computer before performing cutting. This makes it unnecessary to turn the media flanges by hand to feed out media every time you perform cutting. Note, however, that this feeds out media even when you're performing printing only, so set it to "DISABLE" when not needed.

### Default Setting

[PREFEED]: DISABLE

## Fine-tuning the Cutting Conditions

### Procedure

#### 1 Performing the Cutting Test

☞ P. 46, "Setting The Cutting Test And The Blade Force" Procedure 1.

#### 2 When cutting of the test patterns is completed, press **CUT CONFIG**.

#### 3 Press to select the cutting condition you want to set.

For information on the evaluation method of cutting test, refer to the next page.

#### [Force]

This sets the force (pressure) of the blade. (Default Setting 50 gf)

#### [Speed]

This sets the speed of cutting. Default Setting: 30 cm/s)

#### [OFFSET]

This makes the blade-offset setting for the blade. Enter the listed offset value for the blade. (Default Setting: 0.250 mm)

#### [UP-SPEED]

This sets the blade's up speed during cutting (the speed at which the blade travels when it moves to the next cutting line after cutting one cutting line). If the media comes loose during no-load feed and the blade damages the surface of the media, reduce the speed. (Default Setting: 30 cm/s)

#### 4 Press to select a value. Press to enable the setting.

**Evaluating the Results of a Cutting Test**

Check the shape of the test pattern.

The cut shape is distorted. ⇒ Decrease the value of [Speed].

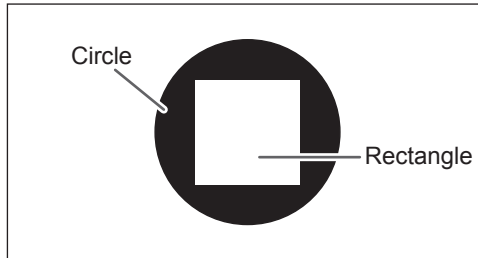

Peel off the circle.

The rectangle also peels off. ⇒ Increase the value of [Force].

Some uncut areas remain. ⇒ Decrease the value of [Speed].

Peel off the rectangle.

The blade should leave faint traces on the backing paper. ⇒ Do not change the value of [Force].

The blade trace is indistinct. ⇒ Increase the value of [Force].

The blade trace is too deep and cuts into the backing paper. ⇒ Decrease the value of [Force].

Check the shape of the rectangle.

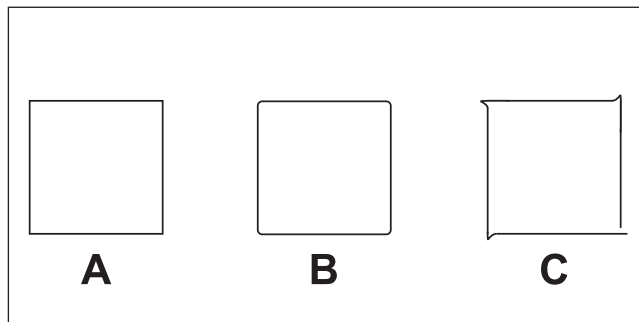

A ⇒ Do not change the value of [OFFSET].

B (The corners are rounded.) ⇒ Increase the value of [OFFSET].

C (The corners have "horns.") ⇒ Decrease the value of [OFFSET].

5 Press   in this order to go back to the original screen.



## Accurately Adjusting the Cutting-in Amount

When you want to perform accurate and fine adjustment of the cutting-in amount, such as when cutting media with thin backing paper, you can obtain good results by adjusting the tip of the blade. Turn the cap portion of the blade holder to adjust the amount of blade extension. Each indicator tick corresponds to 0.1 millimeters, and adjustment for 0.5 millimeters can be made by rotating the cap one full turn.

Note that making the amount of blade extension too small may cause the tip of the blade holder cap to touch, and may soil and damage the printed surface. It's important to be especially careful about this when you're using media that has poor ink adhesion properties.

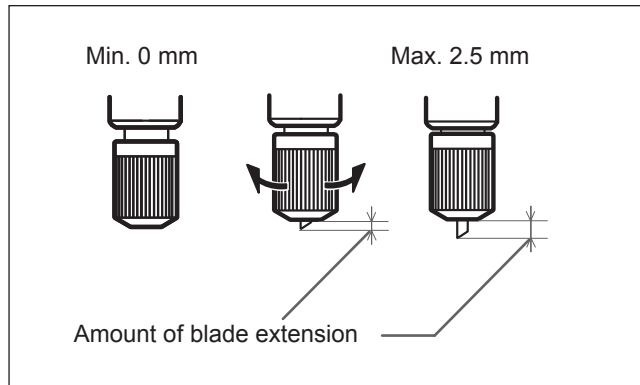

### Rough Estimate for the Amount of Blade Extension



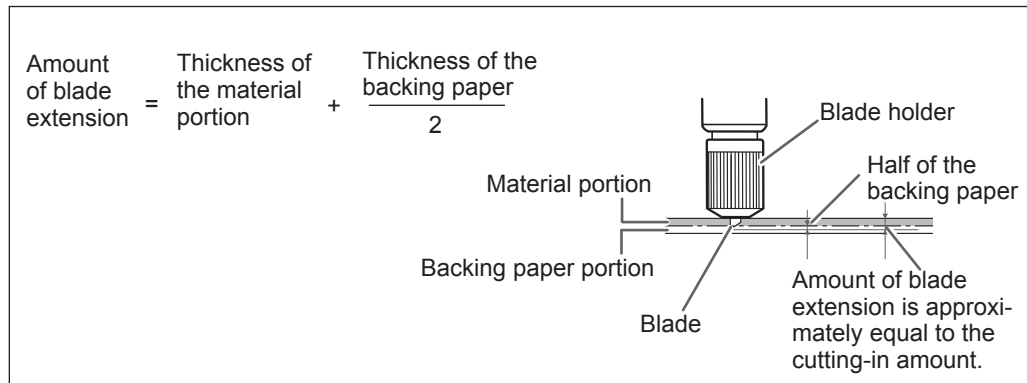

Use the following dimension as a rough estimate for setting the amount of blade extension.



## Performing Distance Correction During Cutting

\*When you're performing printing followed by cutting, be sure to set the correction value to "0.00%." Otherwise the printing and cutting positions may become misaligned

### Procedure

- 1 Hold down **MENU** and press **CUT CONFIG**.
- 2  Press **▼** twice to display the screen shown on the left.  
Press **▶**.
- 3   
 Press **▶**.  
Press **▲** **▼** to select a correction value.  
Set the correction value of media feed direction.  
Press **ENTER** to enable the setting.  
Press **◀**, and then **▼**.
- 4   
 Press **▶**.  
Press **▲** **▼** to select a correction value.  
Set the correction value of head movement direction.  
Press **ENTER** to enable the setting.
- 5 Press **MENU** **◀** in this order to go back to the original screen.

### Description

The movement distance of the media changes subtly depending on the media's thickness. This means that the length of a line when cut may differ from the length setting in the data. You enter a correction value when you want to align the lengths.

### Default Setting

[FEED SETTING]: 0.00%

[SCAN SETTING]: 0.00%

## Correcting Misalignment of the Printing and Cutting Positions

Note: When performing this setting, make sure to set the correction value of [CUTTING MENU CALIBRATION] to "0.00%."

☞ P. 104, "Performing Distance Correction During Cutting"

### Procedure

**1 Make sure the [AUTO ENV. MATCH] menu item is set to "ENABLE."**

☞ P. 108, "Viewing the Automatic Environment Correction Function Settings"

**2 Perform bidirectional adjustment.**

☞ P. 91, "Correcting for Misalignment in Bidirectional Printing"

☞ P. 92, "Correcting for Misalignment in Bidirectional Printing More Precisely"

**3 Hold down **MENU** and press **CUT CONFIG**.**

**4**  **Press** .

**5**  **Press** .

The test pattern (P&C1) is printed and cut. The test pattern is printed at three locations on the media: at the two edges and in the center. **When adjustment is needed, go on to the next Procedure.**

**To check the test pattern (P&C1)**

Check to make sure that the printing position and the cutting position are aligned.

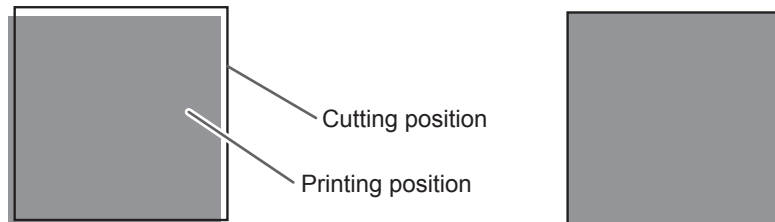

Printing position and Cutting position are misaligned.

Printing position and Cutting position are aligned.

**6**  **Press**  **to display the left figure.**  
**Press** .

The test pattern (P&C2) is printed and cut.

For information on the method of test pattern check, refer to the next page.

**To check the test pattern (P&C2)**

The point where the cutting line intersects the correction-value scale is the correction value. Check the scan direction and feed direction respectively.

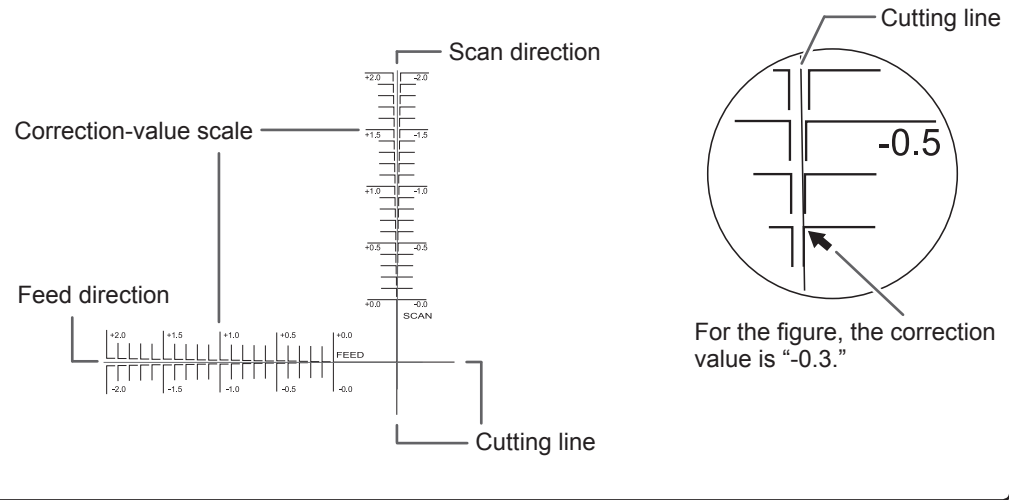

7 PRINT-CUT ADJ. SETTING

Press **▲** to display the left figure.  
Press **▶**.

8 F : -0.30 ▶ -0.30mm  
S : 0.00 ▶ -0.20mm

Press **▲** **▼** to select a correction value of [F] (feed direction of media).  
Press **◀** **▶** to select a correction value of [S] (movement direction of head).  
Press **ENTER** to enable the setting.

9 PRINT-CUT ADJ. TEST PRINT

Press **MENU** **▲** in this order to display the left figure.  
Press **ENTER**.

The test pattern (P&C1) is printed and cut. If the printing and cutting lines are aligned, adjustment is complete. If further adjustment is needed, go back to Procedure 8 and fine-tune the adjustment.

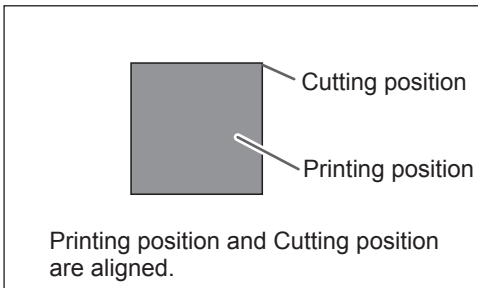

---

## Description

---

You perform this when printing followed immediately by cutting yields positioning for printing and cutting that is slightly misaligned. You print alignment marks, perform detection of the printed marks, and correct the discrepancy. Subtle misalignment between the printing and cutting positions may occur due to the thickness of the media or the head height. We recommend making correction to match the media you're using.

---

## Default Setting

---

[F] (correction value of media feed direction): 0.00 mm

[S] (correction value of head movement direction): 0.00 mm

## Prioritize The Cuttings Settings of This Machine to The Settings of a Computer Side in Software RIP

---

### Procedure

---

- 1 Hold down **MENU** and press **CUT CONFIG**.
- 2 

|               |    |
|---------------|----|
| CUTTING MENU  | ◀▶ |
| CUTTING PRIOR | ▶  |

 Press **▲** twice to display the left figure.  
Press **▶**.
- 3 

|                |    |
|----------------|----|
| CUTTING PRIOR  | ◀▶ |
| COMMAND ▶ MENU | ↵  |

 Press **▲** **▼** to select "MENU."  
Press **ENTER** to enable the setting.
- 4 Press **MENU** **◀** in this order to go back to the original screen.

---

## Description

---

You can also make the settings for the cutting conditions using the software RIP. By default, the settings made with the software RIP take priority. To make the cutting conditions set on the machine take priority, either turn off the settings of the software RIP or make the setting described above.

---

## Default Setting

---

[CUTTING PRIOR]: COMMAND

## Viewing the Automatic Environment Correction Function Settings

The automatic environment correction function is the function that adjusts automatically to the optimal condition of this machine according to the operating environment (humidity and temperature). Performing automatic adjustment can reduce misalignment in the scanning direction (the direction of head movement) during printing or cutting. Normally set to "ENABLE."

### Procedure

1 Hold down **MENU** and press **CUT CONFIG**.

2  Press **▲** to display the left figure.  
Press **▶**.

3  Check that setting is "ENABLE."  
Press **▲** **▼** to select an item to change the setting.  
Press **ENTER** to enable the setting.

4 Press **MENU** **◀** in this order to go back to the original screen.

### Default Setting

[AUTO ENV. MATCH]: ENABLE

# Performing Printing and Cutting Separately

## To Perform Printing and Cutting Separately

You can remove the printed media and then reload it and perform cutting.

(Example: Perform lamination or other processing after printing, then reload the media and perform cutting.)

Then, carry out alignment to prevent misalignment of the printing results and the cut lines. Perform this adjustment in the next Procedure.

### Procedure

#### 1 Printing with Crop Marks.

☞ P. 109, "Printing with Crop Marks"

#### 2 Align to the printed crop marks and perform cutting.

You can detect the crop marks automatically or manually.

☞ P. 111, "Aligning Automatically and Cutting"

☞ P. 113, "Aligning Manually and Cutting"

Note: Correct misalignment of the printing and cutting positions, if applicable.

☞ P. 114, "Correcting Misalignment for Printing and Cutting Position When Using Crop Marks"

## Printing with Crop Marks

Use your software RIP to make the settings for printing crop marks. For information on how to make the setting, refer to the documentation for the software RIP you're using.

### IMPORTANT!

Alignment marks and symbols drawn using a graphics program cannot be used as crop marks.

The crop marks are printed as shown in the figure.

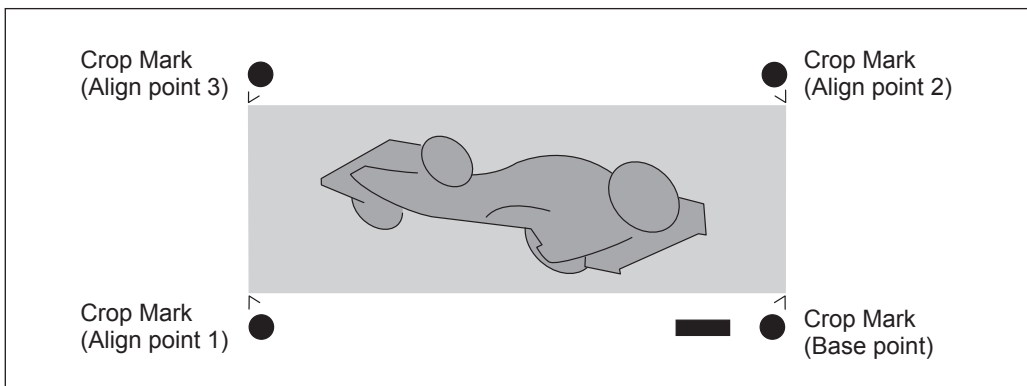

Media Sizes Allowing Automatic Crop Mark Detection

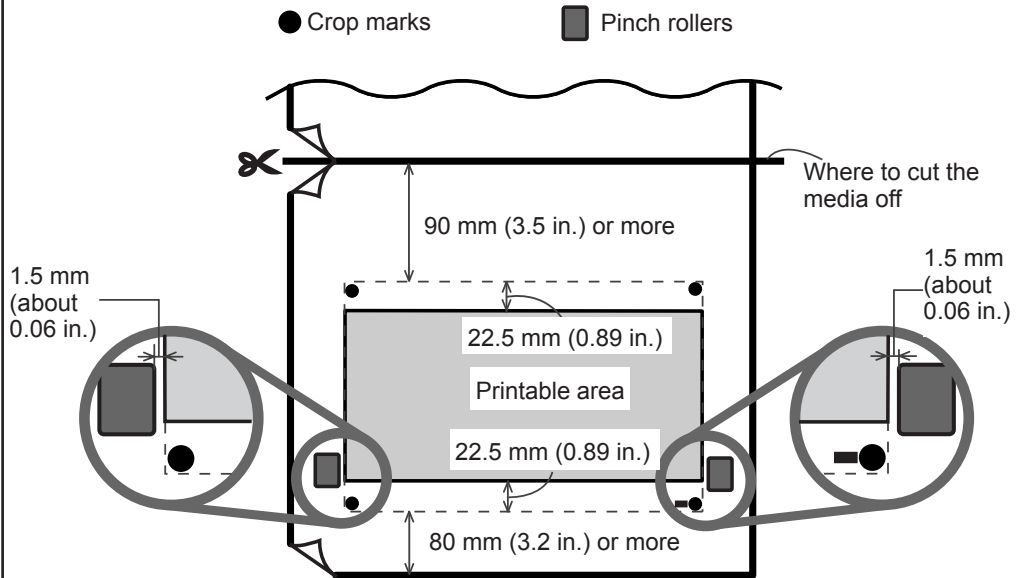

When you are printing with crop marks, set a margin of at least 90 mm (3.5 in.) before the next printstart position. You can set the margin value with the software RIP you're using. For information on how to make the setting, refer to the documentation for the software RIP you're using.



## Aligning Automatically and Cutting

When you make the setting for reading crop marks when sending cutting data from the computer, alignment is performed with the presence or absence of crop marks determined automatically. For information on how to make the setting, refer to the documentation for the software RIP you're using.

### Points for Media Setting

Place the crop marks on the blade protector.

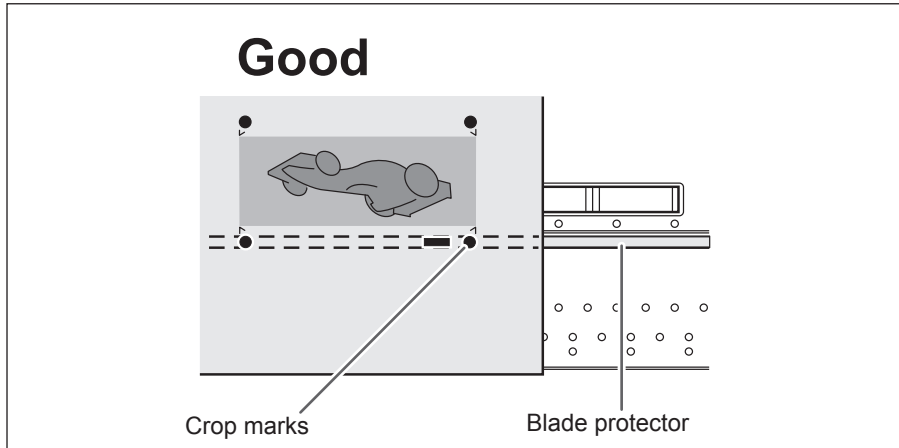

Angled no more than 5 degrees. Otherwise alignment becomes impossible.

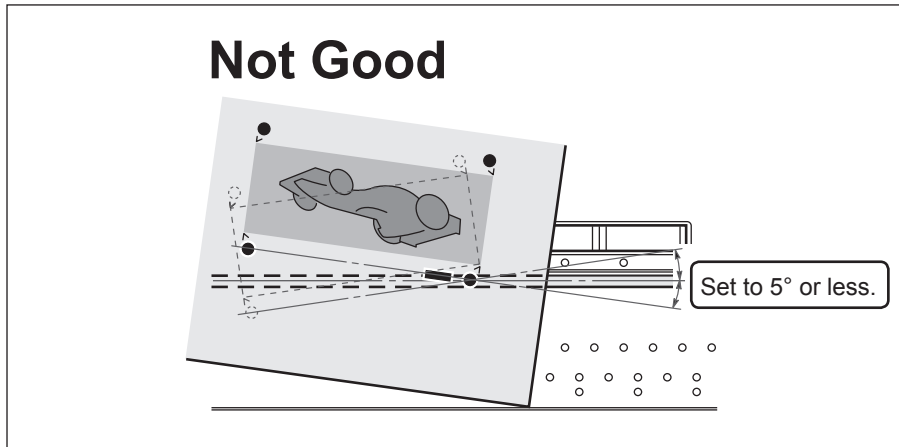

### If Automatic Alignment Cannot Be Performed

CROPMARK ERROR  
NOT FOUND

If the machine fails to detect the crop marks, the screen shown in the figure appears and operation stops.

Press any key to go back to the original screen.

Reload the media, and then send the data again.

\*When you want to perform automatic alignment with lengthy media, we recommend performing output with the data separated into sizes that are as short as possible.

The crop marks cannot be detected easily because of the effects of media warping or the like. With large sizes, error due to warping and the like increases, making smooth detection impossible. In such the cases, perform alignment manually.

☞ P. 113, "Aligning Manually and Cutting"

### To Quit Detection and Start Cutting

#### Procedure

- 1 Press **PAUSE** during detection of crop marks.

Crop-mark detection stops. Depending on the content of the data, some time may pass before detection actually stops.

- 2 

CANCEL CROPMARK  
DETECTION? ↵

Press **ENTER**.

This stops detection and starts cutting.

\*Note: After pressing **PAUSE** in Procedure 1, resuming detection or canceling output is also possible.

☞ P. 114, "Correcting Misalignment for Printing and Cutting Position When Using Crop Marks"

## Aligning Manually and Cutting

Depending on the type of media, it may not be possible to detect crop marks automatically. When crop marks cannot be detected automatically, you perform alignment manually.

### 1. Set the base point.

- ① Use     to align the center of the blade with the location shown in the figure.

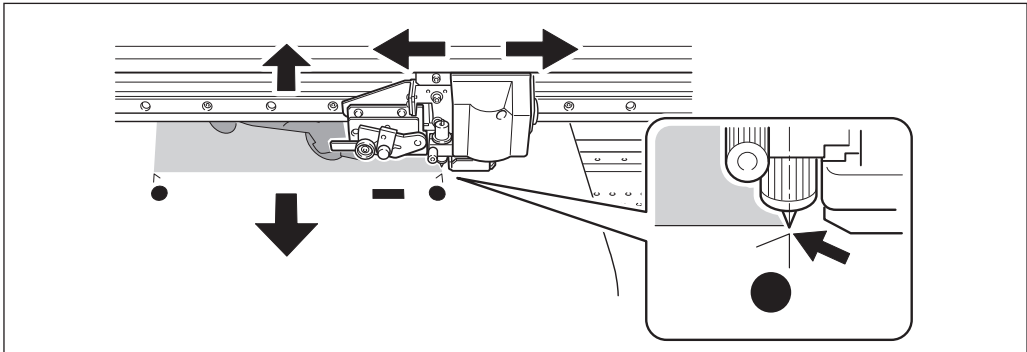

- ② Press .

|          |
|----------|
| W 1200mm |
| B        |

The character "B" appears on the lower left of the setting screen. The base point is set.

### 2. Set the align points.

- ① Use     to align the center of the blade with the location shown in the figure.

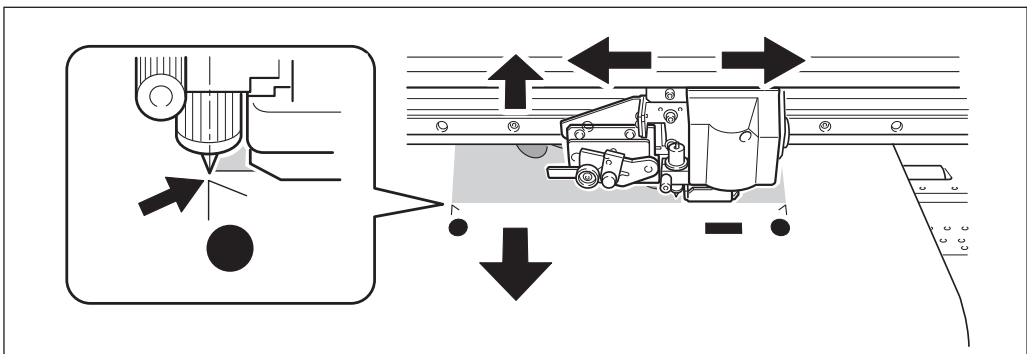

2 Hold down **BASE POINT** for one second or longer.

3 

When the screen shown in the figure appears, press **ENTER**.

The number of the align point you set is automatically determined.

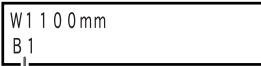

Align point is set.

This indicates that the base point and align point 1 have been set.

4 Repeat Procedure 1 ~ 3 to specify other align points as required.

5 Send the cutting data and perform cutting.

**POINT!** About Align Points

The numbers for align points are determined with reference to the location of the base point. You cannot set an align point unless you specify a base point. Redoing the setting for the base point clears any align points that have been set.

## Correcting Misalignment for Printing and Cutting Position When Using Crop Marks

Note: When performing this setting, make sure to set the correction value of [CUTTING MENU CALIBRATION] to "0.00%."

☞ P. 104, "Performing Distance Correction During Cutting"

### Procedure

1 Make sure the [AUTO ENV. MATCH] menu item is set to "ENABLE."

☞ P. 108, "Viewing the Automatic Environment Correction Function Settings"

2 Perform bidirectional adjustment.

☞ P. 91, "Correcting for Misalignment in Bidirectional Printing"

☞ P. 92, "Correcting for Misalignment in Bidirectional Printing More Precisely"

3 Hold down **MENU** and press **CUT CONFIG**.

4 

Press  to display the left figure.

Press .

5 CROP-CUT ADJ. TEST PRINT

Press **ENTER**.

The test pattern (C&C1) is printed and cut.

When adjustment is needed, go on to the next Procedure.

**To check the test pattern (C&C1)**

Check to make sure that the printing position and the cutting position are aligned.

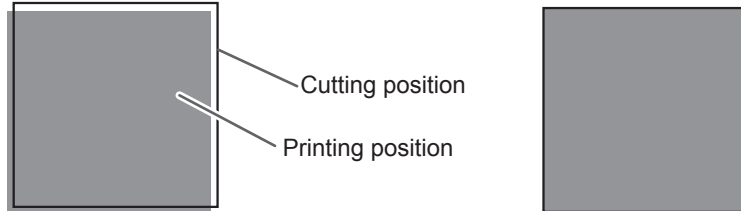

Printing position and Cutting position are misaligned.

Printing position and Cutting position are aligned.

6 CROP-CUT ADJ. TEST PRINT 2

Press **▲** to display the left figure.

Press **ENTER**.

The test pattern (C&C2) is printed and cut.

**To check the test pattern (C&C2)**

The point where the cutting line intersects the correction-value scale is the correction value. Check the scan direction and feed direction respectively.

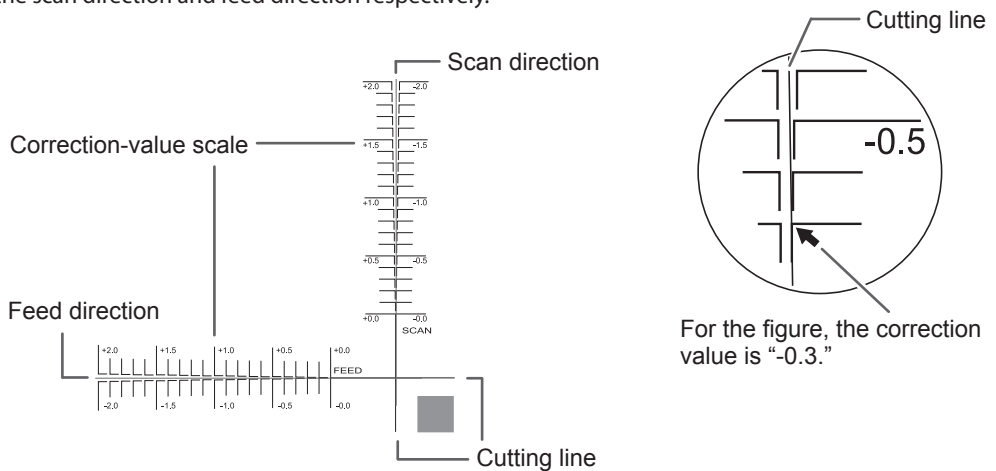

7 CROP-CUT ADJ. SETTING

Press **▲** to display the left figure.

Press **▶**.

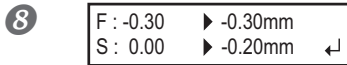

Press **▲** **▼** to select a correction value of [F] (feed direction of media).

Press **◀** **▶** to select a correction value of [S] (movement direction of head).

Press **ENTER** to enable the setting.



Press **MENU** **▲** in this order to display the left figure.

Press **ENTER**.

The test pattern (C&C1) is printed and cut. If the printing and cutting lines are aligned, adjustment is complete. If further adjustment is needed, go back to Procedure 8 and fine-tune the adjustment.

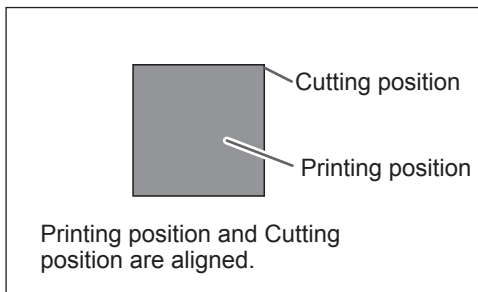

### Description

Depending on the composition of the media, the positioning of printing and cutting may be misaligned even when you're using crop marks. Make corrections for misaligned printing and cutting for the media you're using.

### Default Setting

[F] (feed direction): 0.00 mm

[S] (scanning direction): 0.00 mm

# Using Media Take-up System

## Features of the Take-up System

Using the take-up unit lets you perform printing while the media is taken up automatically. This makes possible unattended operation at night and efficient output of lengthy media.







## What to Select at the Time of Media Setup

When the take-up system is used, select "TU" or "TU2" in [SETUP SHEET]. "TU" and "TU2" have the following features.

|            |   |
|------------|---|
| <b>TU</b>  | This performs printing operation while automatically taking up the output media. Select this when only printing operation is performed, not accompanied by taking-back operation.   |
| <b>TU2</b> | Select this when printing operation is accompanied by taking-back operation, such as when only cutting operation or printing & cutting operation is performed. The media is not taken up when output is performed before taking-back operation. Note that outputting for a long time at once may cause the media to touch the work floor and get dirty.<br>☞ P. 88, "Control of Media Heating System during Preheating" |

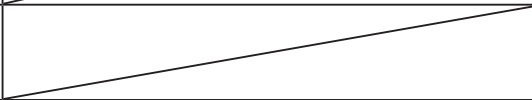
## Operating Conditions for the Take-up System

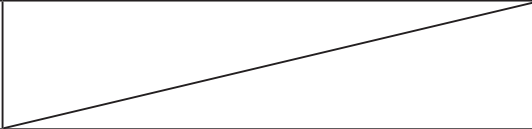
Some operating conditions for the take-up system differ between "TU" and "TU2."

| TU  | TU2  |
|---|--|
| <b>Never operate the MANUAL switch for the take-up unit when the loading lever is pulled back.</b>  |  |
| <p><b>Do not feed the media reversely by pressing .</b><br/>It may cause an error because the media is pulled with excessive force.</p>  |  |
| <p><b>Do not use the automatic cut-off function.</b><br/>When the setting to execute automatic cutoff of the media is made on the software RIP, media cutoff is performed when printing of one page finishes. When you're performing continuous printing and take-up for two or more pages, turn off the automatic-cutoff feature on the software RIP. Take-up quits as soon as the media is cut off.</p> |  |
| <p><b>Never Use When Performing Cutting</b><br/>Never use the take-up unit when you're performing cutting operations. Use is possible only when performing printing.</p>  |  |
| <p><b>When feeding out media toward the front of the machine by pressing , be sure to set the base point.</b></p>  |  |
| <p><b>Set the [PREFEED] setting-menu item to "DISABLE."</b></p>   |  |
| <p><b>Set the [FEED FOR DRY] setting-menu item to "DISABLE."</b><br/>☞ P. 88, "Drying the Trailing Edge of the Printing Area on the Dryer"</p>  |  |
| <p><b>Margin Settings</b><br/>If you can set the margins on the computer, set them each to 40 millimeters or more.</p>  |  |

## About the Paper Tube

***For the paper tube, use the included item.***

The included paper tube is a special part exclusively for use with this machine. Using something other than the included item may result in spinning without traction or other problems that impede media take-up.

***The paper tube is a part that wears out.***

The paper tube is a part that wears out. The replacement cycle varies according to usage conditions, but to ensure good media take-up, monitor the state of the paper tube and replace it when necessary. To purchase a replacement, contact your authorized Roland DG Corp. dealer.

## How to Take Up Media

### 1. Pass the media through the printer.

1

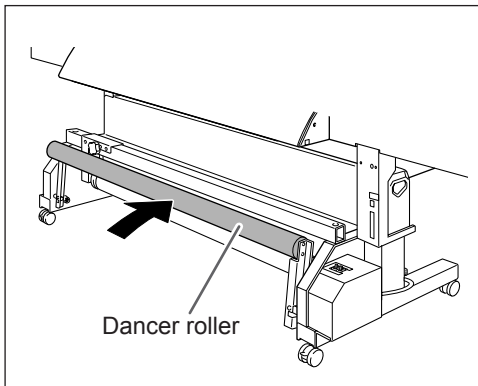

Move the dancer roller toward the rear.

2

**Load the roll media.**

☞ P. 19, "Loading Media"

3

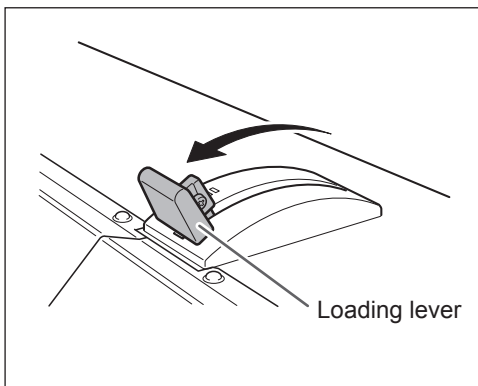

Pull back the loading lever to secure the media in place.



## 2. Fasten the media to the paper tube.

When you attach the paper tube, insert it securely onto the end caps on the take-up unit. For information on how to attach the paper tube, refer to the Setup Guide.

1  Press   to select "TU" or "TU2."

 Press .

2  Press  to pull out the media until its leading edge reaches the paper tube.

You can adjust the length of the media in 10-millimeter steps by pressing  (To pull out media continuously, hold down the key.)

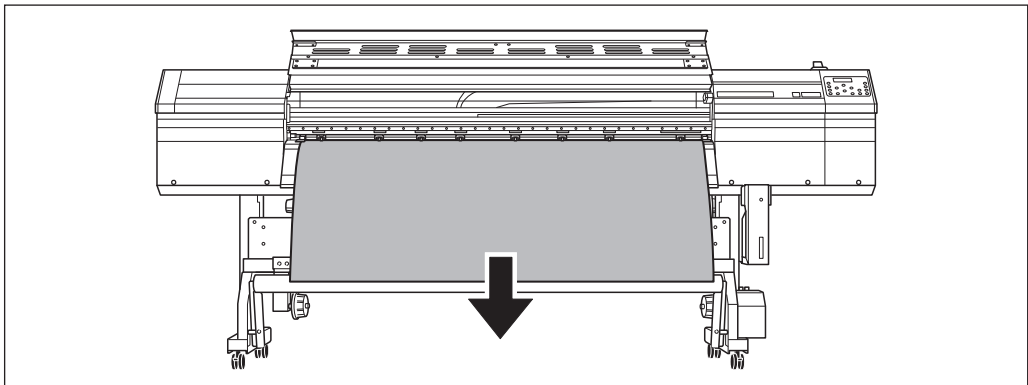

3 Fasten the media in place with tape at three locations (the center and both edges) so that the media is not at an angle.

### ■ Take-up with outward curl

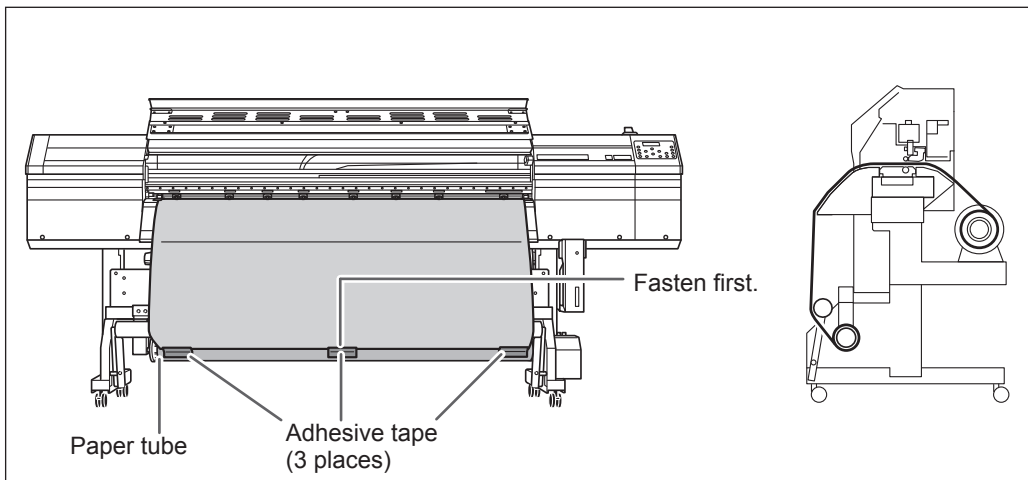

■ Take-up with inward curl

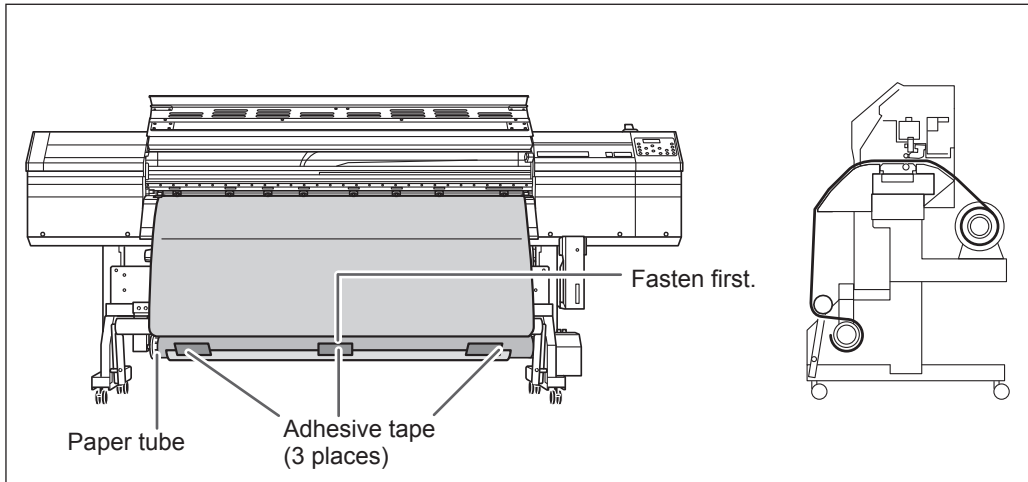

4 Press **ENTER**.

The media is fed out to the front.

5 

|                                |   |
|--------------------------------|---|
| TILT DANCER<br>ROLLER TO FRONT | ↵ |
|--------------------------------|---|

**Pull the dancer roller back toward you.**

**Make sure the media is stretched taut, and press **ENTER**.**

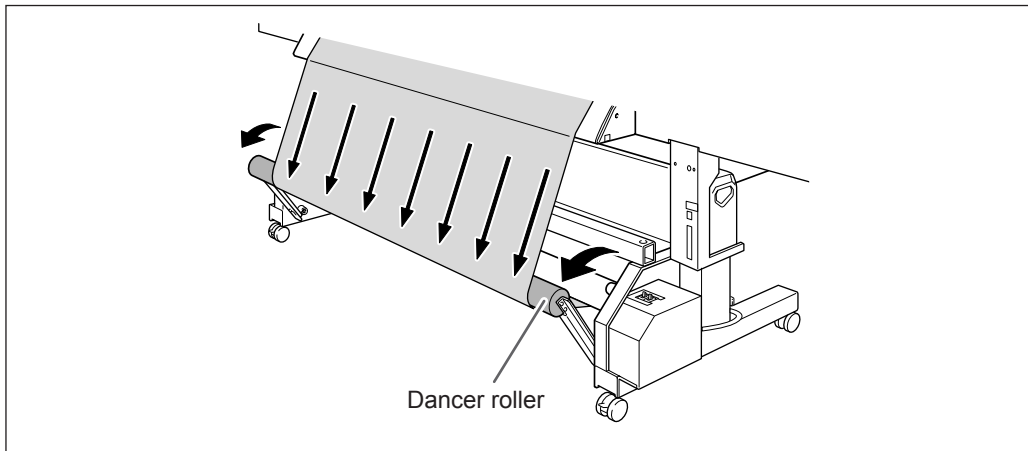

### 3. Make the settings for the take-up unit.

1

CHECK  
TAKE-UP SETTING ↵

Make the setting for the AUTO switch on the take-up unit.

#### ■ Take-up with outward curl

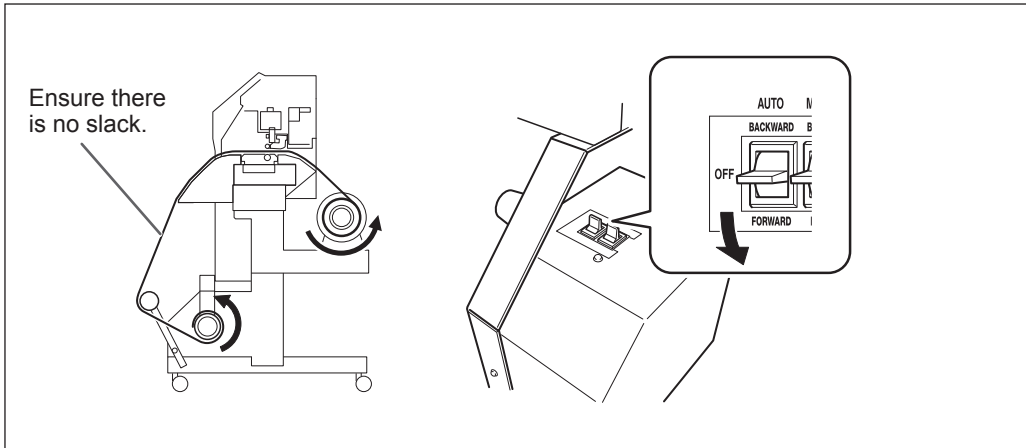

#### ■ Take-up with inward curl

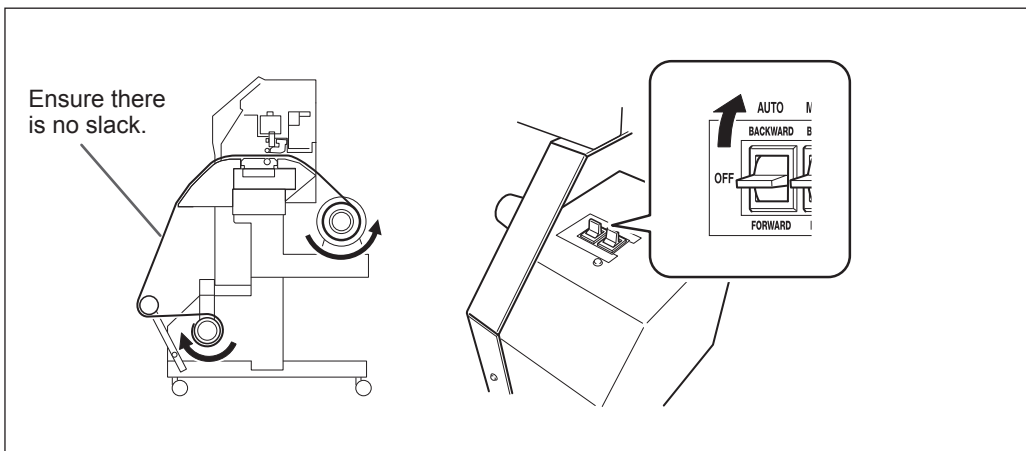

When you begin take-up, take care to ensure that the end of the media does not become rolled or creased.

2

Press **ENTER**.

W 1200 m

Making the setting is complete when this screen appears.

4

Part of  
Practice

## How to Operate the MANUAL Switch on the Take-up Unit

You can take up media by using the MANUAL switch.

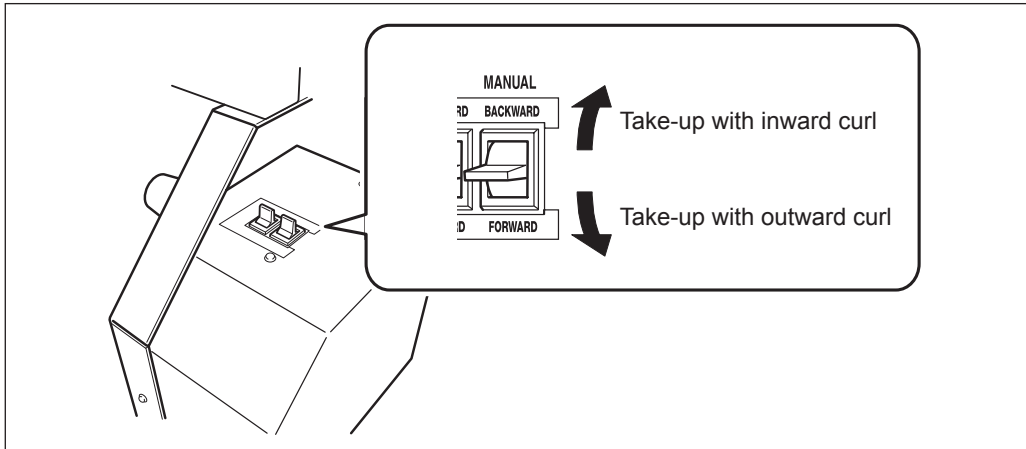

## About Length Output At One Time When "TU2" is selected

If too long media is output at one time when "TU2" is selected, the media may get soiled by touching the work floor. To avoid the media from getting soiled by touching the floor, output the media by about 300 mm. To output by limiting the length, use the function of software RIP.

☞ Refer to the following when Roland VersaWorks Dual is used.

## How to Output by Limiting Length

For information on the detail usage of VersaWorks series, refer to the link below.

- VersaWorks Dual  
☞ <https://webmanual.rolanddg.com/RolandVersaWorksDual>
- VersaWorks 6  
☞ <https://webmanual.rolanddg.com/VersaWorks6>

## When using Versa Works Dual

### 1 Open "Que Properties" window (or "Job Setting" window)

Select the input folder to be used.

### 2

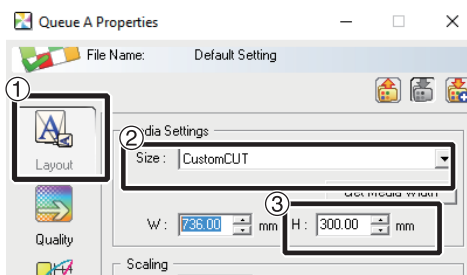

1 Click .

2 Select "CustomCUT" from [Size] under "Media Settings."

3 Set "H."

Que Properties window  
(The setting item and the method in "Job Setting" window are the same as this procedure.)

## When using Versa Works 6

For information on the detail usage of VersaWorks series, refer to the link below.

☞ <https://webmanual.rolanddg.com/VersaWorks6>

Output Settings > Setting the Layout > Setting the Media Size

## How to Remove Taken-up Media

### ⚠ CAUTION

Removal of taken-up roll media from the unit is a task which must be carried out by two or more persons.

Injury may result if attempted by one person without assistance.

### Removing Taken-up Media

- 1 **Cut off the media.**  
☞ P. 122, "About Length Output At One Time When "TU2" is selected"
- 2 **Support the paper tube to prevent it from falling.**
- 3 **Loosen the retaining screw and move the arm.**
- 4 **Detach the paper tube from the flanges.**

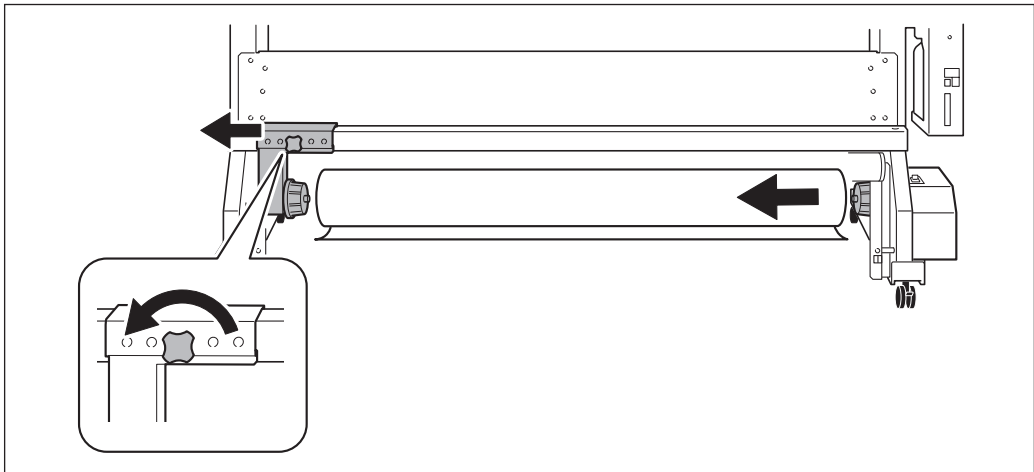

# Chapter 5

## To Administrators

---

|   |     |
|---|-----|
| Output Operation Management .....   | 125 |
| Printing a System Report.....   | 125 |
| Determining What Happens When Ink Runs Out.....   | 125 |
| Displaying the Amount of Media Remaining.....   | 126 |
| Making Sure to Verify the Setting for the Amount Remaining Every<br>Time the Media Is Changed ..... | 127 |
| Printing the Amount of Remaining Media .....  | 128 |
| System Management of Printer .....  | 129 |
| Setting for the Menu Language and the Units of Measurement.....                                     | 129 |
| Setting the Interval until Activation of the Sleep Mode (Power Saving<br>Function).....             | 129 |
| Viewing Information about the System of This Machine.....   | 130 |
| Returning All Settings to Their Initial Values.....   | 131 |
| Changing ink type (ECO-SOL MAX 2).....  | 132 |
| About change of ink type .....  | 132 |
| How to change the ink type .....  | 132 |

# Output Operation Management

## Printing a System Report

This prints system information, including a list of setting values.

### Procedure

- 1 Press **MENU**.
- 2 

|          |    |
|----------|----|
| MENU     | ◀▶ |
| SUB MENU | ▶  |

 Press **▼** several times to display the screen shown on the left.  
Press **▶**.
- 3 

|               |    |
|---------------|----|
| SUB MENU      | ◀▶ |
| SYSTEM REPORT | ↵  |

 Press **▼** several times to display the screen shown on the left.  
Press **ENTER**.  
Start printing.
- 4 Press **MENU** **◀** in this order to go back to the original screen.

## Determining What Happens When Ink Runs Out

This lets you change, according to your purpose, the operation that takes place when an ink cartridge is empty.

### Procedure

- 1 Press **MENU**.
- 2 

|          |    |
|----------|----|
| MENU     | ◀▶ |
| SUB MENU | ▶  |

 Press **▼** several times to display the screen shown on the left.  
Press **▶**.  
Press **▲** twice.
- 3 

|             |    |
|-------------|----|
| SUB MENU    | ◀▶ |
| INK CONTROL | ▶  |

 Press **▶** twice.
- 4 

|              |    |
|--------------|----|
| EMPTY MODE   | ◀▶ |
| STOP ▶ CONT. | ↵  |

 Press **▲** **▼** to select.  
"STOP": Printing pauses immediately when a cartridge becomes empty.  
"CONT" (continue): Printing does not stop when a cartridge becomes empty.  
When a cartridge becomes empty, a warning beep sounds.  
Press **ENTER** to enable the setting.
- 5 Press **MENU** **◀** in this order to go back to the original screen.

### Description

When "STOP" is selected, printing pauses and so colors may be uneven. Ensure a sufficient amount of remaining ink before you begin printing.

When "CONT" is selected, printing does not stop even if ink runs out completely. To replace the cartridge, wait until printing ends or press **PAUSE** to pause printing.





## Default Setting

[EMPTY MODE]: STOP

## Displaying the Amount of Media Remaining

You can display how much of the media in use is left. First, you set the amount of media remaining, the amount remaining is displayed at the top menu until it reaches zero.

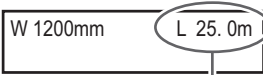
### Procedure

- 1 Press **MENU**.
  - 2  Press **▲** twice to display the left figure. Press **▶**, and then **▼**.
  - 3  Press **▶**.
  - 4  Press **▲** **▼** to set the current amount of media remaining. Press **ENTER** to enable the setting.
  - 5  Press **MENU** **◀** in this order to go back to the original screen.  
This display is updated.
-  If setup has not been performed, the set value flashes.

### Description

If you cancel the setup such as by removing the media or raising the loading lever, the amount remaining at that time flashes on the screen. Because the amount of media remaining is not updated automatically when you change the media, redo the setting whenever you change the media.

Note, however, that when sheet media is loaded (that is, when [SETUP SHEET] is set to "PIECE"), the setting for the amount of remaining media is made automatically.

You can also make the setting display this menu automatically whenever you change the media. See the next section, "Making Sure to Verify the Setting for the Amount Remaining Every Time the Media Is Changed"













Note: The remaining amount that is displayed is only an estimate, and its accuracy is not assured.



## Making Sure to Verify the Setting for the Amount Remaining Every Time the Media Is Changed

Set to display  every time when a media is changed.

### Procedure

- 1 Press .
- 2  Press  twice to display the left figure.  
Press .  
Press  twice.
- 3  Press .
- 4  Press   to select "ENABLE".  
Press  to enable the setting.  
If you set to "ENABLE," you must set the [EDGE DETECTION] menu to "ENABLE."  
☞ P. 95, "Using Transparent Media"
- 5 Press   in this order to go back to the original screen.

### Description

Setting this menu to "ENABLE" can keep you from forgetting to redo the setting when you change the media. Be sure, however, also to set the [EDGE DETECTION] menu (refer to P. 95, "Using Transparent Media") to "ENABLE." When [EDGE DETECTION] is set to "DISABLE," [SHEET REMAIN] is not displayed automatically. Also, when sheet media is loaded (that is, when [SETUP SHEET] is set to "PIECE"), the setting for the amount of remaining media is made automatically, and so this menu is not displayed.

### Default Setting

[AUTO DISPLAY]: DISABLE

## Printing the Amount of Remaining Media

This prints the amount of media remaining that is displayed at the top menu.

### Procedure

- 1 Press **MENU**.
- 2 

|              |    |
|--------------|----|
| MENU         | ◀▶ |
| SHEET REMAIN | ▶  |

 Press **▲** twice to display the left figure.  
Press **▶**.
- 3 

|              |    |
|--------------|----|
| SHEET REMAIN | ◀▶ |
| PRINT MEMO   | ↵  |

 Press **ENTER**.  
Start printing.
- 4 Press **MENU** **◀** in this order to go back to the original screen.

### Description

You use this when you want to make a record of the remaining length of the media now in use. Printing the amount of media remaining before you change the media enables you to refer to the printed record and use the value to make the setting for the remaining amount the next time you use the media.

Note, however, that continuing by performing the next output starts the output on top of the portion where the amount of remaining media is printed. After printing the amount remaining, then before you perform the next output operation, we recommend cutting off the media.

# System Management of Printer

## Setting for the Menu Language and the Units of Measurement

This sets the language and units of measurement displayed on the display screen of the operation panel.

### Procedure

- 1 Hold down **MENU** and switch on the sub power.
- 2 

|               |   |
|---------------|---|
| MENU LANGUAGE | ↕ |
| ENGLISH       | ↵ |

 Use **▲** **▼** to select the display (menu) language.  
Press **ENTER** to enable the setting.
- 3 

|              |   |
|--------------|---|
| LENGTH UNIT  | ↕ |
| mm    ▶ INCH | ↵ |

 Use **▲** **▼** to select the measurement unit for length.  
Press **ENTER** to enable the setting.
- 4 

|            |   |
|------------|---|
| TEMP. UNIT | ↕ |
| °C    ▶ °F | ↵ |

 Use **▲** **▼** to select to the measurement unit for temperature.  
Press **ENTER** to enable the setting.

### Default Setting

[MENU LANGUAGE]: ENGLISH  
[LENGTH UNIT]: mm  
[TEMP. UNIT]: °C

## Setting the Interval until Activation of the Sleep Mode (Power Saving Function)

### Procedure

- 1 Press **MENU**.
- 2 

|          |    |
|----------|----|
| MENU     | ◀▶ |
| SUB MENU | ▶  |

 Press **▼** several times to display the screen shown on the left.  
Press **▶**.
- 3 

|          |    |
|----------|----|
| SUB MENU | ◀▶ |
| SLEEP    | ▶  |

 Press **▲** several times to display the screen shown on the left.  
Press **▶** twice.
- 4 

|                    |    |
|--------------------|----|
| INTERVAL           | ◀▶ |
| 30 min    ▶ 15 min | ↵  |

 Use **▲** **▼** to make the setting.  
Press **ENTER** to enable the setting.
- 5 

|             |  |
|-------------|--|
| W 1346 mm   |  |
| SETUP SHEET |  |
| ◀▶ ROLL     |  |

 Press **MENU** **◀** in this order to go back to the original screen.

### Default Setting

[INTERVAL]: 30 min

## Viewing Information about the System of This Machine

Note: For information on how to set up a network, refer to "Setup Guide."

### Procedure

1 Press **MENU**.

2 

Press **▲** several times to display the screen shown on the left.

You can view the following information.

[MODEL]: Model name

[SERIAL NO.]: Serial number

[INK]: Ink type

[FIRMWARE]: Firmware version

[NETWORK]: Network setting such as IP address

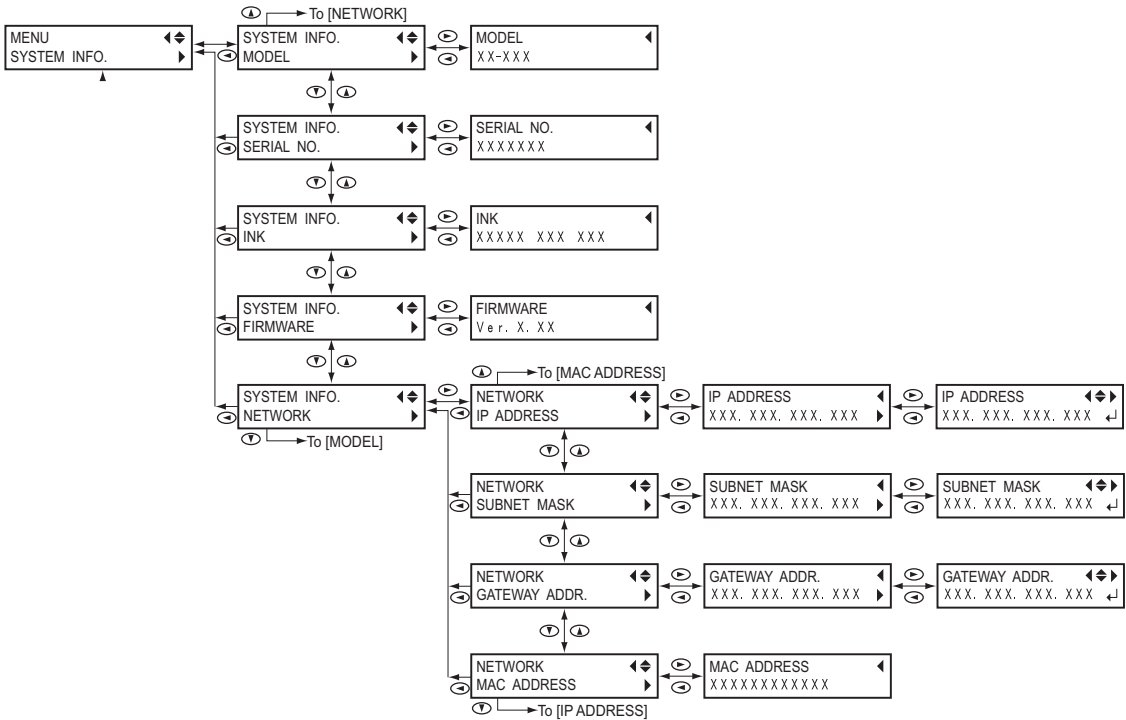

## Returning All Settings to Their Initial Values

This menu returns all settings to the same as their factory defaults. However, the settings for [MENU LANGUAGE], [LENGTH UNIT], and [TEMP. UNIT] are not returned to the factory defaults.

### Procedure

- 1 Press **MENU**.
- 2 

|          |    |
|----------|----|
| MENU     | ◀◆ |
| SUB MENU | ▶  |

 Press **▼** several times to display the screen shown on the left.  
Press **▶**.
- 3 

|                 |    |
|-----------------|----|
| SUB MENU        | ◀◆ |
| FACTORY DEFAULT | ↵  |

 Press **▼** several times to display the screen shown on the left.  
Press **ENTER** to execute.

# Changing ink type (ECO-SOL MAX 2)

\* This function is exclusive for ECO-SOL MAX 2. When using ECO-SOL MAX 3, you can't use this function.

## About change of ink type

On this machine, you can change the ink type by yourself only in the following cases:

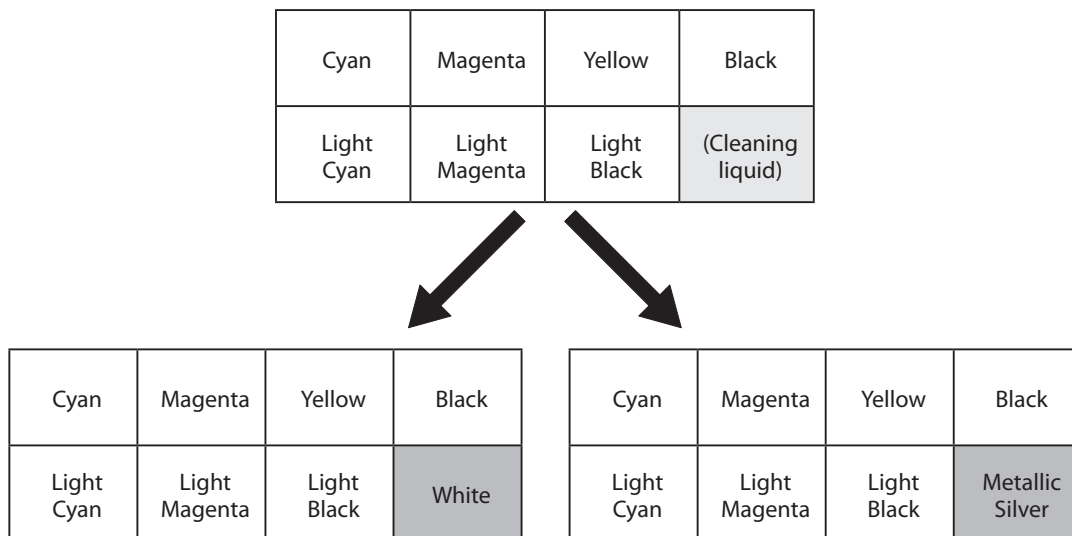

## How to change the ink type

This task requires the following items. Prepare them before starting the task.

- New dummy cartridge: 6 pieces
- Cleaning liquid
- Cleaning stick

Contact your authorized Roland DG Corp. dealer for purchasing them.

### 1. Drain ink in the machine.

- 1 Press **MENU**.
- 2 

|          |    |
|----------|----|
| MENU     | ◀▶ |
| SUB MENU | ▶  |

 Press **▼** several times to display the left figure.  
Press **▶**.
- 3 

|             |    |
|-------------|----|
| SUB MENU    | ◀▶ |
| INK CONTROL | ▶  |

 Press **▲** several times to display the left figure.  
Press **▶**, and then **▼**.
- 4 

|             |    |
|-------------|----|
| INK CONTROL | ◀▶ |
| PUMP UP     | ↵  |

 Press **ENTER**.

5  Confirm that the drain bottle is loaded, and then press .

6 **By following the on-screen instructions, remove and insert the SOL INK cartridges and dummy cartridges.**

7  When draining of the ink is complete, the message shown in the figure appears.  
**Dismount the drain bottle and discard the drained ink.**  
**After discarding the drained ink, mount the drain bottle again.**

8 Press .  
 The sub power is switched off.

**IMPORTANT!**  
 Go on to the next procedure as soon as the sub power is switched off. If you leave the machine with ink drained, it damages the print heads.

## 2. The sub power is switched off.

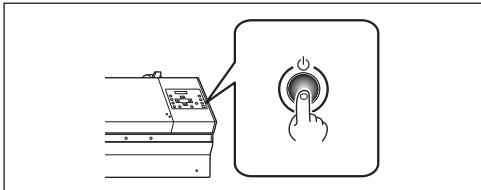



1  Press the sub power button.

2  Press  or .

3  Press   to select ink type.  
 Select the ink type according to which color is used, white or metallic silver.

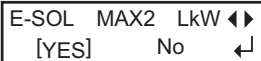
| White (WH) | Metallic silver (MT) | Ink Mode        |
|------------|----------------------|-----------------|
| ○          | /                    | E-SOL MAX2 LkW  |
| /          | ○                    | E-SOL MAX2 LkMT |

4 After selecting the Ink Type, press .

5  Confirm the Ink Type is correct, and then use   to select [Yes].  
 Press .

6  Make sure the drain bottle is installed.  
 Press .

### 3. Clean using the cleaning stick.

1

OPEN COVER R

When the message shown on the left appears, remove the cover R.

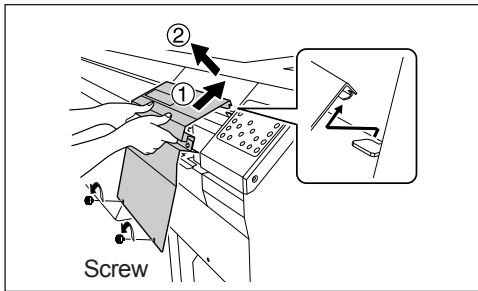

Remove the screws, lift the cover R in the direction of ①, and then pull it out in the direction of ②.

2

APPLY  
CLEANING LIQUID ←

When the message shown on the left appears, put the cleaning stick in the cleaning liquid and clean the indicated location.

Use one cleaning stick per cleaning session, then discard the stick after use. Reusing cleaning sticks may reduce printing quality.

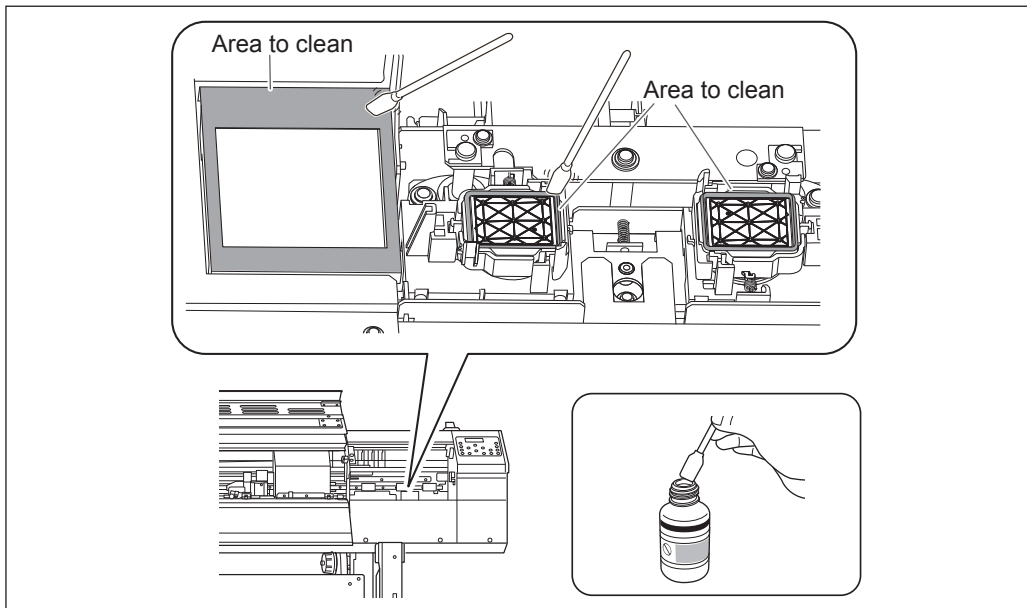

3

After cleaning, install the cover R.

4

APPLY  
CLEANING LIQUID ←

Press **ENTER**.



## 4. Insert the ink cartridge for each color.

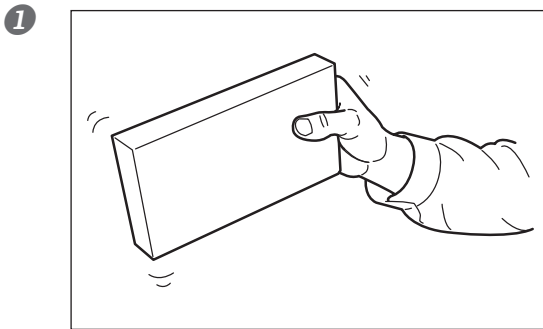

Before you insert the ink cartridge for each color, gently shake the cartridge.

2  
SET SOL CRT.  
7 8

Insert Ink cartridges into slots 7 and 8.

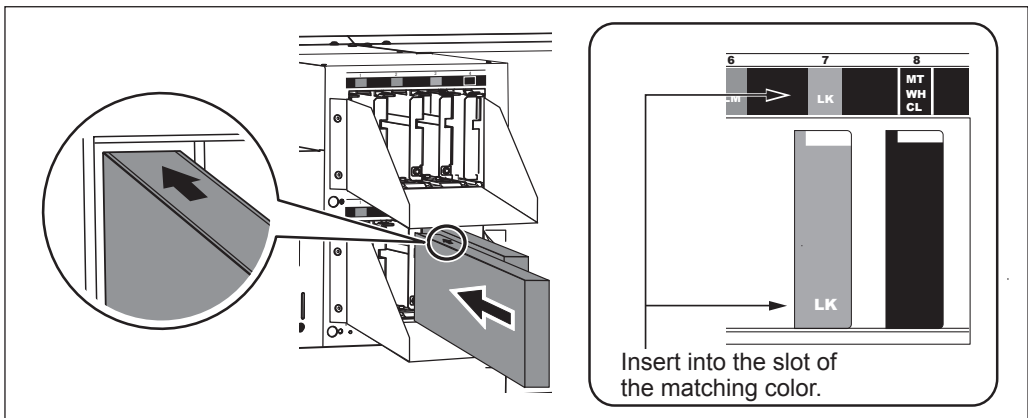

3  
SET DUMMY CRT.  
1 2 3 4 5 6

Insert the dummy cartridges into slots from 1 to 6 .

Press **ENTER** .

FILLING INK...  
>>>

4  
REMOVE DUMMY CRT.  
1 2 3 4 5 6

Pull out the dummy cartridges of slots 1 to 6 .

Press **ENTER** .

5  
SET SOL CRT.  
1 2 3 4 5 6 7 8

Insert the ink cartridge for each color.

Insert the cartridges into the cartridge slots of the matching color.

FILLING INK...  
>>>>>>>>>>>>>>>>>>

## 5. Clean the print heads.

### IMPORTANT!

This operation takes about 5 minutes. During this operation, do not walk away from the machine and complete this operation by following the on-screen instructions. Walking away before the operation is complete may cause damage to the print heads, making the machine unusable.

1

CLOSE THE VALVE

Insert the provided hexagon wrench into the hole shown in the figure below. Rotate it in the direction of arrow until the buzzer sounds once and hold it with your hand.

The valve will close.

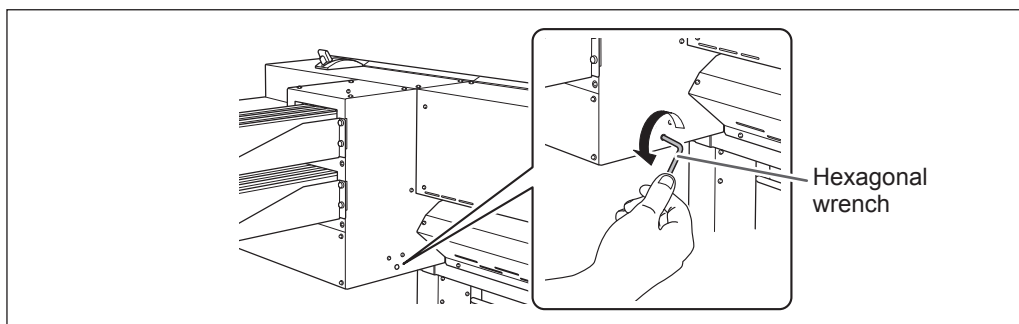

NOW PROCESSING..

While holding the hexagon wrench with your hand, wait until the next instruction is displayed.

2

OPEN THE VALVE

When the screen shown to the left appears and the buzzer sounds twice, rotate the hexagon wrench in the direction of the arrow shown in the figure below until the buzzer sounds once.

The valve opens.

Open the valve immediately although cleaning continues inside the machine even after the screen shown on the left appears. Leaving the valve closed may cause damage to the print heads.

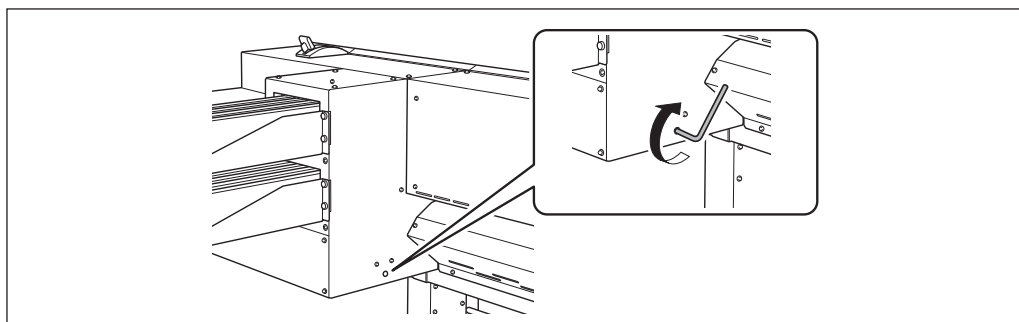

NOW PROCESSING..

Wait until the displayed next operation appears.

3 By following the on-screw instruction, repeat steps 1 and 2.

4

CHECK  
DRAIN BOTTLE ↵

Make sure no fluid is overflowing from the drain bottle and press **ENTER**.



SETUP SHEET  
◀▶ROLL

When this screen appears, filling with ink is finished.

# **Chapter 6**

## **Read This Chapter Whenever You Face a Problem. (FAQ)**

---

|  |     |
|--|-----|
| Printer Does Not Start Up! .....                               | 139 |
| The Printer Unit Doesn't Run.....                              | 139 |
| The Media Take-up System Doesn't Run .....                     | 140 |
| The Media Heating System Doesn't Warm Up .....                 | 141 |
| Cannot cut off the media .....                                 | 141 |
| Cannot select "EDGE" and "PIECE" .....                         | 141 |
| Attractive Printing or Cutting is Impossible.....              | 142 |
| Printed Results Are Coarse or Contain Horizontal Stripes ..... | 142 |
| Colors Are Unstable or Uneven .....                            | 143 |
| The Media Becomes Soiled When Printed.....                     | 144 |
| Cutting Is Misaligned or Skewed .....                          | 145 |
| Media Jam Occurs!.....   | 146 |
| The Media Jams .....   | 146 |
| Media Feed is Not Smooth .....                                 | 147 |
| Media Wrinkles or Shrinks .....                                | 147 |
| Media Feed Is Not Straight.....                                | 148 |
| Media Feed Is Not Smooth.....                                  | 148 |
| The Media Cannot Be Taken Up Smoothly.....                     | 149 |
| The Media Cannot Be Taken Up Smoothly .....                    | 149 |
| Print Heads Stop Moving. Why? .....                            | 150 |
| What to Do First.....  | 150 |
| If the Print Heads Still Do Not Move .....                     | 150 |
| A Message Appears .....  | 152 |
| An Error Message Appears.....                                  | 154 |

# Printer Does Not Start Up!

## The Printer Unit Doesn't Run

### Is the power switched on?

Switch on the printer's main power, then press the sub power switch and make sure the sub power switch lights up.

☞ P. 18, "Switch On!"

### Is **SET UP** illuminated?

Output is not performed when **SET UP** is not illuminated.

Pull back the loading lever, close the front cover, and press **SET UP**.

☞ P. 47, "Getting Ready to Receive Data from a Computer"

### Is the front cover open?

Close front cover, cover L and cover R.

### Is the top menu displayed?

#### Top menu



W 1200 m

If the top menu isn't displayed, output doesn't start even when data is sent from the computer. To go to the top menu, press **MENU**, then press **◀**.

☞ P. 47, "Getting Ready to Receive Data from a Computer"

### Is **PAUSE** illuminated?

When **PAUSE** lights up, operation is paused. To resume, press **PAUSE**. **PAUSE** goes dark and outputting resumes.

☞ P. 49, "Pausing and Canceling Output"

### Has ink run out?



1\_2 3 4 5 6 7 8

When printing data is sent while the screen shown in the figure is displayed, a message appears and a warning beep sounds. At the same time, operation pauses. When the ink cartridge is replaced with a new one, printing or cutting starts.

☞ P. 54, "How to Replace Ink Cartridges"

☞ P. 125, "Determining What Happens When Ink Runs Out"

---

### Is a message displayed on the screen?

---

- ☞ P. 152, "A Message Appears"
- ☞ P. 154, "An Error Message Appears"

---

### Is the cable connected?

---

Connect the cable securely.

- ☞ "Setup Guide"

---

### Is the network routing appropriate?

---

Try connecting the computer and the machine to the same hub, or connecting them directly using a crossover cable. If this makes it possible to perform output, it means the problem is in the network itself.

---

### Are the network settings correct?

---

If the cable connections are secure and no problem is found in the network itself, make sure that the IP address and other such settings are appropriate. The settings on both the machine and the computer must be appropriate. Redo the settings, checking to ensure that the IP address doesn't conflict with the IP address for another device on the network, that the port setting for the software RIP specifies the IP address set on the machine, that the settings have no typing errors, and for other such problems.

- ☞ "Setup Guide"
- ☞ P. 130, "Viewing Information about the System of This Machine"

---

### Did the software RIP end abnormally?

---

Make sure the software RIP is running correctly, then switch the sub power switch off and back on.

- ☞ "Roland VersaWorks Dual Installation Guide"

## The Media Take-up System Doesn't Run

---

### Is the cable connected?

---

Connect the cable for the take-up unit to the machine. To perform take-up automatically during printing, also make the setting for the AUTO switch.

- ☞ "Setup Guide"
- ☞ P. 118, "How to Take Up Media"

---

## The Media Heating System Doesn't Warm Up

---

### Is media loaded?

---

The media heating system does not warm up to the preset temperature when **SET UP** is dark (by default). Load media and wait for the machine to warm up.

☞ P. 85, "Fully Utilize the Media Heating System"

---

### Is the temperature of the room too low?

---

Use the machine in an environment where the temperature is 20 to 32°C (68 to 90°F).

## Cannot cut off the media

---

### Is the separating knife mounted?

---

If the separating knife is not mounted, you cannot cut off the media.

☞ P. 76, "Replacing the Separating Knife"

## Cannot select "EDGE" and "PIECE".

---

### Is "EDGE DETECTION" set to "DISABLE"?

---

If "EDGE DETECTION" is set to "DISABLE", the front edge and trailing edge of the media cannot be detected, and consequently "EDGE" and "PIECE" cannot be selected in "SETUP SHEET". To select "EDGE" or "PIECE", set "ENABLE" to "EDGE DETECTION".

☞ P. 95, "Using Transparent Media"

# Attractive Printing or Cutting is Impossible...

## Printed Results Are Coarse or Contain Horizontal Stripes

---

### Does the print heads show dot drop-out?

---

Carry out a printing test and make sure no dot drop-out occurs. If dot drop-out is present, perform head cleaning.

- ☞ P. 43, "Printing Tests and Normal Cleaning"
- ☞ P. 59, "When Normal Cleaning Is Not Effective"

---

### Is the head height appropriate?

---

Printing when the [HEAD HEIGHT] menu item is set to "HIGH" is coarser than when set to "LOW." Keep this set to "LOW" except when changing it is necessary, such as when you're using thick media.

- ☞ P. 94, "Adjusting Head Height to Match Media Thickness"

---

### Have you carried out feed correction?

---

Large misalignment in the amount of feed of the media may result in printing that seems coarse or contains horizontal stripes. Either make the setting on the computer to match the type of media you're using, or make the setting for correction on the printer.

- ☞ P. 92, "Alleviating Horizontal Bands and the Like (feed correction function)"

---

### Have you carried out bidirectional correction?

---

When you are performing bidirectional printing, use the [ADJUST BI-DIR] menu item to carry out correction. The optimal adjustment value may vary, depending mainly on the thickness of the media. Set or select an adjustment value that is suited to the media. When further correction is required, such as when adjustment made using [SIMPLE SETTING] does not enhance printing, use [DETAIL SETTING] to make correction.

- ☞ P. 91, "Correcting for Misalignment in Bidirectional Printing"
- ☞ P. 92, "Correcting for Misalignment in Bidirectional Printing More Precisely"

---

### Is the media heating system at a suitable temperature?

---

If the ink forms lumps or smudges, raise the temperature. Note, however, that a temperature that is too high may degrade the media or cause it to wrinkle.

- ☞ P. 85, "Fully Utilize the Media Heating System"

---

### Is the temperature of the room too low?

---

The media heating system may not warm up sufficiently when the ambient temperature is less than 20°C (68°F). Also, even when the media heating system reaches its preset temperatures, adequate effectiveness may not be apparent if the media is thoroughly chilled. Before printing, allow the media to come to room temperature.

---

### Is the print mode suitable?

---

If attractive printing is impossible even when the media heating system is at a high temperature, try using a higher-quality print mode. Depending on the media, smudging may occur when using a high-quality print mode, and results may also vary greatly depending on the settings of your software RIP (such as the colorprofile selection). Make settings suited to the media you're using.



---

**Is the printer installed in a level and stable location?**

---

Never install the machine in a location where it is tilted or where it may wobble or experience vibration. Also make sure that the print heads are not exposed to moving air. These factors may lead to missing dots or reduced printing quality.

---

**Is the media loaded and set up correctly?**

---

If the media is not loaded and set up correctly, media feed may not be smooth, or printing may be adversely affected. Make sure the media is loaded and set up correctly.

☞ P. 148, "Media Feed Is Not Smooth"

---

**Are the settings for the [PRESET] menu item appropriate?**

---

If the settings selected with the [PRESET] menu item are not suitable for the type of media, printing may be adversely affected. Choose settings optimized to the media you're using.

☞ P. 31, "Setup of Media ([Media Setting] menu)"

☞ P. 82, "Fully Utilizing Preset Function"

## Colors Are Unstable or Uneven

---

**Did you shake the ink cartridges gently before in-stalling them?**

---

Shake new cartridges gently before you install them.

---

**Is the media wrinkled?**

---

If the media is wrinkled and comes loose from the platen, colors may be uneven or printing quality may suffer.

☞ P. 148, "Media Feed Is Not Smooth"

---

**Was printing paused partway through?**

---

When printing is paused, the coloring at the seam may be altered when printing resumes. Avoid pausing printing. By default, printing pauses when ink remaining inside the machine runs out. Before you perform lengthy printing, check the amount of ink remaining in the ink cartridges. Printing may also pause when data is not sent from the computer quickly enough. We recommend not performing any other tasks with the computer while printing is in progress.

---

**Is the printer installed in a level and stable location?**

---

Never install the machine in a location where it is tilted or where it may wobble or experience vibration. Also make sure that the print heads are not exposed to moving air. These factors may lead to missing dots or reduced printing quality.

---

### Is the media loaded and set up correctly?

---

If the media is not loaded and set up correctly, media feed may not be smooth, or printing may be adversely affected. Make sure the media is loaded and set up correctly.

☞ P. 148, "Media Feed Is Not Smooth"

---

### Are the operating parameters set to appropriate values?

---

Depending on the settings for such menu items as [FULL WIDTH S] and [PERIODIC CL.], uneven colors may occur. If the settings have been changed, try restoring them to their default values.

☞ P. 97, "Speeding Up Output for Narrow Media"

☞ P. 98, "Preventing Soiling of the Media and Dot Drop-out"

---

### Are the settings for the [PRESET] menu item appropriate?

---

If the settings selected with the [PRESET] menu item are not suitable for the type of media, printing may be adversely affected. Choose settings optimized to the media you're using.

☞ P. 82, "Fully Utilizing Preset Function"

## The Media Becomes Soiled When Printed

---

### Does the print heads contact the media?

---

The height of the print heads may be too low. Also, if the media is not loaded and set up correctly, it may wrinkle or come loose and strike the heads

☞ P. 94, "Adjusting Head Height to Match Media Thickness"

☞ P. 147, "Media Feed is Not Smooth"

---

### Are the print heads dirty?

---

The following may cause ink to drip on the media during printing.

- **Buildup of fibrous dust (lint) around the heads.**
- **Ink transferred to the heads due to rubbing against the media.**

If this happens, clean the print heads manually. We recommend carrying out periodic head cleaning.

☞ P. 61, "Manual Cleaning of Print Heads"

- **Tow Low Humidity.**

Use this machine in the environment of 35 to 80 %RH (no condensation).

---

### Are the pinch rollers or the media clamps dirty?

---

Periodically clean them.

☞ P. 57, "Cleaning"

## Cutting Is Misaligned or Skewed

### Is the media loaded and set up correctly?

If the media is not loaded and set up correctly, or media feed is not smooth, cutting may be adversely affected. Make sure the media is loaded and set up correctly.

☞ P. 148, "Media Feed Is Not Smooth"

### Are the settings for the cutting conditions appropriate?

Misalignment or skewing may occur if the cutting speed is too fast or the blade force is too high. Try changing the cutting conditions. With media having a strong adhesive layer, the adhesive layer reattaches to itself immediately after cutting. However, if a cutting test shows that the peeling of the media and the blade traces on the backing paper are optimal, then the media is being cut properly. Be careful not to make the blade force too high.

☞ P. 82, "Fully Utilizing Preset Function"

### Is the length of output too long?

For printing followed immediately by cutting in particular, the longer the page length (that is, the longer the distance the media is returned after printing), the greater is the chance of misalignment occurring. It is a good idea to keep the size of each single page to the minimum necessary.

### Are you using media that exhibits large expansion and contraction?

When you're performing printing followed immediately by cutting, misalignment occurs if the media expands or contracts. If this happens, try performing printing with crop marks, then setting the base point and one or more align points and performing cutting. This corrects for expansion and contraction of the media.

### Is [AUTO ENV. MATCH] set to the "DISABLE" setting?

The printing and cutting positions may become misaligned due to ambient temperature or humidity. Setting [AUTO ENV. MATCH] to "ENABLE" performs matching to the environment to correct for misalignment.

☞ P. 108, "Viewing the Automatic Environment Correction Function Settings"

### Are the settings for the [CALIBRATION] menu item (in the [CUTTING MENU] menu item) correct?

When you're performing printing followed immediately by cutting, go to [CUTTING MENU] and set the [CALIBRATION] value to "0.00."

☞ P. 104, "Performing Distance Correction During Cutting"

### Are the pinch rollers placed on the proper locations?

Be sure to place the pinch Rollers on the grit rollers. If the pinch rollers are not placed on the proper locations, misalignment of the media may occur.

☞ P. 19, "Loading Media"

# Media Jam Occurs!

## The Media Jams

---

**If an error message is displayed because the media has jammed, immediately correct the problem. Failure to do so may damage the print heads.**

---

☞ P. 157, "[MOTOR ERROR TURN POWER OFF]"

---

### **Is the media warped or wrinkled?**

---

Many factors can cause warping or wrinkling. Refer to the following and correct the problem.

☞ P. 148, "Media Feed Is Not Smooth"

---

### **Is the height of the print heads too low?**

---

Try raising the heads higher. Media may inevitably warp or wrinkle slightly, so adjust the height of the heads to take this into account.

☞ P. 94, "Adjusting Head Height to Match Media Thickness"

# Media Feed is Not Smooth

A variety of problems can occur if the media feed is not smooth. This can cause such problems as poor printing quality, contact with the media by the print heads, misaligned positioning, or media jams. Take action as follows.

## Media Wrinkles or Shrinks

---

### Is the media loaded and set up straight and securely?

---

Feed is not smooth when the media is not straight or is tensioned unevenly on the left and right. Reload the media.

☞ P. 31, "Setup of Media ([Media Setting] menu)"

---

### Was loaded media allowed to stand for some time?

---

Media may shrink or wrinkle if it is heated for an extended time. When printing ends, switch off the sub power or remove the media.

---

### Are the media clamps mounted?

---

When you're performing printing, be sure to attach the media clamps.

---

### Was the media loaded while the print heater was hot?

---

Loading media after the print heater has warmed up causes the temperature of the media to rise suddenly, which may cause the media to shrink or wrinkle during printing. Before loading media, switch off the sub power and allow the platen to cool.

☞ P. 85, "Fully Utilize the Media Heating System"

---

### Is the temperature of the media heating system too high?

---

Set the temperature to suitable values for the type of media.

☞ P. 85, "Fully Utilize the Media Heating System"

---

### Is the temperature of room too low?

---

Use this machine in an environment having an ambient temperature of 20 to 32°C (68 to 90°F). If the machine is used at an ambient temperature less than 20°C, then depending on the type or width of the media, wrinkling or temperature-caused unevenness may occur. If this happens, try lowering the temperature of the media heating system by about 2°C. To obtain stable printing results, however, the machine should be used at an ambient temperature of 20 to 32°C(68 to 90°F).

---

### Is the humidity of the room too high?

---

Use this machine in the environment of 35 to 80 %RH (non condensation).

---

### Is the using media deflected?

---

If using the deflected media, it cause wrinkle of the media.

## Media Feed Is Not Straight

---

### Is the media loaded and set up straight and securely?

---

Feed is not smooth when the media is not straight or is tensioned unevenly on the left and right. Reload the media.

☞ P. 31, "Setup of Media ([Media Setting] menu)"

## Media Feed Is Not Smooth

---

### Do the media or the shafts strike some other object?

---

Make sure the media and the shafts do not touch anything else. This may affect output, even when feed appears to be smooth.

☞ P. 31, "Setup of Media ([Media Setting] menu)"

---

### Is the media too thick?

---

Media that is too thick may not only cause unstable feed, but may scrape the print heads, resulting in malfunction. Never use such media.

---

### Are the grit rollers dirty?

---

Check to make sure the grit rollers are free of buildup of foreign material such as media scraps.

☞ P. 57, "Cleaning"

# The Media Cannot Be Taken Up Smoothly

## The Media Cannot Be Taken Up Smoothly

---

### Is media feed unstable?

---

Various factors can make media feed unstable. Refer to the following and correct the problem.

☞ P. 148, "Media Feed Is Not Smooth"

---

### Is the paper tube installed correctly?

---

Securely insert the paper tube onto the end caps. If the paper tube is not attached correctly, it may spin without traction and fail to take up the media.

☞ "Setup Guide"

---

### Is the paper tube bent or sagging?

---

Media cannot be taken up smoothly when the paper tube is bent or sagging.

---

### Are you using the included paper tube?

---

For the paper tube, use the included item. Using something other than the included item may result in spinning without traction or other problems that impede media take-up.

☞ P. 118, "About the Paper Tube"

# Print Heads Stop Moving. Why?

If the print-head carriage stops over the platen, take action immediately to prevent the heads from drying out.

## What to Do First

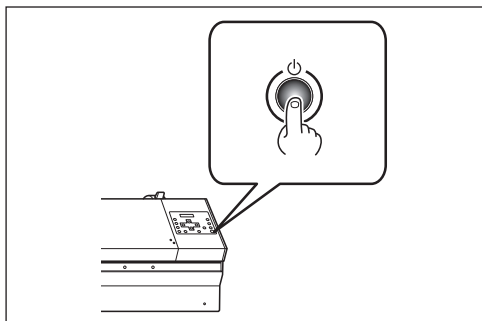

Switch the sub power off, then back on again.

If the media is jammed, then also remove the media.

If the print-head carriage move to the stand-by position (inside the cover R), it means the operation has ended successfully.

---

### If The Print Heads Still Do Not Move

---

Try switching off the main power, then again switching on the main power, followed by the sub power.

## If the Print Heads Still Do Not Move

If the print heads still do not move, carry out the following emergency response measure, then contact your authorized Roland DG Corp. dealer.

### Procedure

---

**1** Switch off the main power and open the front cover.

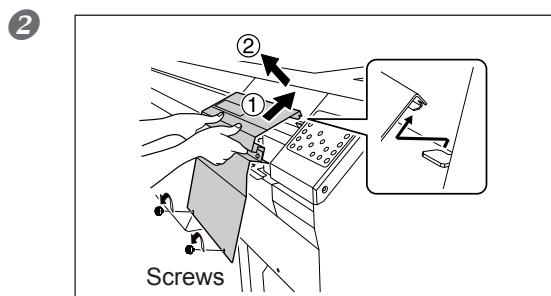

**Remove the Cover R.**

Remove the screws, lift the cover R in the direction of ① and then pull it out in the direction of ②.

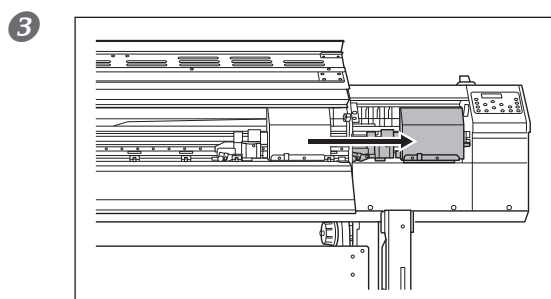

**Gently move the print head carriage to the standby position.**

Stopping at the place where the audible click is heard locks the print heads in place.



4

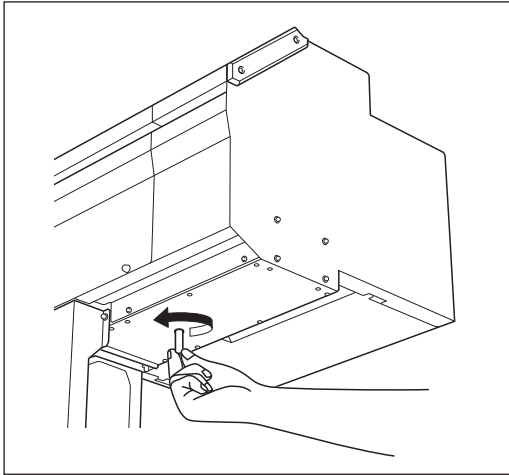

Insert the cap-unit tool into the hole at the bottom of the machine and turn gently. The cap unit rises.

5

- ① Move the print head carriage manually to align the mark with the cap unit guide.
- ② Turn the tool further to bring the cap unit near the heads.

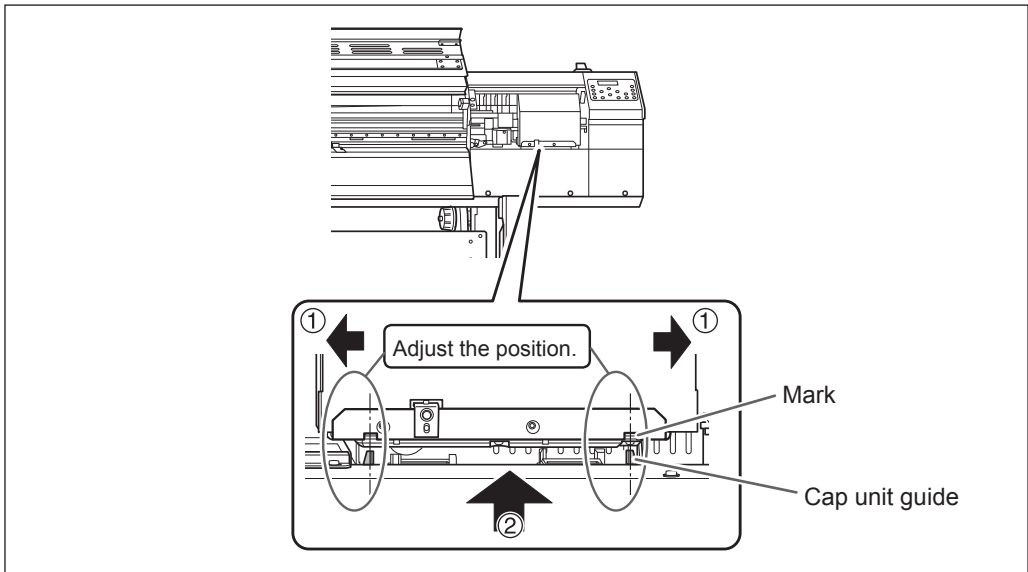

6

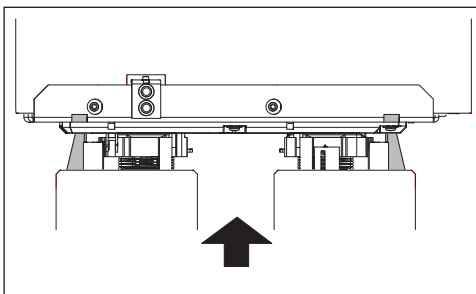

When the print heads make contact with the cap unit, turn the cap-unit tool one or two turns more.

Make sure the print heads are capped tightly.

# A Message Appears

These are the main messages that appear on the machine's display to prompt correct operation. They do not indicate any error. Follow the prompts and take action accordingly.

---

## [ 1 ■ 2 ■ 3 ■ 4 ■ 5 ■ 6 ■ 7 ■ 8 ■ ]

---

Only a small amount of ink remains. Replace the cartridge indicated by the flashing number with a new cartridge. (The display varies according to the number of ink cartridge slots in use.)

---

## [PRESS THE POWER KEY TO CLEAN]

---

This appears when the machine has been unused for about one month. Switch on the sub power once a month.  
☞ P. 78, "When Not in Use for a Prolonged Period"

---

## [CLOSE THE COVER (FRONT COVER, COVER L or COVER R)]

---

Close the front cover, cover L, or cover R. For safety, the carriage does not operate while a cover is open.

---

## [SHEET NOT LOADED PRESS SETUP KEY]

---

Load media. This message appears when an attempt to perform a printing test was made while no media was loaded.

---

## [END OF THE SHEET]

---

The trailing edge of the media was detected during operation. Press any button on the operation panel to clear the message. Load new media.

---

## [CHECK DRAIN BOTTLE]

---

This appears when a certain amount of discharged fluid collects in the drain bottle. To clear the message, press **ENTER**. If this screen appears, go to the [DRAIN BOTTLE] menu and discard the discharged fluid in the bottle.  
☞ P. 55, "Disposing of Discharged Fluid"

---

## [INSTALL DRAIN BOTTLE]

---

Check whether the drain bottle is installed. Install the drain bottle, then press **ENTER**.  
☞ P. 55, "Disposing of Discharged Fluid"

---

## [NOW HEATING...]

---

Wait until the media heating system reaches the preset temperature. Printing starts when **HEATER CONFIG** lights up. You can stop printing by holding down **SET UP** for one second or longer while this is displayed. Pressing **PAUSE** makes printing start immediately, without waiting to reach the preset temperature.

---

## [REMOVE MEDIA CLAMPS]

---

This appears if **SHEET CUT** is pressed while the media clamps are attached. Remove the media clamp and press **ENTER**.

---

**[TIME FOR MAINTENANCE]**

---

It is time to clean the printer heads manually. After verifying, press **ENTER**. If this message is displayed, be sure to perform manual cleaning.

- ☞ P. 62, "Manual Cleaning of Print Heads"

---

**[TIME FOR WIPER (FELT) REPLACE]**

---

It is time to replace the wiper or felt wiper. After verifying, press **ENTER**.

- ☞ P. 68, "Replacing the Wiper"
- ☞ P. 71, "Replacing the Felt Wiper"

---

**[OPEN THE VALVE]**

---

Open the valve. The valve described here is the part you handle when you clean heads to perform the first ink filling after purchasing this machine. Do not operate this except when filling ink for the first time and "Selecting the ink type". If you try to close the valve in an undesirable manner, it may cause troubles including NG ink discharge.

- ☞ "Setup Guide"
- ☞ P. 132, "How to change the ink type"

# An Error Message Appears

This describes the error messages that may appear on the machine's display, and how to take action to remedy the problem. If the action described here does not correct the problem, or if an error message not described here appears, contact your authorized Roland DG Corp. dealer .

---

## [ALIGN POINT POSITION INVALID]

---

**An attempt was made to set an align point at a location where the setting cannot be made.** No align point can be set when the angle of the base point and the align point is too large. Reload the media correctly, so that the angle is minimized, then set the base point and the align point again to match the crop marks.

☞ P. 109, "Performing Printing and Cutting Separately"

---

## [OPTION-DRYER IS NOT CONNECTED]

---

When the drying-heater unit is not connected to the printer, [OPTION DRYER] is set to "ENABLE." Switch the sub power and main power off, and then connect the drying-heater unit to the printer.

---

## [HEATING TIMEOUT CONTINUE?]

---

**The print heater or dryer did not reach the preset temperature.**

This occurs because the temperature of the location where the machine is installed is too low. We recommend raising the temperature. To continue waiting for the temperature to rise, press **ENTER** . To start printing immediately, press **PAUSE** .

---

## [CARRIAGES ARE SEPARATED]

---

**The cutting carriage and the print-head carriage were improperly disconnected.**

A problem such as a media jam occurred, impeding correct operation. Operation cannot be continued. Switch the sub power off, then back on.

---

## [CROPMARK ERROR NOT FOUND]

---

**Automatic detection of crop marks could not be accomplished.**

Load the media at the correct position and perform detection of crop marks again. Depending on the media, it may not be possible to detect crop marks automatically. If repeating automatic crop-mark detection results in an error again, then perform manual crop-mark detection.

☞ P. 109, "Performing Printing and Cutting Separately"

---

## [CAN'T PRINT CROP CONTINUE?]

---

**The size of the data including the crop marks is larger than the printing or cutting area of the loaded media.**

To continue performing output without correcting this, press **ENTER** . At this time, the portion extending beyond the printing or cutting area and the crop marks are not printed. To stop output, stop sending data from the computer, then raise the loading lever. Make the printing or cutting area wider, such as by replacing the media with a larger piece of media or by changing the positions of the pinch rollers, then send the data again.

**The size of the data being output is too small.**

Make the scanning-direction size of the data at least 65 mm (2.6 in). To continue performing output without correcting this, press **ENTER**. At this time, the data is output without printing the crop marks. To stop output, stop sending data from the computer, then raise the loading lever. Change the size of the data, then send the data again. There is no limitation in the size of the data in the media-feed direction.

**[TEMPERATURE IS TOO HIGH \*\*°C]****The temperature of the location where the machine is installed has risen above the ambient temperature at which the machine can operate.**

Operation cannot be continued. Switch off the sub power. The displayed temperature is the current ambient temperature of the installation location. Bring the installed location to a temperature at which operation is possible (15 to 32°C) and allow the machine to come to room temperature, then turn on the power.

**[TEMPERATURE IS TOO LOW \*\*°C]****The temperature of the location where the machine is installed has fallen below the ambient temperature at which the machine can operate.**

Operation cannot be continued. Switch off the sub power. The displayed temperature is the current ambient temperature of the installation location. Bring the installed location to a temperature at which operation is possible (15 to 32°C) and allow the machine to come to room temperature, then turn on the power.

**[SERVICE CALL xxxx]****An unrecoverable error occurred, or part replacement that must be performed by a service technician is required.**

Note the number displayed, then switch off the sub power. After you switch off the power, inform your authorized Roland DG Corp. dealer of the number that appeared on the display.

**[SHEET TOO SMALL CONTINUE?]****The size of the data is larger than the printing or cutting area of the loaded media.**

To continue performing output without correcting this, press **ENTER**. At this time, the portion extending beyond the printing or cutting area is not output. To stop output, stop sending data from the computer, then raise the loading lever. Make the printing or cutting area wider, such as by replacing the media with a larger piece of media or by changing the positions of the pinch rollers, then send the data again.

**[SHEET SET ERROR SET AGAIN]******SET UP** was pressed even though no media is loaded.**

Press any key to clear the error. Load media and pull back the loading lever, then press **SET UP**.

☞ P. 19, "Loading Media"

**[EDGE DETECTION] is set to "ENABLE," but transparent media was loaded.**

Raise the loading lever, set the [EDGE DETECTION] menu item to "DISABLE," then reload the media.

☞ P. 95, "Using Transparent Media"

**The loaded media is too small.**

Press any key to clear the error. Replace with media of usable size.

---

### [SETUP SHEET AGAIN]

---

The media setup is canceled because two or more of the following conditions are present.

- "EDGE" or "PIECE" is selected in [SETUP SHEET], where media setup is done.
- "AUTO DISPLAY" is set to "ENABLE" (the screen for loading a preset is displayed at the time of media setup).
  - ☞ P. 84, "Automatic loading of a saved preset when media is loaded"
- In the loaded preset, "EDGE DETECTION" is set to "DISABLE" (detection of the leading and trailing edges of the media is disabled).
  - ☞ P. 95, "Using Transparent Media"

When "EDGE DETECTION" is set to "DISABLE," you cannot select "EDGE" or "PIECE" in [SETUP SHEET]. For this reason, the setting is canceled if two or more of the above conditions are present. If you want to select "EDGE" or "PIECE," call a preset for which "ENABLE" has been selected for [EDGE DETECTION], or set [EDGE DETECTION] to "ENABLE" before [SETUP SHEET].

---

### [DATA ERROR CANCELING...]

---

**Output was stopped because a problem was found in the data received.**

Operation cannot be continued. Check for a problem with the connector cable or the computer, and redo the operation from the step of loading the media.

---

### [PINCHROLL ERROR INVALID LEFT(RIGHT) POS]

---

**The left (right) pinch roller is positioned at a location where it does not pinch the media.**

First, move the loading lever to the rear and move the left (right) pinch roller to the correct location.

☞ P. 19, "Loading Media"

---

### [PINCHROLL ERROR LOWER PINCHROLL]

---

**SET UP was pressed without first lowering the pinch rollers.**

Press any key to clear the error. Pull back the loading lever, then press SET UP.

**The pinch rollers were raised while SET UP was illuminated.**

The error is cleared automatically after a short wait. Never move the loading lever while printing is in progress.

---

### [WRONG CARTRIDGE]

---

**A cartridge that cannot be used was installed.**

Remove the cartridge to clear the error. Use a cartridge of the specified type.

---

**[AVOIDING DRY-UP TURN POWER OFF]**

---

**The print heads were forced to standby position to prevent them from drying out.**

Operation cannot be continued. Switch the sub power off, then back on.

---

**[SET HEAD HEIGHT TO xxx]**

---

**The height of the print head is lower than the height specified on the software RIP.**

This warning indicates that the height of the print heads is too low for the media thickness specified on the software RIP. The heads move to a location where you can operate the height-adjustment lever. Adjust to the displayed height, then press **ENTER**.

☞ P. 94, "Adjusting Head Height to Match Media Thickness"

---

**[MOTOR ERROR TURN POWER OFF]**

---

**A motor error occurred.**

Operation cannot be continued. Switch off the sub power. Next, eliminate the cause of the error, then immediately switch on the sub power. If the machine is allowed to stand with the error uncorrected, the print heads may dry out and become damaged.

This error may be caused by such factors as a mistake in loading the media, a media jam, or an operation that pulls the media with excessive force.

**The media has jammed.**

Carefully remove the jammed media. The print heads may also be damaged. Perform head cleaning, then perform a printing test and check the results.

**The media was pulled with excessive force.**

Excessive tension was applied to the media, and additional action is necessary to recover from this state. First, move the loading lever to the rear and adjust the media to create a small amount of slack, then switch on the sub power.

---

**[WRONG HEAD IS INSTALLED]**

---

**An unusable print head is installed.**

Switch off the sub power. After you switch off the power, inform your authorized Roland DG Corp. dealer.

---

**[CANCELED FOR MOTOR PROTECTION]**

---

**You started one of the following operations or menu items and, within 10 minutes, tried to start another.**

- **Ink filling at the time of installing this machine or changing ink type.**
- **PUMP UP**
- **HEAD WASH**

Press any key other than the sub power switch to cancel the error message. Allow the machine to stand for approximately 10 minutes before resuming operation. These menu items require the pump motor to turn for a long time. When performing these menu items in a row, take an interval of at least 10 minutes to prevent damage to the machine due to the overheating of pump motor.

# Chapter 7

## Main Specifications

---

|  |     |
|--|-----|
| Printing / Cutting Area .....                                | 159 |
| Maximum Area.....  | 159 |
| Maximum Area When Using Crop Marks .....                     | 159 |
| The Media-cutoff Location During Continuous Printing .....   | 160 |
| About the Blade .....  | 161 |
| Locations of the Power Rating and Serial Number Labels ..... | 162 |
| Specifications.....  | 163 |



# Printing / Cutting Area

## Maximum Area

The printing or cutting area along the horizontal plane (the direction in which the carriages move) is determined by the position of the pinch rollers.

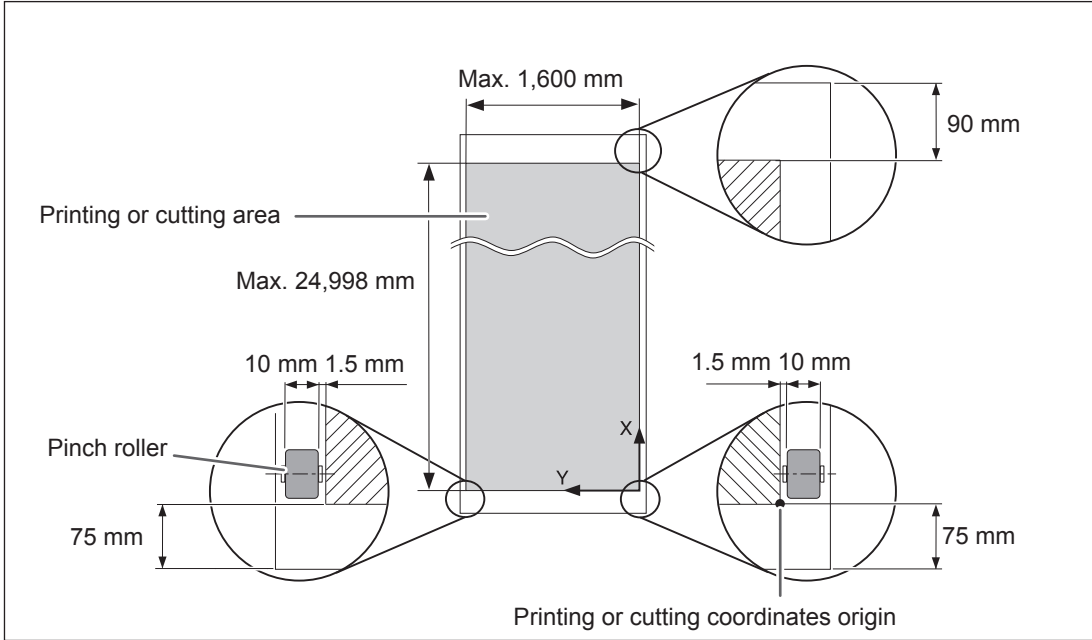

## Maximum Area When Using Crop Marks

When crop marks are used, the printing or cutting area is reduced from the maximum area by an amount equal to the crop marks.

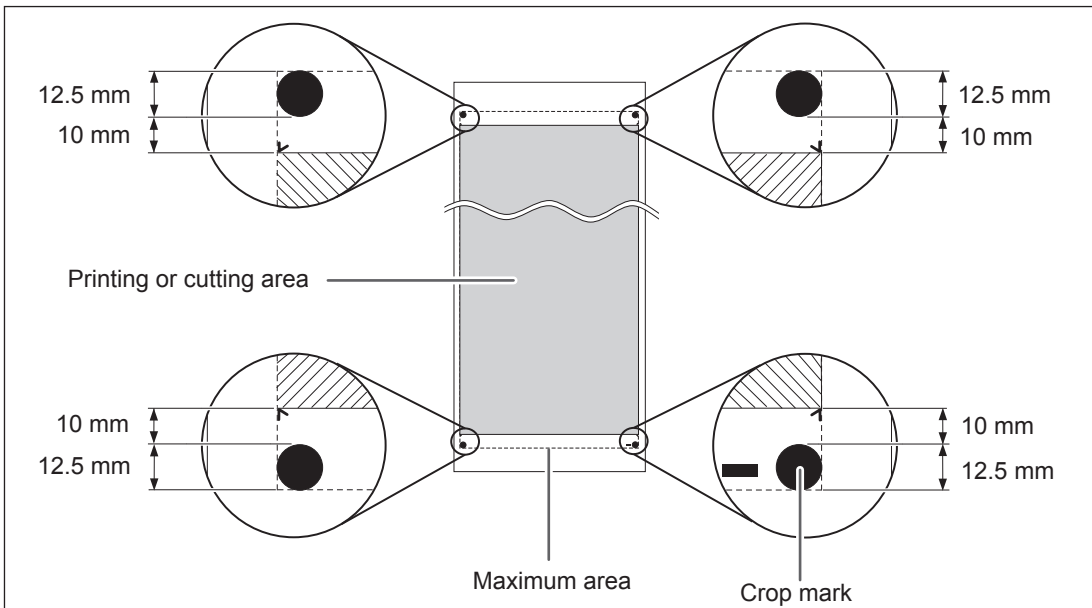

## The Media-cutoff Location During Continuous Printing

When a media-cutoff command is sent from the computer, the cutoff location on the media is as shown in the figure below.

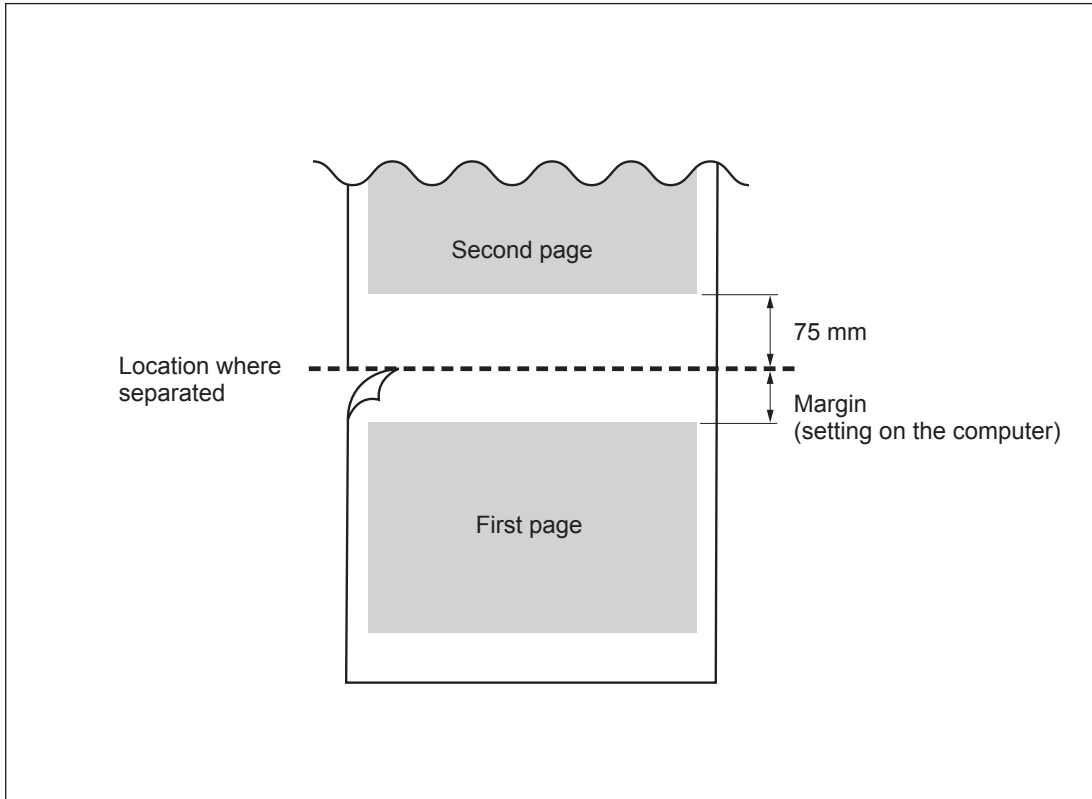

# About the Blade

The cutting conditions and the service life of the blade change according to the media and the operating environment, even when you're using identical blades. The service life also differs according to the type of blade. A rough guide is shown below.

| Blade     | Media                 | Blade force   | Amount of blade offset | Blade life* (general guide) |
|-----------|-----------------------|---------------|------------------------|-----------------------------|
| ZEC-U5022 | General signage vinyl | 30 to 100 gf  | 0.25 mm                | 8000 m                      |
| ZEC-U5025 | General signage vinyl | 30 to 100 gf  | 0.25 mm                | 4000 m                      |
|           | Fluorescent vinyl     | 120 to 200 gf | 0.25 mm                | 4000 m                      |
|           | Reflective vinyl      | 100 to 200 gf | 0.25 mm                | 4000 m                      |

When uncut areas remain even when the blade force is increased to a value that is higher by 50 to 60 gf than the values shown in this chart, then replace the blade.

\*The values for "Blade life" are estimates for when an identical type of media is used.

# Locations of the Power Rating and Serial Number Labels

## Serial Number

This is required when you seek maintenance, servicing, or support. Never peel off the label or let it get dirty.

## Power Rating

Use an electrical outlet that meets the requirements for voltage, frequency, and amperage given here.

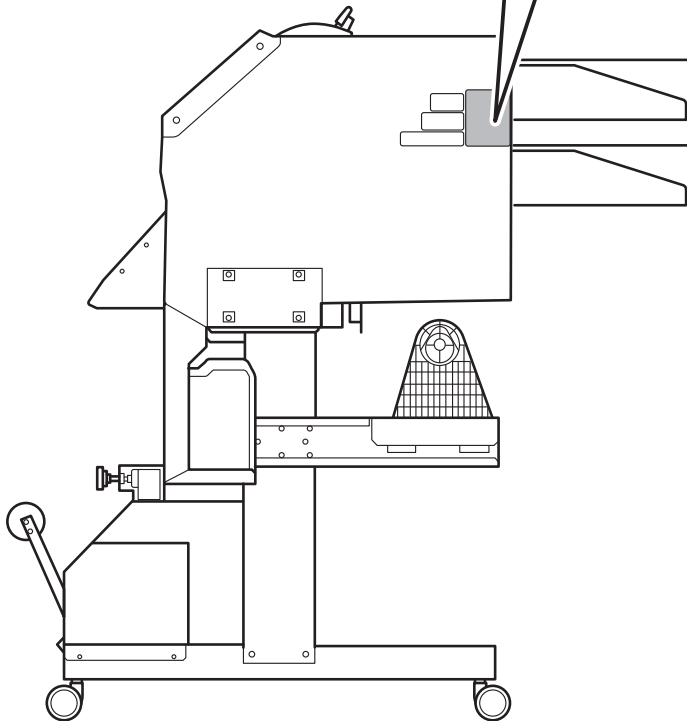

# Specifications

|  |                            | XR-640  |  |
|--|----------------------------|---|--|
| <b>Printing/cutting method</b>   |                            | Piezo ink-jet method/media-moving method  |  |
| <b>Media</b>   | <b>Width</b>               | 315 to 1,625 mm (12.4 to 64 in.)  |  |
|  | <b>Thickness</b>           | Maximum 1.0 mm (39 mil) with liner, for printing<br>Maximum 0.4 mm (16 mil) with liner and 0.22 mm (9 mil) without liner, for cutting   |  |
|  | <b>Roll outer diameter</b> | Maximum 210 mm (8.3 in.)  |  |
|  | <b>Roll weight</b>         | Max. 40 kg (88 lb.)   |  |
|  | <b>Core diameter</b>       | 76.2 mm (3 in.) or 50.8 mm (2 in.)  |  |
| <b>Printing/cutting width (*1)</b>   |                            | Max. 1,600 mm (63 in.)  |  |
| <b>Ink cartridges</b>  | <b>Types</b>               | ECO-SOL MAX 2   | 440-cc cartridge (cyan, magenta, yellow, black, light cyan, light magenta, light black)<br>220-cc cartridge (cyan, magenta, yellow, black, metallic silver, white) |
|  |                            | ECO-SOL MAX 3   | 500-cc cartridge (cyan, magenta, yellow, black, light cyan, light magenta, light black)<br>220-cc cartridge (cyan, magenta, yellow, black)                         |
|  | <b>Colors</b>              | Seven colors (cyan, magenta, yellow, black, light cyan, light magenta, light black) or,<br>Eight colors (cyan, magenta, yellow, black, light cyan, light magenta, light black, white) or,<br>Eight colors (cyan, magenta, yellow, black, light cyan, light magenta, light black, metallic silver) or,<br>Eight colors (cyan, magenta, yellow, black, light cyan, light magenta, metallic silver, white) |  |
| <b>Printing resolution (dots per inch)</b>                                       |                            | Maximum 1,440 dpi   |  |
| <b>Cutting speed</b>   |                            | 10 to 600 mm/s (Media-feed direction: 10 to 300 mm/s)   |  |
| <b>Blade force</b>   |                            | 30 to 300 gf  |  |
| <b>Cutting blade</b>   | <b>Type</b>                | Roland CAMM-1 series compatible   |  |
|  | <b>Blade offset</b>        | 0.000 to 1.500 mm(0 to 0.059 in.)   |  |
| <b>Software resolution (when cutting)</b>  |                            | 0.025 mm/step   |  |
| <b>Distance accuracy (when printing) (*2)(*3)</b>                                |                            | Error of less than $\pm 0.3$ % of distance traveled, or $\pm 0.3$ mm, whichever is greater  |  |
| <b>Distance accuracy (when cutting) (*2)</b>                                     |                            | Error of less than $\pm 0.4$ % of distance traveled, or $\pm 0.3$ mm, whichever is greater<br>When distance correction has been performed (when the setting for [CUTTING MENU] - [CALIBRATION] has been made): Error of less than $\pm 0.2$ % of distance traveled, or $\pm 0.1$ mm, whichever is greater   |  |
| <b>Repeatability (when cutting) (*2)(*4)</b>                                     |                            | $\pm 0.1$ mm or less  |  |
| <b>Alignment accuracy for printing and cutting (*2)(*5)</b>                      |                            | $\pm 0.5$ mm or less  |  |
| <b>Alignment accuracy for printing and cutting when reloading media (*2)(*6)</b> |                            | Error of less than $\pm 0.5$ % of distance traveled, or $\pm 3$ mm, whichever is greater  |  |
| <b>Dryer unit</b>  |                            | Heating type, setting range for the preset temperature: 30 to 55°C (86 to 130°F)  |  |
| <b>Ink-fixing device (*7)</b>  |                            | Print heater / preheater, setting range for the preset temperature: 30 to 50°C (86 to 122°F)  |  |
| <b>Connectivity</b>  |                            | Ethernet (10BASE-T/100BASE-TX, automatic switching)   |  |
| <b>Power-saving function</b>   |                            | Automatic sleep feature   |  |
| <b>Power requirements</b>  |                            | AC 100 to 120 V $\pm 10\%$ , 12 A, 50/60 Hz or AC 220 to 240 V $\pm 10\%$ , 6.5 A, 50/60 Hz   |  |

## Specifications

|                                |                         |  |
|--------------------------------|-------------------------|--|
| <b>Power</b>                   | <b>During operation</b> | Approx. 1,600 W  |
|                                | <b>Sleep mode</b>       | Approx. 47 W   |
| <b>Acoustic noise level</b>    | <b>During operation</b> | 65 dB (A) or less  |
|                                | <b>During standby</b>   | 45 dB (A) or less  |
| <b>Dimensions (with stand)</b> |                         | 2,948 (W) x 1,211 (D) x 1,260 (H) mm (116.1 (W) x 47.7 (D) x 49.6 (H) in.)   |
| <b>Weight (with stand)</b>     |                         | 205 kg (452 lb.)   |
| <b>Environment</b>             | <b>Power on (*8)</b>    | Temperature: 15 to 32°C (59 to 90°F) (20°C [68°F] or more recommended), humidity: 35 to 80%RH (non-condensing)   |
|                                | <b>Power off</b>        | Temperature: 5 to 40°C (41 to 104°F), humidity: 20 to 80%RH (non-condensing)   |
| <b>Accessories</b>             |                         | Exclusive stands, power cord, blade, blade holder, media clamps, media holder, replacement blade for separating knife, software RIP, User's Manual, etc. |

\*1

The length of printing or cutting is subject to the limitations of the program.

\*2

- Media type: Media specified by Roland DG Corp.
- Temperature: 25°C (77°F), humidity: 50%
- Roll media must be loaded correctly.
- Applicable when all pinch rollers available to the media width are used.
- Side margins: 25 mm or more for both the left and right margins
- Front margin: 35 mm or more
- Excluding expansion/contraction of the media
- Not assured when the print heater or dryer is used.
- All correction or adjustment function of this machine has been made properly.

\*3

- Print travel: 1 m

\*4

- [PREFEED] menu item must be set to "ENABLE."
- Range for assured repetition accuracy
- For media with a width exceeding 610 mm: Length 4,000 mm
  - For media with a width of 610 mm or less: Length 8,000 mm

\*5

- Provided that media length is under 3,000 mm
- Excludes the effects of slanted movement and of expansion and contraction of the media.

\*6

- Data size: 1,000 mm in the media-feed direction, 1,600 mm in the carriage-movement direction.
- No lamination
- Automatic detection of crop marks at 4 points when media is reloaded.
- During cutting, [PREFEED] menu item must be set to "ENABLE."
- Excluding possible shift caused by expansion/contraction of the media and/or by reloading the media.

\*7

- Warm-up is required after power up. This may require 5 to 20 minutes, depending on the operating environment.
- Depending on the ambient temperature and media width, the preset temperature may fail to be reached.

\*8

- Operating environment

