

# TrueVIS VG-640/VG-540 USER'S MANUAL

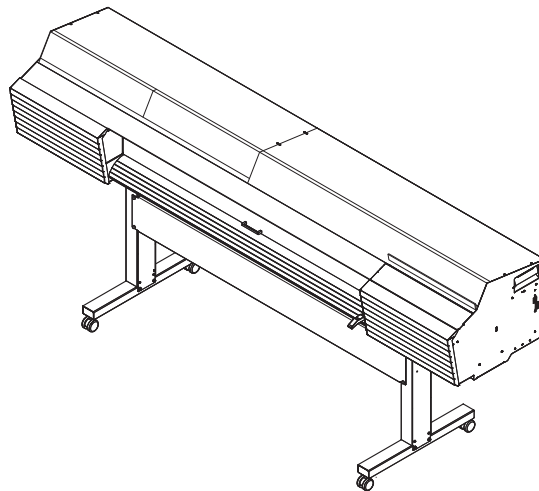

**This machine has a built-in inductive reading/writing communication device that uses radio waves (an RFID device).**

- RFID is used to read the information inscribed on the ink pouches (or cartridges).
- If you use a pacemaker or other implanted medical equipment, do not approach this machine.
- Do not use this machine within hospitals.

---

Thank you very much for purchasing this product.

- To ensure correct and safe usage with a full understanding of this product's performance, please be sure to read through this manual completely and store it in a safe location.
  - Unauthorized copying or transferral, in whole or in part, of this manual is prohibited.
  - The contents of this manual and the specifications of this product are subject to change without notice.
  - This manual and the product have been prepared and tested as much as possible. If you find any misprints or errors, please inform Roland DG Corp.
  - Roland DG Corp. assumes no responsibility for any direct or indirect loss or damage that may occur through use of this product, regardless of any failure to perform on the part of this product.
  - Roland DG Corp. assumes no responsibility for any direct or indirect loss or damage that may occur with respect to any article made using this product.
- 

Roland DG Corporation



## For the USA and Canada

### FCC CAUTION

Changes or modifications not expressly approved by the party responsible for compliance could void the user's authority to operate the equipment.

This transmitter must not be co-located or operated in conjunction with any other antenna or transmitter.

This device complies with Part 15 of FCC Rules and Industry Canada's licence-exempt RSSs. Operation is subject to the following two conditions: (1) this device may not cause harmful interference, and (2) this device must accept any interference received, including interference that may cause undesired operation.

-----  
Le présent appareil est conforme à la partie 15 des règles de la FCC et aux normes des CNR d'Industrie Canada applicables aux appareils radio exempts de licence. L'exploitation est autorisée aux deux conditions suivantes : (1) l'appareil ne doit pas produire de brouillage, et (2) l'appareil doit accepter tout brouillage subi, même si le brouillage est susceptible d'en compromettre le fonctionnement.

This equipment complies with FCC/IC radiation exposure limits set forth for an uncontrolled environment and meets the FCC radio frequency (RF) Exposure Guidelines and RSS-102 of the IC radio frequency (RF) Exposure rules. This equipment has very low levels of RF energy that is deemed to comply without maximum permissive exposure evaluation (MPE).

-----  
Cet équipement est conforme aux limites d'exposition aux rayonnements énoncées pour un environnement non contrôlé et respecte les règles des radioélectriques (RF) de la FCC lignes directrices d'exposition et d'exposition aux fréquences radioélectriques (RF) CNR-102 de l'IC. Cet équipement émet une énergie RF très faible qui est considérée comme conforme sans évaluation de l'exposition maximale autorisée (MPE).

This product uses GNU General Public License (GPL)/GNU Lesser General Public License (LGPL) software. You have the right to acquire, modify, and distribute the source code for this GPL/LGPL software. You can obtain the GPL/LGPL source code used in this product by downloading it from the following website:

<http://www.rolanddg.com/gpl/>

Roland DG Corp. has licensed the MMP technology from the TPL Group.

Copyright (c) 2012 - 2013, Murata Manufacturing Co., Ltd. All rights reserved.

Redistribution and use in source and binary forms, with or without modification, are permitted provided that the following conditions are met:

-Redistributions in binary form must reproduce the above copyright notice, this list of conditions and the following disclaimer in the documentation and/or other materials provided with the distribution.

THIS SOFTWARE IS PROVIDED BY THE COPYRIGHT HOLDERS AND CONTRIBUTORS "AS IS" AND ANY EXPRESS OR IMPLIED WARRANTIES, INCLUDING, BUT NOT LIMITED TO, THE IMPLIED WARRANTIES OF MERCHANTABILITY AND FITNESS FOR A PARTICULAR PURPOSE ARE DISCLAIMED. IN NO EVENT SHALL THE COPYRIGHT HOLDER OR CONTRIBUTORS BE LIABLE FOR ANY DIRECT, INDIRECT, INCIDENTAL, SPECIAL, EXEMPLARY, OR CONSEQUENTIAL DAMAGES (INCLUDING, BUT NOT LIMITED TO, PROCUREMENT OF SUBSTITUTE GOODS OR SERVICES; LOSS OF USE, DATA, OR PROFITS; OR BUSINESS INTERRUPTION) HOWEVER CAUSED AND ON ANY THEORY OF LIABILITY, WHETHER IN CONTRACT, STRICT LIABILITY, OR TORT (INCLUDING NEGLIGENCE OR OTHERWISE) ARISING IN ANY WAY OUT OF THE USE OF THIS SOFTWARE, EVEN IF ADVISED OF THE POSSIBILITY OF SUCH DAMAGE.

# Contents

Contents.....	1
<b>Chapter 1 Machine Highlights .....</b>	<b>5</b>
<b>Part Names and Functions .....</b>	<b>6</b>
Printer Unit.....	6
Operation Panel .....	11
⚠ Warning Labels .....	12
⚠ Vignettes d'avertissement.....	13
<b>Menu List .....</b>	<b>14</b>
Main Menu .....	14
Function Menu .....	18
Language and Unit Menu .....	19
<b>Important Notes on Handling and Use .....</b>	<b>20</b>
Printer Unit.....	20
Ink Pouches.....	21
<b>Chapter 2 Basic Operation.....</b>	<b>23</b>
<b>Power Supply Operations.....</b>	<b>24</b>
Turning the Power On .....	24
Turning the Power Off .....	25
Precautions When Operating the Power Supply.....	26
Sleep Mode (Power-saving Feature).....	26
<b>About the Media Used .....</b>	<b>27</b>
Types of Media.....	27
Conditions for Usable Media.....	27
<b>Basic Printing Method.....</b>	<b>28</b>
Printing Flow .....	28
Step 1 : Loading Roll Media (Setup of Media) .....	29
Step 2 : Initial Adjustment (Correcting for Misalignment in Bidirectional Printing).....	37
Step 3 : Batch Settings.....	39
Step 4 : Setting the Base Point .....	52
Step 5 : Printing Tests and Normal cleaning.....	53
Step 6 : Starting Output.....	56
<b>Basic Settings for Cutting .....</b>	<b>59</b>
Hints and Tips for Cutting Settings .....	59
Important Note on Cutting.....	59
Preventing Pulling of the Media with Undue Force .....	60
Setting the Cutting Test and the Blade Force .....	61
<b>Printing and Cutting with Crop Marks.....</b>	<b>63</b>
What Is Printing and Cutting with Crop Marks?.....	63
How to Print and Cut with Crop Marks.....	64
Printing and Cutting with Crop Marks: Basic Troubleshooting.....	66
<b>Ink Pouch/TR Cleaning Liquid Pouch Replacement .....</b>	<b>68</b>
Out-of-ink Warnings.....	68
Out-of-TR-cleaning-liquid Warnings .....	69
Ink Pouch Replacement.....	70
TR Cleaning Liquid Pouch Replacement.....	72
<b>Other Basic Operations .....</b>	<b>74</b>
Loading Sheet Media (Setup of Media) .....	74
Pausing and Canceling Output.....	79

Cutting Off the Media .....	79
<b>Chapter 3 Maintenance .....</b>	<b>81</b>
<b>Daily Maintenance .....</b>	<b>82</b>
Cleaning .....	82
When "EMPTY DRAIN BOTTLE" Is Displayed .....	83
Disposing of Discharged Fluid .....	84
Timing of Print Head Care and Maintenance .....	86
<b>When Normal Cleaning Is Not Effective .....</b>	<b>88</b>
Medium/Powerful Cleaning .....	88
<b>Manual Cleaning .....</b>	<b>90</b>
Manual Cleaning .....	90
<b>If Colors Are Uneven .....</b>	<b>97</b>
Mixing the Ink by Shaking the Pouch Tray .....	97
Damper Cleaning (When Uneven Color Issues Occur with White Ink) .....	97
<b>When Dot Drop-outs/Uneven Colors Are Not Fixed .....</b>	<b>100</b>
Super Cleaning .....	100
<b>Replacing Consumable Parts .....</b>	<b>104</b>
Replacing the Wiper .....	104
Cleaning the Wiper Tray and Replacing the Tray Pads .....	107
Replacing the Blade .....	111
Replacing the Separating Knife .....	114
<b>When Not in Use for a Prolonged Period .....</b>	<b>117</b>
Keep Performing Maintenance .....	117
Disposing of Discharged Fluid .....	117
<b>Chapter 4 Advanced Functions .....</b>	<b>119</b>
<b>Using Presets .....</b>	<b>120</b>
Saving the Current Settings (Preset Saving) .....	120
Loading a Saved Preset .....	122
<b>Settings for the Media Heating System .....</b>	<b>123</b>
What Is the Media Heating System? .....	123
Making the Temperature Setting for the Media Heating System .....	124
Setting the Temperature during Preheating .....	125
Drying the Trailing Edge of the Printing Area on the Dryer .....	126
Setting the Drying Time after Printing (When Only Printing) .....	127
Setting the Drying Time after Printing (When Printing and Cutting) .....	128
Using an Optional Dryer .....	129
Using a Blower-fan Unit .....	130
<b>Correction Functions .....</b>	<b>131</b>
Correcting for Misalignment in Bidirectional Printing .....	131
Correcting for Misalignment in Bidirectional Printing More Precisely .....	132
Reducing Horizontal Bands (Feed Correction Function) .....	133
<b>Configuring Settings to Match the Properties of the Media .....</b>	<b>135</b>
Adjusting Print Head Height to Match Media Thickness .....	135
Using Transparent Media .....	136
Using Hard-to-Dry Media .....	137
Using Media That Wrinkles Easily/Does Not Move Smoothly .....	138
Speeding Up Output for Narrow Media .....	139

Preventing Soiling of the Media and Dot Drop-out .....	140
Using Sticky Media.....	141
<b>Advanced Cutting Settings.....</b>	<b>142</b>
Fine-tuning the Cutting Conditions.....	142
Accurately Adjusting the Cutting-in Amount.....	144
Performing Distance Correction During Cutting.....	145
Correcting the Misalignment of the Printing and Cutting Positions.....	146
Prioritizing the Cutting Settings of This Machine over the Software RIP Settings.....	148
Viewing the Automatic Environment Correction Function Settings.....	149
Correcting the Misalignment of the Printing and Cutting Positions during Cutting.....	150
<b>Advanced Settings for Printing and Cutting with Crop Marks.....</b>	<b>152</b>
Aligning Positions Manually.....	152
Correcting Misalignment for Printing and Cutting When Using Crop Marks.....	154
<b>Using the Media Take-up Unit.....</b>	<b>157</b>
About the Media Take-Up Unit .....	157
<b>Performing Operations from Roland DG Mobile Panel.....</b>	<b>158</b>
What Is Roland DG Mobile Panel?.....	158
Downloading Mobile Panel.....	158
Using Mobile Panel.....	159
Important Notes on Using Mobile Panel.....	159
<b>Other Useful Functions .....</b>	<b>161</b>
Using the Print Light (Interior Light).....	161
Performing Printing Tests Arranged Horizontally .....	161
Using Media Flanges for Paper Tubes (Cores) with an Internal Diameter of 2 Inches.....	162
<b>Chapter 5 Administrator Menu .....</b>	<b>163</b>
<b>Output Operation Management.....</b>	<b>164</b>
Printing a System Report.....	164
Determining What Happens When Ink Runs Out .....	164
Displaying the Amount of Media Remaining.....	165
Making Sure to Verify the Setting for the Amount Remaining Every Time the Media Is Changed ...	166
Printing the Amount of Remaining Media .....	167
Thoroughly Using the Middle Pinch Rollers .....	168
<b>System Management of the Printer.....</b>	<b>169</b>
Setting the Menu Language and Units of Measurement.....	169
Turning on Bluetooth Communication .....	169
Setting the Activation Interval for Sleep Mode (Power-saving Feature).....	171
Viewing System Information .....	172
Returning All Settings to Factory Defaults .....	173
<b>When Moving the Unit.....</b>	<b>174</b>
Procedures from Preparing to Move Through Reinstalling.....	174
<b>Chapter 6 Troubleshooting .....</b>	<b>181</b>
<b>Attractive Printing or Cutting Is Impossible.....</b>	<b>182</b>
Printed Results Are Coarse or Contain Horizontal Stripes.....	182
The Media Becomes Soiled When Printed .....	183
Colors Are Unstable or Uneven.....	184
Cutting Is Misaligned or Skewed.....	185

A Media Jam Occurs! .....	186
The Media Has Jammed.....	186
Media Feed Is Not Smooth.....	187
Media Wrinkles or Shrinks.....	187
Media Feeding Is Not Straight.....	188
Media Feeding Is Not Smooth.....	188
The Print Heads Do Not Move .....	189
What to Do First .....	189
If the Heads Still Do Not Move .....	189
Other Problems .....	191
The Printer Unit Does Not Run.....	191
The Media Heating System Doesn't Warm Up .....	192
Cannot Cut Off the Media.....	192
It Is Not Possible to Check the Amount of Discharged Fluid in the Drain Bottle .....	193
Printer Cannot Be Operated from Mobile Panel .....	193
A Message Appears .....	195
An Error Message Appears.....	197
<b>Chapter 7 Appendix.....</b>	<b>201</b>
Printing Area.....	202
Maximum Area.....	202
Maximum Area When Using Crop Marks.....	202
The Media-Cutoff Location During Continuous Printing .....	203
About the Blade.....	204
Locations of the Power Rating and Serial Number Labels .....	205
Specifications.....	206

This document is the user' s manual for both the VG-640 and the VG-540. This document uses the following notations to distinguish between the models where necessary.

VG-640 — 64-inch model  
VG-540 — 54-inch model

Also, most of the figures in this document depict the VG-640.

Android™ and Google Play™ are trademarks or registered trademarks of Google Inc.  
iPhone, App Store, and iTunes are trademarks or registered trademarks of Apple Inc. registered in the U.S. and other countries.

Other company names and product names are trademarks or registered trademarks of their respective holders.

<http://www.rolanddg.com/>

Copyright © 2015-2017 Roland DG Corporation

# Chapter 1 Machine Highlights

Part Names and Functions .....	6
Printer Unit.....	6
Operation Panel.....	11
⚠ Warning Labels .....	12
⚠ Vignettes d'avertissement .....	13
Menu List .....	14
Main Menu.....	14
Function Menu.....	18
Language and Unit Menu .....	19
Important Notes on Handling and Use.....	20
Printer Unit.....	20
Ink Pouches.....	21

# Part Names and Functions

## Printer Unit

### Front

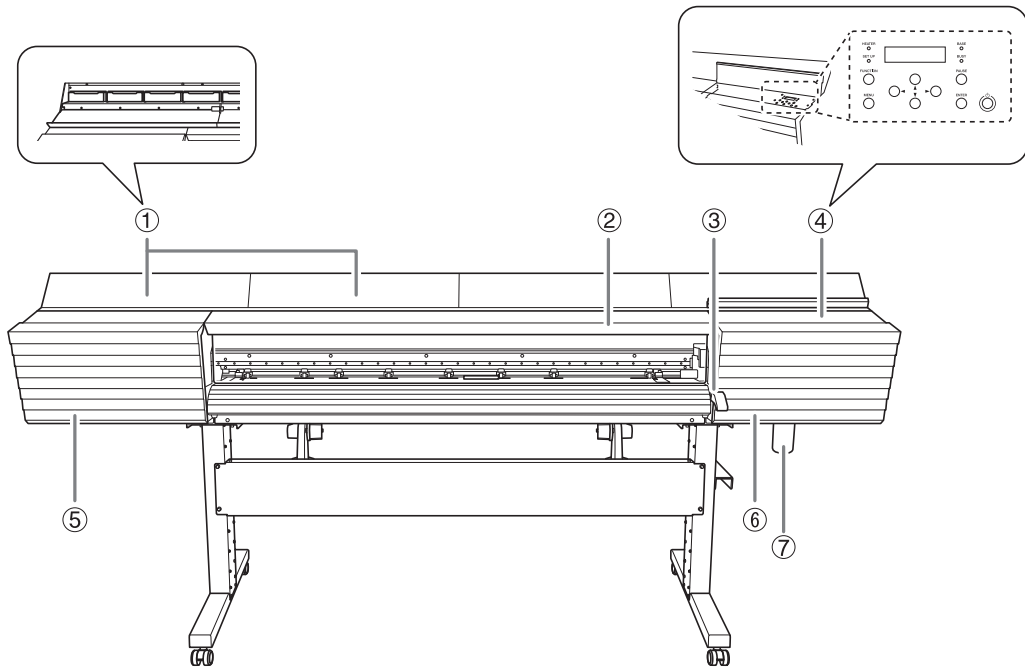

No.	Name	Function overview
①	<b>Ink slot cover, ink slots</b>	Open this cover to access the slots in which the ink trays are inserted. Leave this closed except when switching ink trays.
②	<b>Front cover</b>	Open this when necessary, such as when loading media. In all other situations, keep the front cover closed.
③	<b>Loading lever (front)</b>	Operate this when you load media.
④	<b>Panel cover, operation panel</b>	Open this cover to access the operation panel. Use the operation panel to operate this machine. ☞ P. 11 "Operation Panel"
⑤	<b>Left cover</b>	Open this when you perform maintenance.
⑥	<b>Right cover</b>	Open this when you perform maintenance.
⑦	<b>Drain bottle</b>	Discharged fluid is stored in this bottle.

**Rear**

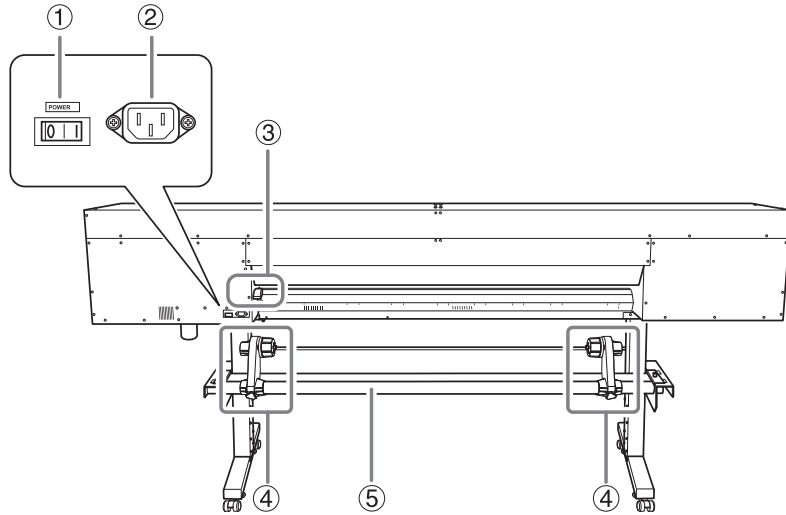

No.	Name	Function overview
①	<b>Main power switch</b>	Switch the main power on/off.
②	<b>Power-cord connector</b>	Use this to connect the power cable.
③	<b>Loading lever (rear)</b>	Operate this when you load media.
④	<b>Media holders</b>	Use these when you load media.
⑤	<b>Shafts</b>	Use these when you load media.

**Side**

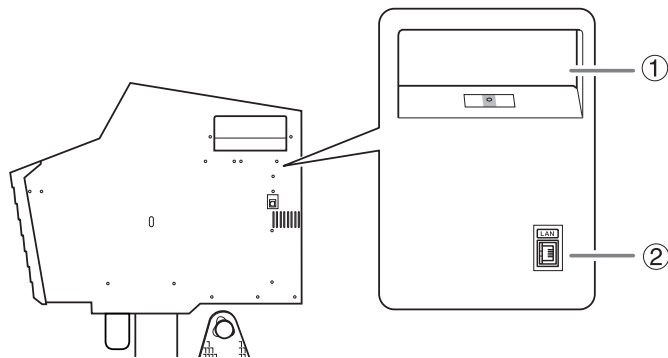

No.	Name	Function overview
①	<b>Cleaning liquid slot</b>	Insert the tray with the TR cleaning liquid pouch into this slot.
②	<b>Ethernet connector</b>	Use this to connect an Ethernet cable.

Front Cover Interior/Print Head Area

1  
Machine  
Highlights

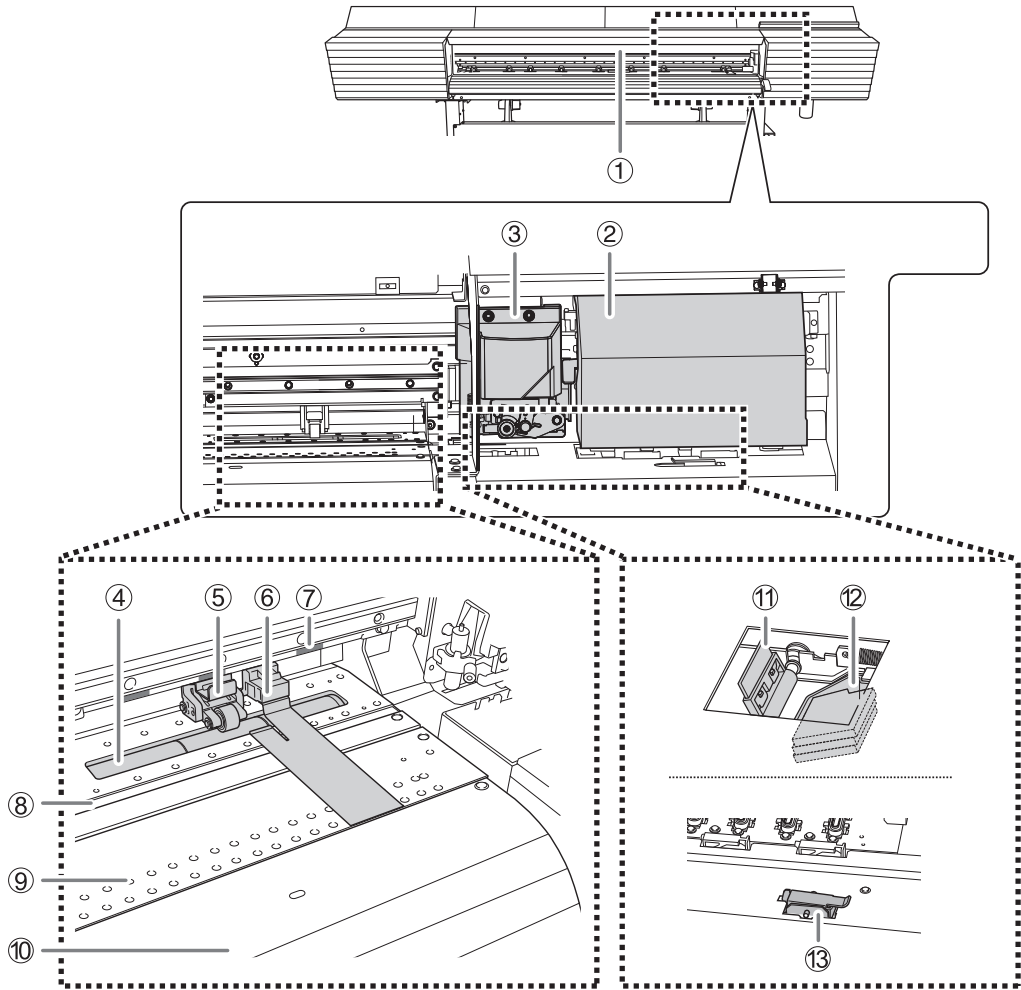

No.	Name	Function overview
①	<b>Print light</b>	This light illuminates the front cover interior. This makes it easier to see the printing status. It flashes in red if a serious error occurs. ☞ P. 9 "Serious Errors Indicated by the Print Light"
②	<b>Print-head carriage</b>	The print heads are inside here.
③	<b>Cutting carriage</b>	The blade and the separating knife are inside here.
④	<b>Grit rollers</b>	These rollers feed the media.
⑤	<b>Pinch rollers (left pinch roller, right pinch roller, and middle pinch roller)</b>	These clamp the media when the loading lever is lowered. The rollers are called the left pinch roller, the right pinch roller, and the middle pinch roller according to their positions.

No.	Name	Function overview
⑥	<b>Media clamp</b>	This clamps the edge of the media to keep it from coming loose. It also prevents fuzz on the cut edge of the media from touching the print heads.
⑦	<b>Grit patterns</b>	These indicate the locations of the grit rollers. When loading media, be sure to place the pinch rollers within the ranges indicated by these patterns.
⑧	<b>Blade protector</b>	This is the path that the blade takes during cutting. It protects the tip of the blade.
⑨	<b>Platen</b>	This is the path over which the media passes. A suction fan that keeps the media from coming loose and a print heater that helps fix the ink are built in.
⑩	<b>Apron</b>	This has a built-in dryer to speed up drying of the ink.
⑪	<b>Wiper</b>	Cleans the print heads during automatic cleaning and in similar situations.
⑫	<b>Wiper tray</b>	This tray houses the TR cleaning liquid used to clean the wiper. It contains three tray pads.
⑬	<b>Waste valve</b>	Open this valve to drain the discharged fluid that has collected in the wiper tray.

### Serious Errors Indicated by the Print Light

If an error that may lead to serious damage to the printer occurs, the print light blinks in red.

This indicates one of the situations shown below.

When the print light blinks in red, the error also appears on the operation panel's display screen. Check the display screen, and then respond to the error according to the information in P. 199 "An Error Message Appears" in this manual.

Display screen	Error overview
AVOIDING DRY-UP TURN POWER OFF	The print heads were about to dry out. The print heads may be damaged if allowed to dry out.
MOTOR ERROR TURN POWER OFF	An excessive load was applied to the motor. If this error is not addressed, the print heads may be damaged.
TEMPERATURE IS TOO LOW **°C	The ambient temperature in the printer's installation location has fallen below the temperature in which operation is possible. If this error is not addressed, the printer may malfunction.
TEMPERATURE IS TOO HIGH **°C	The ambient temperature in the printer's installation location has risen above the temperature in which operation is possible. If this error is not addressed, the printer may malfunction.
CANCELED FOR PUMP PROTECTION	An excessive load was applied to the pump within the machine. If this error is not addressed, the pump may malfunction.
SERVICE CALL xxxx	An unrecoverable error or an error that requires a part replacement has occurred.

### **If a Cover Opens during Operation**

---

If the front cover, left cover, or right cover (hereinafter referred to as "cover") opens during an operation in which the print-head carriage moves such as printing or cutting, the machine makes an emergency stop.

When an emergency stop occurs, a message prompting you to close the cover will be displayed on the screen.

Follow the instruction shown on the screen and close the cover.

After you close the cover, the following message appears on the screen. Follow the instruction shown on the screen and press [ENTER]. The machine recovers from the error and is then able to continue operations."

```
PRESS THE ENTER  
KEY TO CONTINUE
```

If the message shown above does not appear even after you close the cover, a nonrecoverable error may have occurred. Refer to P. 199 "An Error Message Appears".

## Operation Panel

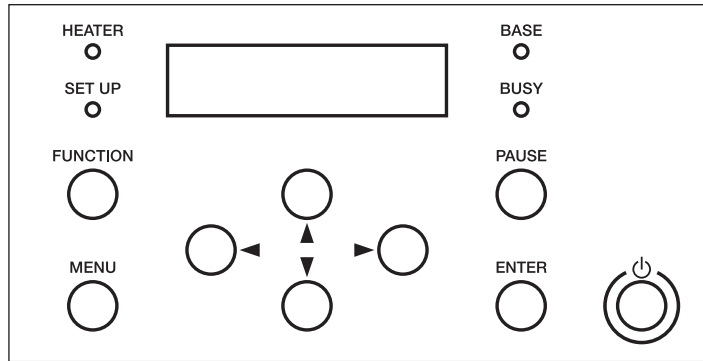

Part	Name	Description	Notation in this manual
	Display screen	This displays various setting menus and other information.	
	Sub power switch	This switches the printer on and off. (To switch the printer off, hold down the switch for one second or longer). The light flashes slowly when the machine is in sleep mode.	
<b>ENTER</b>	ENTER key	Use this for such tasks as enabling setting values.	[ENTER]
<b>MENU</b>	MENU key	Press this to enter the menus for various settings.	[MENU]
<b>FUNCTION</b>	FUNCTION key	Press this when entering the setting menu for cleaning of the print heads, printing tests, and so on.	[FUNCTION]
<b>PAUSE</b>	PAUSE key	This pauses the printing operation. It lights when operation is paused.	[PAUSE]
	Cursor keys	Use these to select settings for menu items, to move the media, and for other such operations.	[◀] [▼] [▲] [▶]
<b>BUSY</b>	BUSY light	This lights during printing and other such operations.	[BUSY]
<b>SETUP</b>	SETUP light	This lights when media has been loaded correctly.	[SETUP]
<b>BASE</b>	BASE POINT light	This lights when the base point (the output-start location) has been set.	[BASE]
<b>HEATER</b>	HEATER light	This flashes while the media heating system is warming up. It stays lit when the set temperature is reached.	[HEATER]

## Warning Labels

Warning labels are affixed to the machine to make areas of danger immediately clear. The meanings of these labels are as follows. Be sure to heed their warnings. Also, never remove the labels or allow them to become dirty.

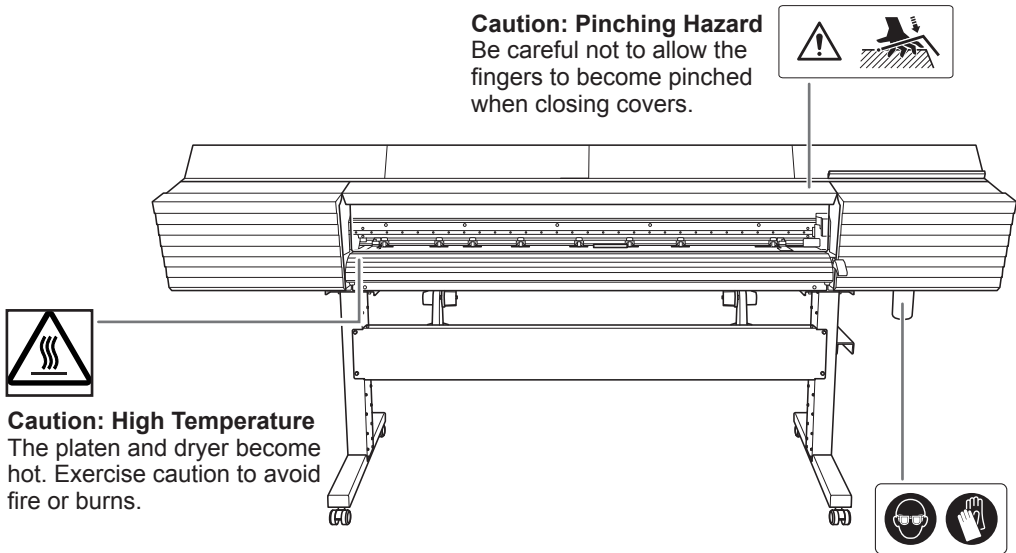

**Ink, cleaning liquid, and discharged fluid are toxic**  
If these fluids come into contact with the eyes or skin, it may be hazardous to the health. When performing maintenance work, for example when disposing of discharged fluid, wear protective eyewear and protective gloves (refer to the safety data sheet (SDS)).

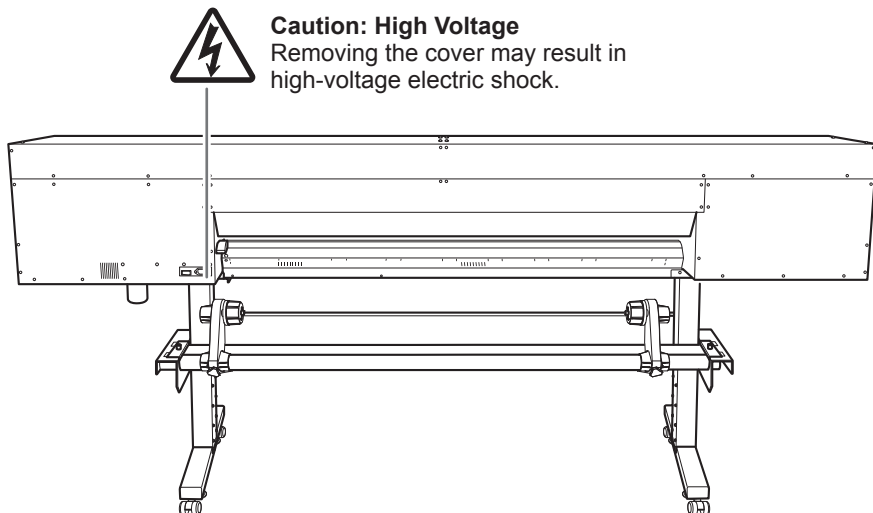
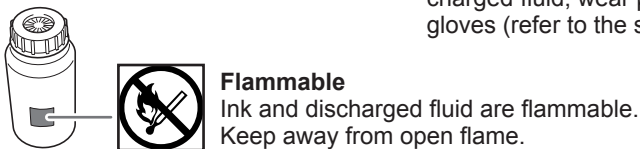

## Vignettes d'avertissement

Des vignettes d'avertissement sont apposées pour qu'il soit facile de repérer les zones dangereuses. La signification des vignettes est donnée ci-dessous. Respecter les avertissements. Ne jamais retirer les vignettes et ne pas les laisser s'encrasser.

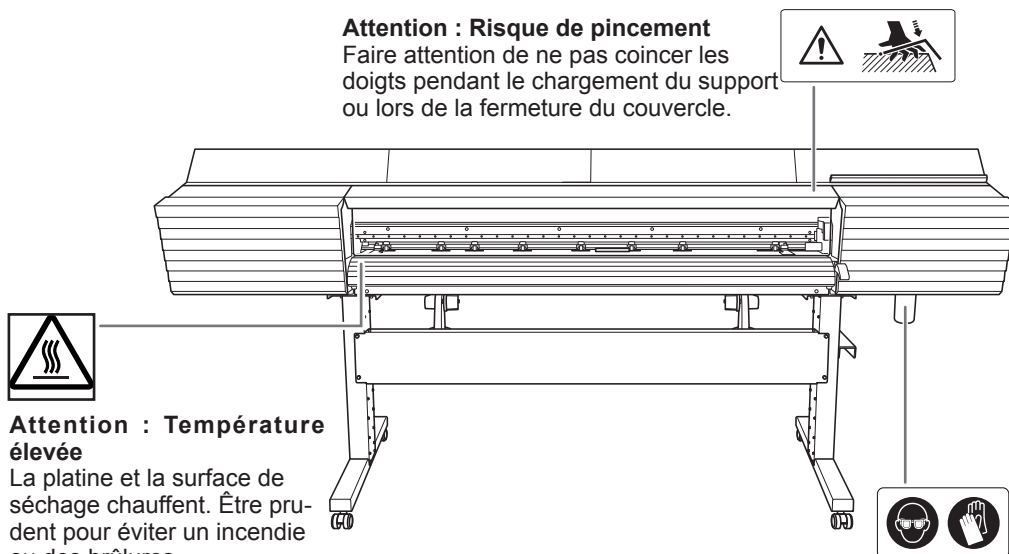

### L'encre, le liquide de nettoyage et le rejet liquide sont toxiques

Il peut s'avérer dangereux pour la santé si ces liquides viennent en contact avec les yeux ou la peau. Lors de travaux d'entretien, à l'élimination de rejets liquides par exemple, utilisez une protection oculaire et des gants protecteurs (se reporter à la fiche signalétique [FS]).

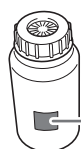

### Inflammable

L'encre et les liquides utilisés sont inflammables. Les garder loin de toute flamme nue.



### Attention : voltage élevé

Il peut être dangereux de retirer le couvercle puisqu'il y aurait des risques de chocs électriques ou d'électrocution à cause du voltage élevé.

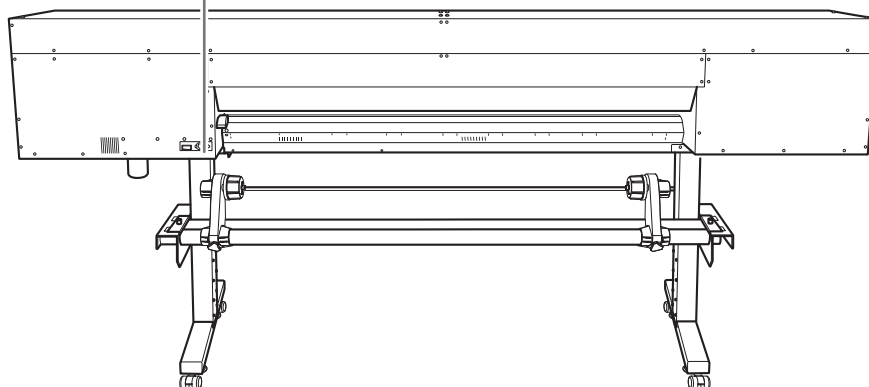

# Menu List

## Main Menu

Press [MENU].

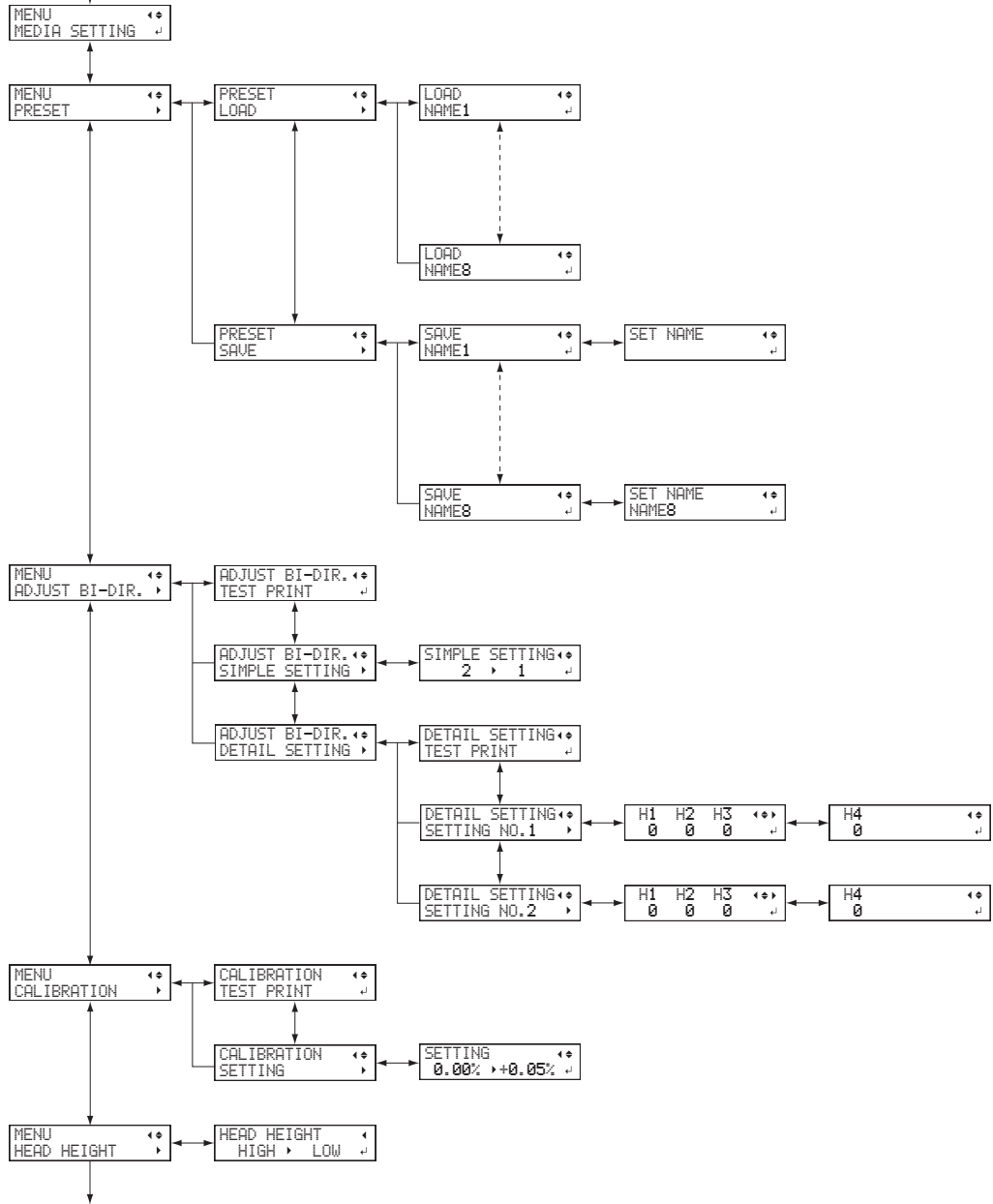

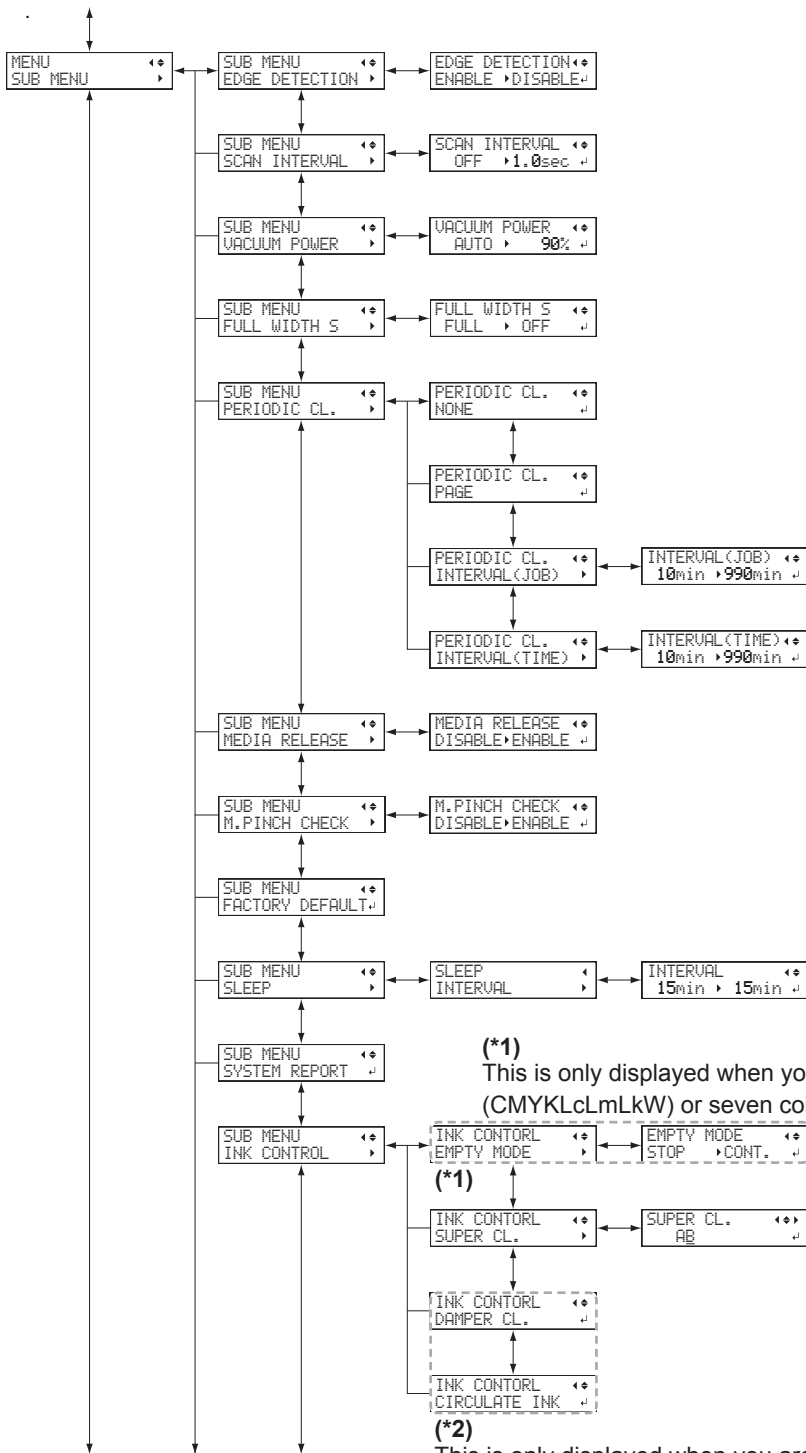

(\*1)  
This is only displayed when you are using eight colors (CMYKLcLmLkW) or seven colors (CMYKLcLmLk).

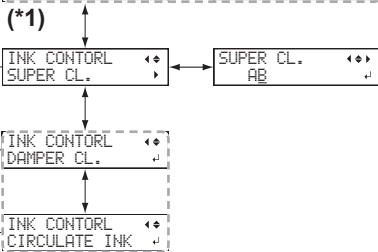

(\*2)  
This is only displayed when you are using eight colors (CMYKLcLmLkW).

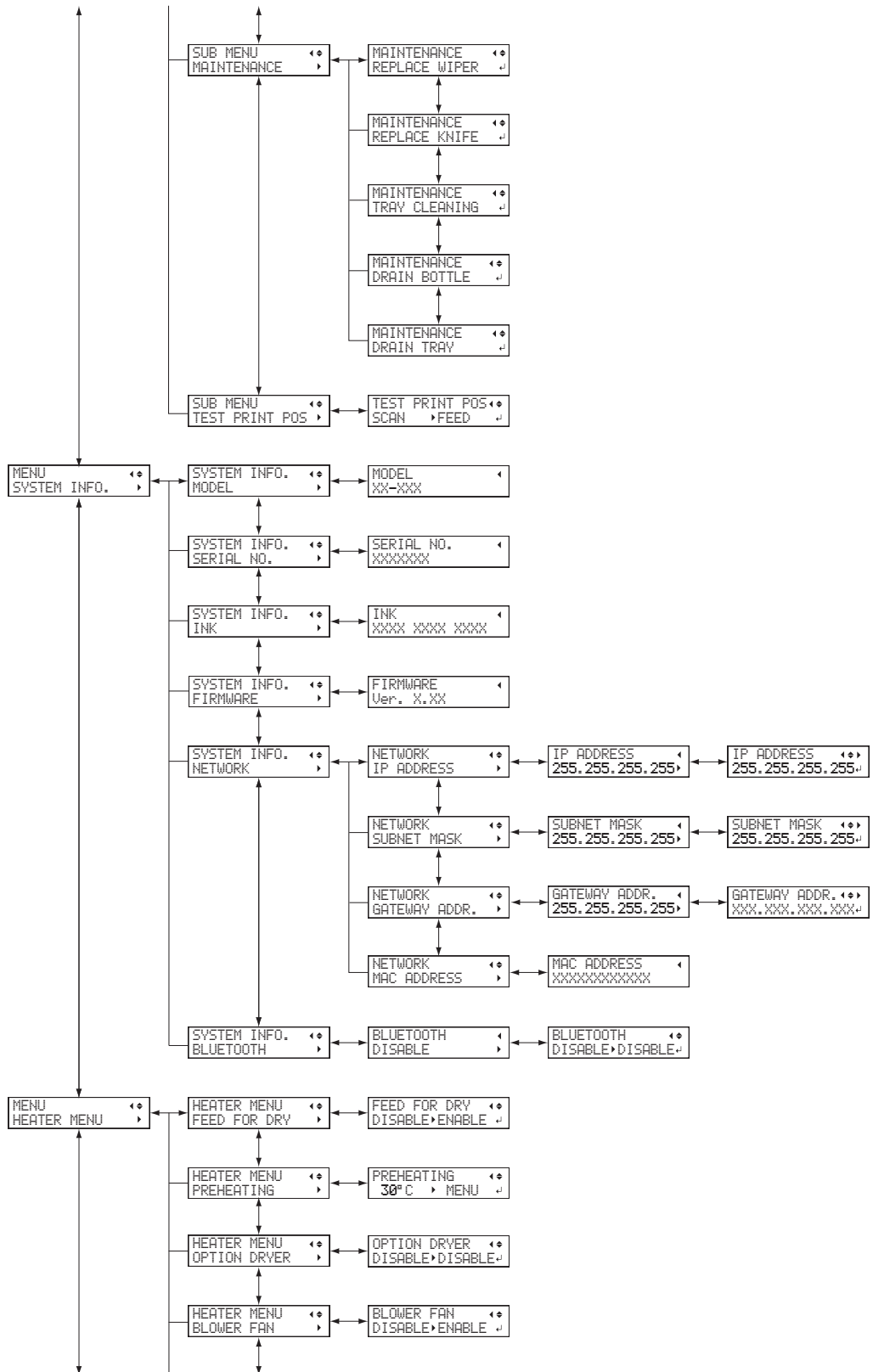

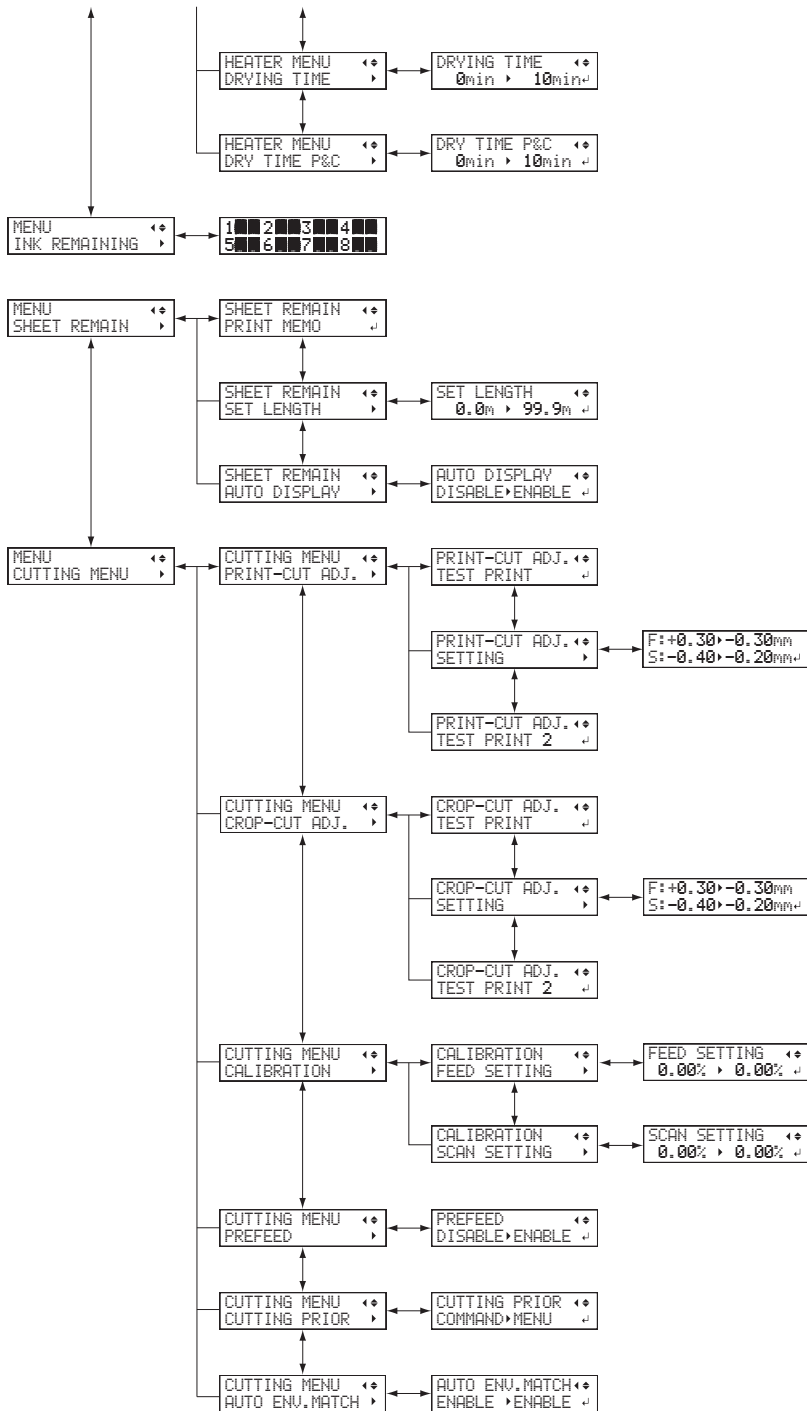

# Function Menu

1 Machine Highlights

Press [FUNCTION].

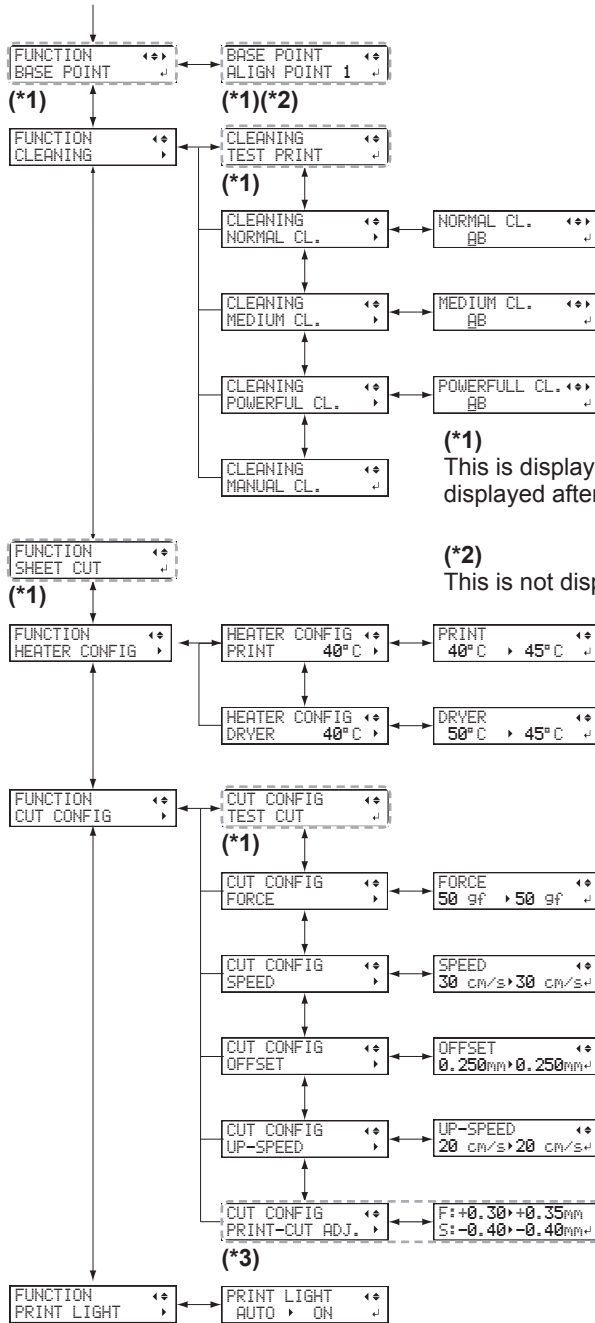

(\*1) This is displayed when the width of the media is displayed after the media has been loaded.

(\*2) This is not displayed when base point is not set.

(\*3) This is not displayed when [PAUSE] is not pressed.

## Language and Unit Menu

While holding down [MENU], switch on the sub power.

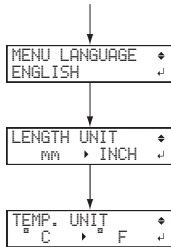

# Important Notes on Handling and Use

This machine is a precision device. To ensure the full performance of this machine, be sure to observe the following important points. Failure to observe them may not only result in loss of performance, but may also cause malfunction or breakdown.

## Printer Unit

### ***This machine is a precision device.***

---

---

- Never subject the machine to impacts or excessive force.
- Never needlessly put your hand or fingers inside the cover, the ink-pouch ports, or other internal areas of the machine.

### ***Install the machine in a suitable location.***

---

---

- Install the machine in a location having the specified temperature and relative humidity.
- Install the machine in a quiet, stable location offering good operating conditions.

### ***The print heads are delicate.***

---

---

- Never needlessly touch or allow media to scrape them.
- The print heads may be damaged if allowed to dry out. The machine prevents desiccation automatically, but improper operation may render this feature inoperative. Operate the machine properly, as specified in this manual.
- Never leave the machine with an ink pouch removed. The remaining ink in the printer may harden and clog the print heads.
- The print heads are components that wear out. Periodic replacement is required, with the frequency of replacement depending on use.

### ***This machine becomes hot.***

---

---

- Never cover the ventilation holes with cloth, tape, or anything else.

## Ink Pouches

***Ink pouches come in various types.***

---

- Use a type that is compatible with the printer.

***Never subject the machine to impacts or attempt to disassemble it.***

---

- Never drop the machine or shake it forcefully. The impact may rupture the internal pouches and cause the ink to leak.
- Never attempt to disassemble the machine.
- Never attempt to refill the ink.
- If ink gets on your hands or clothing, wash it off as soon as possible. Removal may become difficult if you leave such adhered ink untreated.

### ***Storage***

---

- Store the machine unopened in a well-ventilated location at a temperature of -5 to 40°C (-23 to 104°F). However, do not store the ink pouches for a prolonged period of time in low or high temperature environments.



# Chapter 2 Basic Operation

Power Supply Operations .....	24
Turning the Power On .....	24
Turning the Power Off.....	25
Precautions When Operating the Power Supply .....	26
Sleep Mode (Power-saving Feature).....	26
About the Media Used .....	27
Types of Media .....	27
Conditions for Usable Media .....	27
Basic Printing Method.....	28
Printing Flow.....	28
Step 1 : Loading Roll Media (Setup of Media).....	29
Step 2 : Initial Adjustment (Correcting for Misalignment in Bidirectional Printing).....	37
Step 3 : Batch Settings .....	39
Step 4 : Setting the Base Point.....	52
Step 5 : Printing Tests and Normal cleaning.....	53
Step 6 : Starting Output .....	56
Basic Settings for Cutting.....	59
Hints and Tips for Cutting Settings .....	59
Important Note on Cutting .....	59
Preventing Pulling of the Media with Undue Force.....	60
Setting the Cutting Test and the Blade Force .....	61
Printing and Cutting with Crop Marks .....	63
What Is Printing and Cutting with Crop Marks? .....	63
How to Print and Cut with Crop Marks .....	64
Printing and Cutting with Crop Marks: Basic Troubleshooting.....	66
Ink Pouch/TR Cleaning Liquid Pouch Replacement.....	68
Out-of-ink Warnings.....	68
Out-of-TR-cleaning-liquid Warnings .....	69
Ink Pouch Replacement .....	70
TR Cleaning Liquid Pouch Replacement.....	72
Other Basic Operations.....	74
Loading Sheet Media (Setup of Media).....	74
Pausing and Canceling Output.....	79
Cutting Off the Media.....	79

# Power Supply Operations

## Turning the Power On

### ⚠️ WARNING

When output is not being performed, remove any loaded media or switch off the sub power.

The continued application of heat at a single location may cause the release of toxic gases from the media or pose a fire hazard.

### Procedure

- 1 Close the front cover.

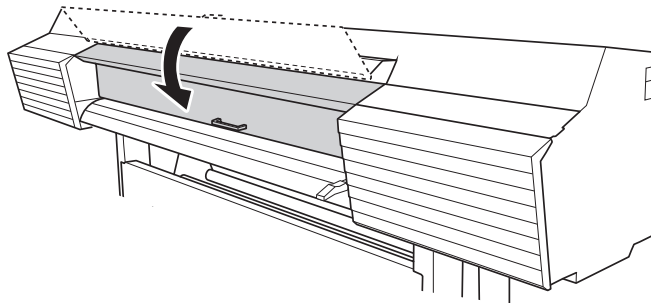

- 2 Turn on the main power switch.

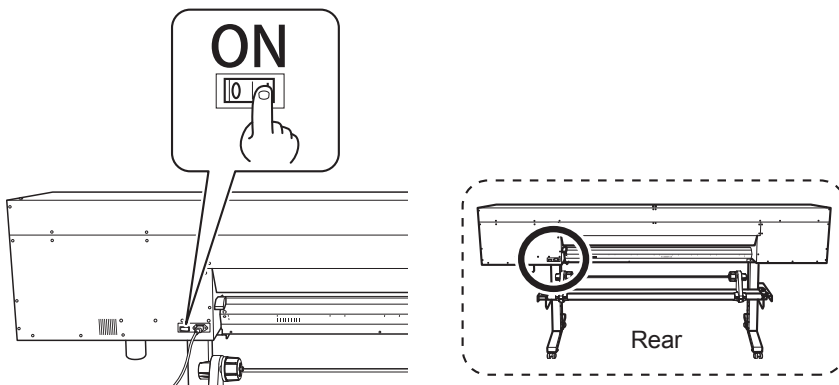

- 3 Press the sub power button.

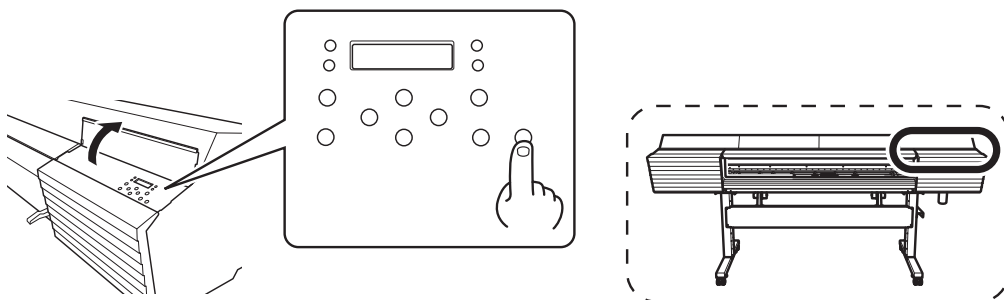

## Turning the Power Off

### **⚠ WARNING**

When output is not being performed, remove any loaded media or switch off the sub power.

The continued application of heat at a single location may cause the release of toxic gases from the media or pose a fire hazard.

### Procedure

#### **1 Switch off the sub power whenever printing is finished.**

Hold down the sub power switch for one second or longer.

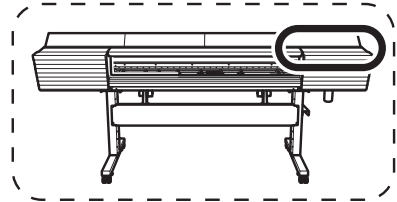
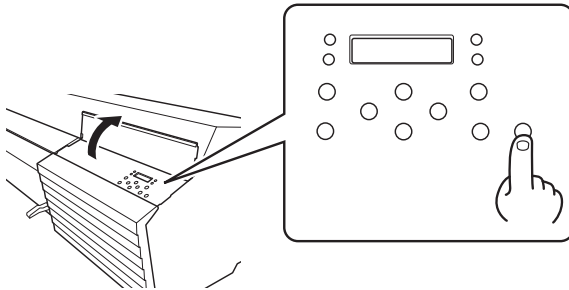

#### **2 Raise the loading lever and remove the media.**

When not using the machine, raise the loading lever even if the sub power is on.

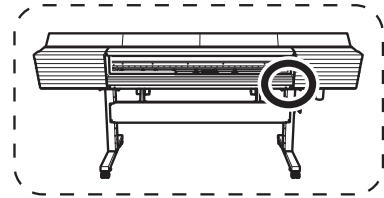
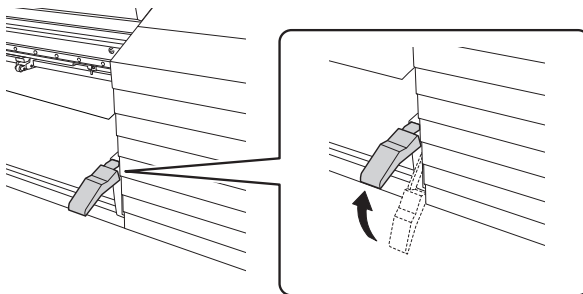

## Precautions When Operating the Power Supply

### ***Always keep the main power switched on.***

Never switch off the main power. Leaving the main power enables the automatic maintenance to be carried out periodically. If the automatic maintenance is not carried out, it may result in the breakdown of this machine, such as the breakdown of the print heads.

### ***Never switch off the main power or unplug the power cord suddenly while operation is in progress.***

Switching off the main power or unplugging the power cord suddenly while operation is in progress may damage the print heads. Be sure to first switch off the sub power. If the main power is accidentally switched off, immediately turn the main power and sub power back on.

## Sleep Mode (Power-saving Feature)

This machine is provided with a power-saving feature that switches to a low-power "sleep mode" when a fixed interval passes with no operation. The factory default for the time after which the machine switches to sleep mode is 30 minutes. When the machine is in the sleep mode, the sub power switch flashes slowly. Using the operation panel or performing operations such as sending print data from the computer restores the machine to its normal mode.

This sleep mode setting can be changed. However, we recommend setting the activation time for sleep mode to 30 minutes or less to reduce power consumption and prevent problems such as overheating.

☞ P. 171 "Setting the Activation Interval for Sleep Mode (Power-saving Feature)"

# About the Media Used

## Types of Media

In this manual, the paper used for output is called "media." There are the following two main media types used in this machine.

- **Roll media: Media wound onto a paper tube**
- **Sheet media: Media not wound onto a paper tube such as standard-size media**

Various paper qualities of roll media and sheet media are selectable according to the purpose. For detailed information about each media, contact your media supplier.

## Conditions for Usable Media

This machine cannot print on every kind of media. When selecting media, be sure to carry out testing in advance to make sure that satisfactory printing results are obtained.

### Size

	64-inch model	54-inch model
<b>Width (*a)</b>	210 to 1,625 mm (8.3 to 64 in.)	210 to 1,371 mm (8.3 to 54 in.)
<b>Cuttable media thickness (*a)</b>	0.08 to 0.22 mm (3.2 to 8.6 mil; depends on the material of the media)	
<b>Maximum media thickness (including backing paper) (*a)</b>	When performing printing only: 1.0 mm (39 mil) When performing cutting: 0.4 mm (15 mil)	
<b>Maximum roll outer diameter</b>	210 mm (8.2 in.)	
<b>Paper tube (core) inner diameter</b>	76.2 mm (3 in.) or 50.8 mm (2 in.) (*b)	

\*a Applies to both roll and sheet media.

\*b To use 2-inch media, the optional media flanges are required. For information about optional items, contact your authorized Roland DG Corporation dealer.

### Maximum Roll Weight

64-inch model: 40 kg (88 lb.)

54-inch model: 30 kg (66 lb.)

Note: If using the take-up unit, this specification depends on the conditions of media that can be used with the take-up unit.

### Other Conditions

Media such as the following cannot be used.

- Media whose end is attached to the paper tube (core)
- Media that is severely warped or that has a strong tendency to reroll
- Media that cannot withstand the heat of the media heating system
- Media whose paper tube (core) is bent or crushed
- Media that bends under its own weight when loaded
- Media on a sagging roll
- Media that is rolled unevenly

# Basic Printing Method

## Printing Flow

### Step 1. : Loading Roll Media (Setup of Media) (P. 29)

First, load the media on the printer. Load the media correctly according to the explanations.



### Step 2. : Initial Adjustment (Correcting for Misalignment in Bidirectional Printing) (P. 37)

Perform the printing correction. Be sure to perform this step the first time you use the machine. Also perform this step when you use a different type of media.



### Step 3. : Batch Settings (P. 39)

You can set the minimum of items necessary for output as a batch.



### Step 4. : Setting the Base Point (P. 52)

Set the base point in order to determine the output area.



### Step 5. : Printing Tests and Normal cleaning (P. 53)

Before you carry out actual printing, ensure no dot drop-out occurs. If dot drop-out occurs, perform cleaning.



### Step 6. : Starting Output (P. 56)

Send data from the computer and output it from the printer.

The above procedure is the basic flow of printing operations. The first time you print data, follow this procedure. Once you are used to the machine, configure advanced settings to obtain printing that matches your purpose. If the machine is used for a long time, a variety of maintenance operations may also become necessary.

## Step 1 : Loading Roll Media (Setup of Media)

Load the roll media on the printer. When you have finished loading the media, [SETUP] lights. This work is referred to as "Setup of Media."



**Load roll media correctly.**  
Otherwise the media may fall and cause injury.



**The roll media is approximately 40 kg (88 lb.). To avoid injury, handle the roll media with care.**



**Never load roll media that weighs more than 40 kg (88 lb.) or that weighs more than 30 kg (66 lb.) in the case of the 54-inch model.**  
The machine may tip over because it is incapable of withstanding the weight. Alternatively, the media may fall out of the machine.

### 1. Install the media on the media holders.

Note: The media holders of this machine are designed to be used exclusively with media that has a paper tube (core) with an inner diameter of 3 inches. To use 2-inch media, the optional media flanges are required. For information about optional items, contact your authorized Roland DG Corporation dealer.

1 Open the front cover.

2 Move the media clamps to the left and right ends respectively.

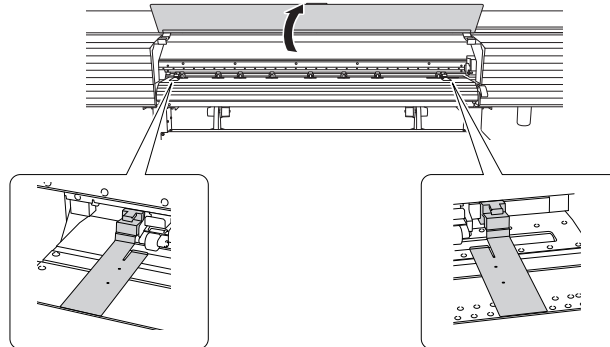

3 Loosen the retaining screws of the media holders, and then draw them to the left and right ends respectively.

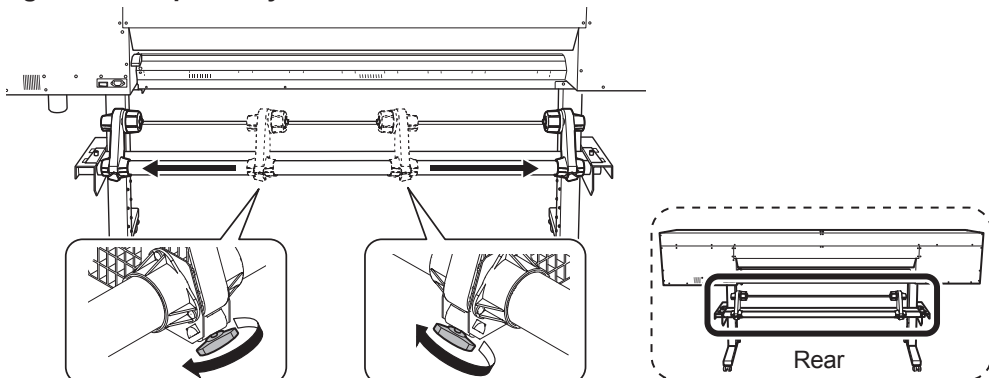

- 4** Fit the paper tube (core) of the media on the end cap of the left media holder, and then move the right media holder to fit its media cap onto the paper tube (core) of the media. Fit the paper tube onto the media holders securely to prevent the media from moving easily.

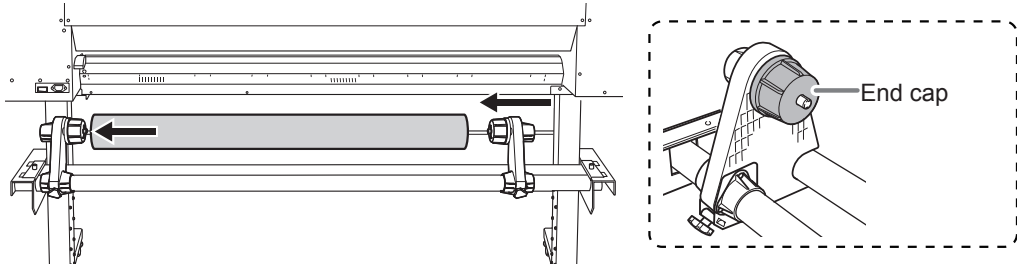

***IMPORTANT*** Position the left media holder correctly.

If the position of the left media holder is incorrect, media may not be fed properly, which will have an adverse effect on the printing results. Use the following procedure to determine the appropriate position.

***IMPORTANT*** Do not secure the media holders in place just yet.

In the following procedure, you will adjust the positions of the media holders before securing them in place. Do not secure them in place just yet.

## 2. Determine the positions of the media holders, and then secure them in place.

### 1 Determine the left and right positions of the media with the grit patterns used as the reference.

Note the following points when determining the positions.

- Hold the media holders from the outside and move the media.
- Ensure that both edges of the media are positioned so that they are within the range of the grit patterns.
- Ensure that the left edge of the media is positioned so that it is within the range of the grit pattern of the left edge.
- Ensure that the edge of the media is not within the range of 20 mm (0.79 in.) to the right of the grit pattern of the left edge or 20 mm (0.79 in.) to the left of other grit patterns.

Grit pattern (Place the left edge of the media within this range.)

Grit pattern (Place the right edge of the media within this range.)

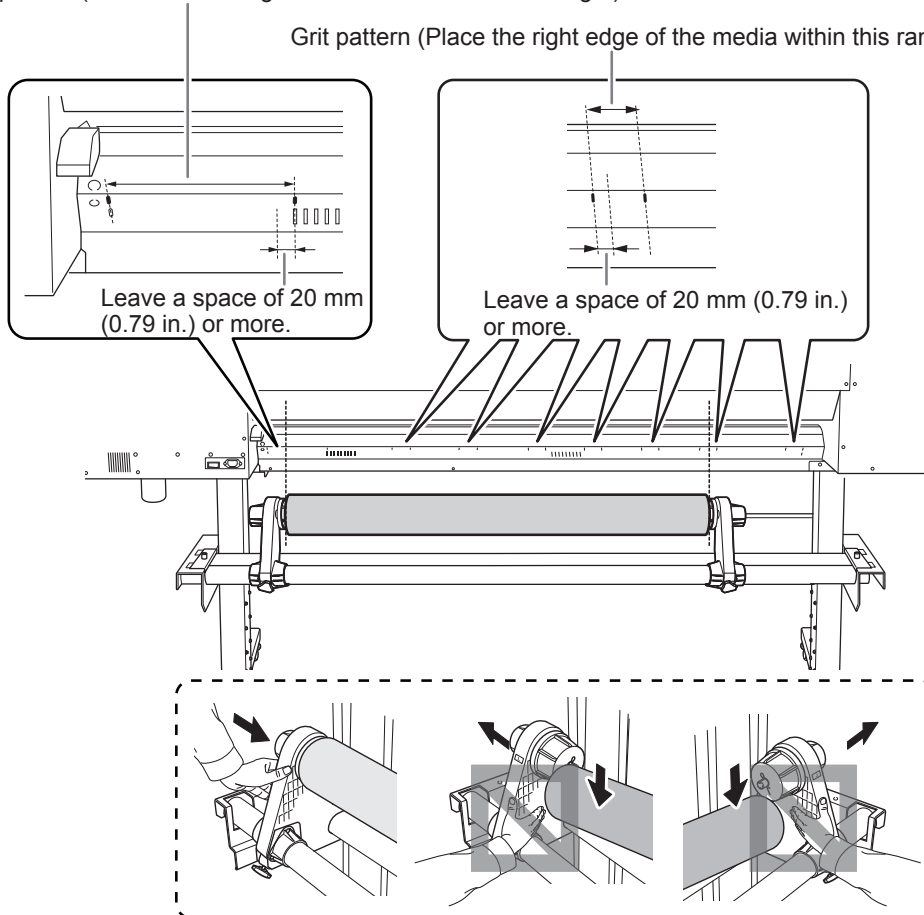

### ⚠ CAUTION

Do not hold places other than those instructed. Do not move the media by holding it directly.

Otherwise the media may fall off the media holder and cause injury.

***IMPORTANT*** *Firmly decide the left and right side positions of the media at this point.*

After this procedure is completed, if the left and right side positions do not fit the proper positions when securing the media with pinch rollers, you will have to go back to this step to redo this procedure. If you just hold the media to readjust its position forcibly, the media will be skewed during printing, which will have an adverse effect on the printing results.

**2** Secure the media holders by tightening the retaining screws.

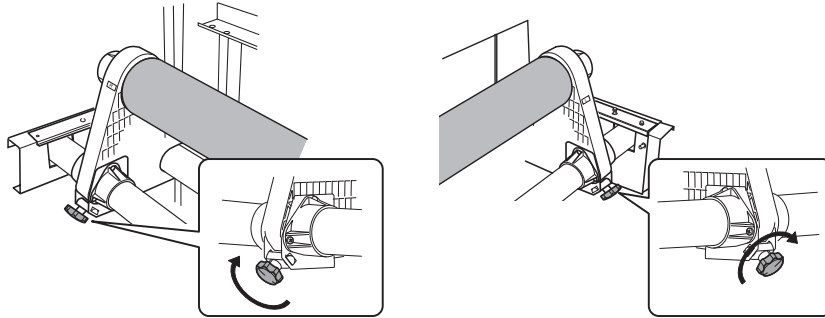

**3.** Pull out the media over the platen.

**1** Pass the leading edge of the media between the pinch rollers and the grit rollers.

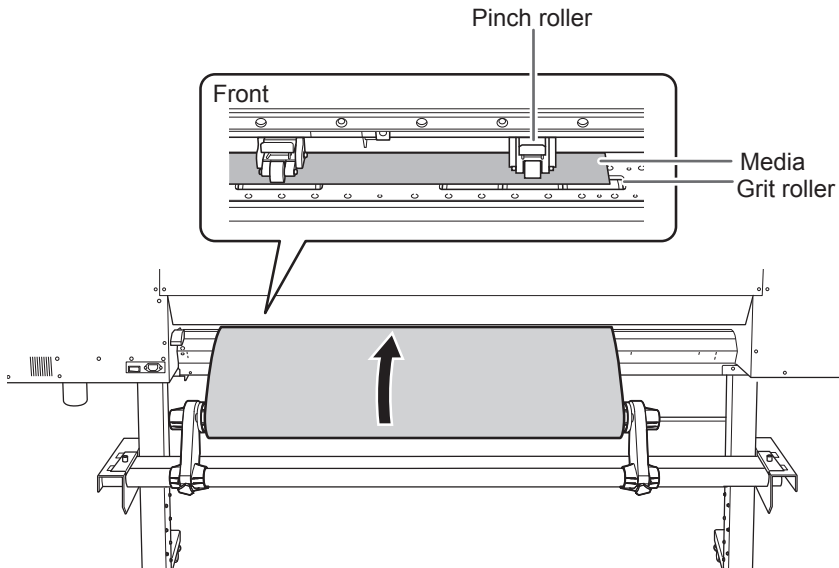

- 2 Make sure the front cover is open.

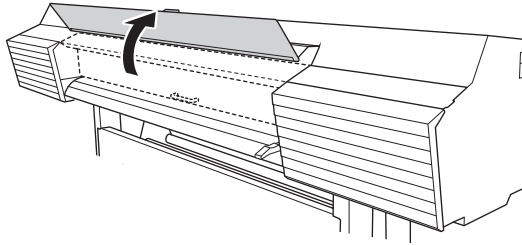

- 3 Lower the loading lever (rear).

The media is held in place.

At this time, the message "CLOSE FRONT COVER" is displayed on the screen, but continue operations without closing the front cover.

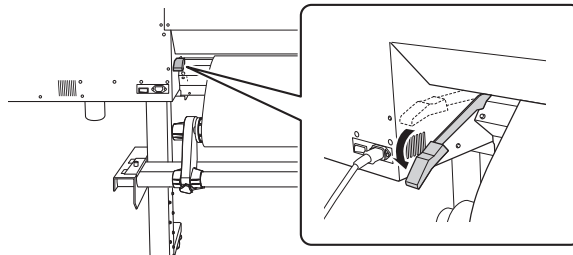

- 4 (Move to the front of the printer.) Gently hold down the media and raise the loading lever (front).

The media is released.

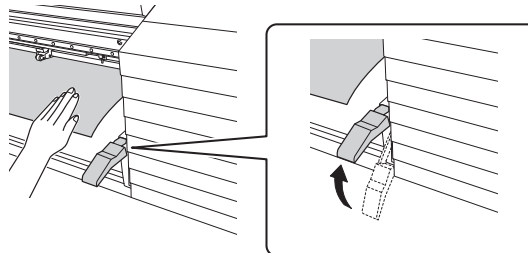

- 5 Pull out the media over the platen.

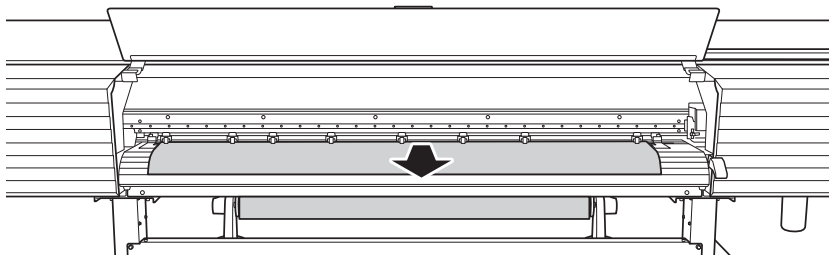

4. Secure the media in place.

1 Make sure both edges of the media are above the grit rollers.

Be sure to place the right edge of the media on the right-end grit roller.

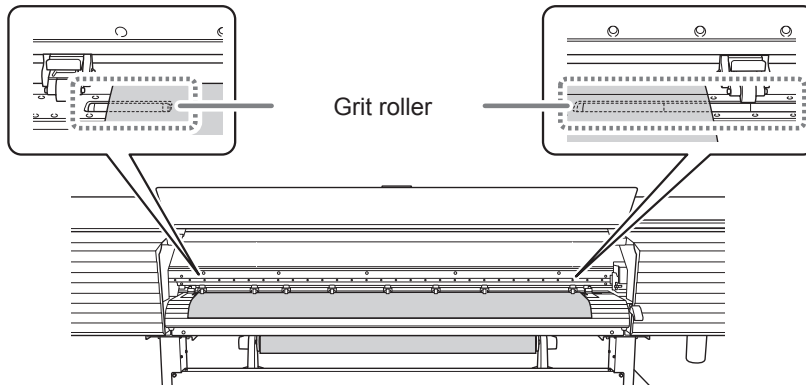

2 Place the left and right pinch rollers (affixed with blue stickers) on both edges of the media.

Position them approximately 10 mm (0.39 in.) from each edge of the media.

Left pinch roller (affixed with a blue sticker)

Right pinch roller (affixed with a blue sticker)

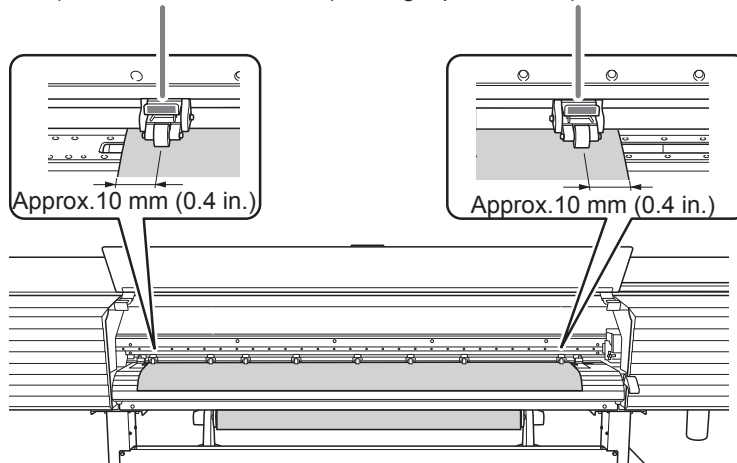

***If you want to readjust the media position before securing it in place, redo the procedure from step 2-1.***

If you just hold the media to readjust its position forcibly, the media will be skewed during printing, which will have an effect on the printing quality.

- 3** Place the middle pinch rollers over all the remaining grit rollers covered by the media. There are grit patterns wherever there are grit rollers. Be sure to remove the remaining middle pinch rollers.

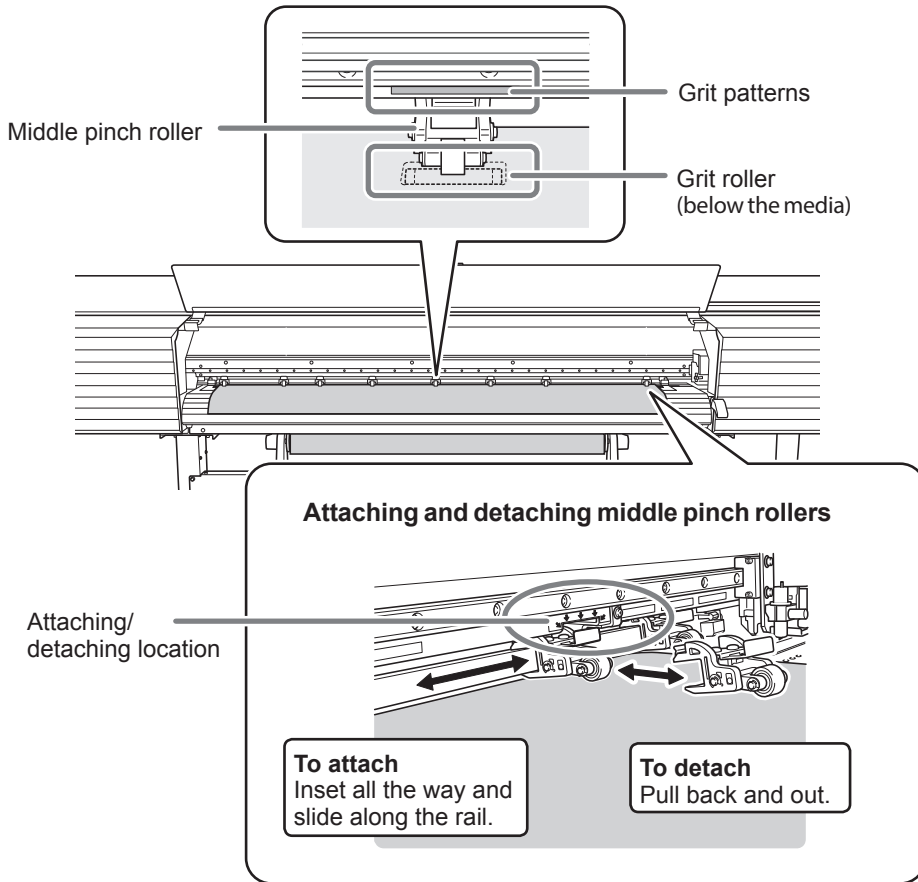

- 4** Hold the media at the center and pull it out, being sure to keep it straight and all areas of the media to be taut.

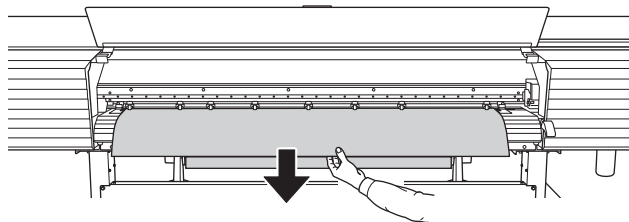

**Good**



**Not good**

**5 Lower the loading lever (front).**

The media is held in place.

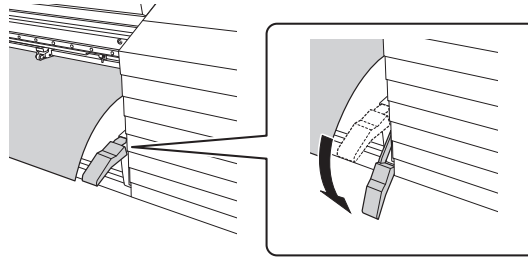

**6 Line up the edges of the media with the centers of the holes of the media clamps (left and right).**

When you are performing cutting only, do not use the media clamps.

☞ P. 59 "Important Note on Cutting"

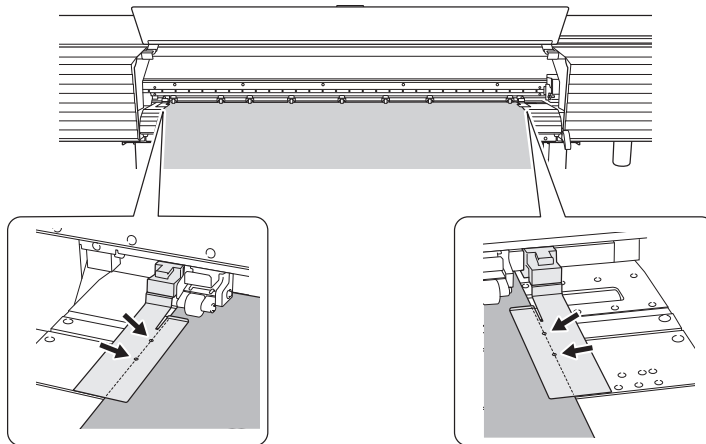

**7 Close the front cover.**

If the [PRESS THE ENTER KEY TO CONTINUE] message appears on the screen, press [ENTER].

When the front cover is closed, the print-head carriage moves and detects the width of media. This operation is called initialization. When initialization ends, [SETUP] on the operation panel lights, and the printable width is displayed on the screen. This completes the setup of the media.

***IMPORTANT Remove when not using roll media.***

Do not leave roll media loaded on the machine for a long period of time. Be sure to remove and store the media when not in use. Leaving the roll media loaded on the machine for a long period of time will cause the media to sag, which may deteriorate the printing quality and may also lead to motor errors.

## Step 2 : Initial Adjustment (Correcting for Misalignment in Bidirectional Printing)

This machine performs bidirectional printing (in which the heads perform printing during both their outbound pass and return pass). This method offers the advantage of being able to shorten output times, but subtle misalignment occurs during the outbound and return passes, which makes "bidirectional correction" necessary. This adjustment must be performed in the following cases.

- When using this machine for the first time
- When changing the media to use
- When printing is not improved by performing simple correction for bidirectional printing (P. 131 "Correcting for Misalignment in Bidirectional Printing")

### 1. Print the adjustment pattern for bidirectional printing.

1 Press [MENU].

2 Press [▼] several times to display the screen shown below.

```
MENU          ◀◆
ADJUST BI-DIR ▶
```

3 Press [▶], then [▲] to display the screen shown below.

```
ADJUST BI-DIR. ◀◆
DETAIL SETTING ▶
```

4 Press [▶] to display the screen shown below.

```
DETAIL SETTING ◀◆
TEST PRINT     ◀
```

5 Press [ENTER].

A test pattern is printed.

### 2. Set the correction values.

1 When printing is finished, press [▼] to display the screen shown below.

```
DETAIL SETTING ◀◆
SETTING NO.1  ▶
```

2 Press [▶] to display the screen shown below.

```
H1  H2  H3  ◀◆▶
 0   0   0   ◀
```

**3** View the printed test pattern, and then determine the correction values from "BI-DIR NO.1 H1" to "BI-DIR NO.1 H4."

The test pattern is made of groups of two lines. Select the value that gives the least misalignment between the two lines. In the case of the following figure, select "+5" for H1 and H3 and "+4" for H2 and H4. When you cannot choose between two sequential numbers, select a value that is between them (you can set correction values in units of "0.5").

2  
Basic  
Operation

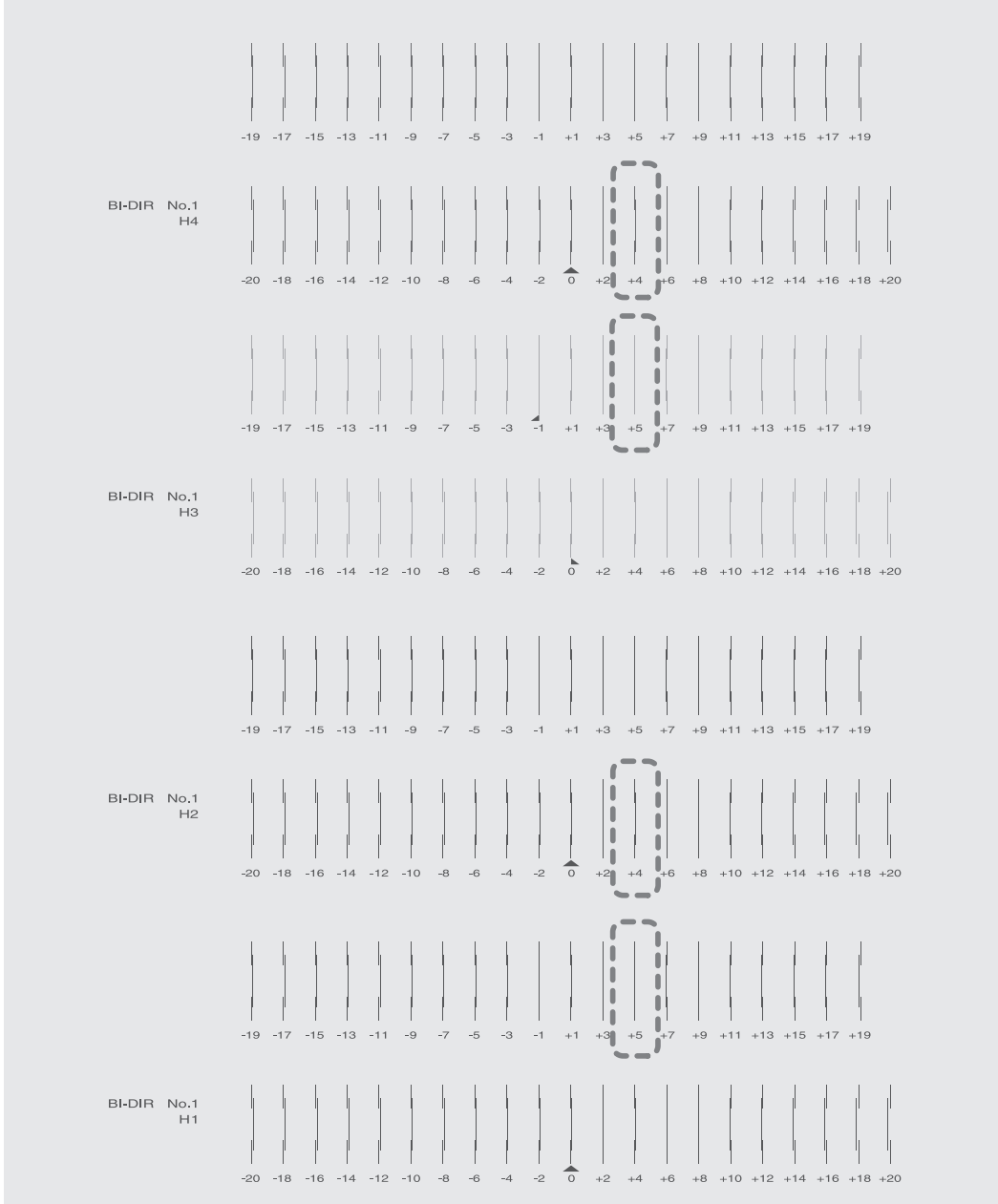

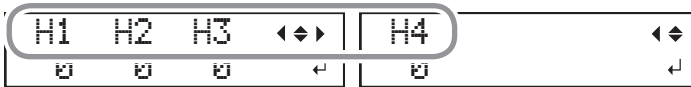
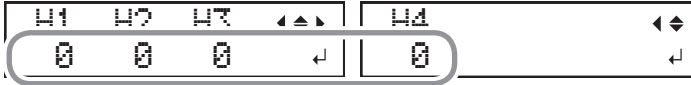
**4** Set the correction values from "H1" to "H4."**①** Press [◀] or [▶] to select a value from H1 to H4.**②** Press [▲] or [▼] to select the correction value.**③** When you have finished setting the correction values, press [ENTER].

The screen shown below appears again.

**5** Press [▼] to display the screen shown below.**6** Set the correction values from "BI-DIR NO.2 H1" to "BI-DIR NO.2 H4" in the same manner as step **4**.**7** Repeat step **1** to check whether the correction was successful.

For all the correction values, check that the misalignment is minimized for the two vertical lines indicated by "▲" (that is, the current correction value). If the misalignment is smaller for another set of vertical lines, set the correction value again.

**8** When you have successfully performed the correction, press [MENU] to go back to the original screen.

## Step 3 : Batch Settings

To ensure the optimal output according to the media size and type, you can configure various settings on this machine. However, it is hard work to configure these settings one at a time. You can use the "MEDIA SETTING" menu to configure the absolute minimum of necessary items as a batch. You can save the setting details as a preset.

Note that you can set all the items set here individually as well.

### 1. Start the "MEDIA SETTING" menu.

**1** Load the media.

Check that the media is not sagging. If any sagging exists, settings such as the correction values will not function effectively.

☞ P. 29 "Step 1 : Loading Roll Media (Setup of Media)", P. 74 "Loading Sheet Media (Setup of Media)"

2 Press [MENU].

3 Press [ENTER].



If you want to cancel the batch settings before they are completed, see the following page.  
 ↗ P. 52 "Canceling Batch Settings before They Are Completed"

## 2. Set the print heater and dryer temperatures. (Separate setting ↗ P. 124)

1 Press [▲] or [▼] to set the "PRINT HEATER" temperature.

Recommended temperature: 40°C (104°F)



Current set      Temperature  
temperature    to be set

2 Press [ENTER] to confirm your entry.

3 Press [▲] or [▼] to set the "DRYER" temperature.

Recommended temperature: 45°C (113°F)



4 Press [ENTER] to confirm your entry.

## 3. Adjust the print head height. (Separate setting ↗ P. 135)

1 Press [←] to select "CHANGE."

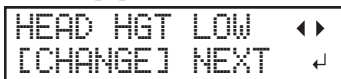

2 Press [ENTER] to confirm your entry.

You can select "NEXT" and press [ENTER] to proceed to the next menu.

3 When the following screen is displayed, open the front cover.



**4 Move the height-adjustment lever to adjust the head height.**

When you change the position of the height-adjustment lever, the display screen will change.

When the lever is moved to the "High" direction, the buzzer sounds twice. When it is moved to the "Low" direction, the buzzer sounds once.

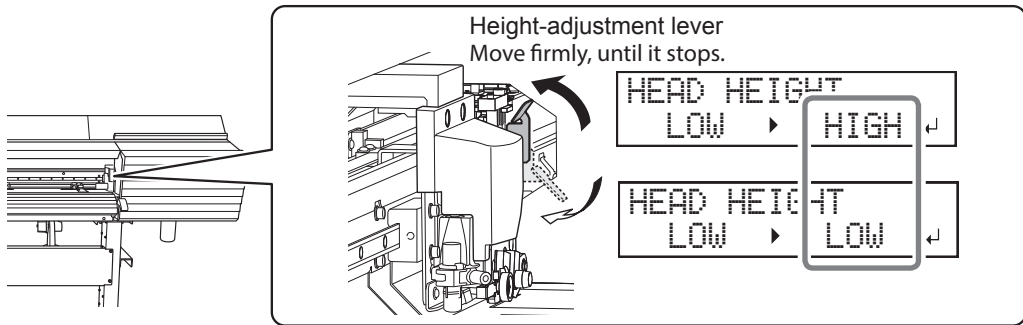
**MEMO**

Normally move the height-adjustment lever to "Low." For media that is wrinkled or comes loose from the platen, move the height-adjustment lever to "High."

**5 Close the front cover.**

If the [PRESS THE ENTER KEY TO CONTINUE] message appears on the screen, press [ENTER].

**4. Perform position correction of the feed direction (reduce horizontal stripes). (Separate setting [P. 133](#))****MEMO**

Feed direction means the feed direction of the media. Perform the correction adjusting to the media in advance because horizontal stripes are more likely to occur during printing when the movement distance of the media changes subtly depending on the media's thickness.

**1 Press [←] to select "YES."**

```
CALIBRATION  ◀▶
[SET]  NEXT  ↵
```

**2 Press [ENTER] to confirm your entry.**

The test pattern of feed correction is printed.

You can select "NEXT" and press [ENTER] to proceed to the next menu.

**3 Press [ENTER].**

```
INPUT
  ADJ. VALUES ↵
```

**4 View the printed test pattern, and then determine the correction value.**

Select the value to make the gap and overlap between the upper/lower squares smallest. In the case of the following figure, select "-0.40." When you cannot choose between two sequential numbers, specify a value that is between them.

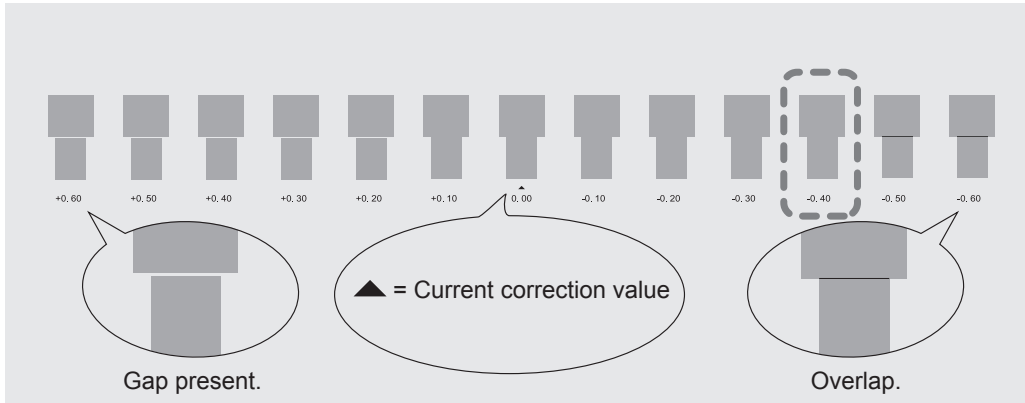

**5 Press [▲] or [▼] to select the correction value.**



**6 Press [ENTER] to confirm your entry.**

**7 Press [←] to select "YES."**

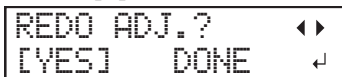

**8 Press [ENTER] to confirm your entry.**

The test pattern is printed again. Check that the gap and overlap are the smallest for the figure indicated by "▲" (that is, the current correction value). If the gap and overlap are smaller for another figure, return to step 5 to perform the setting again.

If you do not need to change the correction value, press [ENTER] again.

**9 Press [▶] to select "DONE."**



**10 Press [ENTER] to confirm your entry.**

## 5. Perform correction for misalignment in bidirectional printing. (Separate setting P. 131)

- 1 Press [←] to select "YES."

```
ADJUST BI-DIR. ◀▶
[SET]  NEXT  ↵
```

- 2 Press [ENTER] to confirm your entry.

The test pattern of bidirectional correction is printed.

You can select "NEXT" and press [ENTER] to proceed to the next menu.

- 3 Press [ENTER].

```
INPUT
  ADJ. VALUES ↵
```

- 4 View the printed test pattern, and then determine the correction value.

Select the value that gives the least misalignment between the two lines. In the case of the following figure, select "+5." When you cannot choose between two sequential numbers, select a value that is between them (you can set correction values in units of "0.5").

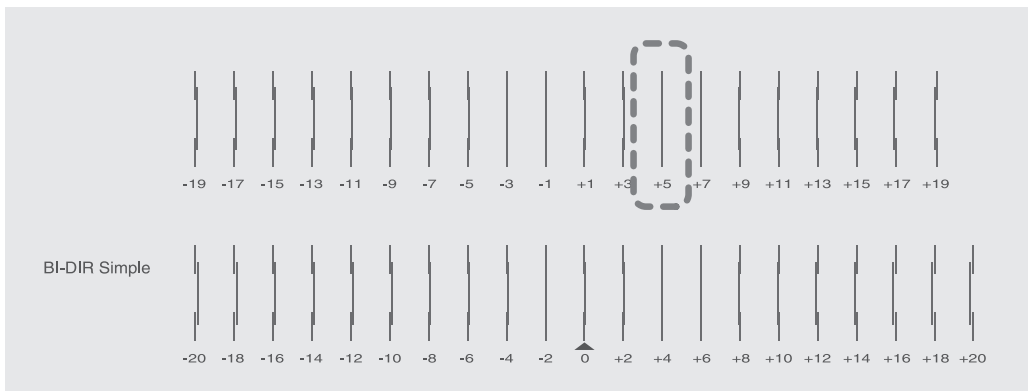

- 5 Press [▲] or [▼] to select the correction value.

```
ADJUST BI-DIR. ◆
  0 ▶ 5  ↵
```

- 6 Press [ENTER] to confirm your entry.

- 7 Press [←] to select "YES."

```
REDO ADJ.? ◀▶
[YES]  DONE  ↵
```

**8 Press [ENTER] to confirm your entry.**

The test pattern is printed again. Check that the misalignment is minimized for the two vertical lines indicated by "▲" (that is, the current correction value). If the misalignment is smaller for another set of vertical lines, return to step **5** to perform the setting again.

If you do not need to change the correction value, press [ENTER] again.

**9 Press [▶] to select "DONE."**

```

REDO ADJ.?  ◀▶
YES  [DONE]  ↵
  
```

**10 Press [ENTER] to confirm your entry.****6. Decide to perform the setting for cutting or not.****1 Press [◀] or [▶] to select "NEXT" or "SET."**

Select "NEXT" when you will only perform printing. Select "SET" when you will perform cutting (including printing and cutting as well as crop mark printing and cutting).

```

CUT CONFIG  ◀▶
[SET]  NEXT  ↵
  
```

**2 Press [ENTER] to confirm your entry.**

If you select "YES," proceed to the next procedure.

If you select "NEXT," proceed to step **10**.

**7. Set the blade force. (Separate setting ☞ P.142)****MEMO**

For high-quality cutting, perform a cutting test to check the cutting quality for the media and adjust the blade force.

**1 Press [◀] to select "YES."**

```

CUT FORCE  ◀▶
[SET]  NEXT  ↵
  
```

**2 Press [ENTER] to confirm your entry.**

The test pattern is cut.

You can select "NEXT" and press [ENTER] to proceed to the next menu.

- 3 Peel off the two cut shapes (a circle and a square).

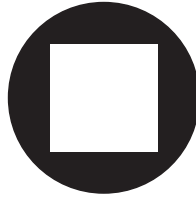

- 4 [Two shapes are peeled off together/backing paper is also cut]  
Press [←] to select "YES."

```
CONTINUE ADJ.? <>
[YES] DONE      ↵
```

[Two shapes are peeled off separately]  
Press [→] to select "DONE."

```
CONTINUE ADJ.? <>
YES [DONE]     ↵
```

- 5 Press [ENTER] to confirm your entry.  
If you select "YES," proceed to the next procedure.  
If you select "DONE," proceed to step 8.

- 6 Press [▲] or [▼] to adjust the blade force.  
If the two shapes are peeled off together ⇒ increase the blade force.  
If the backing paper is also cut ⇒ reduce the blade force.

```
CUT FORCE      ◆
50gf ▶ 60gf  ↵
```

- 7 Press [ENTER] to confirm your entry.  
The test pattern is cut again. Check the result.

- 8 [Two shapes are peeled off together/backing paper is also cut]  
Press [←] to select "YES."

```
REDO ADJ.?    <>
[YES]  DONE   ↵
```

[Two shapes are peeled off separately]  
Press [→] to select "DONE."

```
REDO ADJ.?    <>
YES  [DONE]   ↵
```

- 9 Press [ENTER] to confirm your entry.  
If you select "YES," the test pattern is cut again. Go back to step 6 and perform the setting again.  
If you select "DONE," proceed to step 9.

**8. Correct the misalignment of the printing and cutting positions. (Separate setting**  
 P. 146)

**MEMO**

Subtle misalignment between the printing and cutting positions may occur due to the thickness of the media or the head height. We recommend that you make corrections to match the media you are using.

**1 Press [←] to select "YES."**



**2 Press [ENTER] to confirm your entry.**

The test pattern (P&C1) is printed and cut. The test pattern is printed at three locations on the media: at the two edges and in the center.

You can select "NEXT" and press [ENTER] to proceed to the next menu.

**3 Check the test pattern (P&C1).**

Check for misalignment in the cutting position and printing position.

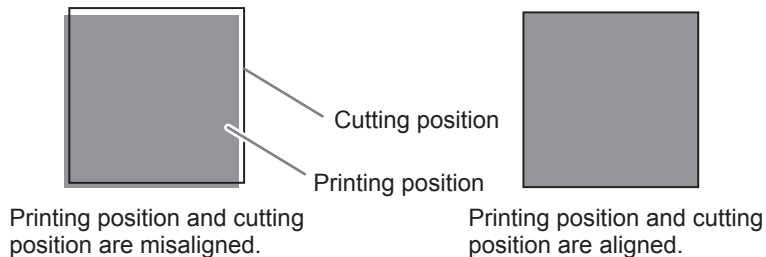

**4 [Cutting position and printing position are not aligned]**

Press [←] to select "YES."



[Cutting position and printing position are aligned]

Press [→] to select "DONE."



**5 Press [ENTER] to confirm your entry.**

If you select "YES," the test pattern (P&C2) for setting the correction values is printed and cut. Proceed to the next step.

If you select "DONE," proceed to step 9.

**6 Press [ENTER].**

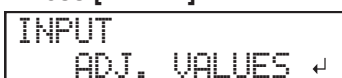

### 7 Check the correction values from the test pattern (P&C2) condition.

The point where the cutting line intersects the correction-value scale is the correction value. Check the scan direction (the direction of print head movement) and the feed direction (the media feed direction).

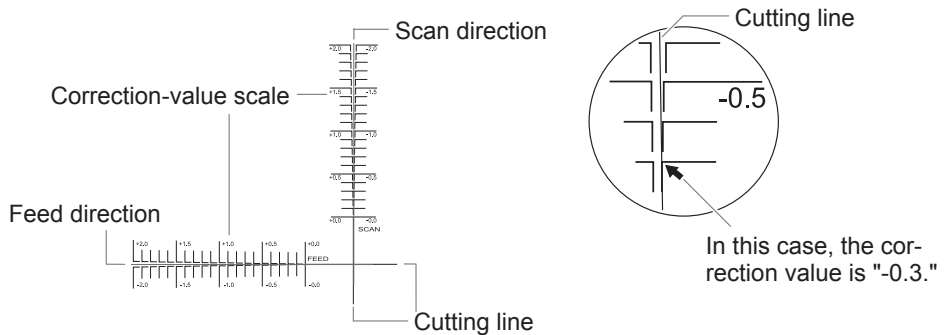

### 8 Set the correction values for the feed direction "F" and the scan direction "S."

① Press [▲] or [▼] to set the correction value for the feed direction (F).

```
F: +0.30 ▶ -0.30mm
S: -0.40 ▶ -0.20mm ↵
```

② Press [←] or [→] to set the correction value for the scan direction (S).

```
F: +0.30 ▶ -0.30mm
S: -0.40 ▶ -0.20mm ↵
```

③ When you have finished setting the correction values, press [ENTER].

The test pattern (P&C1) is printed and cut again. Check the condition of the test pattern to check whether the printing position and the cutting position are aligned.

### 9 [Cutting position and printing position are not aligned]

Press [←] to select "YES."

```
REDO ADJ.?   ◀▶
[YES]  DONE  ↵
```

[Cutting position and printing position are aligned]

Press [→] to select "DONE."

```
REDO ADJ.?   ◀▶
YES  [DONE]  ↵
```

### 10 Press [ENTER] to confirm your entry.

If you select "YES," the test pattern (P&C1) is printed and cut again. Go back to step 7 and perform the setting again.

If you select "DONE," proceed to the next procedure.

**9. Correct the misalignment of the printing and cutting positions when using crop marks. (Separate setting ☞ P.154)**

**MEMO**

When you remove the printed media, and then reload it and perform cutting, use the crop marks. For this case, correction is to be performed because the positioning of printing and cutting may be misaligned even when you are using crop marks depending on the composition of the media.

**1 Press [←] or [→] to select "NEXT" or "SET."**

Select "NEXT" when you will not print crop marks. Select "SET" when you will print crop marks.



**2 Press [ENTER] to confirm your entry.**

If you select "SET," the test pattern (C&C1) is printed and cut. Proceed to the next step. If you select "NEXT," proceed to step **10**.

**3 Check the test pattern (C&C1) condition.**

Check for misalignment in the cutting position and printing position.

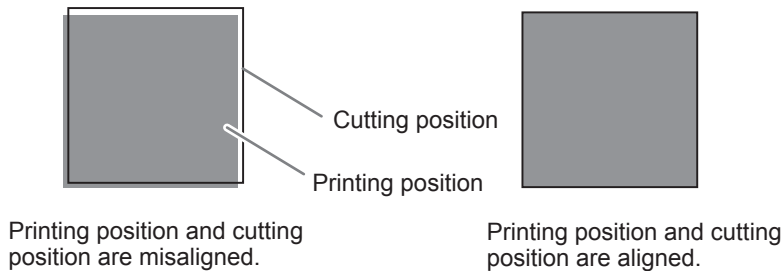

**4 [Cutting position and printing position are not aligned] Press [←] to select "YES."**

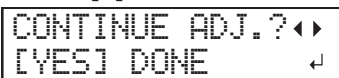

**[Cutting position and printing position are aligned] Press [→] to select "DONE."**

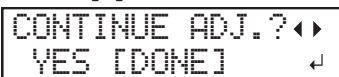

**5 Press [ENTER] to confirm your entry.**

If you select "YES," the test pattern (C&C2) for setting the correction values is printed and cut. Proceed to the next step. If you select "DONE," proceed to step **10**.

**6 Press [ENTER].**

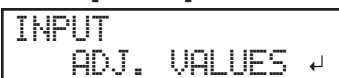

**7 Check the correction values from the test pattern (C&C2) condition.**

The point where the cutting line intersects the correction-value scale is the correction value. Check the scan direction (the direction of print head movement) and the feed direction (the media feed direction).

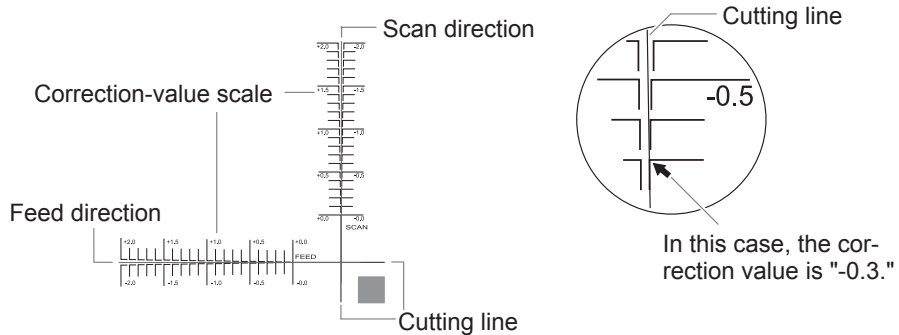
**8 Set the correction values for the feed direction "F" and the scan direction "S."**

① Press **[▲]** or **[▼]** to set the correction value for the feed direction (F).

```
F: +0.30 > -0.30mm
S: -0.40 > -0.20mm
```

② Press **[←]** or **[→]** to set the correction value for the scan direction (S).

```
F: +0.30 > -0.30mm
S: -0.40 > -0.20mm
```

③ When you have finished setting the correction values, press **[ENTER]**.

The test pattern (C&C1) is printed and cut again. Check the condition of the test pattern to check whether the printing position and the cutting position are aligned.

**9 [Cutting position and printing position are not aligned]**

Press **[←]** to select "YES."

```
REDO ADJ.? <>
[YES] DONE <
```

[Cutting position and printing position are aligned]

Press **[→]** to select "DONE."

```
REDO ADJ.? <>
YES [DONE] <
```

**10 Press **[ENTER]** to confirm your entry.**

If you select "YES," the test pattern (C&C1) is printed and cut again. Go back to step **7** and perform the setting again.

If you select "DONE," proceed to the next procedure.

## 10. Set the drying method and time after printing. (Separate setting P. 126)

- 1 Press [▲] or [▼] to select "ENABLE," "DISABLE," or "P&C."

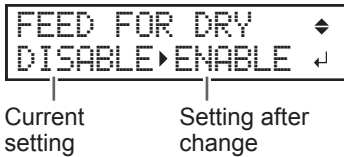

### MEMO: Drying method after printing

Set whether the media should be fed until the trailing edge of the printed area is put on the dryer after the 1st page is printed. To make sure to dry the entire printed area, select "ENABLE". To enable this function only for output data designed for printing and cutting, select "P&C." If "DISABLE" is selected, the trailing edge of the printing area is not fed to the dryer unless you continue with a subsequent printing operation.

- 2 Press [ENTER] to confirm your entry.

- 3 Press [▲] or [▼] to set the drying time.

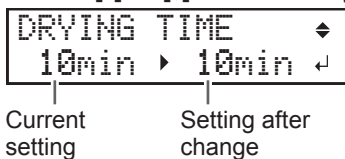

### MEMO: This setting is enabled for output data designed only for printing.

This setting is ignored for output data designed for printing and cutting. When the drying time has been set in the software RIP, priority is given to the software RIP's setting.

### MEMO: Drying time after printing

Set the drying time after the 1st page is printed. The next operation is not started until the set time passes.

### MEMO: Example of Setting Time (General Guide)

The setting time varies according to the settings such as the type of media and the printing quality.  
 Condition Non-coated vinyl chloride media  
 Setting time: About three minutes

- 4 Press [ENTER] to confirm your entry.

- 5 Press [▲] or [▼] to set the drying time.

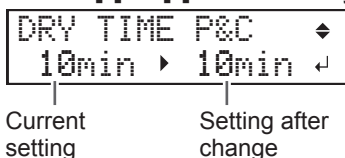

**MEMO:** This setting is enabled for output data designed for printing and cutting.

This setting is ignored for output data designed only for printing. This setting is also applied during printing and cutting with crop marks. Even if the drying time has been set in the included software RIP, priority is given to the setting on this machine.

- 6 Press [ENTER] to confirm your entry.

## 11. Save the settings as a preset.

- 1 Press [←] to select [SAVE].

```
PRESET      ◀▶
[SAVE]  NEXT  ↵
```

- 2 Press [ENTER] to confirm your entry.

If you select "NEXT" and press [ENTER], the screen in step 7 is displayed, and the settings you have selected up to this point are not saved as a preset. However, they will remain as the current setting values for the machine.

- 3 Press [▲] or [▼] to select a destination to save the preset.

You can select a name from NAME1 to NAME8.

```
SAVE TO      ◆
NAME1        ↵
```

- 4 Press [ENTER] to confirm your entry.

- 5 Set the name.

- ① Press [▲] or [▼] to select a character.
- ② Press [▶] to move to the next character.
- ③ Set the following characters in the same way.

You can enter up to 15 characters.

```
SET NAME      ◆▶
               ↵
```

- 6 Press [ENTER] to confirm your entry.

- 7 Press [MENU] to go back to the original screen.

```
COMPLETED
```

This completes the operation of the "MEDIA SETTING" menu.

## Canceling Batch Settings before They Are Completed

### Procedure

1 Press [MENU] during setup.

2 Press [←] to select "YES."

```

QUIT SETTING  ◀▶
[YES]  NO      ◀
  
```

3 Press [ENTER] to confirm your entry.

The screen shown below appears again.

```

MENU          ◀▶
MEDIA SETTING ◀
  
```

Selecting "NO" in step 2 returns you to the screen that was displayed when you pressed [MENU].

## Step 4 : Setting the Base Point

Set the base point in order to determine the area on the loaded media in which to print (the output area). The base point indicates the right edge of the output area. You can print without setting the base point, but setting the output area enables you to use media without being wasteful and also to print on the targeted location. Make this setting for each individual page. When the printing of one page finishes, the base point returns to its default value.

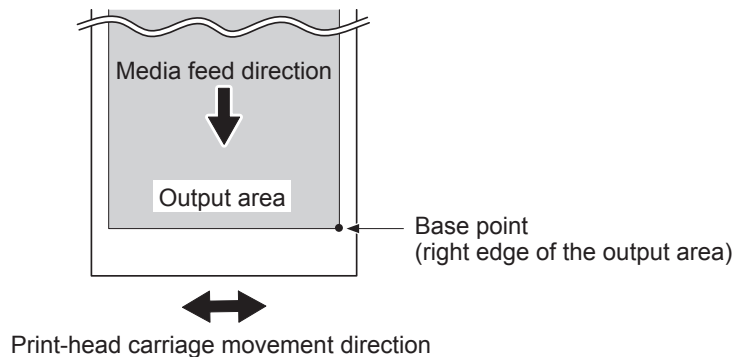

### MEMO

- Note that the left and right positions are not restored to their defaults for test patterns.
- If you are using the media take-up unit (sold separately), do not press [▲] after you finish setting up the media. Pressing [▲] will cause the machine to make an emergency stop in order to protect the motor.

## Procedure

- 1 Press [**←**], [**→**], [**▲**], or [**▼**] to move the center of the blade to the position that you want to set as the base point.

Only the cutting carriage moves.

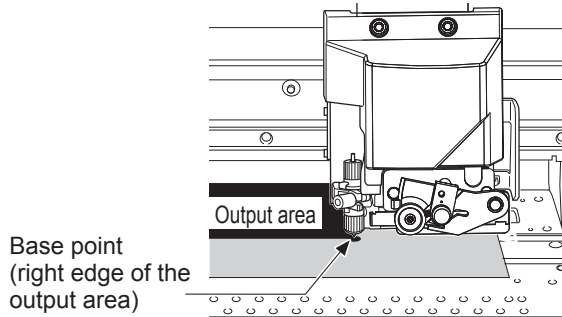

- 2 When the location is set, press [**FUNCTION**].

The screen shown below appears.



- 3 Press [**ENTER**] to confirm your entry.

[**BASE**] lights. When the screen displays the character "B" together with the printable width at the location (as shown in the following figure), setting is completed.

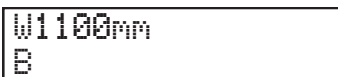

## Step 5 : Printing Tests and Normal cleaning

Before you carry out actual printing, perform a printing test to ensure no dot drop-out occurs. If dot drop-out occurs, clean the print heads (normal cleaning).

### MEMO

- This operation is unnecessary if you will only perform cutting.
- When performing printing tests successively, you can select "SCAN" (vertical printing) or "FEED" (horizontal printing) as the print position for the 2nd and later tests in comparison to the 1st test.

☞ P. 161 "Performing Printing Tests Arranged Horizontally"

## 1. Perform a printing test.

- 1 Press [**FUNCTION**].

- 2 Press [▼], then [▶] to display the screen shown below.



- 3 Press [ENTER].  
A test pattern is printed.

- 4 Check whether there is dot drop-out in the test pattern.



Missing blocks indicates dot drop-out.

- 5 If you have opened the front cover, close it.  
If no dot drop-out occurs, this operation is finished. Press [FUNCTION] to go back to the original screen.  
If the [PRESS THE ENTER KEY TO CONTINUE] message appears on the screen, press [ENTER].

## 2. Perform normal cleaning.

- 1 Press [FUNCTION].
- 2 Press [▼], [▶], then [▼] to display the screen shown below.

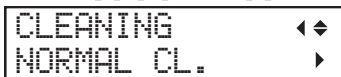

- 3 Check for the group with dot drop-out by viewing the printing-test results.

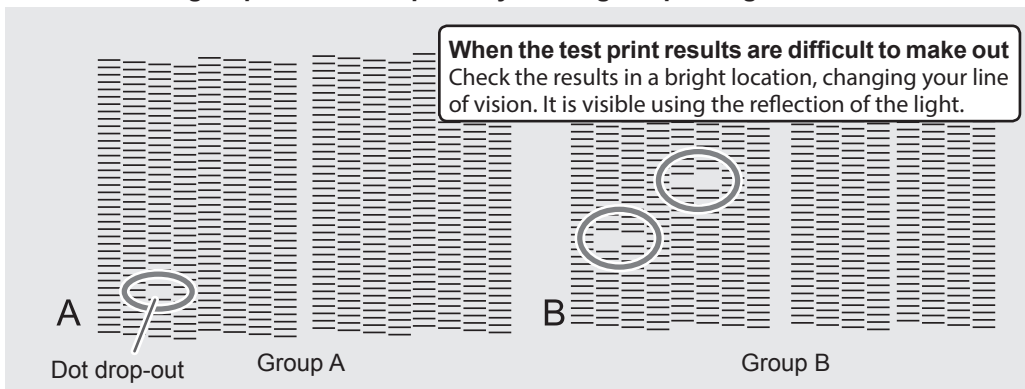

4 Press [▶].

5 Select the group of print heads to clean.

① Press [◀] or [▶] to select the group of print heads that is not to be cleaned.

```
NORMAL CL.  ◀◆▶
  AB          ↵
```

② Press [A] or [V] to get rid of the group display.

```
NORMAL CL.  ◀◆▶
  A_         ↵
```

③ Repeat steps ① and ② to display only the group of print heads that requires cleaning.

Only the displayed groups will be cleaned. If A and B are displayed, they will both be cleaned.

6 Press [ENTER].

The screen shown below appears, and then cleaning starts. The (approximate) remaining time for the procedure is displayed on the screen. (The display shown below is an example. "01:45" = "1 minute and 45 seconds")

```
CLEANING...
>>          01:45
```

When finished, the screen shown below appears again.

```
NORMAL CL.  ◀◆▶
  AB          ↵
```

7 Press [FUNCTION] to go back to the original screen.

8 Repeat step 1 to make sure the dot drop-out has been corrected.

#### MEMO

When performing continuous test prints, there is no need to set the base point from the second print onward. However, the base point will be restored to its default and it will be necessary to set it again if any of the following operations are made between printing operations.

- Sheet cutting
- Printing and cutting of output data you created
- Setup cancellation

If the problem persists, try performing normal cleaning again. If the printer has been used for a long period, dot drop-outs may not be fixed even after performing normal cleaning two or three times. If this is the case, clean using a different method.

☞ P. 88 "When Normal Cleaning Is Not Effective"

## Step 6 : Starting Output

### Before Starting Output

- Remove just the pouch tray for the white ink, shake the pouch tray 50 times (about 20 seconds), and then reinsert this pouch tray.
- The pouch trays for colors other than white do not need to be shaken before every operation, but be sure to shake them when installing new ones.

The precipitation of the ingredients in the ink disables printing in normal color. So that the ink mixes well, shake the pouch tray horizontally with a stroke length of around 5 cm (2 in.) from each end of the tray. The ingredients in white ink tend to settle. Each day, before starting the day's operations, be sure to carry out the above steps. Allowing the ink to stand without carrying out these steps can cause the settled material to harden, resulting in malfunction or other problems.

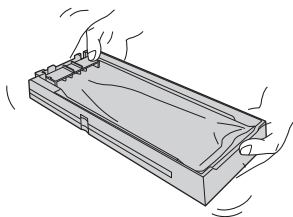

#### IMPORTANT

- Do not remove the ink pouches. Shake the entire pouch tray. Removing the ink pouches may lead to the ink leaking.
- Before shaking, wipe off any ink from around the mouth of the ink pouch. If you do not wipe off the ink, it may splatter when you shake the pouch tray.
- When you have finished mixing the ink, reinsert the pouch tray immediately. Taking time to reinsert the pouch tray will adversely affect the ink path.
- Even if you rarely use white ink, shake the pouch tray for the white ink 50 times (about 20 seconds) once a week.

#### MEMO

Check that you can perform communication through the Ethernet interface.

Communication is possible if the status LED on the Ethernet connector located on the side of the printer is lit in green.

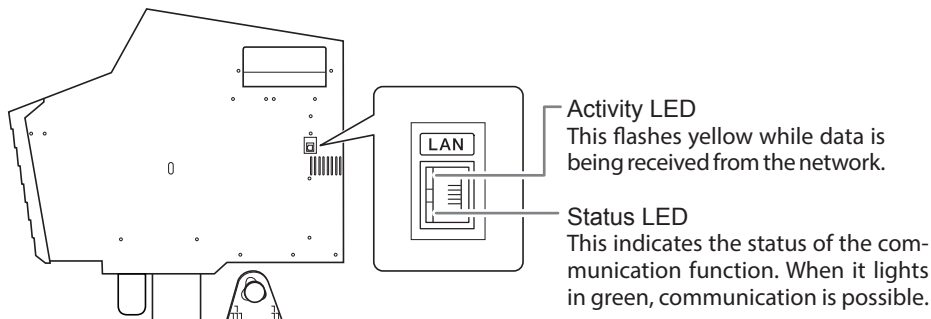

**⚠ CAUTION**

**Never touch the print-head carriage while output is in progress.**

The print-head carriage moves at high speed. Coming into contact with the moving carriage may cause injury.

**Procedure**

- 1 **Close the front cover.**
- 2 **Check that [SETUP] is lit.**  
If [SETUP] is not lit, the loading lever has been raised. Lower the loading lever.
- 3 **Wait until [HEATER] stops flashing and stays lit.**

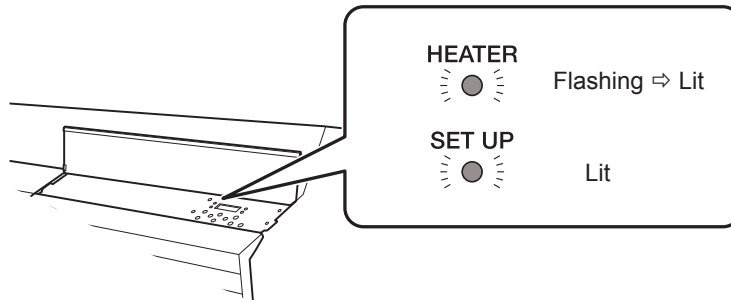

- 4 **Check that the screen shown below (the top menu) is displayed.**  
If the top menu is not displayed, press [MENU].  
If the [PRESS THE ENTER KEY TO CONTINUE] message appears on the screen, press [ENTER].

W1100mm

- 5 **Send the output data from the computer.**  
Create the output data using drawing application software. For information on how to create the data, refer to the documentation of your application software.  
To perform cutting or printing and cutting, you have to include the cutting data in the output data. For information on how to create cutting data, refer to the documentation for the included software RIP. If using the white ink, refer to "Special Color Ink Guide."

**MEMO**

When you send the output data, "FILLING" or "CLEANING" may be displayed on the screen. These indicate the preparation operations performed before output. Output will begin after the time displayed on the screen elapses.

### **IMPORTANT: Output Is Not Possible in These Situations**

- The machine does not run when a cover (front, left, or right) is open.
  - Never open a cover (front, left, or right) while output is in progress. Doing so interrupts printing.
  - Data from the computer is not accepted when [SETUP] is dark.
  - Printing does not start until [HEATER] lights. (If the print heater and dryer are set to "OFF," printing is possible even if [HEATER] is not lit.)
- ☞ P. 123 "Settings for the Media Heating System"
- Data from the computer is not accepted when you are not at the top menu.

### **IMPORTANT: Points that must be observed**

- When you are performing printing, be sure to attach the media clamps. Otherwise, the edges of the media may warp and catch on the print heads.
- During output, do not touch the media. Doing so may obstruct the media feed or cause the media to rub against the print heads, which may result in a paper jam or damage to the heads.
- Keep the loading lever raised when the machine is not in use.

### **IMPORTANT: When not using the machine, remove any media and store it in a suitable environment.**

- If the machine is left with the media loaded, the media may be damaged, which may adversely affect printing. When not using the machine, remove any media and store it in a suitable environment.

# Basic Settings for Cutting

## Hints and Tips for Cutting Settings

- Setting the [PREFEED] menu item to "ENABLE" makes the machine automatically feed out media and take it up again before cutting. This makes it unnecessary to run out media to the rear of the machine before the operation.
  - ☞ P. 60 "Preventing Pulling of the Media with Undue Force"
- Switching off the print heater and dryer and allowing the temperature to cool before performing cutting can yield results that are more stable.
  - ☞ P. 124 "Making the Temperature Setting for the Media Heating System"
- The tip of the blade holder cap may scrape and soil or damage the printed surface. If this happens, increase the amount of blade extension.
  - ☞ P. 144 "Accurately Adjusting the Cutting-in Amount"

## Important Note on Cutting

***When you are performing cutting only, do not use the media clamps.***

When you are performing cutting only, remove the media clamps or move them to locations where they do not clamp the media.

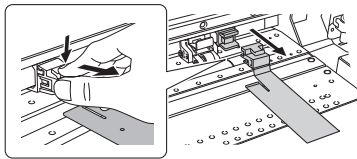

***When using roll media and only performing cutting, allow the media to hang down from the rear of the machine. (Or set the [PREFEED] menu to "ENABLE.")***

This prevents motor errors and the roll falling from the machine due to the media being pulled with excessive force.

For the [PREFEED] menu, see the following section. ☞ P. 60 "Preventing Pulling of the Media with Undue Force"

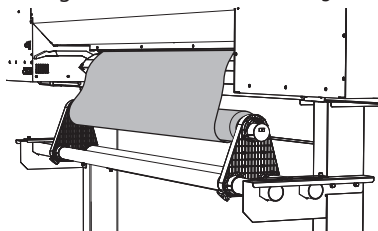

***When you are performing printing and cutting, allow the ink to dry sufficiently before starting cutting.***

Adjust the drying time to match the media.

- ☞ P. 127 "Setting the Drying Time after Printing (When Only Printing)"
- ☞ P. 128 "Setting the Drying Time after Printing (When Printing and Cutting)"

## Preventing Pulling of the Media with Undue Force

### Procedure

- 1 Press [MENU].
- 2 Press [▲] to display the screen shown below.

```
MENU          ◀◆
CUTTING MENU  ▶
```

- 3 Press [▶] once, and then press [▲] several times to display the screen shown below.

```
CUTTING MENU ◀◆
PREFEED      ▶
```

- 4 Press [▶] to display the screen shown below.

```
PREFEED      ◀◆
DISABLE▶DISABLE▶
```

- 5 Press [▲] or [▼] to select "ENABLE."

```
PREFEED      ◀◆
DISABLE▶ENABLE▶
```

- 6 Press [ENTER] to confirm your entry.
- 7 Press [MENU] to go back to the original screen.

### Description

This feeds out media according to the size of the data sent from the computer before performing cutting. This makes it unnecessary to turn the media flanges by hand to feed out media every time you perform cutting. Note, however, that this feeds out media even when you are performing printing only, so set it to "DISABLE" when not needed.

When the prefeeding has been set in the software RIP, priority is given to the software RIP's setting.

### Default Settings

[PREFEED]: DISABLE

## Setting the Cutting Test and the Blade Force

For high-quality cutting, we recommend carrying out a cutting test to check the cutting quality for the media before you perform actual cutting. Adjust the blade force depending on the cutting quality.

### 1. Carry out the cutting test.

① Close the front cover.

② Press [←], [→], [▲], or [▼] to move the cutting carriage to the location where you want to carry out the cutting test.

You can freely set the location for the cutting test.

③ Press [FUNCTION].

④ Press [▼] several times to display the screen shown below.

```
FUNCTION  ◀◆
CUT CONFIG ▶
```

⑤ Press [→] to display the screen shown below.

```
CUT CONFIG  ◀◆
TEST CUT    ↵
```

⑥ Press [ENTER].

The test pattern is cut.

### 2. Set the blade force.

① Press [▼] to display the screen shown below.

```
CUT CONFIG  ◀◆
FORCE       ▶
```

② Press [→] to display the screen shown below.

```
FORCE      ◀◆
50gf ▶ 50gf ↵
```

- 3 **Peel off the cut shapes to verify the cutting quality.**

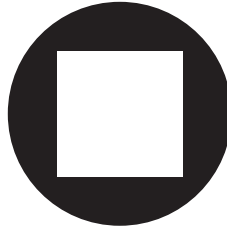

**[Two shapes are peeled off separately]**

You do not need to perform the setting because the blade force is appropriate.

**[Two shapes are peeled off together/backing paper is also cut]**

Proceed to the next step to set the blade force.

- 4 **Press [▲] or [▼] to select a value.**  
**[Two shapes are peeled off together]**  
Raise the blade force.  
**[Backing paper is also cut]**  
Reduce the blade force.

- 5 **Press [ENTER] to confirm your entry.**

- 6 **Press [FUNCTION] to go back to the original screen.**

- 7 **Repeat step 1 to check whether the correction was successful.**

At the [CUT CONFIG] menu, you can also make settings for other cutting conditions in addition to the blade force. Refer to the following page.

☞ P. 142 "Fine-tuning the Cutting Conditions"

# Printing and Cutting with Crop Marks

## What Is Printing and Cutting with Crop Marks?

"Crop marks" are marks used to align positions. If you are removing the printed media and loading it again in order to cut it (for example, if you are processing the media such as laminating after printing, and then loading this media again for cutting), you have to align the printing and cutting positions.

By printing the data together with crop marks, you can make it possible to align the positions using the crop marks when you load the media again to cut it.

In this manual, this printing method is referred to as "printing and cutting with crop marks."

### Flow of Printing and Cutting with Crop Marks

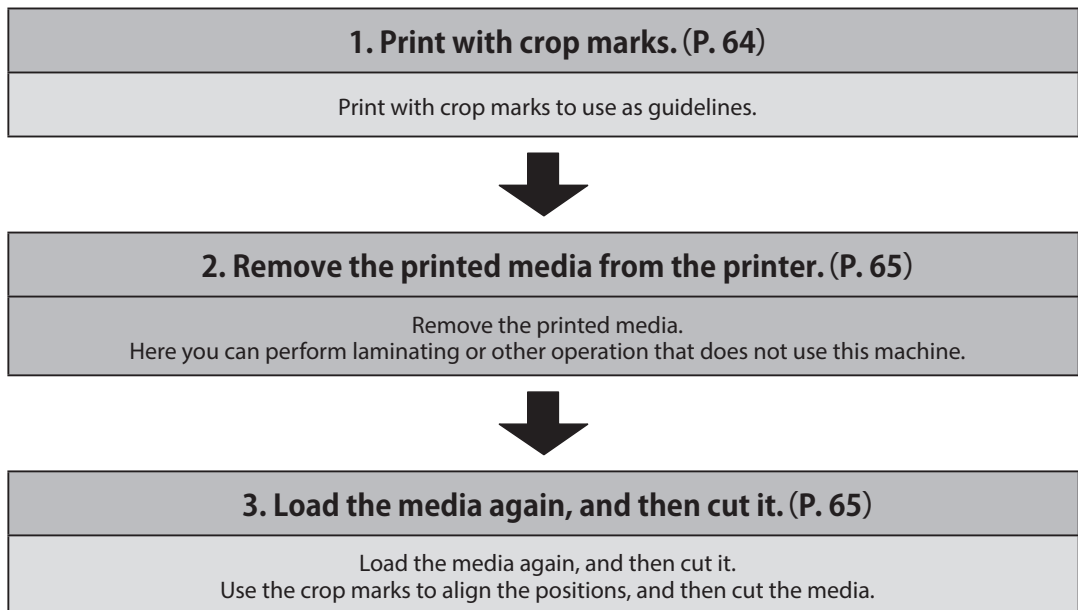

## How to Print and Cut with Crop Marks

### 1. Print with crop marks.

**1 Use your software RIP to configure the settings to print with crop marks.**

For information on how to make the settings, refer to the documentation for the software RIP you are using.

**MEMO**

When printing with crop marks, a margin to use in detecting the crop marks is required. Set the margins according to the figure shown below. You can set the margin value with the software RIP you're using.

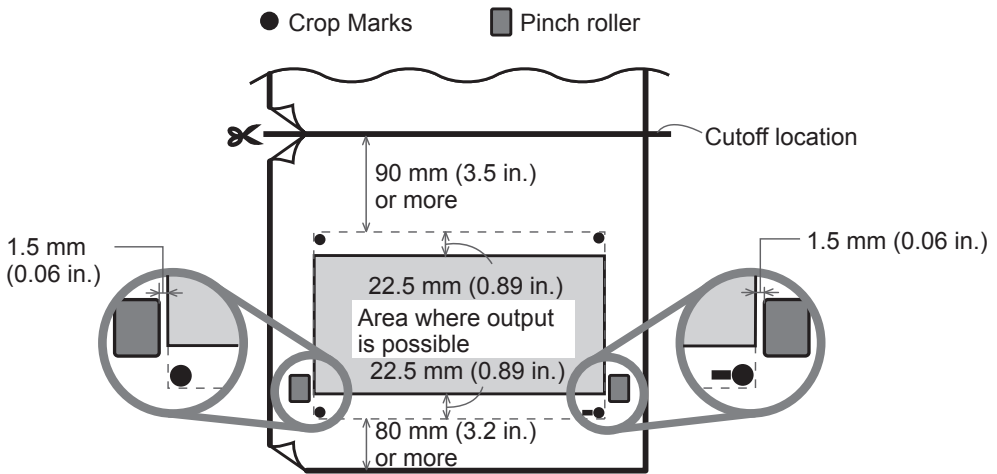

**IMPORTANT**

Alignment marks and symbols drawn using graphics software cannot be used as crop marks.

**2 Prepare to print, and then send the printing data from the computer.**

☞ P. 28 "Basic Printing Method"

The crop marks are printed as shown below.

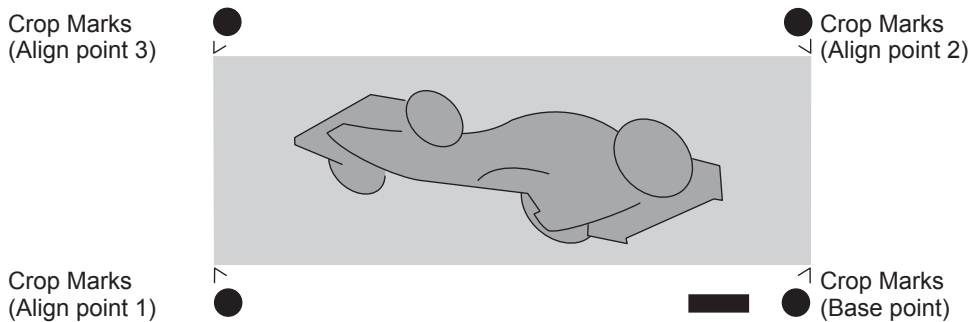

## 2. Remove the printed media from the printer.

Remove the printed media. Here you can perform laminating or other operation that does not use this machine.

## 3. Load the media again, and then cut it.

### 1 Use your software RIP to configure the settings to detect crop marks during cutting.

The crop marks are automatically detected during cutting, and the cutting position is aligned with the printing position. For information on how to make the settings, refer to the documentation for the software RIP you are using.

### 2 Load the media that you removed in step 2. in the machine again, and then perform setup.

☞ P. 74 "Loading Sheet Media (Setup of Media)"

#### Point

Place the two crop marks at the front on the blade protector.

#### Good

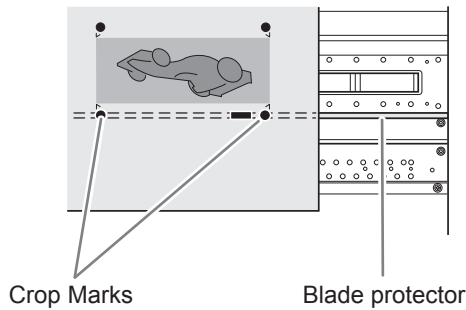

Ensure that the crop marks are not angled by more than 5 degrees. Otherwise alignment becomes impossible.

#### Not Good

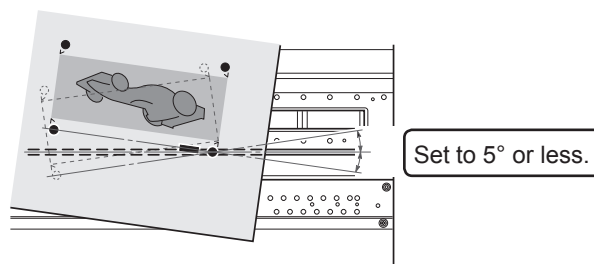

- 3 Press [▲] or [▼] to move the media so that the two crop marks at the front are placed on the blade protector.

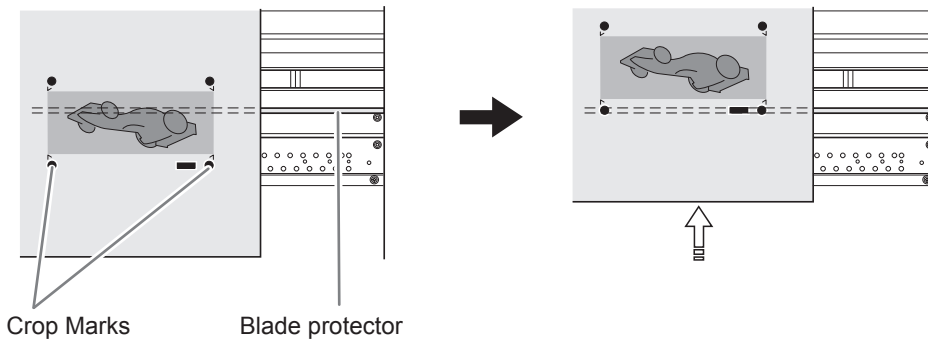

- 4 Set the base point.

☞ P. 52 "Step 4 : Setting the Base Point"

- 5 Send the cutting data from the computer.

The crop marks are automatically detected to align the positions and cut the media.

## Printing and Cutting with Crop Marks: Basic Troubleshooting

### Automatic Detection of Crop Marks Fails

If the automatic detection of crop marks fails, the screen shown below appears and operation stops.

```
CROPMARK ERROR
NOT FOUND
```

Press any key to return to the previous screen. Reload the media, and then send the data again.

#### Possible Causes

- The crop marks cannot be detected appropriately because of the effect of media warping.
- The crop mark detection error is large due to the large size of the media.

#### Countermeasures

- Avoid printing and cutting with crop marks for media that is warped.
- When you want to use lengthy media, we recommend performing output with the data separated into sizes that are as short as possible.
- If the crop marks cannot be detected automatically, you can perform alignment manually.

☞ P. 152 "Aligning Positions Manually"

---

## If You Want to Stop Crop Mark Detection before It Is Finished and Start Cutting

---

### Procedure

---

**1 Press [PAUSE] during detection of crop marks.**

The screen shown below appears, and crop mark detection stops. Depending on the content of the data, some time may pass before detection actually stops.

```
CANCEL CROPMARK
DETECTION?↵
```

**2 Press [ENTER].**

Detection stops, and cutting begins.

If you press [PAUSE] once more without pressing [ENTER], detection will start again. Hold down [PAUSE] for one second or longer to cancel all output operations.

☞ P. 79 "Pausing and Canceling Output"

---

## If You Want to Stop the Operation before It Is Finished

---

You can cancel the printing, crop mark detection, or cutting operation before it is finished by holding down [PAUSE] for one second or longer.

☞ P. 79 "Pausing and Canceling Output"

---

## If the Printing and Cutting Positions Are Offset

---

If the printing position and cutting position are misaligned even after detecting crop marks, you can correct the misalignment.

☞ P. 154 "Correcting Misalignment for Printing and Cutting When Using Crop Marks"

# Ink Pouch/TR Cleaning Liquid Pouch Replacement

## Out-of-ink Warnings

☞ P. 70 "Ink Pouch Replacement"

### If Using 8 Colors (CMYKLcLmLkW) or 7 Colors (CMYKLcLmLk)

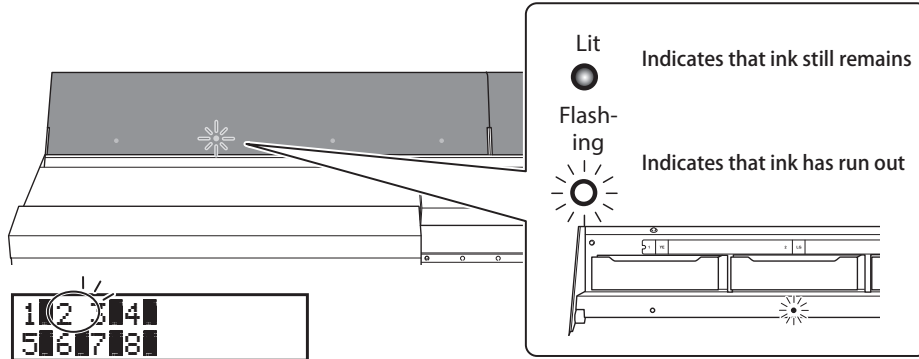

If an ink runs out, the numbers of the color that has run out flash.

When an ink pouch runs out, printing pauses (unless the factory default settings have been changed) and a warning beep sounds.

### If Using 4 Colors (CMYK)

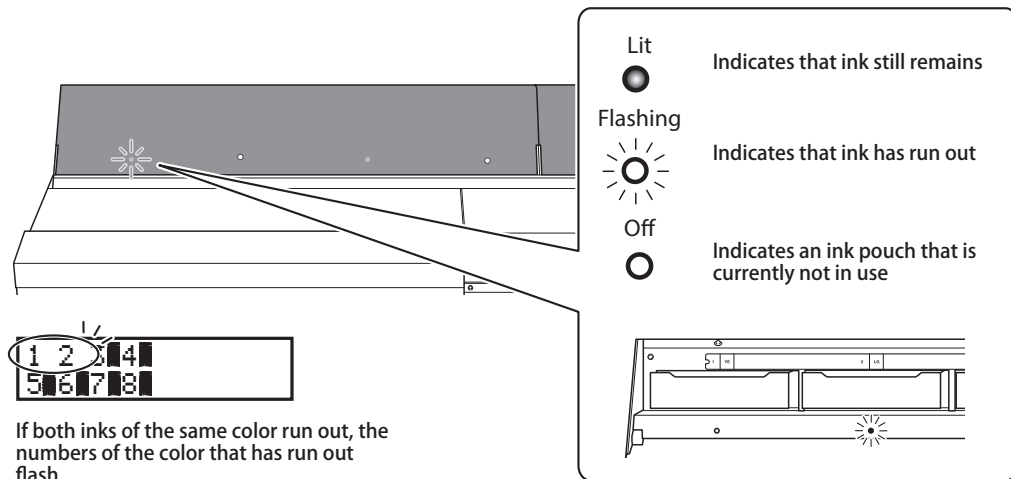

If both inks of the same color run out, the numbers of the color that has run out flash.

If one ink cartridge of the same color runs out, the machine continues printing using the other ink cartridge. When all ink cartridges of the same color run out, printing pauses and a warning beep sounds.

## Out-of-TR-cleaning-liquid Warnings

If the TR cleaning liquid runs out, the cleaning liquid slot light flashes. After some time, a message requesting that you replace the TR cleaning liquid will be displayed on the screen.

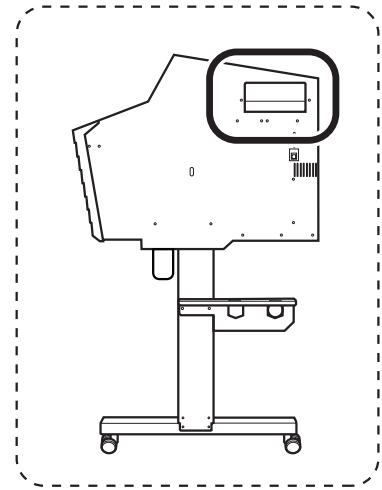
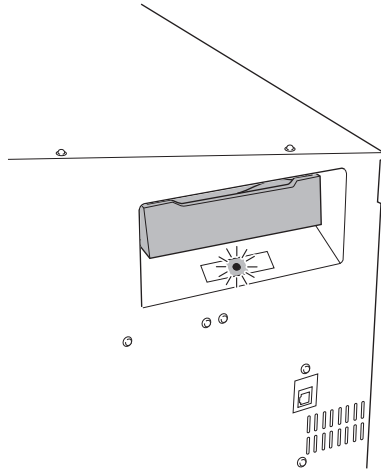

CHANGE CL-LIQUID  
FOR WIPER↵

\* "CL-LIQUID FOR WIPER" indicates the TR cleaning liquid.

## Ink Pouch Replacement

### **⚠ WARNING**

**Never store ink, cleaning liquid, or discharged fluid in any of the following locations.**

- Any location exposed to open flame
- Any location where high temperature may occur
- Near bleach or any other such oxidizing agent or explosive material
- Any location within the reach of children

Fire may be a danger. Accidental ingestion by children may pose a health hazard.

### **Precautions regarding ink pouch replacement**

- Be sure to replace each pouch with an item of identical type and color.
- Never use an ink pouch that has already been used in another machine even if it is an identical type.
- Never mix different types of items.
- Never leave the machine with a pouch tray removed. The print heads may become clogged.
- Do not insert or remove pouch trays unless necessary. Ink may leak.
- Take care not to drop ink pouches.

### 手順

#### **1** Open the ink slot cover.

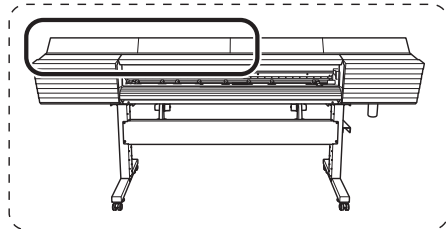
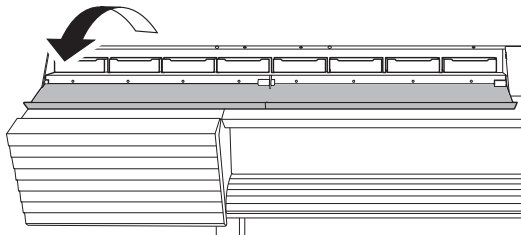

#### **2** Remove the pouch tray for the color that you will replace.

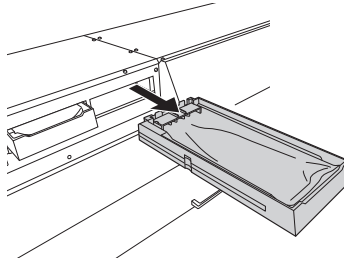

**3 Remove the ink pouch from the pouch tray.**

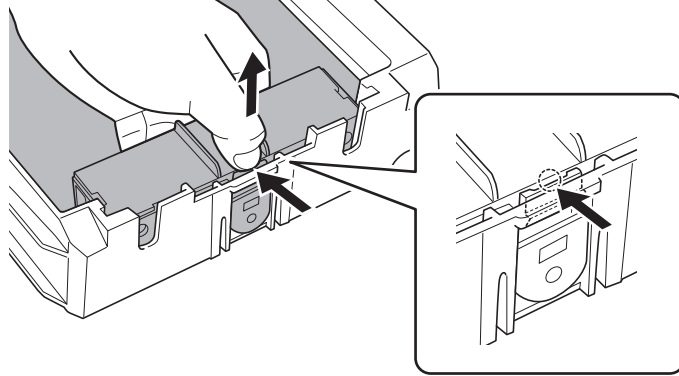

**4 Gently shake the new ink pouch.**

During storage, the ink components may have precipitated. When replacing an ink pouch, gently shake the new ink pouch to mix its contents before setting the ink pouch in the tray.

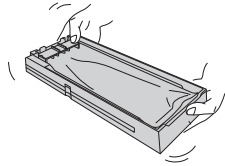

**5 Set the new ink pouch in the pouch tray.**

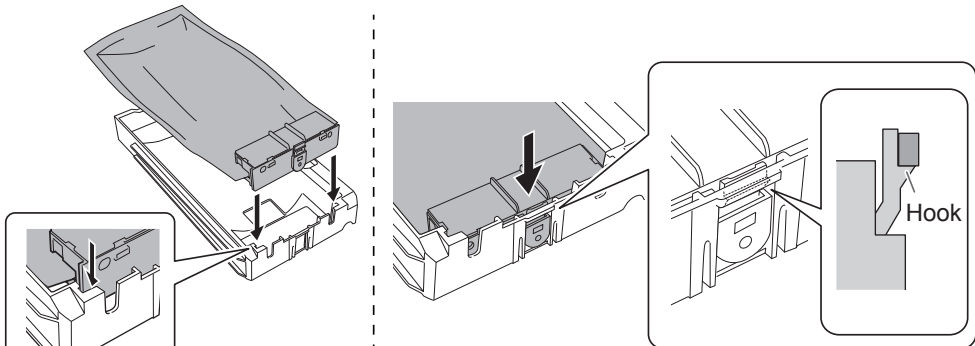

Check that the hook has caught.

**6 Set the pouch tray in the ink slot.**

Insert the ink tray as far as it will go.

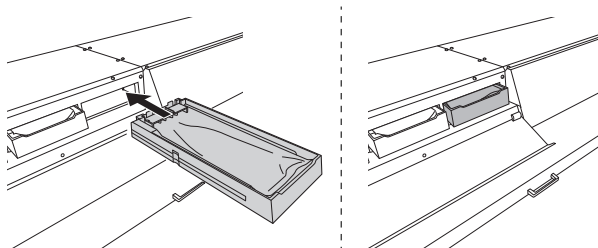

**7** Close the ink slot cover.

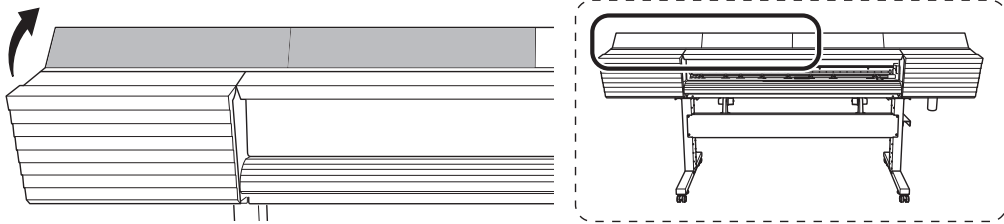

**TR Cleaning Liquid Pouch Replacement**

**⚠ WARNING**

**Never store ink, cleaning liquid, or discharged fluid in any of the following locations.**

- Any location exposed to open flame
- Any location where high temperature may occur
- Near bleach or any other such oxidizing agent or explosive material
- Any location within the reach of children

Fire may be a danger. Accidental ingestion by children may pose a health hazard.

When the TR cleaning liquid runs out, the following message will be displayed. Follow the procedure shown below to replace the TR cleaning liquid pouch.



\* "CL-LIQUID FOR WIPER" indicates the TR cleaning liquid.

手順

**1** Remove the pouch tray from the cleaning liquid slot.

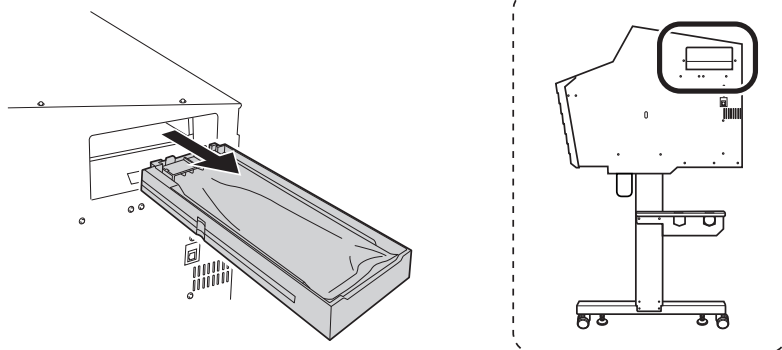

- 2** Remove the TR cleaning liquid pouch from the pouch tray.

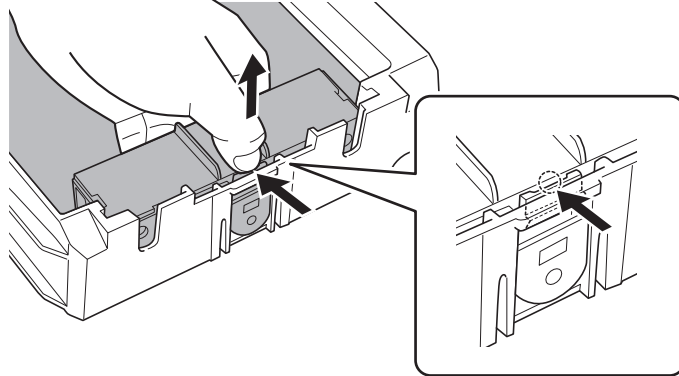

- 3** Set the new TR cleaning liquid pouch in the pouch tray.

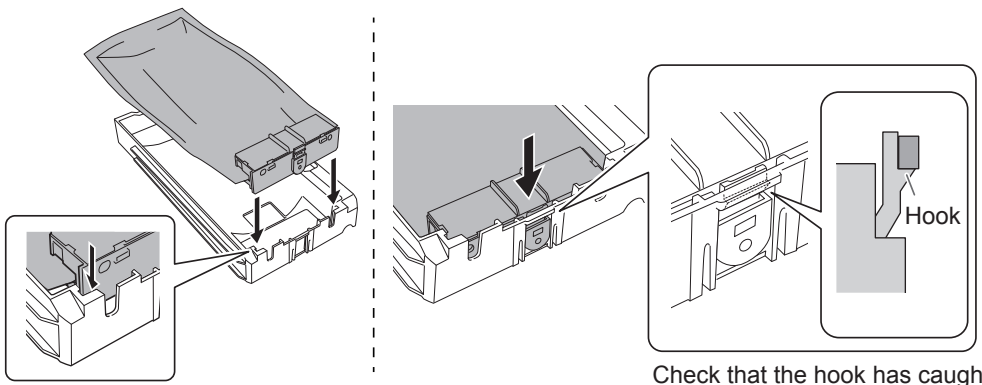

- 4** Set the pouch tray in the cleaning liquid slot.  
Insert the ink tray as far as it will go.

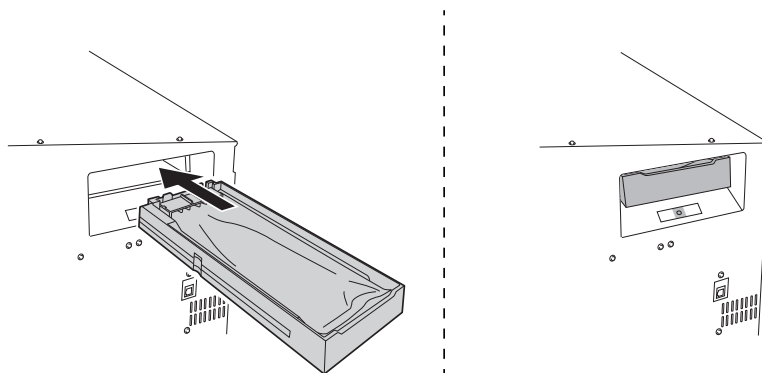

# Other Basic Operations

## Loading Sheet Media (Setup of Media)

Load the sheet media on the printer. When you have finished loading the media, [SETUP] lights. This work is referred to as "Setup of Media."

### 1. Pull out the media over the platen.

① Open the front cover.

② Move the media clamps to the left and right ends respectively.

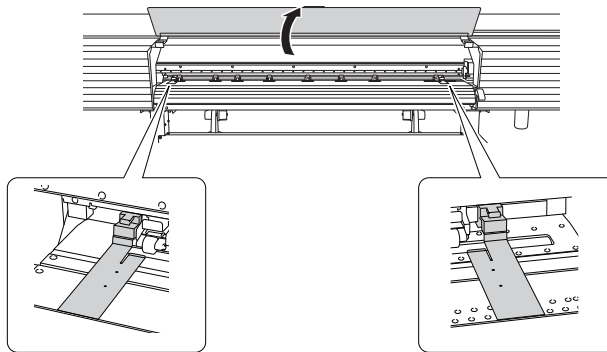

③ Loosen the retaining screws of the media holders, and then draw them to the left and right ends respectively.

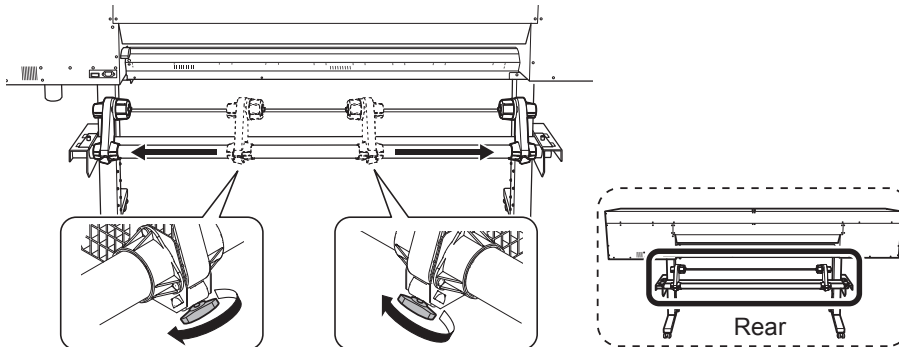

- 4 Pass the leading edge of the media between the pinch rollers and the grit rollers.

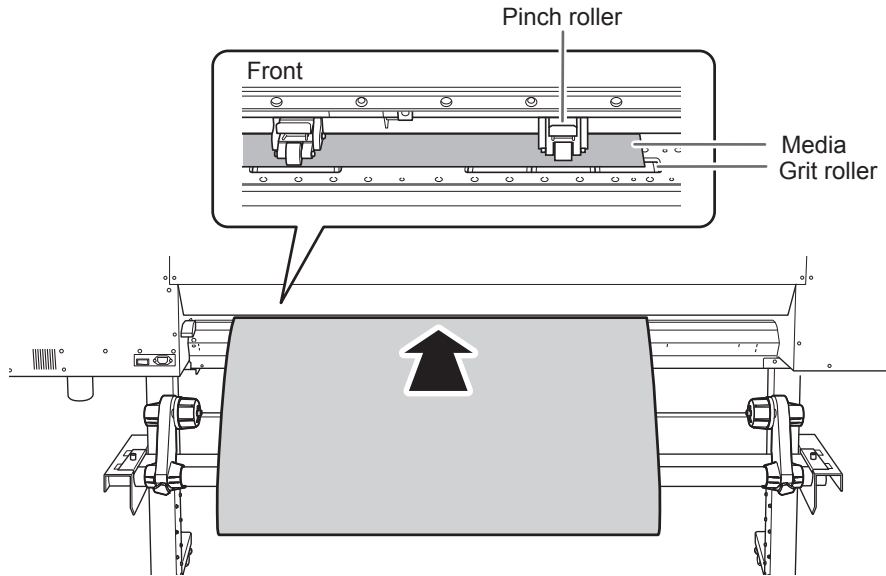

- 5 Make sure the front cover is open.

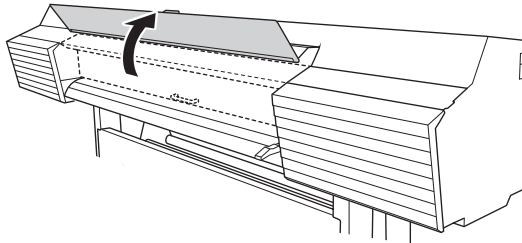

- 6 Lower the loading lever (rear).

The media is held in place.

At this time, the message "CLOSE FRONT COVER" is displayed on the screen, but continue operations without closing the front cover.

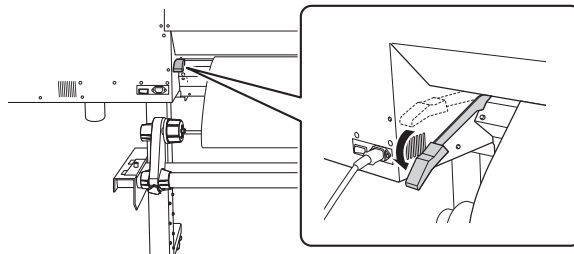

- 7 (Move to the front of the printer.) Gently hold down the media and raise the loading lever (front).**

The media is released.

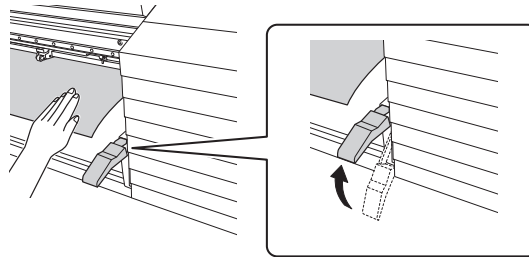

- 8 Pull out the media over the platen.**

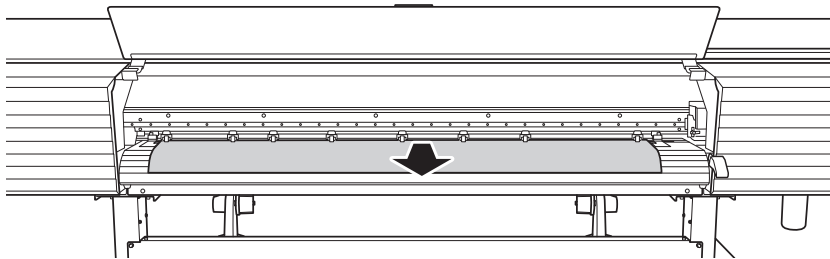

## 2. Secure the media in place.

- 1 Make sure both edges of the media are above the grit rollers.**

Be sure to place the right edge of the media on the right-end grit roller.

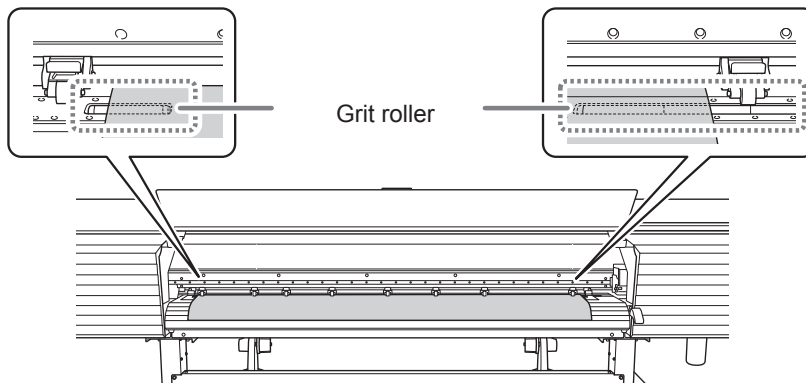

**2 Place the left and right pinch rollers (affixed with blue stickers) on both edges of the media.**

Position them approximately 10 mm (0.39 in.) from each edge of the media.

Left pinch roller (affixed with a blue sticker)      Right pinch roller (affixed with a blue sticker)

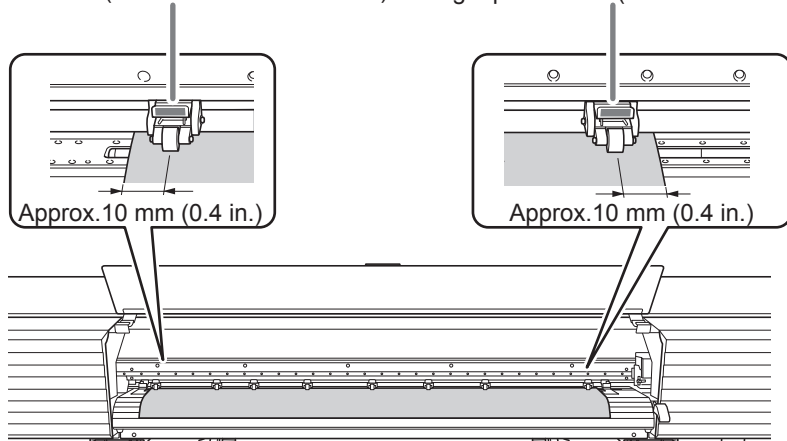

**3 Place the middle pinch rollers over all the remaining grit rollers covered by the media.**

There are grit patterns wherever there are grit rollers. Be sure to remove the remaining middle pinch rollers.

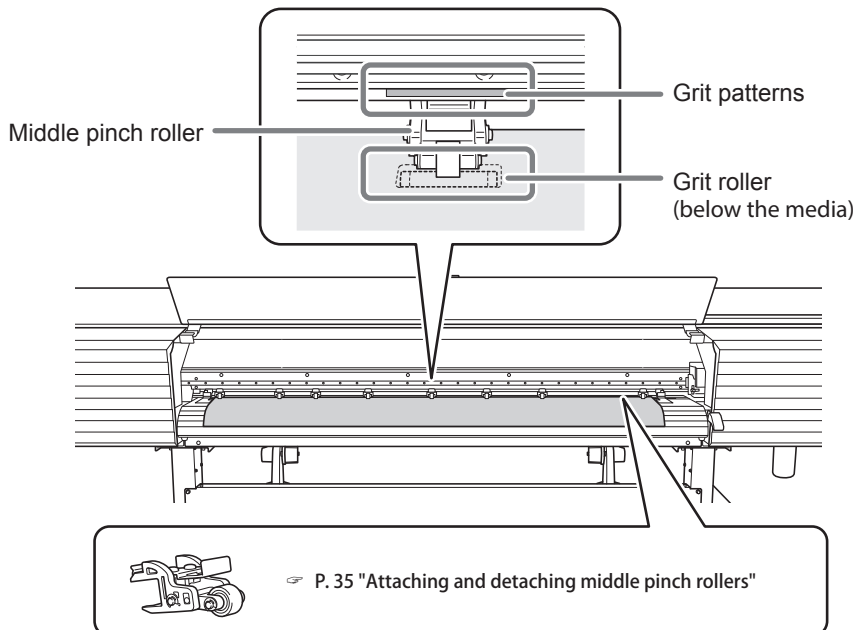

**4 Straighten the media.**

Align the media with the line indicated with the arrow in the following figure.

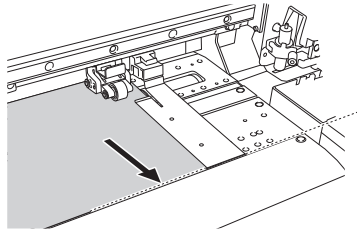

**5 Lower the loading lever (front).**

The media is held in place.

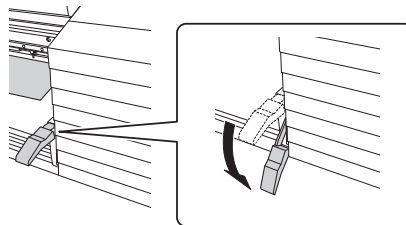

**6 Line up the edges of the media with the centers of the holes of the media clamps (left and right).**

When you are performing cutting only, do not use the media clamps.

☞ P. 59 "Important Note on Cutting"

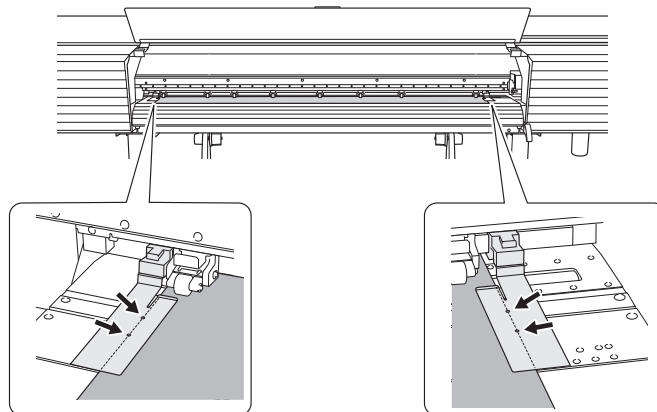

**7 Close the front cover.**

If the [PRESS THE ENTER KEY TO CONTINUE] message appears on the screen, press [ENTER].

When the front cover is closed, the print-head carriage moves and detects the width of media. This operation is called initialization. When initialization ends, [SETUP] on the operation panel lights, and the printable width is displayed on the screen. This completes the setup of the media.

## Pausing and Canceling Output

You can pause and cancel output before it finishes.

### IMPORTANT

We do not recommend resuming printing because horizontal stripes are produced at the place where printing was paused.

### Procedure

- 1 Press [PAUSE] before printing finishes.  
This pauses the printing operation.
- 2 Press [PAUSE] again to resume printing.  
To cancel printing, go the next step without pressing [PAUSE].
- 3 When the screen shown below appears, hold down [PAUSE] for one second or longer.

```
TO CANCEL, HOLD
DOWN PAUSE KEY
```

This cancels the printing operation.

- 4 Stop sending the output data from the computer.

## Cutting Off the Media

### Procedure

- 1 Remove the left and right media clamps.

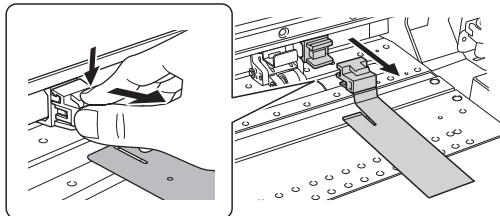

- 2 Close the front cover.
- 3 Check that [SETUP] is lit.
- 4 Press [FUNCTION].
- 5 Press [▼] several times to display the screen shown below.

```
FUNCTION      ◀▶
SHEET CUT    ↵
```

- 6 Press [ENTER].**  
The media is cut off.

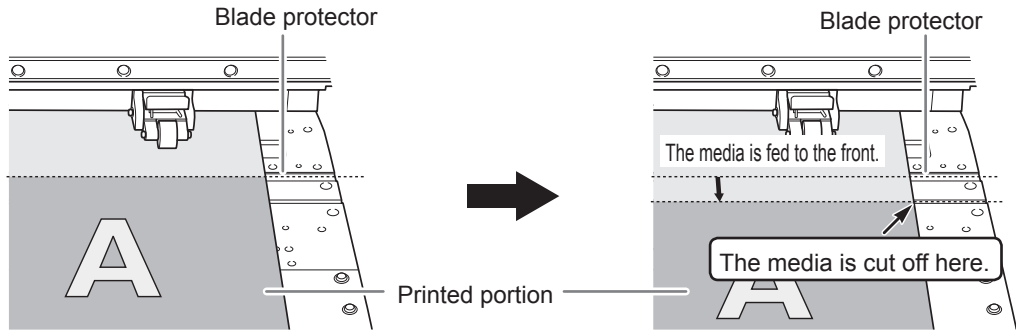

You can configure settings in the software RIP for automatic media cutoff after output has finished. For information on how to configure the settings, refer to the documentation for the software RIP you are using.

### Cutoff Operations

When the media clamps are attached, the screen shown below appears. Open the front cover, remove the left and right media clamps, and then press [ENTER].



- Be sure to remove the media clamps. If you attempt to perform the cutoff operation while the media clamps are attached, the machine will detect them and interrupt the operation.
- Even if you enable the automatic media-cutoff function in the software RIP, if the media clamps are attached, the machine will detect them and interrupt the operation.
- When performing cutoff, do not use [▲] to pull the media back. Unless the end of the media has been pulled out to a location in front of the platen, cutoff may not be performed smoothly.

### Give Attention to the Media Composition

- For some types of media, cutoff is not possible.
- Some types of media may remain on the platen after cutoff. If the media remains on the platen, remove it by hand.

# Chapter 3 Maintenance

Daily Maintenance .....	82
Cleaning .....	82
When "EMPTY DRAIN BOTTLE" Is Displayed .....	83
Disposing of Discharged Fluid.....	84
Timing of Print Head Care and Maintenance .....	86
When Normal Cleaning Is Not Effective.....	88
Medium/Powerful Cleaning.....	88
Manual Cleaning.....	90
Manual Cleaning.....	90
If Colors Are Uneven.....	97
Mixing the Ink by Shaking the Pouch Tray .....	97
Damper Cleaning (When Uneven Color Issues Occur with White Ink) .....	97
When Dot Drop-outs/Uneven Colors Are Not Fixed.....	100
Super Cleaning.....	100
Replacing Consumable Parts .....	104
Replacing the Wiper .....	104
Cleaning the Wiper Tray and Replacing the Tray Pads.....	107
Replacing the Blade .....	111
Replacing the Separating Knife.....	114
When Not in Use for a Prolonged Period.....	117
Keep Performing Maintenance.....	117
Disposing of Discharged Fluid.....	117

# Daily Maintenance

## Cleaning

### ⚠️ WARNING

Never use a solvent such as gasoline, alcohol, or thinner to perform cleaning.

Doing so may cause a fire.

### ⚠️ CAUTION

Before attempting cleaning, switch off the sub power and wait until the platen and dryer cool (approximately 30 minutes).

Sudden movement of the machine may cause injury, or hot components may cause burns.

Wipe away any ink or grime on the media path and other areas as part of the daily cleaning procedure. Pinch rollers, grit rollers, and the platen are particularly prone to the buildup of grime. Clean by wiping with a cloth moistened with neutral detergent diluted with water then wrung dry.

### IMPORTANT

- This machine is a precision device and is sensitive to dust and dirt. Perform cleaning on a daily basis.
- Never attempt to oil or lubricate the machine.

#### Pinch rollers

Periodically wipe away any grime. Failure to clean this part properly may result in the transfer of grime to the surface of media.

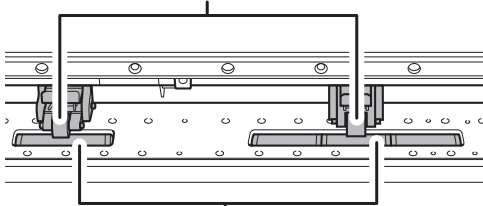

#### Grit rollers

Remove buildup of media scraps and other material using a brush. Never use a metal brush.

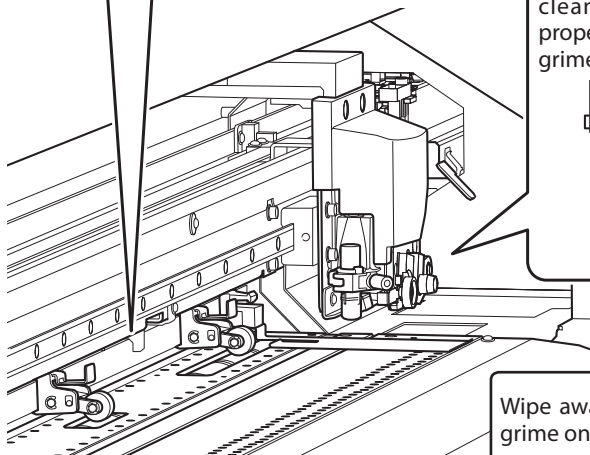

#### Separating knife roller

This part is prone to paper dust buildup. Periodically wipe the area clean. Failure to clean this part properly may result in the transfer of grime to the surface of media.

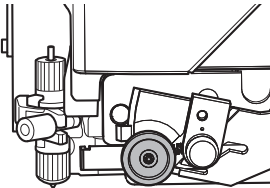

Wipe away any buildup of ink or grime on the media path.

## When "EMPTY DRAIN BOTTLE" Is Displayed

The message shown below appears when a certain amount of discharged fluid has collected in the bottle.

```
EMPTY
DRAIN BOTTLE ↵
```

### Procedure

- 1 When the message shown below appears, detach the bottle, discard the discharged fluid to empty it.

```
EMPTY
DRAIN BOTTLE ↵
```

#### IMPORTANT

When you remove the drain bottle, a few drops of discharged fluid may come out of the machine. Exercise caution to prevent this fluid from soiling your hands or the floor.

#### ⚠ CAUTION

**Before you detach the drain bottle, be sure to wait for the screen to display [EMPTY DRAIN BOTTLE.] After discarding the discharged fluid, promptly attach the drain bottle to the machine.**

Failing to follow this procedure may cause discharged fluid to flow out of the tube and spill, soiling your hands or the floor.

- 2 Quickly attach the emptied drain bottle to the machine once more.
- 3 Press [ENTER].
- 4 Press [◀][▶] to select [YES].

```
NOW EMPTY?   ◀▶
[YES] NO      ↵
```

- 5 Press [ENTER].

The display returns to the original screen.

#### If you select [NO] without discarding discharged fluid:

This also allows you to go back to the original screen. The [EMPTY DRAIN BOTTLE] message disappears temporarily. When a certain amount of discharged fluid has collected in the bottle, the message appears again.

#### IMPORTANT

When you remove the drain bottle, a few drops of discharged fluid may come out of the machine. Exercise caution to prevent this fluid from soiling your hands or the floor.

#### ⚠ CAUTION

**When the [EMPTY DRAIN BOTTLE] message appears on the screen, discard discharged fluid as early as possible.**

Repeatedly selecting [NO] without discarding the discharged fluid may cause it to spill out of the drain bottle, soiling your hands or the floor.

## Disposing of Discharged Fluid

The drain bottle collects discharged fluid. You can dispose of discharged fluid even if the message "EMPTY DRAIN BOTTLE" is not displayed on the screen. Dispose of discharged fluid before the drain bottle becomes full.

### Procedure

- 1 Press [MENU].
- 2 Press [v] several times to display the screen shown below.

```
MENU      ◀◀
SUB MENU  ▶
```

- 3 Press [▶] once, and then press [v] several times to display the screen shown below.

```
SUB MENU  ◀◀
MAINTENANCE ▶
```

- 4 Press [▶] once, and then press [v] several times to display the screen shown below.

```
MAINTENANCE ◀◀
DRAIN BOTTLE ◀
```

- 5 Press [ENTER].

- 6 When the screen shown below appears, remove the drain bottle and discard the discharged fluid.

```
EMPTY      ◀
DRAIN BOTTLE ◀
```

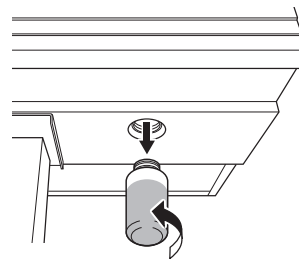
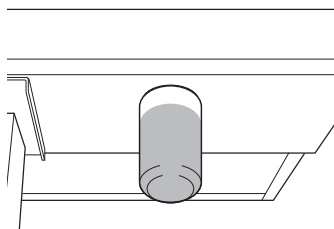

### IMPORTANT

When you remove the drain bottle, a few drops of discharged fluid may come out of the machine. Exercise caution to prevent this fluid from soiling your hands or the floor.

### ⚠ CAUTION

**Before you detach the drain bottle, be sure to wait for the screen to display [EMPTY DRAIN BOTTLE]. After discarding the discharged fluid, promptly attach the drain bottle to the machine.**

Failing to follow this procedure may cause discharged fluid to flow out of the machine and spill, soiling your hands or the floor.

**7** Quickly attach the emptied drain bottle to the machine once more.

**8** Press [ENTER].

```
EMPTY   ◀
DRAIN BOTTLE  ↵
```

**9** Press [ENTER].

```
RESET DRAIN
COUNTER ↵
```

**10** Press [MENU] to go back to the original screen.

### IMPORTANT

When you remove the drain bottle, a few drops of discharged fluid may come out of the machine. Exercise caution to prevent this fluid from soiling your hands or the floor.

#### WARNING

**Never place discharged fluid or ink near an open flame.**  
Doing so may cause a fire.

#### CAUTION

**To store discharged fluid temporarily, place it in the included drain bottle or in a durable sealed container such as a metal can or polyethylene tank, and cap the container tightly.**

Any spillage or vapor leakage may cause a fire, an odor, or physical distress.

### Dispose of discharged fluid properly, in accordance with the laws in effect in your locale.

Discharged fluid is flammable and contains toxic ingredients. Never attempt to incinerate discharged fluid or discard it with ordinary trash. Also, do not dispose of it in sewer systems, rivers, or streams. Doing so may have an adverse impact on the environment.

### If It Is Not Possible to Check the Amount of Discharged Fluid in the Drain Bottle

Sometimes, ink affixes to the inside of the drain bottle, which makes it difficult to check the amount of discharged fluid. In this situation, clean the inside of the drain bottle by using one of the following procedures.

#### Procedure A

Scrape the inside of the drain bottle clean using one of the included cleaning sticks.

Dispose of used cleaning sticks. They cannot be used for any other cleaning.

If this method is not effective, perform procedure B.

#### Procedure B (when procedure A is not effective)

**1** Remove the drain bottle, which you will clean, from the machine.

**2** Attach another drain bottle (included) to the machine.

**3** When discarding the liquid from the removed drain bottle, leave about 2 to 3 cm (0.8 to 1.2 inches) of discharged fluid in the bottom of the bottle.

- 4 **Securely cap the drain bottle.**
- 5 **Gently shake the drain bottle to wet the inside of the bottle with the discharged fluid.**  
Tilt the drain bottle to make the entirety of the inside of the bottle wet.
- 6 **Stand the bottle upright and leave it for 1 to 2 hours.**
- 7 **If the inside of the bottle is not cleaned sufficiently of ink stains, repeat steps 4 and 5.**
- 8 **Discard the discharged fluid.**

## Timing of Print Head Care and Maintenance

To keep a stable printing condition at all times, the print heads need to be maintained. There are maintenance tasks that should be performed daily and those that should be performed periodically.

Note: The print heads are components that wear out. Periodic replacement is required, with the frequency of replacement depending on use. Purchase them from your authorized Roland DG Corp. dealer.

---

### Daily Care and Maintenance

---

➤ **Printing tests and normal cleaning**

We recommend performing a printing test and normal cleaning before day-to-day operation.

☞ P. 54 "Step 5 : Printing Tests and Normal Cleaning"

---

### When Normal Cleaning Is Not Effective

---

➤ **Medium cleaning/powerful cleaning**

Perform medium cleaning or powerful cleaning when problems such as dot drop-out are not corrected after performing normal cleaning.

☞ P. 88 "When Normal Cleaning Is Not Effective"

---

### If the message "TIME FOR MAINTENANCE" is displayed

---

➤ **Manual cleaning**

Perform manual cleaning periodically according to your frequency of use.

☞ P. 90 "Manual Cleaning"

---

### When You Cannot Correct Dot Drop-out

---

➤ **Super cleaning**

Perform super cleaning when problems such as dot drop-out are not corrected after performing powerful and manual cleaning.

☞ P. 100 "Super Cleaning"

---

**Care and Maintenance When Uneven Color Occurs**

---

***When uneven colors occur while using white ink***

---

---

**➤ Mixing the ink by shaking the pouch tray**

Perform this procedure when printed colors are unstable or uneven, e.g., when color density is inconsistent, even if the same data is printed with the same settings.

☞ P. 97 "Mixing the Ink by Shaking the Pouch Tray"

**➤ Damper cleaning**

Perform this procedure if uneven color issues are not resolved even after shaking the pouch tray to mix the ink.

☞ P. 97 "Damper Cleaning (When Uneven Color Issues Occur with White Ink)"

**➤ Super cleaning**

Perform this procedure if uneven color issues are not resolved even after performing damper cleaning.

☞ P. 100 "Super Cleaning"

***When uneven colors occur while not using white ink***

---

---

**➤ Mixing the ink by shaking the pouch tray**

Perform this procedure when printed colors are unstable or uneven, e.g., when color density is inconsistent, even if the same data is printed with the same settings.

☞ P. 97 "Mixing the Ink by Shaking the Pouch Tray"

**➤ Super cleaning**

Perform this procedure if uneven color issues are not resolved even after shaking the pouch tray to mix the ink.

☞ P. 100 "Super Cleaning"

# When Normal Cleaning Is Not Effective

## Medium/Powerful Cleaning

### IMPORTANT

"Medium" and "powerful" cleaning consume more ink than "normal cleaning," and overly frequent use may damage the print heads themselves. Avoid using it more than necessary.

When problems such as dot drop-out are not resolved by normal cleaning (P. 54 "Step 5 : Printing Tests and Normal Cleaning"), perform the more forceful "medium cleaning" to remove clogging from the print heads. If this still does not resolve the problem, try the even more forceful "powerful cleaning."

### Procedure

3

Maintenance

#### 1 Perform a printing test.

☞ P. 54 "Step 5 : Printing Tests and Normal Cleaning"

When the printing test is finished, the screen shown below appears. Remove the media at this point.

```
CLEANING  ◀◆
TEST PRINT  ◀↓
```

#### 2 Press [FUNCTION].

#### 3 Press [▶] once, and then press [▼] several times to display the screen shown below.

When "Medium" is not effective, select "Powerful."

```
CLEANING  ◀◆  CLEANING  ◀◆
MEDIUM CL. ▶  POWERFUL CL. ▶
```

#### 4 Press [▶] to display the screen shown below.

```
MEDIUM CL. ◀◆▶  POWERFULL CL. ◀◆▶
  AB             ◀↓  AB             ◀↓
```

#### 5 Check for the group with dot drop-out by viewing the printing-test results.

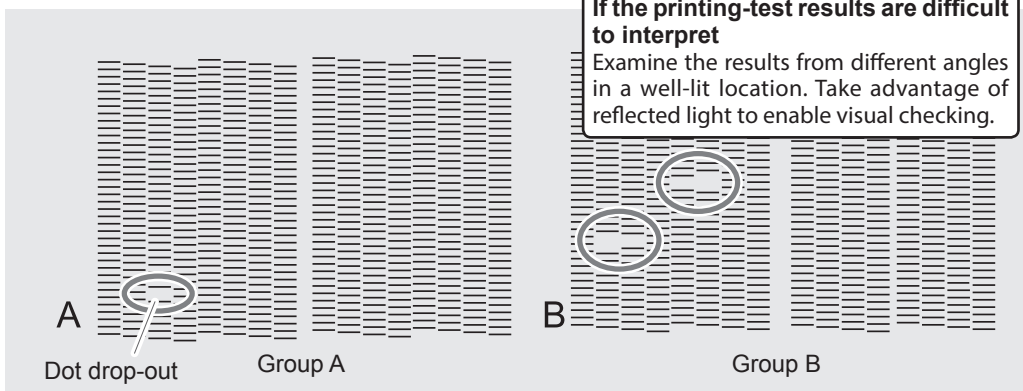

**6** Select the group of print heads to clean.

① Press [←] or [→] to select the group of print heads that is not to be cleaned.

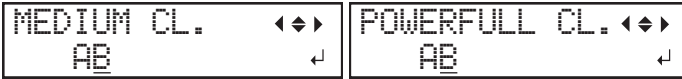

② Press [▲] or [▼] to get rid of the group display.

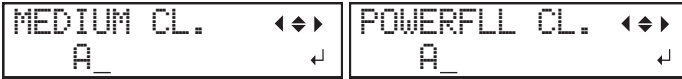

③ Repeat steps ① and ② to display only the group of print heads that requires cleaning. Only the displayed groups will be cleaned. If A and B are displayed, they will both be cleaned.

**7** Press [ENTER].

The screen shown in the following figure appears, and then cleaning starts. The (approximate) remaining time for the procedure is displayed on the screen. (The display shown below is an example. "01:45" = "1 minute and 45 seconds")



When finished, the screen shown below appears again.

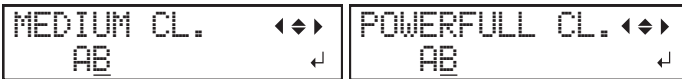

**8** Press [FUNCTION] to go back to the original screen.

**9** Perform a printing test again to make sure the dot drop-out has been corrected.

☞ P. 54 "Step 5 : Printing Tests and Normal Cleaning"

***When powerful cleaning is not effective.***

If problems such as dot drop-out persist even after you have performed powerful cleaning several times, perform "manual cleaning." Such cleaning can be effective when carried out periodically, according to the frequency of use.

☞ P. 90 "Manual Cleaning"

# Manual Cleaning

## Manual Cleaning

### If the message "TIME FOR MAINTENANCE" is displayed

When the above message is displayed, be sure to perform the manual cleaning.

### Manual Cleaning Is Recommended When The Following Symptoms Occur

It is recommended to perform manual cleaning when any of the symptoms given below occur and cannot be solved by automatic cleaning functions such as normal cleaning.

Replacing the wiper is also an effective means of improving the symptoms.

☞ P. 104 "Replacing the Wiper"

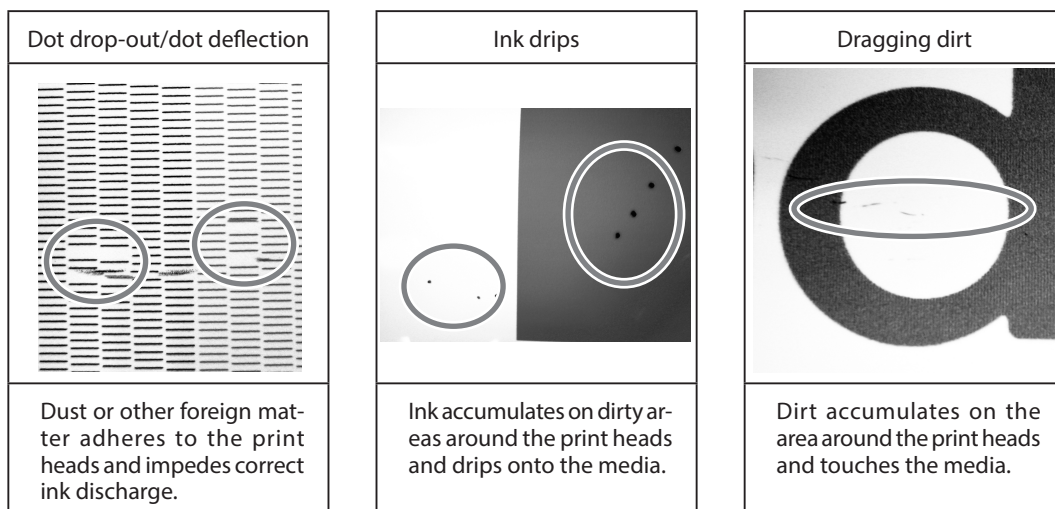

- If you use up the cleaning sticks and cleaning liquid used for manual cleaning, contact your authorized Roland DG Corp. dealer.
- The print heads are components that wear out. Periodic replacement is required, with the frequency of replacement depending on use. Contact your authorized Roland DG Corp. dealer.

### Important notes on this procedure



- Before attempting this operation, remove any media.
- To prevent the print heads from drying out, finish this procedure in 30 minutes or less. A warning beep sounds after 30 minutes.
- Never use any implements other than the included cleaning sticks. Cotton swabs or other lint-producing items may damage the print heads. If you use up the cleaning sticks, contact your authorized Roland DG Corp. dealer.
- Use one cleaning stick per cleaning session, and then discard the stick after use. Reusing cleaning sticks will adversely affect the printing results.
- Do not put a cleaning stick that has been used for cleaning into the cleaning liquid. Doing so will deteriorate the cleaning liquid.
- Never rub the print head surface (nozzle surface).
- Stroke the sponges very gently, applying as little pressure as possible. Never rub, scrape, or crush them.

**If a warning beep sounds during cleaning**

A warning beep sounds 30 minutes after operation starts. Temporarily stop work, and then close the left, right, and front covers. Press [ENTER] to end the manual cleaning mode. After that, restart the procedure from the beginning.

**⚠ CAUTION**

**Be sure to perform operations as specified by the instructions, and never touch any area not specified in the instructions.**  
Sudden movement of the machine may cause injury.

Required items	
 Cleaning stick	 Cleaning liquid

**1. Prepare for manual cleaning.**

- 1** Remove any media.
- 2** Press [FUNCTION].
- 3** Press [▶] once, and then press [▼] several times to display the screen shown below.

```
CLEANING  ◀▶
MANUAL CL.  ↵
```

- 4** Press [ENTER].
- 5** When the following screen is displayed, open the left cover.

```
OPEN COVER L
```

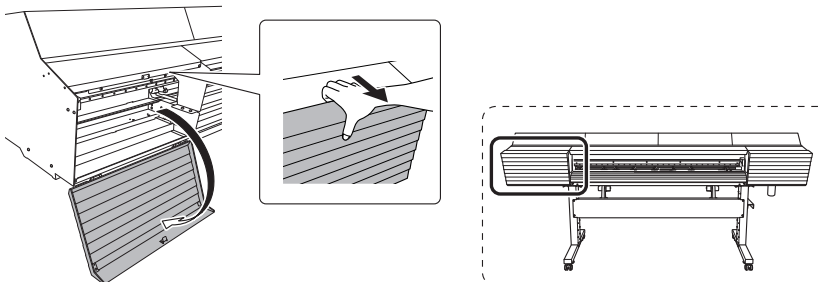

- 6 When the following screen is displayed, remove the cut rail.

REMOVE CUT  
RAIL ←

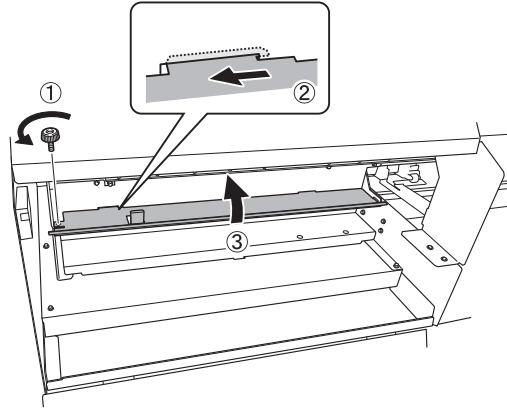

- 7 Press [ENTER].

- 8 When the following screen is displayed, close the left cover.

CLOSE COVER L

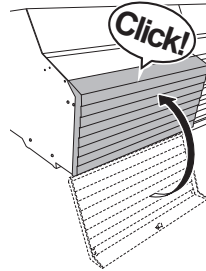

- 9 When the following screen is displayed, open the left cover.

OPEN COVER L

- 10 When the following screen is displayed, open the right cover.

OPEN COVER R

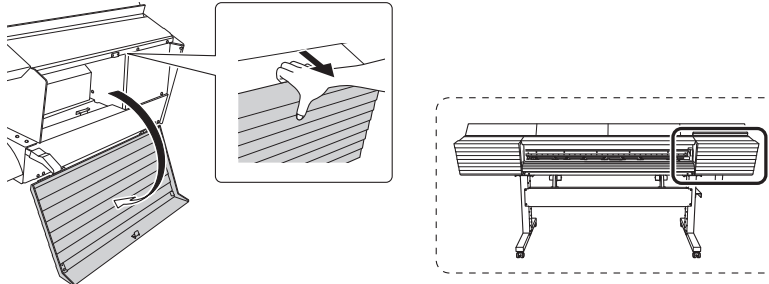

Preparation is complete once the following screen is displayed.

FINISHED?



3

Maintenance

2. Clean the wiper and the area around the print heads.

- 1 Touch the location shown in the figure to discharge any static electricity.

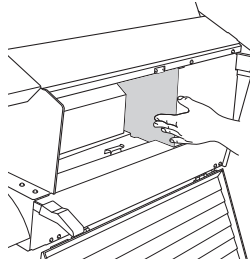

- 2 Moisten the cleaning stick with the cleaning liquid.

**IMPORTANT**

Be sure to perform cleaning using one of the included cleaning sticks.

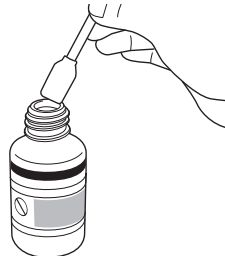

- 3 Clean the locations shown in the following figure.  
Be especially careful to clean away any fibrous dust (lint).

Area to clean

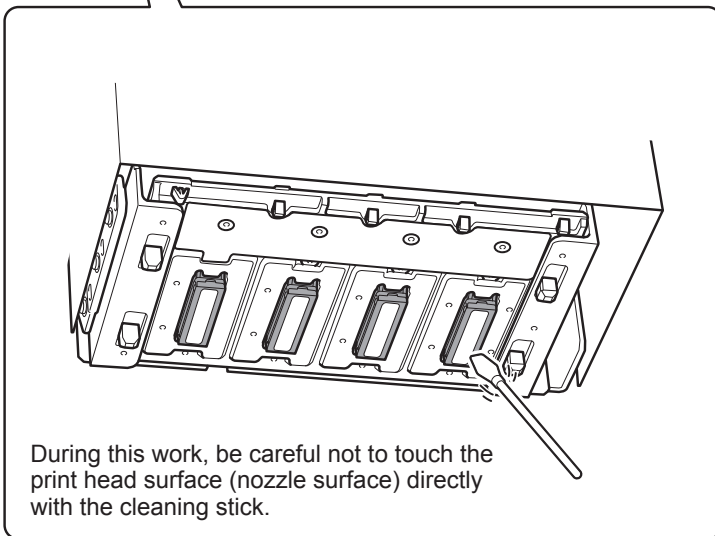
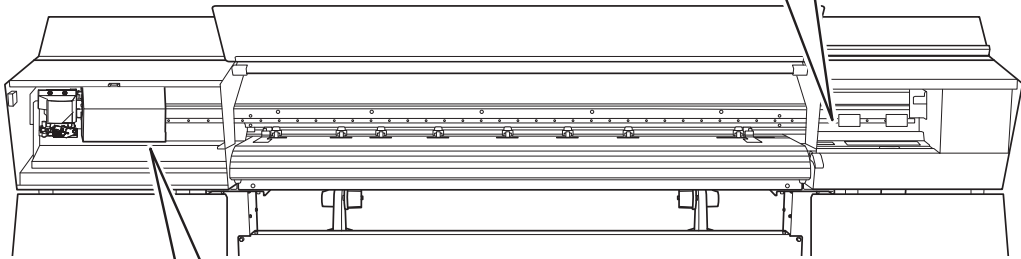
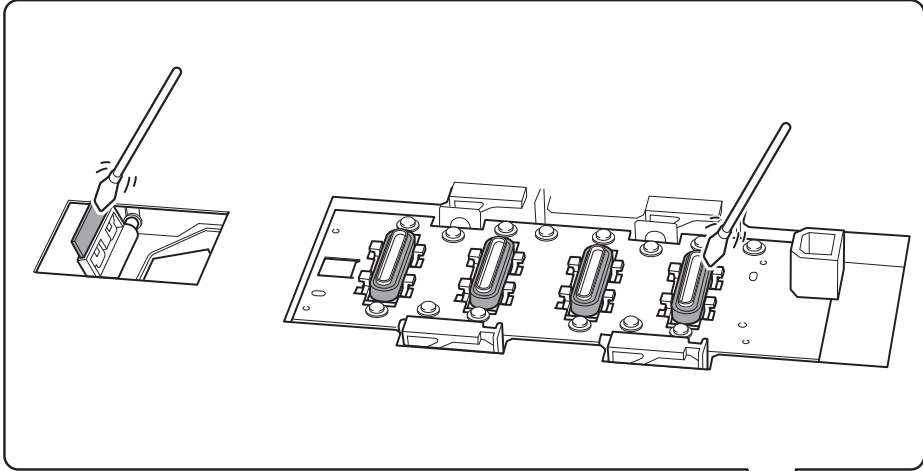

During this work, be careful not to touch the print head surface (nozzle surface) directly with the cleaning stick.

### 3. End the manual cleaning mode.

1 When cleaning is finished, press [ENTER].

2 When the following screen is displayed, close the right cover.

CLOSE COVER R

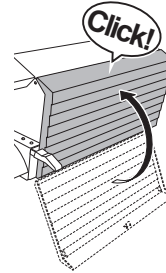

3 When the following screen is displayed, close the left cover.

CLOSE COVER L

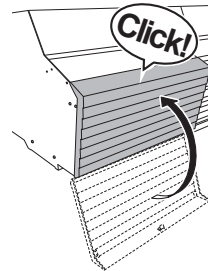

4 When the following screen is displayed, open the left cover.

OPEN COVER L

5 When the following screen is displayed, attach the cut rail.

REPLACE CUT  
RAIL ↵

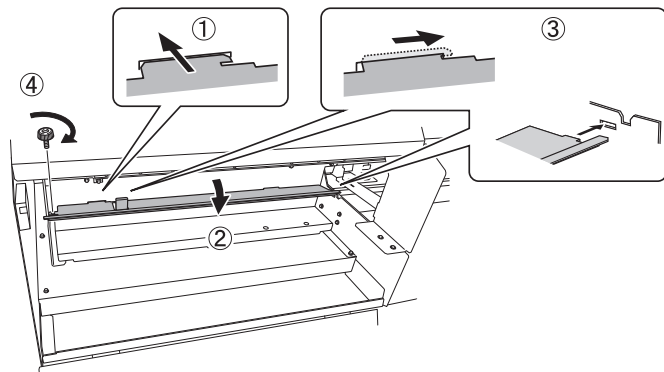

6 Press [ENTER].

7 When the following screen is displayed, close the left cover.



The screen shown below appears, and then cleaning starts. The (approximate) remaining time for the procedure is displayed on the screen. (The display shown below is an example. "01:45" = "1 minute and 45 seconds")



When cleaning finishes, the screen shown below appears again.



8 Press [FUNCTION] to go back to the original screen.

#### 4. Perform a printing test to check the results.

If necessary, perform normal cleaning multiple times.

☞ P. 54 "Step 5 : Printing Tests and Normal Cleaning"

# If Colors Are Uneven

## Mixing the Ink by Shaking the Pouch Tray

If ink components precipitate in the ink pouch, colors may be uneven (unevenness in printed colors). If colors are uneven, remove the pouch trays, and then shake them gently.

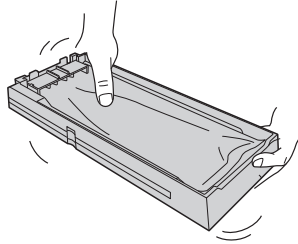

### IMPORTANT

- Do not remove the ink pouches. Shake the entire pouch tray. Removing the ink pouches may lead to the ink leaking.
- Before shaking an ink pouch, wipe off any ink from around the mouth of the ink pouch. If you do not wipe off the ink, it may splatter when you shake the pouch tray.
- When you have finished mixing the ink, reinsert the pouch tray immediately. If you take time to reinsert the ink tray, the ink trays will be adversely affected.

If uneven color issues with white ink are not resolved even after shaking the pouch trays to mix the ink, perform Damper Cleaning.

☞ P. 97 "Damper Cleaning (When Uneven Color Issues Occur with White Ink)"

If uneven color issues with ink other than white ink (LcLmLk ink or CMYK ink) are not resolved even after shaking the pouch trays to mix the ink, perform super cleaning.

☞ P. 100 "Super Cleaning"

## Damper Cleaning (When Uneven Color Issues Occur with White Ink)

If uneven color issues with white ink are not resolved even after shaking the pouch trays, perform "damper cleaning." Uneven colors refers to the symptom of printed colors being uneven (such as the color density being inconsistent) even when the same data is printed with the same settings.

Damper cleaning can be used to stabilize the printed colors by agitating the ink.

### IMPORTANT

- **Damper cleaning consumes a lot of ink, and overly frequent use may damage the print heads themselves. Avoid using this cleaning method more than necessary.**
  - **When you perform damper cleaning, replace the LcLmLkW ink with a new ink pouch. If the ink runs out during cleaning, a "CLEANING ERROR" will occur, and cleaning will stop..**
    - \* The ink pouch that you have removed can still be used in operations other than damper cleaning (such as printing).
- ☞ P. 202 "[CLEANING ERROR]"

Procedure

1 Press [MENU].

2 Press [▼] several times to display the screen shown below.

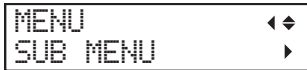

3 Press [▶] once, and then press [▼] several times to display the screen shown below.



4 Press [▶] once, and then press [▼] several times to display the screen shown below.



5 Press [▶].

The screen shown below appears. The ink slot whose LED is flashing is the target for ink replacement.



6 Replace the LcLmLkW ink with a new ink pouch.

☞ P. 71 "Ink Pouch Replacement"

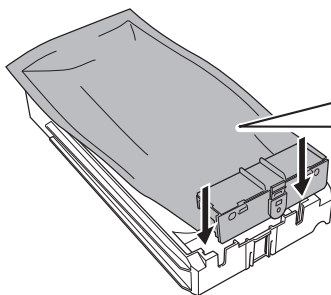

**IMPORTANT**

Replace the LcLmLkW ink with a new ink pouch.

7 Press [ENTER].

The screen shown in the following figure appears, and then cleaning starts. The (approximate) remaining time for the procedure is displayed on the screen. (The display shown below is an example. "01:45" = "1 minute and 45 seconds")

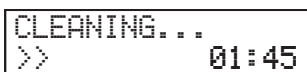

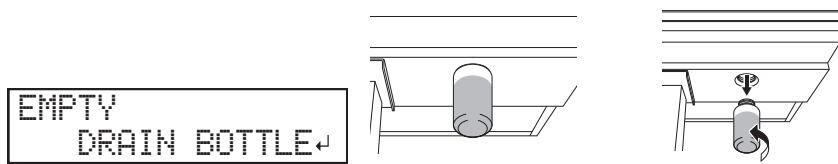
**When "EMPTY DRAIN BOTTLE" is displayed during cleaning**

- ① Remove the drain bottle and discard the discharged fluid.
- ② Quickly attach the emptied drain bottle to the machine once more.
- ③ Press [ENTER].

**IMPORTANT**

When you remove the drain bottle, a few drops of discharged fluid may come out of the machine. Exercise caution to prevent this fluid from soiling your hands or the floor.

**⚠ CAUTION**

**When [EMPTY DRAIN BOTTLE] is displayed on the screen, you must discard the discharged fluid**

Failing to discard the discharged fluid when [EMPTY DRAIN BOTTLE] is displayed will lead to the discharged fluid overflowing during cleaning.

**⚠ CAUTION**

**Before you detach the drain bottle, be sure to wait for the screen to display [EMPTY DRAIN BOTTLE]. After discarding the discharged fluid, promptly attach the drain bottle to the machine.**

Failing to follow this procedure may cause discharged fluid to flow out of the machine and spill, soiling your hands or the floor.

**⚠ WARNING**

**Never place discharged fluid or ink near an open flame.**

Doing so may cause a fire.

**⚠ CAUTION**

**To store discharged fluid temporarily, place it in the included drain bottle or in a durable sealed container such as a metal can or polyethylene tank, and cap the container tightly.**

Any spillage or vapor leakage may cause a fire, an odor, or physical distress.

**Dispose of discharged fluid properly, in accordance with the laws in effect in your locale.**

Discharged fluid is flammable and contains toxic ingredients. Never attempt to incinerate discharged fluid or discard it with ordinary trash. Also, do not dispose of fluid in sewer systems, rivers, or streams. Doing so may have an adverse impact on the environment.

When cleaning finishes, the screen shown below appears again.

**8 Press [MENU] to go back to the original screen.**

If uneven color issues with white ink are not resolved by "damper cleaning," perform "super cleaning."

☞ P. 100 "Super Cleaning"

# When Dot Drop-outs/Uneven Colors Are Not Fixed

## Super Cleaning

In the following cases, perform "super cleaning."

- If ink discharge issues such as dot drop-out are not corrected after performing cleaning using the cleaning function (normal, medium, powerful) or manual cleaning.
- If uneven color issues with white ink are not resolved even after performing damper cleaning.
  - ☞ P. 97 "Damper Cleaning (When Uneven Color Issues Occur with White Ink)"
- If uneven color issues with ink other than white ink (LcLmLk ink or CMYK ink) are not resolved even after shaking the pouch trays to mix the ink.
  - ☞ P. 97 "Mixing the Ink by Shaking the Pouch Tray"

### IMPORTANT

A large amount of ink will be discharged during super cleaning. Perform this operation only when dot drop-out or uneven colors cannot be corrected even after performing cleaning using the other cleaning functions (normal, medium, powerful, manual, and damper cleaning).

☞ P. 82 "Daily Maintenance", P. 88 "When Normal Cleaning Is Not Effective", P. 90 "Manual Cleaning"

## Procedure

### 1 Perform a printing test.

☞ P. 54 "Step 5 : Printing Tests and Normal Cleaning"

When the printing test is finished, the screen shown below appears. Remove the media at this point.

```
CLEANING  ◀◆
TEST PRINT  ↵
```

### 2 Press [MENU].

### 3 Press [▼] several times to display the screen shown below.

```
MENU  ◀◆
SUB MENU  ▶
```

### 4 Press [▶] once, and then press [▼] several times to display the screen shown below.

```
SUB MENU  ◀◆
INK CONTROL  ▶
```

### 5 When using eight colors (CMYKLcLmLkW) or seven colors (CMYKLcLmLk): Press [▶] then [▼] to display the screen shown below.

When using four colors (CMYK): Press [▶] to display the screen shown below.

```
INK CONTROL  ◀◆
SUPER CL.  ▶
```

### 6 Press [▶].

**7** Check for the group with dot drop-out by viewing the printing-test results.

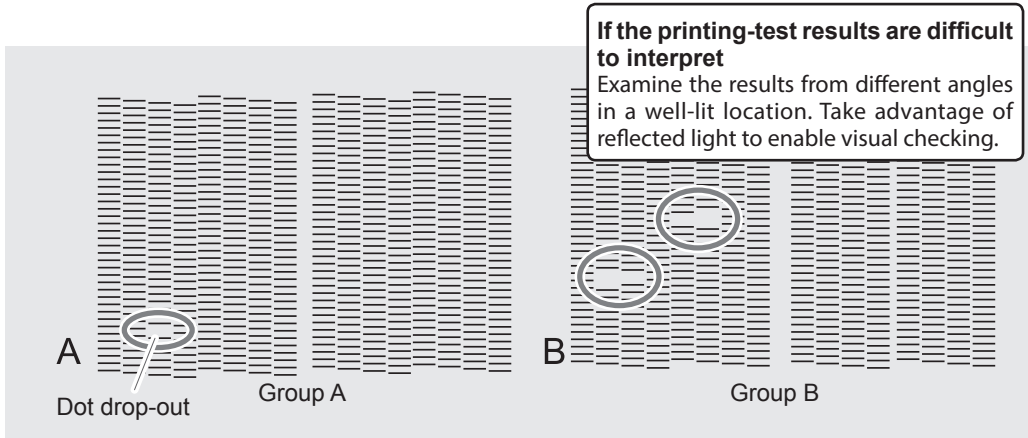

**8** Select the group of print heads to clean.

① Press [←] or [→] to select the group of print heads that is not to be cleaned.



② Press [▲] or [▼] to get rid of the group display.



③ Repeat steps ① and ② to display only the group of print heads that requires cleaning. Only the displayed groups will be cleaned. If A and B are displayed, they will both be cleaned.

**9** Press [ENTER].

**10** When the screen shown below appears, remove the drain bottle and discard the discharged fluid.

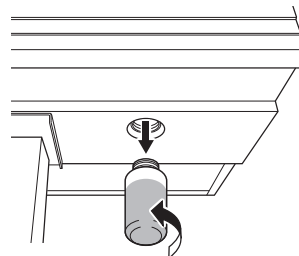
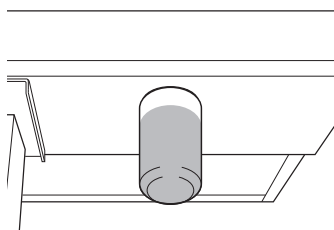

**IMPORTANT**

When you remove the drain bottle, a few drops of discharged fluid may come out of the machine. Exercise caution to prevent this fluid from soiling your hands or the floor.

**⚠ CAUTION**

Before you detach the drain bottle, be sure to wait for the screen to display [EMPTY DRAIN BOTTLE]. After discarding the discharged fluid, promptly attach the drain bottle to the machine.

Failing to follow this procedure may cause discharged fluid to flow out of the machine and spill, soiling your hands or the floor.

**11** Quickly attach the emptied drain bottle to the machine once more.

**12** Press [ENTER].



**⚠ WARNING**

Never place discharged fluid or ink near an open flame. Doing so may cause a fire.

**⚠ CAUTION**

To store discharged fluid temporarily, place it in the included drain bottle or in a durable sealed container such as a metal can or polyethylene tank, and cap the container tightly.

Any spillage or vapor leakage may cause a fire, an odor, or physical distress.

**Dispose of discharged fluid properly, in accordance with the laws in effect in your locale.**

Discharged fluid is flammable and contains toxic ingredients. Never attempt to incinerate discharged fluid or discard it with ordinary trash. Also, do not dispose of it in sewer systems, rivers, or streams. Doing so may have an adverse impact on the environment.

The screen shown in the following figure appears, and then cleaning starts. The (approximate) remaining time for the procedure is displayed on the screen. (The display shown below is an example. "01:45" = "1 minute and 45 seconds")

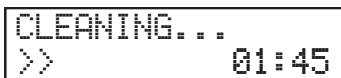

When finished, the screen shown below appears again.



**13** Press [MENU] to go back to the original screen.

**14** Perform a printing test again to make sure the dot drop-out has been corrected.

☞ P. 54 "Step 5 : Printing Tests and Normal Cleaning"

## Cleaning of the Surface of the Print Heads as an Emergency Measure

When dot drop-out or dot deflection is not improved even if cleaning is performed several times, you can clean the surface of the print heads as an emergency measure. The print head surface (nozzle surface) is a very delicate mechanism, so work must be performed carefully and cautiously.

Note that this operation is an emergency measure. Depending on symptoms, it may damage normal areas and cause symptoms to worsen. If you have any questions, contact your authorized Roland DG Corp. dealer.

### Procedure

- 1 Soak up a generous amount of cleaning liquid using a cleaning stick.**
- 2 Very gently touch the cleaning stick against the print head surface (nozzle surface).**  
Very softly press the cleaning stick against the print head so that cleaning liquid soaks into the print head surface (nozzle surface). Never rub the stick or press it forcefully against the print head surface.

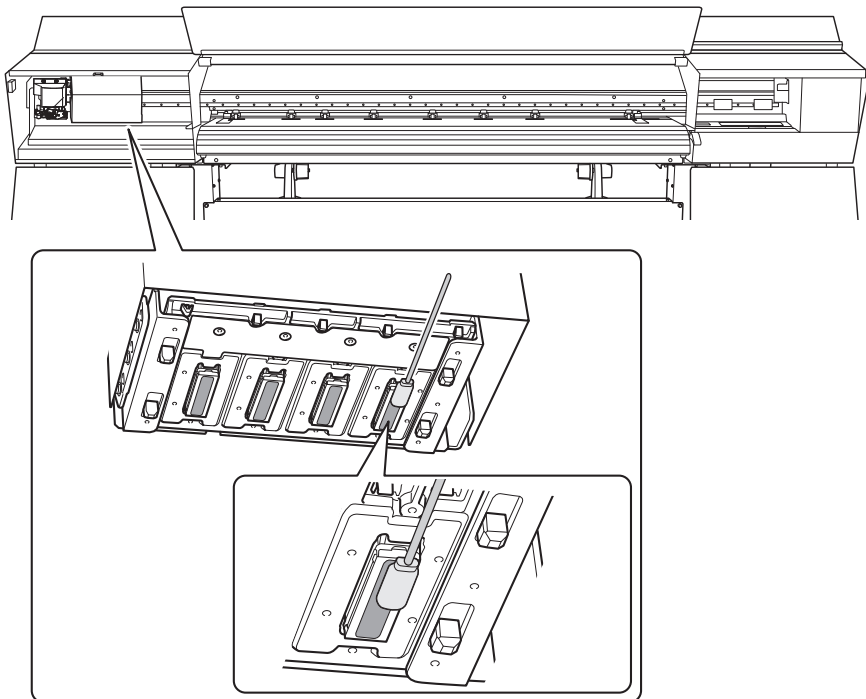

# Replacing Consumable Parts

## Replacing the Wiper

The wiper is a component that is used when cleaning the print heads. When the following screen is displayed, it is time to replace the wiper.

For information about purchasing wipers, contact your authorized Roland DG Corp. dealer.

```
TIME FOR  
WIPER REPLACE ↵
```

### ⚠ CAUTION

Be sure to perform operations as specified by the instructions, and never touch any area not specified in the instructions.

Sudden movement of the machine may cause injury.

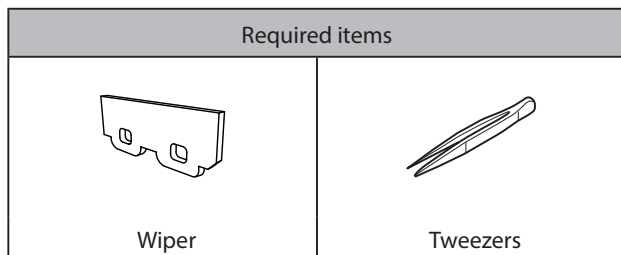

### 1. Enter the wiper replacement menu.

- 1 Press [ENTER] when the following screen appears.

```
TIME FOR  
WIPER REPLACE ↵
```

- 2 Remove any media.

- 3 Press [MENU].

- 4 Press [▼] several times to display the screen shown below.

```
MENU                    ◀◆  
SUB MENU               ▶
```

- 5 Press [▶] once, and then press [▼] several times to display the screen shown below.

```
SUB MENU               ◀◆  
MAINTENANCE           ▶
```

- 6 Press [▶] to display the screen shown below.

```
MAINTENANCE           ◀◆  
REPLACE WIPER        ↵
```

**7 Press [ENTER].**

The cutting carriage moves to a location where wiper replacement is possible, and then the screen shown below appears.

OPEN COVER R

**2. Replace the wiper.**

**1 Open the right cover.**

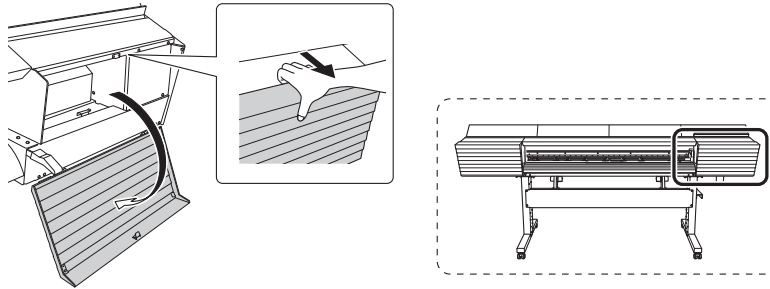

Preparation is complete once the following screen is displayed.

FINISHED?



**2 Touch the location shown in the figure to discharge any static electricity.**

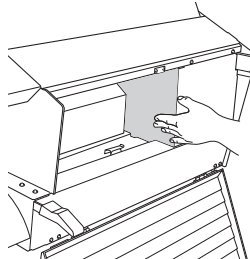

**3** Replace the wiper.

Detaching old wiper

Detach the hook  
Hitching the tweezers to the hole on the wiper makes the removal easier.

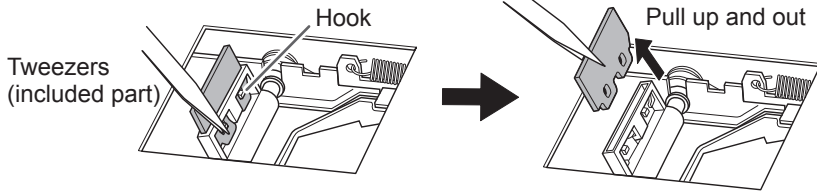

Attaching new wiper

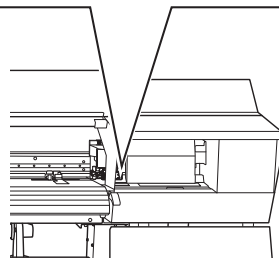
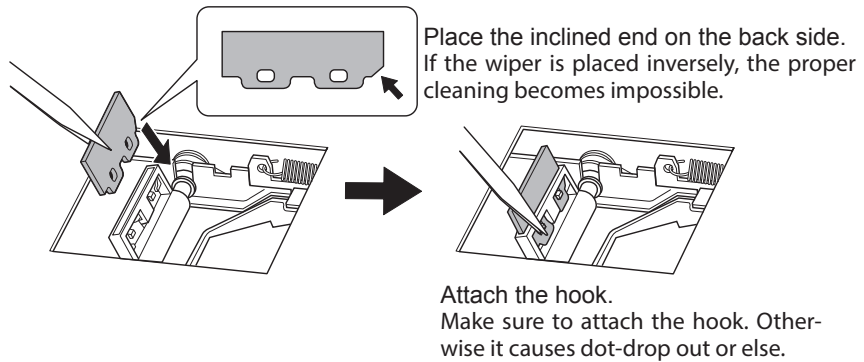

**4** Press [ENTER].

- 5 When the following screen is displayed, close the right cover.

CLOSE COVER R

When the following screen is displayed again, the wiper replacement is finished.

MAINTENANCE ◀◆  
REPLACE WIPER ▶

- 6 Press [MENU] to go back to the original screen.

- 7 Perform normal cleaning.

☞ P. 54 "Step 5 : Printing Tests and Normal Cleaning"

## Cleaning the Wiper Tray and Replacing the Tray Pads

Discharged fluid collects in the wiper tray. When the following message appears, it is time to clean the wiper tray. Clean the wiper tray, and then replace the tray pads.

TIME FOR  
TRAY CLEANING▶

### ⚠ CAUTION

Be sure to perform operations as specified by the instructions, and never touch any area not specified in the instructions. Sudden movement of the machine may cause injury.

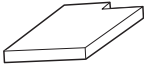
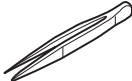
Required items	
 Tray pads (3)	 Tweezes

1. Enter the wiper tray cleaning menu.

- 1 Press [ENTER].

TIME FOR  
TRAY CLEANING▶

- 2 Press [MENU].

- 3 Press [v] several times to display the screen shown below.

MENU ◀◆  
SUB MENU ▶

- 4 Press [▶] once, and then press [▼] several times to display the screen shown below.



- 5 Press [▶] once, and then press [▼] several times to display the screen shown below.



- 6 Press [ENTER].

## 2. Discard the discharged fluid.

- 1 When the message shown below appears, detach the bottle, discard the discharged fluid to empty it.

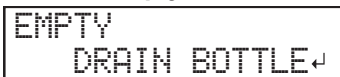

### IMPORTANT

When you remove the drain bottle, a few drops of discharged fluid may come out of the machine. Exercise caution to prevent this fluid from soiling your hands or the floor.

**⚠ CAUTION** Before you detach the drain bottle, be sure to wait for the screen to display "EMPTY DRAIN BOTTLE." After discarding the discharged fluid, promptly attach the drain bottle to the machine.

Failing to follow this procedure may cause discharged fluid to flow out of the tube and spill, soiling your hands or the floor.

**⚠ WARNING** Never place discharged fluid or ink near an open flame. Doing so may cause a fire.

**⚠ CAUTION** To store discharged fluid temporarily, place it in the included drain bottle or in a durable sealed container such as a metal can or polyethylene tank, and cap the container tightly.

Any spillage or vapor leakage may cause a fire, an odor, or physical distress.

**Dispose of discharged fluid properly, in accordance with the laws in effect in your locale.**

Discharged fluid is flammable and contains toxic ingredients. Never attempt to incinerate discharged fluid or discard it with ordinary trash. Also, do not dispose of it in sewer systems, rivers, or streams. Doing so may have an adverse impact on the environment.

- 2 Quickly attach the emptied drain bottle to the machine once more.

- 3 Press [ENTER].

3. Clean the wiper tray, and then replace the tray pad.

- 1 When the following screen is displayed, open the right cover.

OPEN COVER R

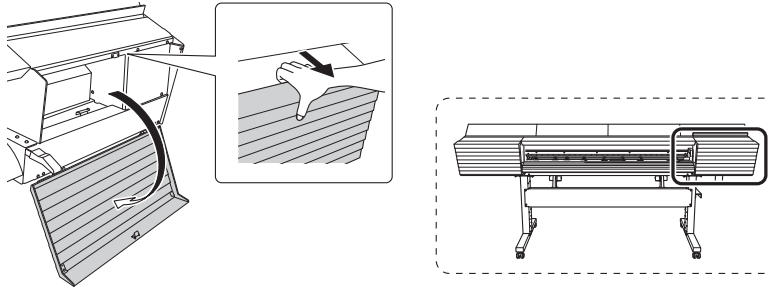

- 2 When the following screen is displayed, open the waste valve.

OPEN  
WASTE VALVE

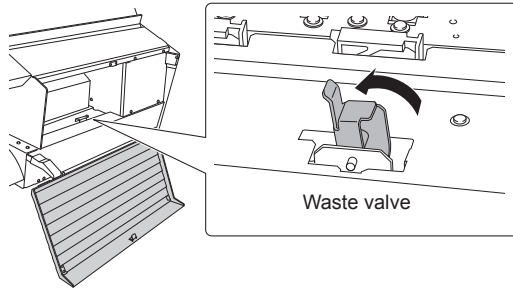

- 3 When the following screen is displayed, close the right cover.

CLOSE COVER R

- 4 When the following screen is displayed, open the right cover.

OPEN COVER R

- 5 When the following screen is displayed, close the waste valve.

CLOSE  
WASTE VALVE

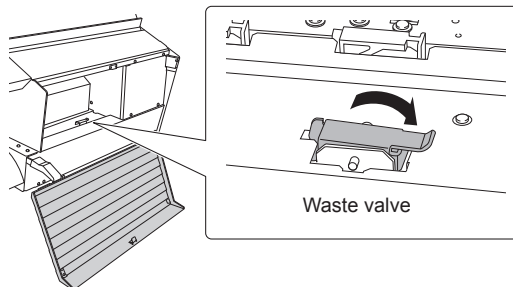

- 6** When the following screen is displayed, replace the tray pad.  
There are three tray pads. Replace all three tray pads.

**IMPORTANT**

Place the tray pad with an orientation that matches the shape of the wiper tray. If you place the tray pad with the incorrect orientation, it will not be possible to clean the wiper correctly.

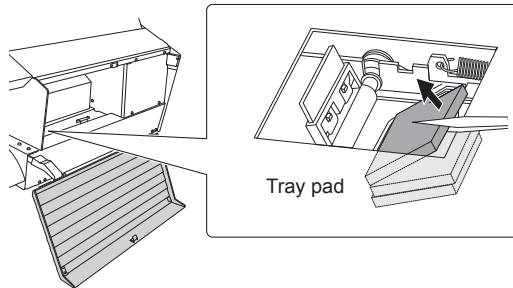

- 7** Press [ENTER].
- 8** When the following screen is displayed, close the right cover.



The screen shown below appears, and then the machine is filled with TR cleaning liquid. The (approximate) remaining time for the procedure is displayed on the screen. (The display shown below is an example. "01:40" = "1 minute and 40 seconds")

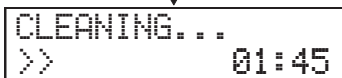

If the TR cleaning liquid runs out during filling, the screen shown below appears. Replace the TR cleaning liquid pouch. When you replace the TR cleaning liquid pouch, the display returns to the original screen.

☞ P. 73 "TR Cleaning Liquid Pouch Replacement"



\* "CL-LIQUID FOR WIPER" represents the TR cleaning liquid.

When the following screen is displayed again, the wiper tray cleaning is finished.



- 9** Press [MENU] to go back to the original screen.

## Replacing the Blade

If the blade becomes dull, or if the edge of the blade is chipped, or if the blade quality is lowered, replace it with a new blade.

**⚠ CAUTION**

**Be sure to perform operations as specified by the following instructions, and never touch any area not specified in the instructions.**

Sudden movement of the machine may cause injury.

**⚠ CAUTION**

**Never touch the tip of the knife.**

Doing so may result in injury.

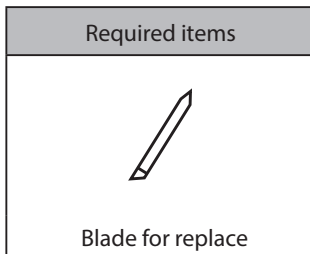

### 1. Enter the "REPLACE KNIFE" menu.

1 Remove any media.

2 Press [MENU].

3 Press [▼] several times to display the screen shown below.



4 Press [▶] once, and then press [▼] several times to display the screen shown below.



5 Press [▶] once, and then press [▼] several times to display the screen shown below.



6 Press [ENTER].

The cutting carriage moves to a position where blade replacement is possible.

- 7 When the following screen is displayed, open the front cover.

OPEN FRONT  
COVER

Preparation is complete once the following screen is displayed.

FINISHED? ↵

## 2. Replace the blade.

- 1 Remove the blade holder.

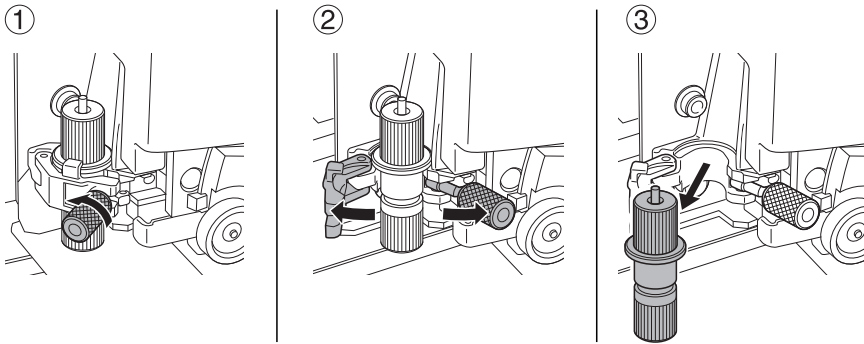

- 2 Replace the blade.

- 1 Press the pin to push out the old blade.  
2 Insert a new blade.

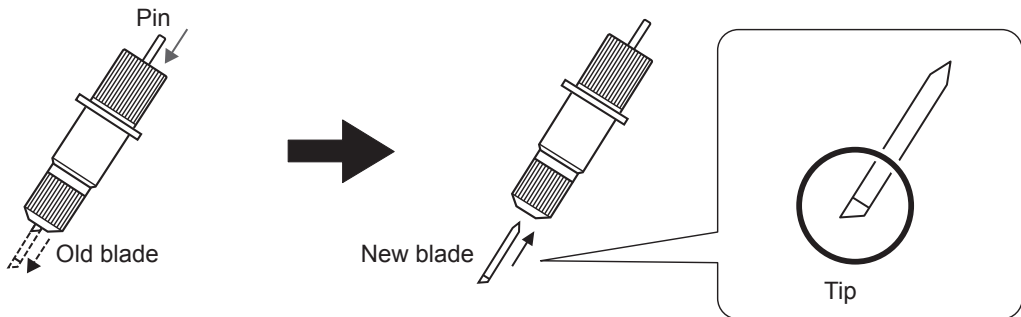

**3** Install the cutting tool in the cutting carriage.

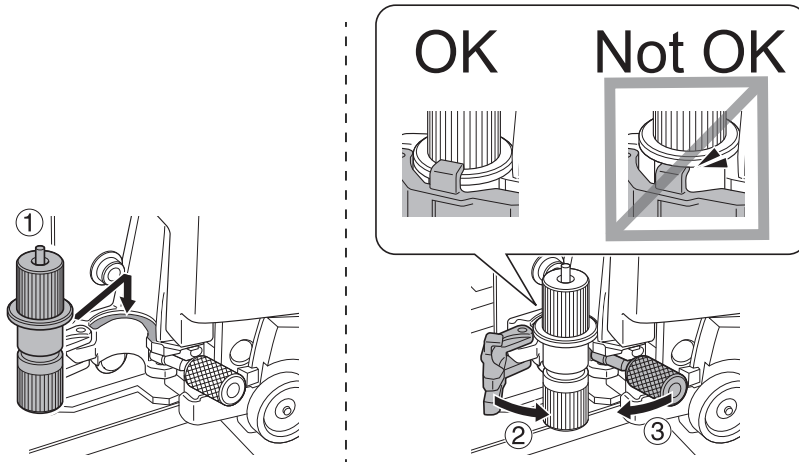

**4** Tighten the screw.

Tug the blade holder upward to make sure it does not come loose.

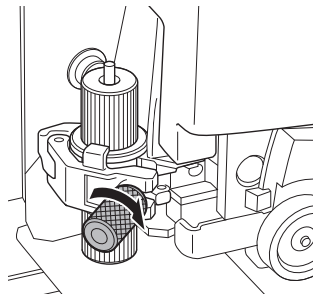

**3.** Quit the "REPLACE KNIFE" menu.

**1** Close the front cover.

**2** Press [ENTER].

When the following screen is displayed again, the blade replacement is finished.



**3** Press [MENU] to go back to the original screen.

**4.** Adjusting the cutting conditions and cutting-in amount.

☞ P. 143 "Fine-tuning the Cutting Conditions", P. 145 "Accurately Adjusting the Cutting-in Amount"

## Replacing the Separating Knife

If the separating knife becomes dull, replace it with the included replacement knife.

**⚠ CAUTION** **Be sure to perform operations as specified by the instructions, and never touch any area not specified in the instructions.**  
Sudden movement of the machine may cause injury.

**⚠ CAUTION** **Never touch the tip of the knife.**  
Doing so may result in injury.

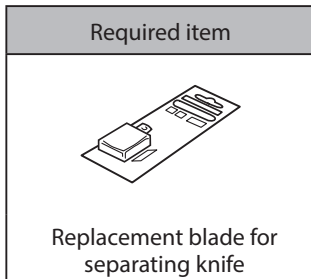

3

Maintenance

### 1. Enter the "REPLACE KNIFE" menu.

- 1 Remove any media.
- 2 Press [MENU].
- 3 Press [▼] several times to display the screen shown below.

```
MENU      ◀◆
SUB MENU  ▶
```

- 4 Press [▶] once, and then press [▼] several times to display the screen shown below.

```
SUB MENU  ◀◆
MAINTENANCE ▶
```

- 5 Press [▶] once, and then press [▼] several times to display the screen shown below.

```
MAINTENANCE ◀◆
REPLACE KNIFE ↓
```

- 6 Press [ENTER].  
The cutting carriage moves to a position where blade replacement is possible.

- 7** When the following screen is displayed, open the front cover.

OPEN FRONT  
COVER

Preparation is complete once the following screen is displayed.

FINISHED? ↵

## 2. Replace the separating knife.

- 1** Remove the separating knife.

**1** Loosen the screw until it slips out.

**2** Grasp the screw portion, and then slowly pull it out in the direction of the arrow.

When doing this, do not pull it back toward you.

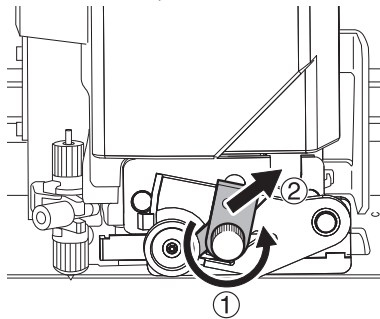

- 2** Install a new knife.

The knife is secured in place by the magnet.

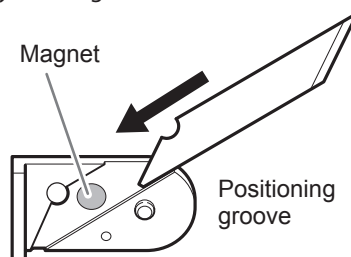

- 3** Slowly insert it into the groove.

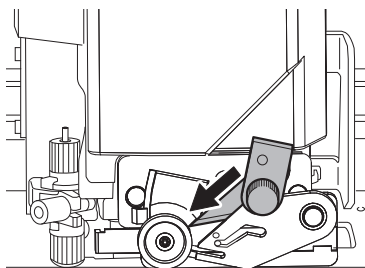

### 4 Tighten the screw.

Take care to ensure that the knife does not slip out of position at this time.

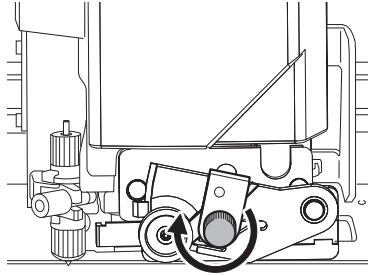

## 3. Exit the blade replacement menu.

### 1 Close the front cover.

### 2 Press [ENTER].

When the following screen is displayed again, the blade replacement is finished.

```
MAINTENANCE  ◀▶
REPLACE KNIFE  ↓
```

### 3 Press [MENU] to go back to the original screen.

# When Not in Use for a Prolonged Period

## Keep Performing Maintenance

### Switch on the power once a month

Switch on the sub power once a month. When you turn on the power, the machine automatically performs operations such as those to keep the print heads from drying out. Leaving the machine unused for a prolonged period may damage the print heads, so be sure to switch on the power to perform these automatic operations.

☞ P. 24 "Power Supply Operations"

### Keep at a constant temperature and relative humidity

Even when the machine is not in use, keep it at a temperature of 5 to 40°C (41 to 104°F) and a relative humidity of 20 to 80% (with no condensation). Temperatures that are too high may degrade the ink and cause malfunction. Temperatures that are too low may cause the ink to freeze and damage the print heads.

## Disposing of Discharged Fluid

If you know that you will not use the machine for a prolonged period, empty the drain bottle.

When the main power is on, the machine periodically performs automatic maintenance in which fluid is discharged.

- Approximately 80 days after the drain bottle is emptied
- Approximately 2 weeks after the message "EMPTY DRAIN BOTTLE" is displayed

The drain bottle is filled when the above periods have elapsed. Leaving the drain bottle as-is will lead to the discharged fluid overflowing.

☞ P. 83 "When "EMPTY DRAIN BOTTLE" Is Displayed"



# Chapter 4 Advanced Functions

Using Presets.....	120
Saving the Current Settings (Preset Saving).....	120
Loading a Saved Preset .....	122
Settings for the Media Heating System.....	123
What Is the Media Heating System? .....	123
Making the Temperature Setting for the Media Heating System .....	124
Setting the Temperature during Preheating .....	125
Drying the Trailing Edge of the Printing Area on the Dryer.....	126
Setting the Drying Time after Printing (When Only Printing) .....	127
Setting the Drying Time after Printing (When Printing and Cutting) .....	128
Using an Optional Dryer .....	129
Using a Blower-fan Unit.....	130
Correction Functions.....	131
Correcting for Misalignment in Bidirectional Printing .....	131
Correcting for Misalignment in Bidirectional Printing More Precisely .....	132
Reducing Horizontal Bands (Feed Correction Function).....	133
Configuring Settings to Match the Properties of the Media.....	135
Adjusting Print Head Height to Match Media Thickness.....	135
Using Transparent Media .....	136
Using Hard-to-Dry Media.....	137
Using Media That Wrinkles Easily/Does Not Move Smoothly .....	138
Speeding Up Output for Narrow Media .....	139
Preventing Soiling of the Media and Dot Drop-out .....	140
Using Sticky Media .....	141
Advanced Cutting Settings.....	142
Fine-tuning the Cutting Conditions .....	142
Accurately Adjusting the Cutting-in Amount.....	144
Performing Distance Correction During Cutting .....	145
Correcting the Misalignment of the Printing and Cutting Positions.....	146
Prioritizing the Cutting Settings of This Machine over the Software RIP Settings.....	148
Viewing the Automatic Environment Correction Function Settings.....	149
Correcting the Misalignment of the Printing and Cutting Positions during Cutting .....	150
Advanced Settings for Printing and Cutting with Crop Marks .....	152
Aligning Positions Manually .....	152
Correcting Misalignment for Printing and Cutting When Using Crop Marks.....	154
Using the Media Take-up Unit.....	157
About the Media Take-Up Unit.....	157
Performing Operations from Roland DG Mobile Panel.....	158
What Is Roland DG Mobile Panel?.....	158
Downloading Mobile Panel.....	158
Using Mobile Panel.....	159
Important Notes on Using Mobile Panel .....	159
Other Useful Functions .....	161
Using the Print Light (Interior Light).....	161
Performing Printing Tests Arranged Horizontally .....	161
Using Media Flanges for Paper Tubes (Cores) with an Internal Diameter of 2 Inches.....	162

# Using Presets

## Saving the Current Settings (Preset Saving)

### Procedure

1 Press [MENU].

2 Press [▼] to display the screen shown below.

```
MENU      ◀◆▶
PRESET    ▶
```

3 Press [▶], then [▼] to display the screen shown below.

```
PRESET    ◀◆▶
SAVE      ▶
```

4 Press [▶] to display the screen shown below.

```
SAVE      ◀◆▶
NAME1    ◀↵
```

5 Decide on the preset number.

① Press [▲] or [▼] to select one option from "NAME1" to "NAME8."

② Press [ENTER] to confirm your entry.

The current menu settings are saved, and then the screen shown below appears.

```
SET NAME  ◆▶
S         ◀↵
```

6 Set the preset name.

① Press [▲] or [▼] to select a character.

② When you have selected the character you want to enter, press [▶].

The characters you can enter are "A" through "Z," "0" through "9," and the "-" character.

③ Press [▲] or [▼] to select the next character.

Select the following characters in the same way. You can enter up to 15 characters, including spaces.

```
SET NAME  ◆◆▶
SAMPLE    ◀↵
```

④ When you have finished, press [ENTER] to confirm your entry.

7 Press [MENU] to go back to the original screen.

## Description

Using the [PRESET] menu lets you easily change a wide variety of settings to optimize them for the media. Up to eight types of presets can be saved. You can assign a name to each one. Using media names for these may aid recognition and clarity. Making changes for each menu item every time you change the media can be troublesome. That's why it can be useful to save the menu-item settings optimized for an often-used type of media as a preset. The next time you use the media, you can change the menu-item settings to the optimal values for the media simply by loading the preset you saved. The menu items that can be saved in presets are listed below.

Menu item	Reference page
[PRINT] (print heater), [DRYER]	P. 124 "Making the Temperature Setting for the Media Heating System"
[PREHEATING]	P. 125 "Setting the Temperature during Preheating"
[FEED FOR DRY]	P. 126 "Drying the Trailing Edge of the Printing Area on the Dryer"
[DRYING TIME]	P. 127 "Setting the Drying Time after Printing (When Only Printing)"
[DRY TIME P&C]	P. 128 "Setting the Drying Time after Printing (When Printing and Cutting)"
[ADJUST BI-DIR SIMPLE SETTING]	P. 131 "Correcting for Misalignment in Bidirectional Printing"
[ADJUST BI-DIR DETAIL SETTING]	P. 132 "Correcting for Misalignment in Bidirectional Printing More Precisely"
[CALIBRATION]	P. 133 "Reducing Horizontal Bands (Feed Correction Function)"
[EDGE DETECTION]	P. 136 "Using Transparent Media"
[SCAN INTERVAL]	P. 137 "Using Hard-to-Dry Media"
[VACUUM POWER]	P. 138 "Using Media That Wrinkles Easily/Does Not Move Smoothly"
[FULL WIDTH S]	P. 139 "Speeding Up Output for Narrow Media"
[MEDIA RELEASE]	P. 141 "Using Sticky Media"
[FORCE], [SPEED], [OFFSET], [UP-SPEED]	P. 142 "Fine-tuning the Cutting Conditions"
[CALIBRATION] (in the [CUTTING MENU])	P. 145 "Performing Distance Correction During Cutting"
[PRINT-CUT ADJ.]	P. 146 "Correcting the Misalignment of the Printing and Cutting Positions"
[CROP-CUT ADJ.]	P. 154 "Correcting Misalignment for Printing and Cutting When Using Crop Marks"

## Loading a Saved Preset

### Procedure

- 1 Press [MENU].
- 2 Press [▼] to display the screen shown below.



A rectangular screen with a black border. The top line displays 'MENU' and the bottom line displays 'PRESET'. To the right of 'MENU' is a left-pointing arrow and a right-pointing arrow. To the right of 'PRESET' is a right-pointing arrow.

- 3 Press [▶] twice to display the screen shown below.

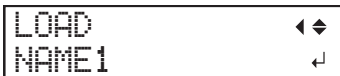

A rectangular screen with a black border. The top line displays 'LOAD' and the bottom line displays 'NAME1'. To the right of 'LOAD' is a left-pointing arrow and a right-pointing arrow. To the right of 'NAME1' is a left-pointing arrow and a right-pointing arrow.

- 4 Select the preset that you want to load.
  - 1 Press [▲] or [▼] to select the name of the preset you want to load.
  - 2 Press [ENTER] to confirm your entry.

- 5 Press [MENU] to go back to the original screen.

### Description

This loads a saved preset from among the eight types of presets. If you load a preset while [SETUP] is lit, [SETUP] flashes. After that, when the setup operation is complete, [SETUP] returns to being lit.

# Settings for the Media Heating System

## What Is the Media Heating System?

This machine is equipped with a media heating system that warms the media. You use this mainly to improve ink adhesion and dry the ink. You can adjust the temperature settings to match the type of media and the printing speed.

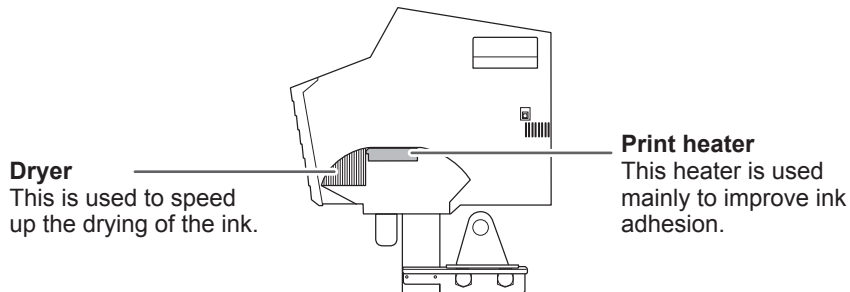

Note: By using an optional dryer, you can speed up the drying of the ink more. For recommended drying unit models, contact your authorized Roland DG Corporation dealer.

☞ P. 129 "Using an Optional Dryer"

### **⚠ WARNING**

#### **Caution: High temperatures**

The platen and dryer become hot. Exercise caution to avoid fire or burns.

### **⚠ WARNING**

#### **When output is not being performed, remove any loaded media or switch off the sub power.**

The continued application of heat at a single location may cause fire or produce toxic gases.

### **⚠ WARNING**

#### **Never use media that cannot withstand the heat.**

Doing so may result in fire or the release of toxic gases or may degrade the media.

### **⚠ WARNING**

#### **Never use the platen or dryer for any purpose for which they are not intended, such as to dry clothing.**

Doing so may cause overheating, resulting in fire or accident.

**Use the machine in an environment with an ambient temperature of 20 to 32°C (68 to 90°F).**

If the machine is used at an ambient temperature lower than 20°C (68°F), then depending on the type or width of the media, wrinkling or temperature-caused unevenness may occur. If this happens, try lowering the temperature of the media heating system by about 2°C (36°F). To obtain stable printing results, however, use the machine in an environment with an ambient temperature of 20 to 32°C (68 to 90°F).

## Making the Temperature Setting for the Media Heating System

### Procedure

- 1 Press [FUNCTION].
- 2 Press [▼] several times to display the screen shown below.

```
FUNCTION      ◀◆
HEATER CONFIG ▶
```

- 3 Press [▶] to display the screen shown below.

```
HEATER CONFIG ◀◆
PRINT        40° C ▶
```

- 4 Press [▲] or [▼] to select "PRINT" (print heater) or "DRYER."

```
HEATER CONFIG ◀◆  HEATER CONFIG ◀◆
PRINT        40° C ▶  DRYER        40° C ▶
```

- 5 Press [▶] to display the screen shown below.

```
PRINT        40° C ▶ 40° C ◀  DRYER        50° C ▶ 50° C ◀
```

- 6 Press [▲] or [▼] to select the temperature.

You can also set the temperature to "OFF." When set to "OFF," the media heating system does not operate at all.

#### PRINT (print heater): General Guide for Setting the Temperature

```
PRINT        40° C ▶ 45° C ◀
```

Use this mainly to improve ink adhesion and inhibit smudging. If the ink forms lumps or smudges, raise the temperature. Note, however, that a temperature that is too high may degrade the media or cause it to wrinkle.

#### DRYER: General Guide for Setting the Temperature

```
DRYER        50° C ▶ 45° C ◀
```

When ink drying is poor, raise the temperature. Note, however, that a temperature that is too high may degrade the media or cause it to wrinkle.

- 7 Press [ENTER] to confirm your entry.
- 8 Press [FUNCTION] to go back to the original screen.

## Description

With the default settings, simply switching on the power does not make the dryer warm up to the set temperature. The temperature rises to the set temperature when the media is loaded correctly and [SETUP] lights. You can also make this setting in the software RIP. When you have made the setting in the software RIP, the software RIP's setting is used.

Note: Depending on the usage environment, the temperature of the print heater or dryer may become higher than the set temperature, but this does not represent a problem.

### Hints and Tips for Setting the Temperature

#### Relationship between the print mode and temperature

The optimal temperature for the media heating system varies according to such factors as the type of media and differences in the print mode. If smudging or poor drying occur even after raising the temperature, try using a print mode of the software RIP offering higher image quality. Conversely, if you want to use a faster print mode, raise the temperature.

#### Amount of ink

When you change the amount of ink using the settings for your software RIP, adjusting this may yield better results. If problems such as smudging persist even after raising the temperature, try reducing the amount of ink.

#### Other points to remember

When recommended settings for temperature, print mode, and other values are given as the use condition of your media, use the suggested settings.

## Setting the Temperature during Preheating

Note: Preheating: State in which the main power and the sub power are switched on and [SETUP] is not lit (state in which the media setup is not completed)

### Procedure

- 1 Press [MENU].
- 2 Press [▼] several times to display the screen shown below.

```
MENU          ◀◀
HEATER MENU   ▶
```

- 3 Press [▶], then [▼] to display the screen shown below.

```
HEATER MENU   ◀◀
PREHEATING    ▶
```

- 4 Press [▶] to display the screen shown below.

```
PREHEATING    ◀◀
30°C          ▶ 30°C  ↵
```

- 5 Press [▲] or [▼] to select a setting.
  - MENU: The system performs heating to the set temperature at all times, without lowering the temperature during preheating.
  - 30°C: The system maintains a temperature of 30°C (86°F) during preheating.
  - OFF: The system switches the media heating system off during preheating.

```

PREHEATING  ◀◆
30°C  ▶ MENU  ⏏
    
```

- 6 Press [ENTER] to confirm your entry.
- 7 Press [MENU] to go back to the original screen.

---

### Default Settings

---

[PREHEATING]: 30°C

## Drying the Trailing Edge of the Printing Area on the Dryer

### Procedure

---

- 1 Press [MENU].
- 2 Press [▼] several times to display the screen shown below.

```

MENU  ◀◆
HEATER MENU  ▶
    
```

- 3 Press [▶] to display the screen shown below.

```

FEED FOR DRY  ◀◆
DISABLE ▶DISABLE  ⏏
    
```

- 4 Press [▲] or [▼] to select "ENABLE" or "P&C."

```

FEED FOR DRY  ◀◆
DISABLE ▶ENABLE  ⏏
    
```

- 5 Press [ENTER] to confirm your entry.
- 6 Press [MENU] to go back to the original screen.

---

**Description**

---

**ENABLE:** Media feed is performed until the trailing edge of the printing area is positioned on the dryer. The margin between the print-end position and the next print-start position is set to a value of 100 mm (3.9 in.) when [OPTION DRYER] is set to "DISABLE" in the output data for printing only and 280 mm (11.1 in.) when it is set to "ENABLE." In the case of output data designed for printing and cutting, the margin is determined by the value specified with the data.

☞ P. 129 "Using an Optional Dryer"

**DISABLE:** Media feed stops when printing ends. This means that the trailing edge of the printing area is not fed to the dryer unless you continue with a subsequent printing operation.

**P&C:** Specify this setting if you want to enable only the output data designed for printing and cutting. The operation is the same as "ENABLE."

---

**Default Settings**

---

[FEED FOR DRY]: DISABLE

## Setting the Drying Time after Printing (When Only Printing)

To set the drying time for output data designed for printing and cutting, see the following section.

☞ P. 128 "Setting the Drying Time after Printing (When Printing and Cutting)"

**Procedure**

---

**1** Press [MENU].

**2** Press [▼] several times to display the screen shown below.

```
MENU      ◀◀
HEATER MENU ▶
```

**3** Press [▶] once, and then press [▲] twice to display the screen shown below.

```
HEATER MENU ◀◀
DRYING TIME ▶
```

**4** Press [▶] to display the screen shown below.

```
DRYING TIME ◀◀
 0min ▶ 0min↵
```

**5** Press [▲] or [▼] to select the drying time.

```
DRYING TIME ◀◀
 0min ▶ 10min↵
```

- 6 Press [ENTER] to confirm your entry.
- 7 Press [MENU] to go back to the original screen.

---

### Description

---

Set the drying time after the 1st page is printed. The next operation is not started until the set time passes. During drying, [PAUSE] is lit. Press [PAUSE] while [PAUSE] is lit to finish the drying time and start the next operation. Also, hold down [PAUSE] while [PAUSE] is lit to cancel the output. When the drying time has been set in the software RIP, priority is given to the software RIP's setting.

\* This setting is ignored for output data designed for printing and cutting.

---

### Default Settings

---

[DRYING TIME]: 0 min

## Setting the Drying Time after Printing (When Printing and Cutting)

To set the drying time for output data designed only for printing, see the following section.

⇨ P. 127 "Setting the Drying Time after Printing (When Only Printing)"

### Procedure

---

- 1 Press [MENU].
- 2 Press [▼] several times to display the screen shown below.

```
MENU      ◀▶
HEATER MENU ▶
```

- 3 Press [▶], then [▲] to display the screen shown below.

```
HEATER MENU ◀▶
DRY TIME P&C ▶
```

- 4 Press [▶] to display the screen shown below.

```
DRY TIME P&C ◀▶
  0min ▶  0min ↵
```

- 5 Press [▲] or [▼] to select the drying time.

```
DRY TIME P&C ◀▶
  0min ▶ 10min ↵
```

- 6 Press [ENTER] to confirm your entry.
- 7 Press [MENU] to go back to the original screen.

---

**Description**

---

Set the drying time after the 1st page is printed. The next operation is not started until the set time passes. During drying, [PAUSE] is lit. Press [PAUSE] while [PAUSE] is lit to finish the drying time and start the next operation. Also, hold down [PAUSE] while [PAUSE] is lit to cancel the output. When you have configured this setting, we recommend setting the [FEED FOR DRY] menu to "ENABLE" or "P&C." (P. 126 "Drying the Trailing Edge of the Printing Area on the Dryer")

This setting is also applied during printing and cutting with crop marks. Even if the drying time has been set in the included software RIP, priority is given to the setting on this machine.

\*This setting is ignored for output data designed only for printing.

---

**Default Settings**

---

[DRY TIME P&C]: 0 min

## Using an Optional Dryer

### Procedure

---

1 Press [MENU].

2 Press [▼] several times to display the screen shown below.

```
MENU      ◀▶
HEATER MENU ▶
```

3 Press [▶] once, and then press [▼] several times to display the screen shown below.

```
HEATER MENU ◀▶
OPTION DRYER ▶
```

4 Press [▶] to display the screen shown below.

```
OPTION DRYER ◀▶
DISABLE ▶DISABLE ↵
```

5 Press [▲] or [▼] to select "ENABLE."

```
OPTION DRYER ◀▶
DISABLE ▶ENABLE ↵
```

6 Press [ENTER] to confirm your entry.

7 Press [MENU] to go back to the original screen.

---

### Description

This switches the setting for the auxiliary drying unit between "ENABLE" and "DISABLE." When using an auxiliary drying unit, set [OPTION DRYER] to "ENABLE." This speeds up the drying of the ink. For recommended drying unit models, contact your authorized Roland DG Corporation dealer. For details on how to use the optional dryer, refer to the documentation of the dryer you are using.

---

### Default Settings

[OPTION DRYER]: DISABLE

## Using a Blower-fan Unit

### Procedure

- 1 Press [MENU].
- 2 Press [▼] several times to display the screen shown below.
 

```
MENU          ◀◀▶▶
HEATER MENU   ▶
```
- 3 Press [▶] once, and then press [▼] several times to display the screen shown below.
 

```
HEATER MENU   ◀◀▶▶
BLOWER FAN    ▶
```
- 4 Press [▶] to display the screen shown below.
 

```
BLOWER FAN    ◀◀▶▶
DISABLE ▶DISABLE ◀
```
- 5 Press [▲] or [▼] to select "ENABLE."
 

```
BLOWER FAN    ◀◀▶▶
DISABLE ▶ENABLE ◀
```
- 6 Press [ENTER] to confirm your entry.
- 7 Press [MENU] to go back to the original screen.

---

### Description

This switches the setting for the optional blower-fan unit between "ENABLE" and "DISABLE." When using a blower-fan unit, select "ENABLE." This speeds up the drying of the ink. For recommended blower-fan unit models, contact your authorized Roland DG Corporation dealer. For details on how to use the blower-fan unit, refer to the documentation of the blower-fan unit you are using.

---

### Default Settings

[BLOWER FAN]: DISABLE

# Correction Functions

## Correcting for Misalignment in Bidirectional Printing

1. Print the adjustment pattern for bidirectional printing.

① Press [MENU].

② Press [▼] several times to display the screen shown below.

```
MENU ◀◆
ADJUST BI-DIR ▶
```

③ Press [▶] to display the screen shown below.

```
ADJUST BI-DIR ◀◆
TEST PRINT ◀↵
```

④ Press [ENTER].

A test pattern is printed.

2. Set the correction value.

① When printing is finished, press [▼] to display the screen shown below.

```
ADJUST BI-DIR. ◀◆
SIMPLE SETTING ▶
```

② Press [▶] to display the screen shown below.

```
SIMPLE SETTING ◀◆
  0 ▶      0 ◀↵
```

**3 View the printed test pattern, and then determine the correction value.**

Select the value that gives the least misalignment between the two lines. In the case of the following figure, select "+5." When you cannot choose between two sequential numbers, select a value that is between them (you can set correction values in units of "0.5").

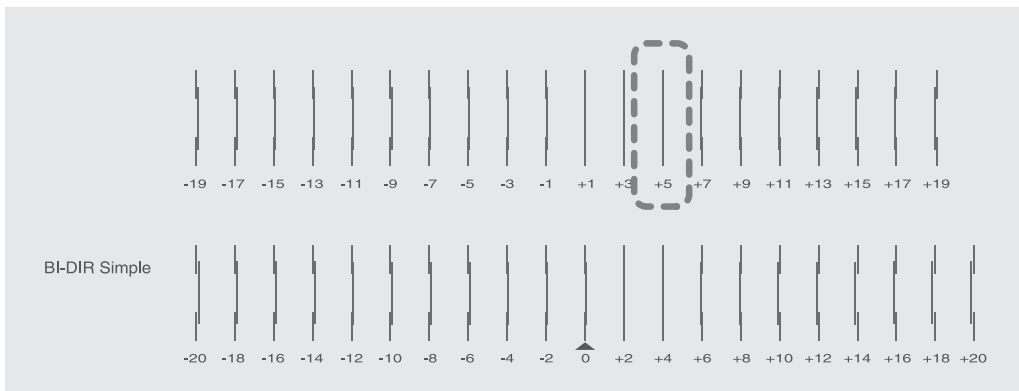

**4 Press [▲] or [▼] to set the correction value.**



**5 Press [ENTER] to confirm your entry.**

**6 Repeat step 1 to check whether the correction was successful.**

Check that the misalignment is minimized for the two vertical lines indicated by "▲" (that is, the current correction value). If the misalignment is smaller for another set of vertical lines, set the correction value again.

**7 When you have successfully performed the correction, press [MENU] to go back to the original screen.**

**Description**

This machine performs bidirectional printing (in which the heads perform printing during both their outbound pass and return pass). This method offers the advantage of being able to shorten output times, but subtle misalignment occurs during the outbound and return passes, which makes "bidirectional correction" necessary. This misalignment varies according to the print head height and the thickness of the media, so we recommend performing correction to match the media you are using.

**Correcting for Misalignment in Bidirectional Printing More Precisely**

When further correction is required, such as when adjustment made using [SIMPLE SETTING] does not enhance printing, use [DETAIL SETTING] to make corrections.

For instructions on how to perform the work, refer to P. 37 "Step 2 : Initial Adjustment (Correcting for Misalignment in Bidirectional Printing)".

## Reducing Horizontal Bands (Feed Correction Function)

### 1. Print the adjustment pattern for feed correction.

- 1 If using roll media, check that the media is not sagging.
- 2 Press [MENU].
- 3 Press [▼] several times to display the screen shown below.

```
MENU      ◀◀
CALIBRATION ▶
```

- 4 Press [▶] to display the screen shown below.

```
CALIBRATION ◀◀
TEST PRINT  ↵
```

- 5 Press [ENTER].  
A test pattern is printed.

### 2. Set the correction value.

- 1 When printing is finished, press [▼] to display the screen shown below.

```
CALIBRATION ◀◀
SETTING      ▶
```

- 2 Press [▶] to display the screen shown below.

```
SETTING      ◀◀
0.00% ▶ 0.00% ↵
```

**3 View the printed test pattern, and then determine the correction value.**

Select the value to make the gap and overlap between the upper/lower squares smallest. In the case of the following figure, select "-0.40." When you cannot choose between two sequential numbers, specify a value that is between them.

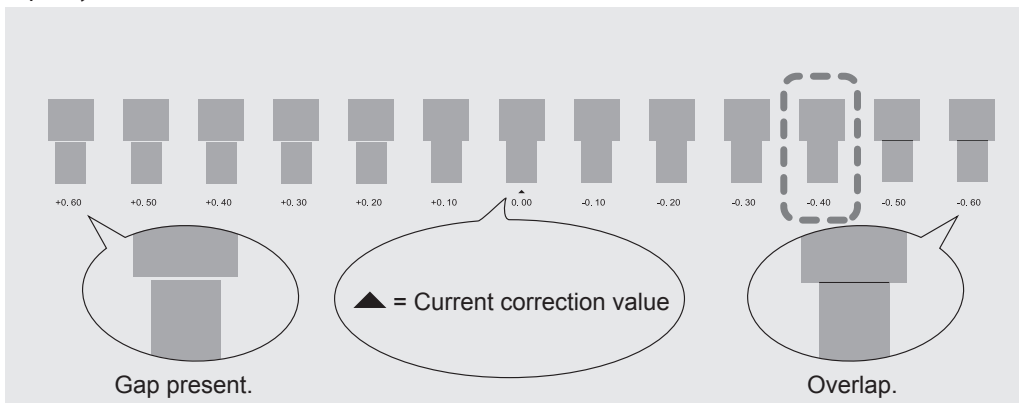

**4 Press [▲] or [▼] to select the correction value.**



**5 Press [ENTER] to confirm your entry.**

**6 Repeat step 1 to check whether the correction was successful.**

Check that the gap and overlap are the smallest for the figure indicated by "▲" (that is, the current correction value). If the gap and overlap are smaller for another figure, set the correction value again.

**7 When you have successfully performed the correction, press [MENU] to go back to the original screen.**

**Description**

The movement distance of the media changes subtly depending on the media's thickness and the temperature of the dryer. When the movement distance becomes discrepant, horizontal stripes are more likely to occur during printing. We recommend that you make corrections to match the media you are using and the set temperature of the dryer. Repeat the process of printing a test pattern and entering a correction value several times to find the optimal value.

Depending on the software RIP you are using, you can also configure this setting in the software RIP (by, for example, choosing the media type). When you have made the setting in the software RIP, the software RIP's setting is used and the printer's setting is ignored.

# Configuring Settings to Match the Properties of the Media

## Adjusting Print Head Height to Match Media Thickness

### Procedure

- 1 Press [MENU].
- 2 Press [▼] several times to display the screen shown below.

```
MENU      ◀◀
HEAD HEIGHT ▶
```

- 3 Press [▶] to display the screen shown below.

```
HEAD HEIGHT ◀
HIGH ▶ LOW ◀
```

- 4 Open the front cover.

- 5 Move the height-adjustment lever to adjust the head height.

When you change the position of the height-adjustment lever, the display screen will change. When the lever is moved to the "High" direction, the buzzer sounds twice. When it is moved to the "Low" direction, the buzzer sounds once.

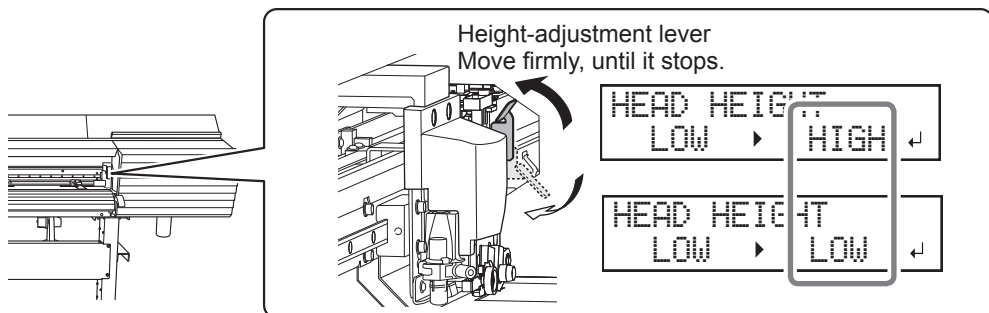

### MEMO

Normally move the height-adjustment lever to "Low." For media that is wrinkled or comes loose from the platen, move the height-adjustment lever to "High."

- 6 Press [ENTER] to confirm your entry.
- 7 Close the front cover.  
If the [PRESS THE ENTER KEY TO CONTINUE] message appears on the screen, press [ENTER].
- 8 Press [MENU] to go back to the original screen.

---

### Description

---

Depending on the media, media may wrinkle or come loose from the platen during printing, increasing the chance of contact with the print heads. When you are using such media, adjust [HEAD HEIGHT] to "HIGH." Printing quality when [HEAD HEIGHT] is set to "HIGH" may be coarser or otherwise lower than when set to "LOW." If this happens, refer to the pages indicated below.

☞ P. 131 "Correcting for Misalignment in Bidirectional Printing", P. 140 "Preventing Soiling of the Media and Dot Drop-out"

## Using Transparent Media

### Procedure

---

- 1 Press [MENU].
- 2 Press [▼] several times to display the screen shown below.

```
MENU      ◀◀
SUB MENU  ▶
```

- 3 Press [▶] to display the screen shown below.

```
SUB MENU  ◀◀
EDGE DETECTION ▶
```

- 4 Press [▶] to display the screen shown below.

```
EDGE DETECTION ◀◀
ENABLE ▶ENABLE ↵
```

- 5 Press [▲] or [▼] to select "DISABLE."

```
EDGE DETECTION ◀◀
ENABLE ▶DISABLE ↵
```

- 6 Press [ENTER] to confirm your entry.
- 7 Press [MENU] to go back to the original screen.

---

### Description

---

This setting enables or disables detection of the leading and trailing edges of the media. It is normally set to "ENABLE." When transparent media is loaded, set it to "DISABLE."

When [EDGE DETECTION] is set to "DISABLE," printing operation does not stop when the media runs out. If media runs out while printing is in progress, immediately press [PAUSE] to stop printing. Otherwise, there is a chance that the platen or other parts may become soiled by ink or that ink may get inside and damage the machine.

---

### Default Settings

---

[EDGE DETECTION]: ENABLE

## Using Hard-to-Dry Media

### Procedure

- 1 Press [MENU].
- 2 Press [▼] several times to display the screen shown below.

```
MENU      ◀◀
SUB MENU  ▶
```

- 3 Press [▶], then [▼] to display the screen shown below.

```
SUB MENU  ◀◀
SCAN INTERVAL ▶
```

- 4 Press [▶] to display the screen shown below.

```
SCAN INTERVAL ◀◀
OFF ▶ OFF ↵
```

- 5 Press [▲] or [▼] to select a value.

Larger values cause the media to move more slowly, enabling you to extend the drying time accordingly.

```
SCAN INTERVAL ◀◀
OFF ▶ 1.0sec ↵
```

- 6 Press [ENTER] to confirm your entry.
- 7 Press [MENU] to go back to the original screen.

### Description

Use this if ink dries poorly even when the dryer is used. Depending on the software RIP you are using, you can also make this setting in the software RIP. When you have made the setting in the software RIP, the printer's setting is ignored.

### Default Settings

[SCAN INTERVAL]: OFF

## Using Media That Wrinkles Easily/Does Not Move Smoothly

### Procedure

- 1 Press [MENU].
- 2 Press [▼] several times to display the screen shown below.

```
MENU      ◀◆
SUB MENU  ▶
```

- 3 Press [▶] once, and then press [▼] several times to display the screen shown below.

```
SUB MENU  ◀◆
VACUUM POWER ▶
```

- 4 Press [▶] to display the screen shown below.

```
VACUUM POWER ◀◆
  AUTO ▶   AUTO ↵
```

- 5 Press [▲] or [▼] to select a value.

0 to 100%	When the media is flimsy and cannot move smoothly, decreasing this value (reducing the suction force) may correct the problem.
AUTO	The suction force is automatically adjusted to the optimal level for the media width

```
VACUUM POWER ◀◆
  AUTO ▶   90% ↵
```

- 6 Press [ENTER] to confirm your entry.
- 7 Press [MENU] to go back to the original screen.

### Description

The platen uses suction to grip the media and keep it stable. The suction force can be adjusted corresponding to the nature and condition of the media. Depending on the software RIP you are using, you can also make this setting in the software RIP. When you have made the setting in the software RIP, the machine's setting is ignored.

### Default Settings

[VACUUM POWER]: AUTO

## Speeding Up Output for Narrow Media

### Procedure

- 1 Press [MENU].
- 2 Press [▼] several times to display the screen shown below.

```
MENU      ◀◀
SUB MENU  ▶
```

- 3 Press [▶] once, and then press [▼] several times to display the screen shown below.

```
SUB MENU  ◀◀
FULL WIDTH S ▶
```

- 4 Press [▶] to display the screen shown below.

```
FULL WIDTH S ◀◀
FULL ▶ FULL  ↵
```

- 5 Press [▲] or [▼] to select a setting.

```
FULL WIDTH S ◀◀
FULL ▶ OFF   ↵
```

<b>SHEET</b>	"SHEET" matches the range of print head movement to the width of the media.
<b>OFF</b>	OFF matches the range of print heads movement to the output data. Movement is limited to the minimum amount necessary, and this can be expected to yield the fastest output. Note, however, that because the speed of media movement is no longer constant, colors may be uneven.
<b>FULL</b>	"FULL" makes the speed of media movement constant at all times and produces the most stable printing result.

- 6 Press [ENTER] to confirm your entry.
- 7 Press [MENU] to go back to the original screen.

### Description

This shortens output time by reducing the width of head movement to the minimum necessary. This is effective when the width of the media or the output data is narrow.

### Default Settings

[FULL WIDTH S]: FULL

## Preventing Soiling of the Media and Dot Drop-out

### Procedure

- 1 Press [MENU].
- 2 Press [▼] several times to display the screen shown below.

```
MENU      ◀◆
SUB MENU  ▶
```

- 3 Press [▶] once, and then press [▼] several times to display the screen shown below.

```
SUB MENU  ◀◆
PERIODIC CL. ▶
```

- 4 Press [▶] to display the screen shown below.

The current setting is displayed on the screen.

```
PERIODIC CL. ◀◆
NONE          ↵
```

- 5 Press [▲] or [▼] to select a setting.

NONE	Automatic cleaning is not performed.
Page	Automatic cleaning is performed each time prior to the start of printing.
INTERVAL (JOB)	Automatic cleaning is performed when the cumulative printing time reaches the value you set here. However, if this time is reached during printing, automatic cleaning is performed before the next printing operation starts. Because printing is not paused, uneven color issues due to paused operation do not occur.
INTERVAL (TIME)	Automatic cleaning is performed when the cumulative printing time reaches the value you set here. When this time is reached during printing, printing pauses and so colors may be uneven.

- 6 Press [ENTER] to confirm your entry.
- 7 Press [MENU] to go back to the original screen.

### Description

In the following cases, ink tends to collect on the surface of the print heads. Under some conditions, this ink may be transferred to the media or cause dot drop-out.

- When you use media prone to static electricity buildup.
- When the ambient temperature is low.
- When the print-head height is set to "HIGH."

If "PAGE," "INTERVAL (JOB)," or "INTERVAL (TIME)" is selected, ink buildup is removed before or during printing. Note, however, that using these settings results in longer printing times.

---

## Default Settings

---

[PERIODIC CL.]: NONE

## Using Sticky Media

### Procedure

---

- 1 Press [MENU].
- 2 Press [▼] several times to display the screen shown below.

```
MENU      <◆
SUB MENU  >
```

- 3 Press [▶] once, and then press [▼] several times to display the screen shown below.

```
SUB MENU  <◆
MEDIA RELEASE >
```

- 4 Press [▶] to display the screen shown below.

```
MEDIA RELEASE <◆
DISABLE >DISABLE ↓
```

- 5 Press [▲] or [▼] to select "ENABLE."

```
MEDIA RELEASE <◆
DISABLE >ENABLE ↓
```

- 6 Press [ENTER] to confirm your entry.
- 7 Press [MENU] to go back to the original screen.

---

### Description

---

Some types of media may tend to stick to the platen. Starting printing with the media sticking to the platen may make normal media feeding impossible and cause the media to jam. When using such media, set the [MEDIA RELEASE] menu item to "ENABLE." This peels off the media before starting printing if it is stuck to the platen. Note, however, that media feeding may be unstable when printing is performed after executing this operation. Leave this menu item set to "DISABLE" unless you specifically need to change it.

---

### Default Settings

---

[MEDIA RELEASE]: DISABLE

# Advanced Cutting Settings

## Fine-tuning the Cutting Conditions

### Procedure

- 1 **Carry out the cutting test.**  
⇒ P. 61 "Setting the Cutting Test and the Blade Force"
- 2 **When the cutting of the test pattern is finished, press [▼].**
- 3 **Check the results of the cutting test.**
  - **Check the cut shape.**  
The cut shape is distorted. ⇒ Decrease the value of [SPEED].

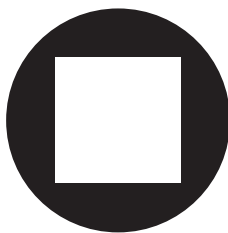

- **Peel off the circle.**

The square also peels off. ⇒ Increase the value of [FORCE].  
Some uncut areas remain. ⇒ Decrease the value of [SPEED].

- **Peel off the square.**

The blade leaves faint traces on the backing paper. ⇒ Do not change the value of [FORCE].  
The blade trace is indistinct. ⇒ Increase the value of [FORCE].  
The blade trace is too deep and cuts into the backing paper. ⇒ Decrease the value of [FORCE].

- **Check the shape of the square you have peeled off.**

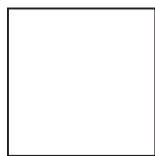

**A**

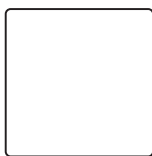

**B**

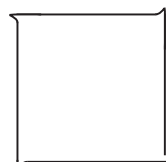

**C**

A ⇒ Do not change the value of [OFFSET].  
B (The corners are rounded.) ⇒ Increase the value of [OFFSET].  
C (The corners have "horns.") ⇒ Decrease the value of [OFFSET].

4

Advanced  
Functions

**4 Press [▲] or [▼] to select the cutting condition you want to set.**

Set the force (pressure) of the blade. (Default setting: 50 gf)

```
CUT CONFIG  ◀▶
FORCE       ▶
```

Set the speed of cutting. (Default setting: 30 cm/s)

```
CUT CONFIG  ◀▶
SPEED       ▶
```

Set the blade offset. Enter the listed offset value for the blade. (The offset value for the included blade is 0.25 mm (9.8 mil).) (Default setting: 0.250 mm)

```
CUT CONFIG  ◀▶
OFFSET      ▶
```

Set the blade's up speed during cutting (the speed at which the blade travels when it moves to the next cutting line after cutting one cutting line). If the media comes loose during no-load feed and the blade damages the surface of the media, reduce the speed. (Default setting: 30 cm/s)

```
CUT CONFIG  ◀▶
UP-SPEED    ▶
```

**5 Press [▶] to display the screen shown below.**

```
FORCE       ◀▶
50 gf ▶ 50 gf ◀
```

```
SPEED       ◀▶
30 cm/s ▶ 30 cm/s ◀
```

```
OFFSET      ◀▶
0.250mm ▶ 0.250mm ◀
```

```
UP-SPEED    ◀▶
20 cm/s ▶ 20 cm/s ◀
```

**6 Press [▲] or [▼] to select a value.****7 Press [ENTER] to confirm your entry.****8 Press [←] to go back to step 4.**

Repeat steps 4 and 5 to adjust the cutting conditions.

**9 Press [FUNCTION] to go back to the original screen.**

## Accurately Adjusting the Cutting-in Amount

When you want to perform accurate and fine adjustment of the cutting-in amount, such as when cutting media with thin backing paper, you can obtain good results by adjusting the amount of blade extension. Turn the cap portion of the blade holder to adjust the amount of blade extension. Each indicator tick corresponds to 0.1 mm (3.9 mil), and adjustment for 0.5 mm (19.7 mil) can be made by rotating the cap one full turn. Note that making the amount of blade extension too small may cause the tip of the blade holder cap to touch, and may soil and damage the printed surface. It is important to be especially careful about this when you are using media that has poor ink-adhesion properties.

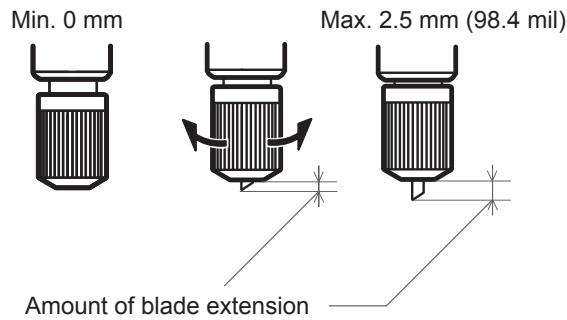

### 4

## Rough Estimate for the Amount of Blade Extension

Use the following dimension as a rough estimate for setting the amount of blade extension.

$$\text{Amount of blade extension} = \text{Thickness of the material portion} + \frac{\text{Thickness of the backing paper}}{2}$$

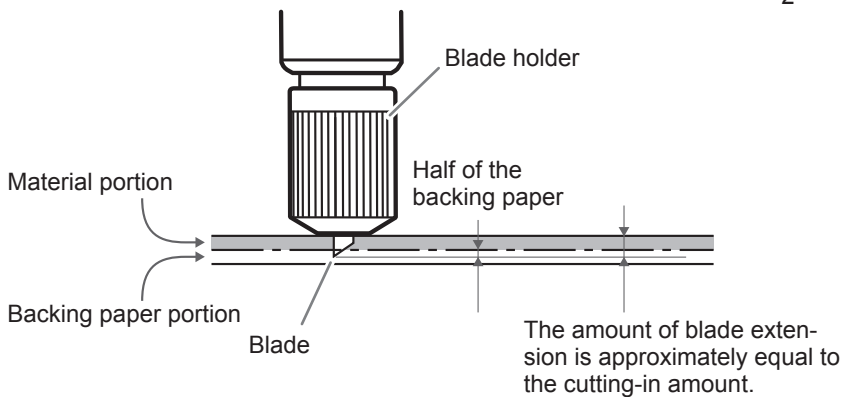

## Performing Distance Correction During Cutting

### Procedure

- 1 Make sure the [AUTO ENV. MATCH] menu item is set to "DISABLE."  
☞ P. 149 "Viewing the Automatic Environment Correction Function Settings"

- 2 Press [MENU].

- 3 Press [▲] to display the screen shown below.

```
MENU          ◀◆
CUTTING MENU ▶
```

- 4 Press [▶] once, and then press [▼] twice to display the screen shown below.

```
CUTTING MENU ◀◆
CALIBRATION  ▶
```

- 5 Press [▶] twice to display the screen shown below.

```
FEED SETTING ◀◆
 0.00% ▶ 0.00% ↵
```

- 6 Press [▲] or [▼] to select the correction value.  
Set the correction value of the media feed direction.

```
FEED SETTING ◀◆
 0.00% ▶ -0.10% ↵
```

- 7 Press [ENTER] to confirm your entry.

- 8 Press [←], then [▼] to display the screen shown below.

```
CALIBRATION  ◀◆
SCAN SETTING ▶
```

- 9 Press [▶] to display the screen shown below.

```
SCAN SETTING ◀◆
 0.00% ▶ 0.00% ↵
```

- 10 Press [▲] or [▼] to select the correction value.  
Set the correction value of the cutting carriage movement direction.

```
SCAN SETTING ◀◆
 0.00% ▶ -0.10% ↵
```

- 11 Press [ENTER] to confirm your entry.
- 12 Press [MENU] to go back to the original screen.

---

### Description

---

The movement distance of the media changes subtly depending on the media's thickness. This means that the length of a line when cut may differ from the length setting in the data. Enter the correction values when you want to accurately align the lengths of cut lines when performing only cutting.

---

### Default Settings

---

[FEED SETTING]: 0.00%  
 [SCAN SETTING]: 0.00%

## Correcting the Misalignment of the Printing and Cutting Positions

### 1. Perform the preparations before the correction.

---

- 1 Make sure the [AUTO ENV. MATCH] menu item is set to "ENABLE."  
☞ P. 149 "Viewing the Automatic Environment Correction Function Settings"
- 2 Perform bidirectional adjustment.  
☞ P. 131 "Correcting for Misalignment in Bidirectional Printing"

### 2. Perform a printing test.

---

- 1 Press [MENU].
- 2 Press [▲] to display the screen shown below.  

MENU	◀◆
CUTTING MENU	▶
- 3 Press [▶] to display the screen shown below.  

CUTTING MENU	◀◆
PRINT-CUT ADJ.	▶
- 4 Press [▶] to display the screen shown below.  

PRINT-CUT ADJ.	◀◆
TEST PRINT	↵
- 5 Press [ENTER].

The test pattern (P&C1) is printed and cut. The test pattern is printed at three locations on the media: at the two edges and in the center.

**6 Check the test pattern (P&C1).**

Check whether the printing position and the cutting position are aligned.

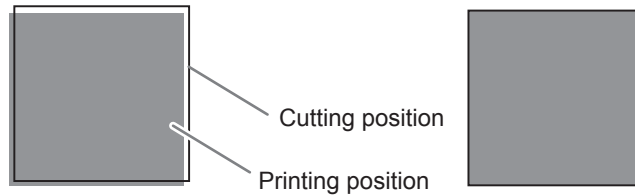

Printing position and cutting position are misaligned.

Printing position and cutting position are aligned.

If the printing position and the cutting position are aligned, no corrections are necessary.

If the printing position and the cutting position are not aligned, proceed to the next procedure.

**3. Set the correction values.**

**1 Press [▼] twice to display the screen shown below.**



**2 Press [ENTER].**

The test pattern (P&C2) is printed and cut.

**3 Press [▲] to display the screen shown below.**

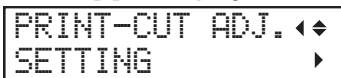

**4 Check the correction values from the test pattern (P&C2) condition.**

The point where the cutting line intersects the correction-value scale is the correction value. Check the scan direction (the direction of print head movement) and the feed direction (the media feed direction).

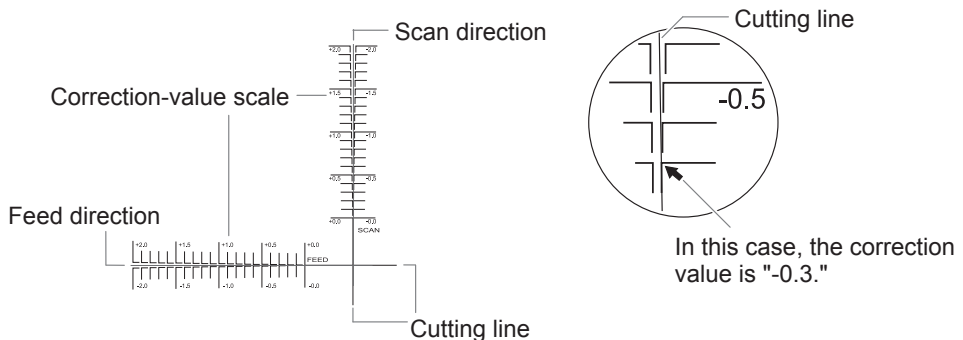

**5 Press [▶].**

**6** Set the correction values for the feed direction "F" and the scan direction "S."

① Press [▲] or [▼] to set the correction value for the feed direction (F).

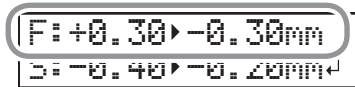

② Press [◀] or [▶] to set the correction value for the scan direction (S).

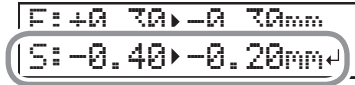

③ When you have finished setting the correction values, press [ENTER].

**7** Press [MENU], then [▲] to display the screen shown below.



**8** Press [ENTER].

The test pattern (P&C1) is printed and cut. If the printing and cutting lines are aligned, adjustment is complete. If further adjustment is needed, press [▼], then [▶] to go back to step **6** and fine-tune the adjustment.

**Description**

Perform this adjustment when printing followed immediately by cutting yields positioning for printing and cutting that is slightly misaligned. Print alignment marks, perform detection of the printed marks, and then correct the discrepancy. Subtle misalignment between the printing and cutting positions may occur due to the thickness of the media or the head height. We recommend that you make corrections to match the media you are using.

**Default Settings**

[F] (correction value of the media feed direction): 0.00 mm  
 [S] (correction value of the cutting carriage movement direction): 0.00 mm

**Prioritizing the Cutting Settings of This Machine over the Software RIP Settings**

**Procedure**

① Press [MENU].

② Press [▲] to display the screen shown below.

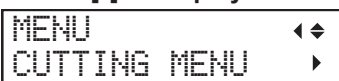

③ Press [▶] once, and then press [▼] several times to display the screen shown below.

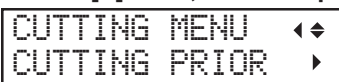

- 4 Press [▶] to display the screen shown below.

```
CUTTING PRIOR ◀◆
COMMAND▶COMMAND↵
```

- 5 Press [▲] or [▼] to select "MENU."

```
CUTTING PRIOR ◀◆
COMMAND▶MENU ↵
```

- 6 Press [ENTER] to confirm your entry.

- 7 Press [MENU] to go back to the original screen.

### Description

You can also make the settings for the cutting conditions in the software RIP. By default, the settings made with the software RIP take priority. To make the cutting conditions set on the machine take priority, either disable the software RIP settings or make the setting described above.

### Default Settings

[CUTTING PRIOR]: COMMAND

## Viewing the Automatic Environment Correction Function Settings

The automatic environment correction function performs automatic adjustments to the optimal condition of this machine according to the operating environment (humidity and temperature). Performing automatic adjustment reduces misalignment in the scanning direction (the direction of cutting carriage movement) during printing and cutting. Normally set this item to "ENABLE."

### Procedure

- 1 Press [MENU].

- 2 Press [▲] to display the screen shown below.

```
MENU ◀◆
CUTTING MENU ▶
```

- 3 Press [▶], then [▲] to display the screen shown below.

```
CUTTING MENU ◀◆
AUTO ENV. MATCH ▶
```

- 4 Press [▶] to display the screen shown below.

Check that the setting is "ENABLE."

```
AUTO ENV. MATCH ◀◆
ENABLE ▶ENABLE ↵
```

If you want to change the setting, press [▲] or [▼] to select "DISABLE."

- 5 Press [ENTER] to confirm your entry.
- 6 Press [MENU] to go back to the original screen.

---

**Default Settings**

---

[AUTO ENV. MATCH]: ENABLE

## Correcting the Misalignment of the Printing and Cutting Positions during Cutting

### Procedure

---

- 1 During cutting, press [PAUSE] to display the screen shown below.

```

TO CANCEL, HOLD
DOWN PAUSE KEY
    
```

The cutting operation is paused.

- 2 Press [FUNCTION].
- 3 Press [▼] several times to display the screen shown below.

```

FUNCTION          ◀◀
CUT CONFIG       ▶
    
```

- 4 Press [▶] once, and then press [▼] several times to display the screen shown below.

```

CUT CONFIG       ◀◀
PRINT-CUT ADJ.  ▶
    
```

- 5 Press [▶].
- 6 Determine the correction values.

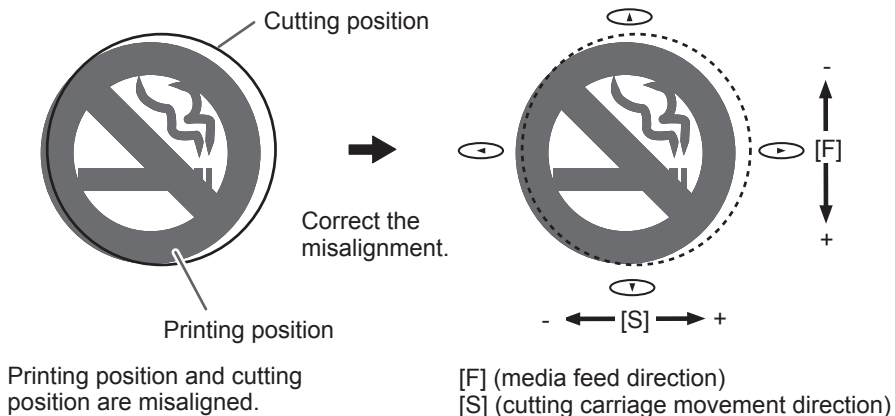

**7** Set the correction values for the feed direction "F" and the scan direction "S."

① Press [▲] or [▼] to set the correction value for the feed direction (F).

```
F: +0.30 ▶ -0.30mm
S: -0.40 ▶ -0.20mm ↵
```

② Press [←] or [→] to set the correction value for the scan direction (S).

```
F: +0.30 ▶ -0.30mm
S: -0.40 ▶ -0.20mm ↵
```

③ When you have finished setting the correction values, press [ENTER].

**8** Press [PAUSE] to display the screen shown below.

```
TO CANCEL, HOLD
DOWN PAUSE KEY
```

**9** Press [PAUSE] again to restart the cutting operation.

Hold down [PAUSE] for one second or longer to cancel the cutting operation.

☞ P. 79 "Pausing and Canceling Output"

**Description**

With this machine, you can pause a cutting operation to correct the misalignment of the printing and cutting positions. The correction values set here are applied as the default values of the printing and cutting positions. If the printing and cutting positions are misaligned, you normally adjust the positions while checking a test pattern.

☞ P. 146 "Correcting the Misalignment of the Printing and Cutting Positions"

**Default Settings**

[F] (correction value of the media feed direction): 0.00 mm

[S] (correction value of the cutting carriage movement direction): 0.00 mm

# Advanced Settings for Printing and Cutting with Crop Marks

## Aligning Positions Manually

Depending on the type of media, it may not be possible to detect crop marks automatically. When crop marks cannot be detected automatically, perform alignment manually.

The following figure is given as an example to explain how to manually set the base point and align points.

### MEMO

The numbers for align points are determined with reference to the location of the base point, as shown in the following figure. You cannot set the align points unless you specify the base point. Redoing the setting for the base point clears any align points that have been set.

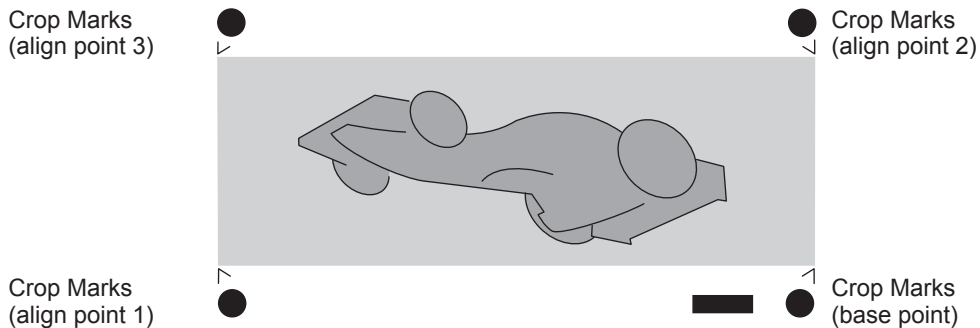

### 1. Set the base point.

- 1 Press [**←**], [**→**], [**▲**], or [**▼**] to move the center of the blade to the "base point" position.

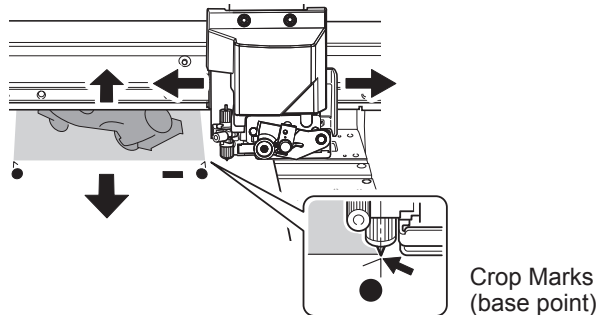

- 2 Press [**FUNCTION**] to display the screen shown below.



- 3 Press [**ENTER**].

The [**BASE POINT**] is set. The character "B" is displayed on the screen.

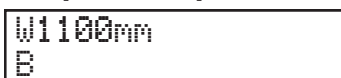

## 2. Set the align points.

- 1 Press [←], [→], [▲], or [▼] to move the center of the blade to the "align point 1" position.

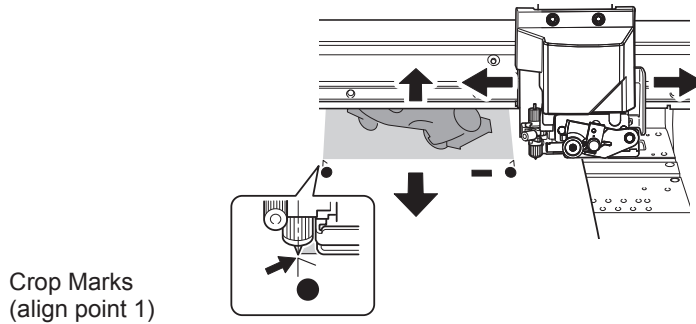

- 2 Press [FUNCTION] to display the screen shown below.

```
FUNCTION  < >
BASE POINT  ↵
```

- 3 Press [→] to display the screen shown below.

```
BASE POINT  ◀
ALIGN POINT 1  ↵
```

- 4 Press [ENTER].

The [ALIGN POINT] is set. The characters "B1" are displayed on the screen.

```
W1100mm
B1
```

- 5 Repeat steps 1 through 4 to specify "align point 2" and "align point 3" as required. The number of the align point you are setting is determined automatically.

## 3. Send the cutting data from the computer.

## Correcting Misalignment for Printing and Cutting When Using Crop Marks

### 1. Perform the preparations before the correction.

- 1 Make sure the [AUTO ENV. MATCH] menu item is set to "ENABLE."  
☞ P. 149 "Viewing the Automatic Environment Correction Function Settings"
- 2 Perform bidirectional adjustment.  
☞ P. 131 "Correcting for Misalignment in Bidirectional Printing"

### 2. Perform a printing test.

- 1 Press [MENU].
- 2 Press [▲] to display the screen shown below.

```
MENU      ◀◀
CUTTING MENU ▶
```

- 3 Press [▶], then [▼] to display the screen shown below.

```
CUTTING MENU ◀◀
CROP-CUT ADJ. ▶
```

- 4 Press [▶] to display the screen shown below.

```
CROP-CUT ADJ. ◀◀
TEST PRINT  ◀
```

- 5 Press [ENTER].

The test pattern (C&C1) is printed and cut. The test pattern is printed at three locations on the media: at the two edges and in the center.

- 6 Check the test pattern (C&C1).

Check whether the printing position and the cutting position are aligned.

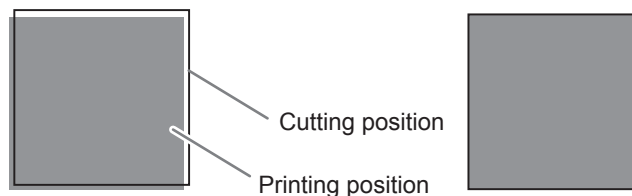

Printing position and cutting position are misaligned.

Printing position and cutting position are aligned.

If the printing position and the cutting position are aligned, no corrections are necessary.  
 If the printing position and the cutting position are not aligned, proceed to the next procedure.

### 3. Set the correction values.

- 1 Press [▼] twice to display the screen shown below.

```
CROP-CUT ADJ. ◀▶
TEST PRINT 2  ⏏
```

- 2 Press [ENTER].

The test pattern (C&C2) is printed and cut.

- 3 Press [▲] to display the screen shown below.

```
CROP-CUT ADJ. ◀▶
SETTING  ▶
```

- 4 Check the correction values from the test pattern (C&C2) condition.

The point where the cutting line intersects the correction-value scale is the correction value. Check the scan direction (the direction of print head movement) and the feed direction (the media feed direction).

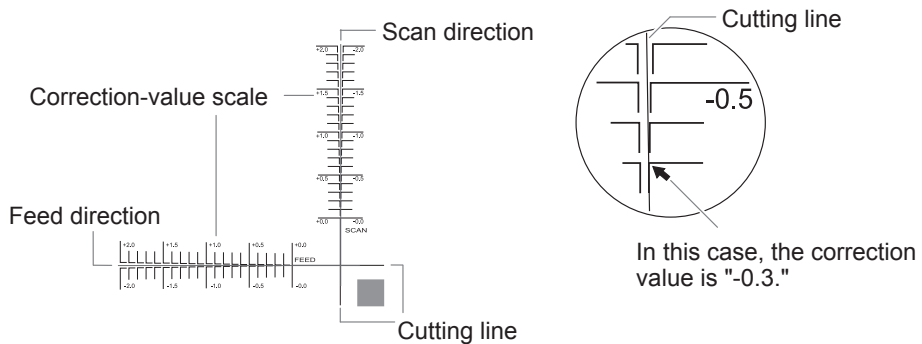

- 5 Press [▶].

- 6 Set the correction values for the feed direction "F" and the scan direction "S."

- 1 Press [▲] or [▼] to set the correction value for the feed direction (F).

```
F: +0.30 ▶ -0.30mm
S: -0.40 ▶ -0.20mm ⏏
```

- 2 Press [◀] or [▶] to set the correction value for the scan direction (S).

```
F: +0.30 ▶ -0.30mm
S: -0.40 ▶ -0.20mm ⏏
```

- 3 When you have finished setting the correction values, press [ENTER].

- 7 Press [MENU], then [▲] to display the screen shown below.

```
CROP-CUT ADJ. ◀◆
TEST PRINT      ↵
```

- 8 Press [ENTER].

The test pattern (C&C1) is printed and cut. If the printing and cutting lines are aligned, adjustment is complete. If further adjustment is needed, press [▼], then [▶] to go back to step 6 and fine-tune the adjustment.

---

### Description

---

Depending on the composition of the media, the positioning of printing and cutting may be misaligned even when you are using crop marks. Make corrections for misaligned printing and cutting for the media you are using.

---

### Default Settings

---

[F] (correction value of the media feed direction): 0.00 mm

[S] (correction value of the cutting carriage movement direction): 0.00 mm

# Using the Media Take-up Unit

## About the Media Take-Up Unit

- The media take-up unit (hereinafter referred to as the "take-up unit") is an optional item.
- For information on how to assemble, install, and operate the take-up unit, refer to the take-up unit user's manual.

# Performing Operations from Roland DG Mobile Panel

## What Is Roland DG Mobile Panel?

Roland DG Mobile Panel (hereinafter referred to as "Mobile Panel") is an application for mobile terminals. This application can be used to operate the machine by way of Bluetooth communication.

☞ P. 159 "Using Mobile Panel"

### Required System Environment

Supported operating systems	<ul style="list-style-type: none"><li>• iOS 8.0 or later</li><li>• Android 4.4 or later</li></ul> <p>* Mobile Panel may not work on some Android devices even if their operating system is version 4.4 or later.</p>
Supported languages	<ul style="list-style-type: none"><li>• Japanese</li><li>• English</li></ul>
Communication method	<ul style="list-style-type: none"><li>• Bluetooth 4.0 LE</li></ul> <p>* The mobile terminal you are using must support the above communication method.</p>

\* For the latest information, visit the Roland DG Corporation website (<http://www.rolanddg.com/>).

4

Advanced  
Functions

## Downloading Mobile Panel

### iPhone

#### Procedure

- 1 Search for "Roland DG Mobile Panel" in the App Store.
- 2 Tap "INSTALL APP" on the app details screen.

### Android

#### Procedure

- 1 Search for "Roland DG Mobile Panel" in Google Play.
- 2 Tap "INSTALL" on the app details screen.

## Using Mobile Panel

### Procedure

- 1 **Check that the machine's operation panel display shows one of the following screens.**  
If none of these screens is displayed, set up the media or press [MENU].

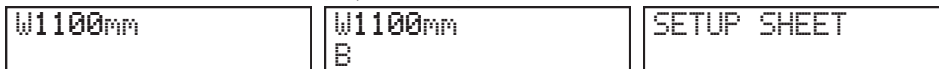

\* If you are using the optional take-up unit, "ROLL," "TU," or "TU2" is displayed below "SETUP SHEET."

- 2 **Turn on Bluetooth communication on the machine.**  
☞ P. 169 "Turning on Bluetooth Communication"
- 3 **Turn on Bluetooth communication on the mobile terminal you are using.**  
For information on how to configure the settings, refer to the documentation for the mobile terminal you are using.
- 4 **Start Mobile Panel.**  
Use Mobile Panel according to the instructions shown on your mobile terminal.

## Important Notes on Using Mobile Panel

### ***Number of printers that you can connect to***

You can only connect to one printer from a mobile terminal on which Mobile Panel has been installed. You can register multiple printers on Mobile Panel, but you cannot connect to multiple printers at the same time.

### ***No pairing is required***

Generally speaking, "pairing" is required to establish a Bluetooth connection. With Mobile Panel, no "pairing" is required. After starting Mobile Panel, follow the instructions on the screen to connect to the printer.

### ***Perform operations from a position where you can see the printer.***

To enable immediate handling of unexpected printer operations, perform Mobile Panel operations from a position where you can see the printer.

### ***Important notes on Bluetooth communication***

- With Bluetooth wireless technology, it is possible to establish a connection between devices separated by approximately 10 m (32.8 ft.). However, the valid range of the connection may vary depending on the presence of obstacles (such as people, metal, and walls) and the status of the radio waves.

- The communication status of the Bluetooth connection may become unstable if:
    - A wireless LAN is in place in the location.
    - The devices are in the vicinity of a microwave that is in use.
    - Other electromagnetic waves are generated in the location.
  - Bluetooth communication uses the same frequency band (2.4 GHz) as wireless LAN (IEEE802.11b/g). If the devices are used in the vicinity of equipment in which a wireless LAN unit is installed, the connection status may become unstable due to the occurrence of radio-frequency interference. In this situation, carry out the following countermeasures.
    - When using Bluetooth communication to connect the printer and the mobile terminal, do so at a distance of 10 m (32.8 ft.) or more away from the equipment in which a wireless LAN unit is installed.
    - Bring the mobile terminal and the printer as close together as possible.
    - If using Bluetooth communication within 10 m (32.8 ft.) of the equipment in which a wireless LAN unit is installed, turn off the wireless LAN unit.
  - The radio waves generated by Bluetooth communication may have an effect on the operation of electronic medical equipment and similar devices. This may lead to accidents, so turn off Bluetooth communication in the following locations.
    - The vicinity of in-use hearing aids and pacemakers
    - Hospitals
    - The vicinity of automatic doors and fire alarms
- ☞ P. 169 "Turning on Bluetooth Communication"
- Using Bluetooth communication in the vicinity of TVs or radios may lead to noise in the image or audio.
  - Roland DG Corporation accepts no responsibility for the leakage of information during a connection using Bluetooth technology.
  - The mobile terminal that you are using to connect to the printer must comply with Bluetooth standards determined by the Bluetooth SIG and must be a certified device.
  - Even if the mobile terminal complies with the Bluetooth standards outlined above, phenomena may occur due to the characteristics and specifications of the device. Examples of these phenomena include the inability to connect to the printer and the operation methods, display, and operations being different.
  - Depending on the mobile terminal that you are connecting to the printer, it may take some time until the Bluetooth connection can be established.
  - While the Bluetooth connection is established, do not cover the mobile terminal with your hand or anything else. Doing so may hinder the Bluetooth connection.

### **Other important notes**

---

- Bluetooth communication may increase the mobile terminal's battery consumption.
- Additional communication charges apply to the downloading of the application. You will have to bear the communication charges.
- Note that it may take time to confirm whether this application is supported by new mobile terminals.
- Depending on the usage environment, this application may not operate normally even with mobile terminals that have been confirmed to be supported.

# Other Useful Functions

## Using the Print Light (Interior Light)

### Procedure

- 1 Press [FUNCTION].
- 2 Press [▲] to display the screen shown below.

```
FUNCTION  <◆
PRINT LIGHT  >
```

- 3 Press [▶] to display the screen shown below.

```
PRINT LIGHT  <◆
  AUTO > AUTO  ↵
```

- 4 Press [▲] or [▼] to select the status of the print light.

```
PRINT LIGHT  <◆
  AUTO > ON    ↵
```

- 5 Press [ENTER] to confirm your entry.
- 6 Press [MENU] to go back to the original screen.

### Description

You can select the status of the light that shines on the platen.

**AUTO:** The light is turned on/off automatically according to the status of the printer.

**ON:** The light is on at all times.

**OFF:** The light is off at all times.

### Default Settings

[PRINT LIGHT]: AUTO

## Performing Printing Tests Arranged Horizontally

### Procedure

- 1 Press [MENU].
- 2 Press [▼] several times to display the screen shown below.

```
MENU  <◆
SUB MENU  >
```

- 3 Press [▶], then [▲] to display the screen shown below.



- 4 Press [▶] to display the screen shown below.



- 5 Press [▲] or [▼] to select "FEED."



- 6 Press [ENTER] to confirm your entry.

- 7 Press [MENU] to go back to the original screen.

### Description

When performing printing tests successively, you can select "SCAN" (vertical printing) or "FEED" (horizontal printing) as the print position for the 2nd and later tests in comparison to the 1st test. If you are using the optional media take-up unit, test prints will be printed with the "SCAN" orientation regardless of this setting.

### Default Settings

[TEST PRINT POS]: SCAN

## Using Media Flanges for Paper Tubes (Cores) with an Internal Diameter of 2 Inches

- \* The media flanges for paper tubes (cores) with an internal diameter of 2 inches are optional items. For information about purchasing items, contact your authorized Roland DG Corporation dealer.

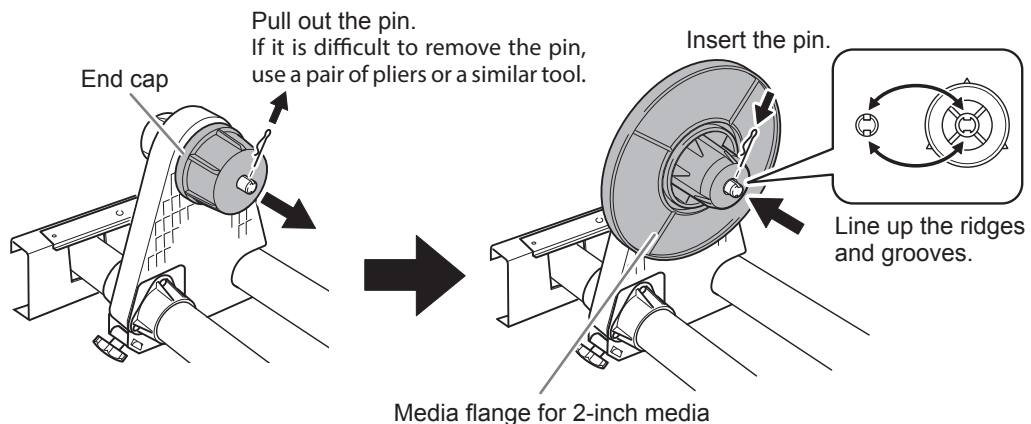

# Chapter 5 Administrator Menu

---

Output Operation Management .....	164
Printing a System Report.....	164
Determining What Happens When Ink Runs Out .....	164
Displaying the Amount of Media Remaining.....	165
Making Sure to Verify the Setting for the Amount Remaining Every Time the Media Is Changed ..	166
Printing the Amount of Remaining Media .....	167
Thoroughly Using the Middle Pinch Rollers.....	168
System Management of the Printer .....	169
Setting the Menu Language and Units of Measurement .....	169
Turning on Bluetooth Communication .....	169
Setting the Activation Interval for Sleep Mode (Power-saving Feature) .....	171
Viewing System Information .....	172
Returning All Settings to Factory Defaults .....	173
When Moving the Unit.....	174
Procedures from Preparing to Move Through Reinstalling.....	174

# Output Operation Management

## Printing a System Report

This prints system information, including a list of setting values.

### Procedure

- 1 Press [MENU].
- 2 Press [▼] several times to display the screen shown below.

```
MENU      ◀◆
SUB MENU  ▶
```

- 3 Press [▶] once, and then press [▼] several times to display the screen shown below.

```
SUB MENU  ◀◆
SYSTEM REPORT  ↵
```

- 4 Press [ENTER].  
The printing of the system report starts.
- 5 Press [MENU] to go back to the original screen.

## Determining What Happens When Ink Runs Out

This menu lets you change, according to your purpose, the operation that takes place when an ink pouch is empty.

### MEMO

This function is not available when you are using four colors (CMYK).

### Procedure

- 1 Press [MENU].
- 2 Press [▼] several times to display the screen shown below.
- 3 Press [▶] once, and then press [▼] several times to display the screen shown below.

```
MENU      ◀◆
SUB MENU  ▶
```

```
SUB MENU  ◀◆
INK CONTROL  ▶
```

- 4 Press [▶] twice to display the screen shown below.

```
EMPTY MODE  ◀◆
STOP      ▶ STOP  ⏏
```

- 5 Press [▲] or [▼] to select a setting.

```
EMPTY MODE  ◀◆
STOP      ▶ CONT. ⏏
```

<b>STOP</b>	Printing is paused immediately when an ink pouch becomes empty.
<b>CONT.</b>	Printing does not stop automatically when an ink pouch becomes empty. A warning beep goes off when an ink pouch becomes empty.

- 6 Press [ENTER] to confirm your entry.
- 7 Press [MENU] to go back to the original screen.

### Description

When "STOP" is selected, printing pauses, so colors may be uneven. Ensure that the remaining ink is sufficient before you begin printing. When "CONT" is selected, printing does not stop even if ink runs out completely. To replace an ink pouch, wait until printing ends or press [PAUSE] to pause printing.

### Default Settings

[EMPTY MODE]: STOP

## Displaying the Amount of Media Remaining

You can display how much of the media in use is left. By setting the amount of media currently remaining at the start, the amount remaining will be constantly displayed on the screen until it reaches zero.

### Procedure

- 1 Press [MENU].
- 2 Press [▼] several times to display the screen shown below.

```
MENU  ◀◆
SHEET REMAIN  ▶
```

- 3 Press [▶], then [▼] to display the screen shown below.

```
SHEET REMAIN  ◀◆
SET LENGTH    ▶
```

- 4 Press [▶] to display the screen shown below.



- 5 Press [▲] or [▼] to set the current amount of media remaining.



- 6 Press [ENTER] to confirm your entry.

- 7 Press [MENU] to go back to the original screen.



This display is updated.



If media has not been loaded,  
the set value flashes.

## Description

If you cancel media loading, for example by removing the media or raising the loading lever, the amount remaining at that time flashes on the screen. Because the amount of media remaining is not updated automatically when you change the media, redo the setting whenever you change the media. You can also set the machine to display this menu automatically whenever you change the media. See the next section, "Making Sure to Verify the Setting for the Amount Remaining Every Time the Media Is Changed."

\* The remaining amount that is displayed is only an estimate. Accuracy is not assured.

## Making Sure to Verify the Setting for the Amount Remaining Every Time the Media Is Changed

Set the machine to display the amount of media remaining every time the media is changed.

### Procedure

- 1 Press [MENU].
- 2 Press [▼] several times to display the screen shown below.



- 3 Press [▶], then [▲] to display the screen shown below.

```
SHEET REMAIN  ◀◆
AUTO DISPLAY  ▶
```

- 4 Press [▶] to display the screen shown below.

```
AUTO DISPLAY  ◀◆
DISABLE▶DISABLE◀
```

- 5 Press [▲] or [▼] to select "ENABLE."

```
AUTO DISPLAY  ◀◆
DISABLE▶ENABLE◀
```

- 6 Press [ENTER] to confirm your entry.

If you select "ENABLE," you must set the [EDGE DETECTION] menu to "ENABLE."

☞ P. 136 "Using Transparent Media"

- 7 Press [MENU] to go back to the original screen.

---

### Description

---

Setting this menu item to "ENABLE" can keep you from forgetting to redo the setting when you change the media. However, be sure to also set the [EDGE DETECTION] menu item to "DISABLE" (P. 136 "Using Transparent Media"). When [EDGE DETECTION] is set to "DISABLE," [SHEET REMAIN] is not displayed automatically.

---

### Default Settings

---

[AUTO DISPLAY]: DISABLE

## Printing the Amount of Remaining Media

This prints the amount of media remaining, which is displayed on the top menu.

### Procedure

---

- 1 Press [MENU].

- 2 Press [▼] several times to display the screen shown below.

```
MENU  ◀◆
SHEET REMAIN  ▶
```

- 3 Press [▶] to display the screen shown below.

```
SHEET REMAIN  ◀◆
PRINT MEMO  ◀
```

- 4 Press [ENTER].

Start printing.

- 5 Press [MENU] to go back to the original screen.

---

### Description

---

Use this when you want to make a record of the remaining length of the media currently in use. Printing the amount of media remaining before you change the media enables you to refer to the printed record and use the value to make the setting for the remaining amount the next time you use the media.

Note, however, that if you continue printing, the next printing operation will start on top of the portion where the amount of remaining media is printed. If you want to continue printing, cut off the media before starting the next printing operation.

## Thoroughly Using the Middle Pinch Rollers

This menu lets you enable the checking function to make sure the operators who perform output will use the middle pinch rollers.

### Procedure

---

- 1 Press [MENU].
- 2 Press [▼] several times to display the screen shown below.

```
MENU      ◀◀
SUB MENU  ▶
```

- 3 Press [▶] once, and then press [▼] several times to display the screen shown below.

```
SUB MENU  ◀◀
M.PINCH CHECK ▶
```

- 4 Press [▲] or [▼] to select "ENABLE."

```
M.PINCH CHECK ◀◀
DISABLE ▶ ENABLE ↵
```

- 5 Press [ENTER].
- 6 Press [MENU] to go back to the original screen.

---

### Description

---

When this is set to "ENABLE," the message "SOME MID.PINCHS NOT SET RIGHT" is displayed if the user forgets to place the middle pinch rollers during setup. Press [ENTER] to clear the message and complete the setup. Failing to use the middle pinch rollers will cause the media feeding accuracy to drop and the media to come loose, which will lead to a decrease in the output quality. If the message is displayed, we recommend that you raise the loading lever and perform the operations again from P. 34 "4. Secure the media in place."

---

### Default Settings

---

[M.PINCH CHECK]: DISABLE

# System Management of the Printer

## Setting the Menu Language and Units of Measurement

This feature sets the language and units of measurement displayed on the display screen of the operation panel.

### Procedure

- 1 Hold down [MENU] and switch on the sub power.
- 2 Press [▲] or [▼] to select the display (menu) language.

```
MENU LANGUAGE  ◆
ENGLISH        ↵
```

- 3 Press [ENTER] to confirm your entry.
- 4 Press [▲] or [▼] to select the measurement unit for length.

```
LENGTH UNIT    ◆
mm             ↵
```

- 5 Press [ENTER] to confirm your entry.
- 6 Press [▲] or [▼] to select the measurement unit for temperature.

```
TEMP. UNIT     ◆
°C             ↵
```

- 7 Press [ENTER] to confirm your entry.

### Default Settings

[MENU LANGUAGE]: ENGLISH  
[LENGTH UNIT]: mm  
[TEMP. UNIT]: °C

## Turning on Bluetooth Communication

- \* There are some precautions regarding Bluetooth communication. Refer to P. 159 "Important notes on Bluetooth communication" for details.

### Procedure

- 1 Press [MENU].
- 2 Press [▼] several times to display the screen shown below.

```
MENU           ◆◆
SYSTEM INFO.   ▶
```

- 3 Press [▶] once, and then press [▼] several times to display the screen shown below.

```
SYSTEM INFO.  ◀◆
BLUETOOTH    ▶
```

- 4 Press [▶] twice to display the screen shown below.

```
BLUETOOTH    ◀◆
DISABLE▶DISABLE◀
```

- 5 Press [▲] or [▼] to select "ENABLE."

```
BLUETOOTH    ◀◆
DISABLE▶ENABLE◀
```

- 6 Press [ENTER] to confirm your entry.

- 7 Press [◀] to display the screen shown below.

The current state is displayed on the screen.

```
BLUETOOTH    ◀
ENABLE       ▶
```

- 8 Press [MENU] to go back to the original screen.

### Description

This machine supports "Roland DG Mobile Panel" (hereinafter referred to as "Mobile Panel"), which is an application for mobile terminals.

When using Mobile Panel, set this machine's Bluetooth communication to "ENABLE." However, when you are operating this machine from its operation panel, you cannot perform operations from Mobile Panel.

☞ P. 158 "Performing Operations from Roland DG Mobile Panel"

The states that are displayed on the screen in step 7 are shown below.

<b>ENABLE</b>	Bluetooth communication is on, and the printer is waiting for a connection to be established. If you cannot operate the printer from Mobile Panel, there is a problem with the connection environment. ☞ P. 193 "Printer Cannot Be Operated from Mobile Panel"
<b>ENABLE*</b>	Bluetooth communication is on, and the printer is connected to Mobile Panel. * However, when this screen is displayed, you cannot perform operations from Mobile Panel. ☞ P. 158 "Performing Operations from Roland DG Mobile Panel"
<b>DISABLE</b>	Bluetooth communication is off.
<b>ERROR</b>	An error has occurred in Bluetooth communication. Purchase them from your authorized Roland DG Corporation dealer.

### Default Settings

[BLUETOOTH]: DISABLE

## Setting the Activation Interval for Sleep Mode (Power-saving Feature)

### Procedure

- 1 Press [MENU].
- 2 Press [▼] several times to display the screen shown below.

```
MENU      ◀◀
SUB MENU  ▶
```

- 3 Press [▶] once, and then press [▼] several times to display the screen shown below.

```
SUB MENU  ◀◀
SLEEP     ▶
```

- 4 Press [▶] twice to display the screen shown below.

```
INTERVAL  ◀◀
 30min ▶ 30min ◀
```

- 5 Press [▲] or [▼] to set the time.

```
INTERVAL  ◀◀
 30min ▶ 15min ◀
```

- 6 Press [ENTER] to confirm your entry.
- 7 Press [MENU] to go back to the original screen.

### Default Settings

[INTERVAL]: 30min

## Viewing System Information

- \* For information on how to set up a network, see the "Setup Guide."
- \* Refer to P. 169 "Turning on Bluetooth Communication" for information on how to set up Bluetooth communication.

### Procedure

- 1 Press [MENU].
- 2 Press [▼] several times to display the screen shown below.

```

MENU          ◀▶
SYSTEM INFO. ▶
    
```

You can check the following information.

- [MODEL]: Model name
- [SERIAL NO.]: Serial Number
- [INK]: Ink type
- [FIRMWARE]: Firmware version
- [NETWORK]: Network settings such as the IP address
- [BLUETOOTH]: Bluetooth communication state

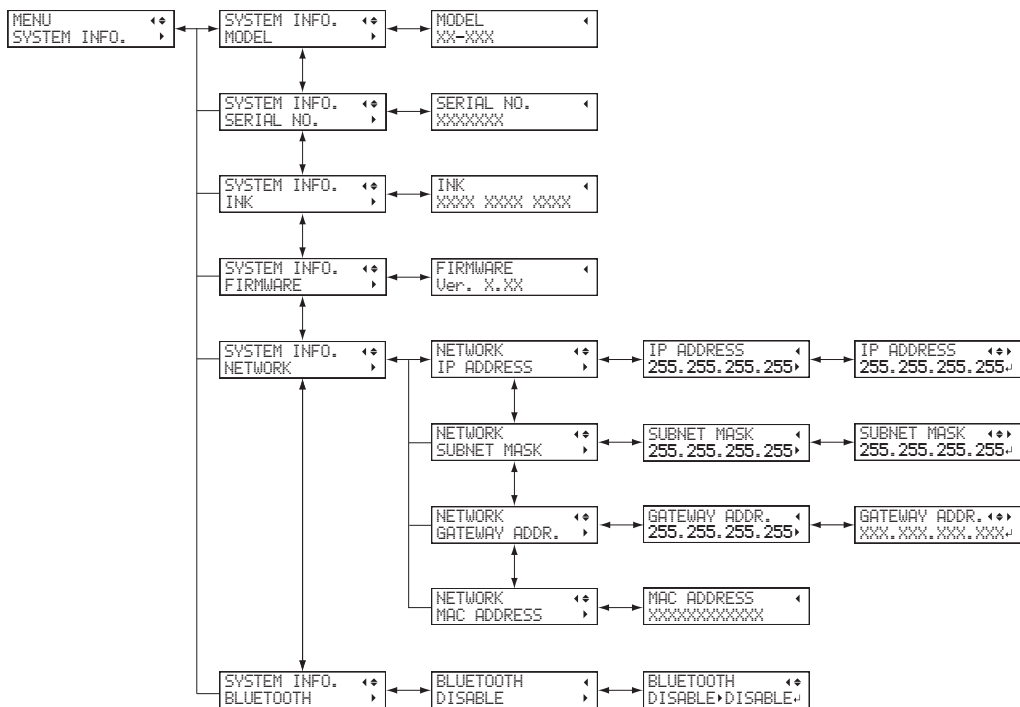

## Returning All Settings to Factory Defaults

This menu returns all settings to the same as their factory defaults. However, the settings for [MENU LANGUAGE], [LENGTH UNIT], and [TEMP. UNIT] are not returned to their factory default values.

### Procedure

- 1 Press [MENU].
- 2 Press [▼] several times to display the screen shown below.

```
MENU      ◀◀
SUB MENU  ▶
```

- 3 Press [▶] once, and then press [▼] several times to display the screen shown below.

```
SUB MENU  ◀◀
FACTORY DEFAULT ↵
```

- 4 Press [ENTER] to execute the operation.

# When Moving the Unit

## Procedures from Preparing to Move Through Reinstalling

Before moving the machine, dispose of the discharged fluid and secure the print heads in place. Attempting to move the machine without first performing these preparations may result in damage to internal components due to leaking ink or damage to the print heads.

### IMPORTANT

- Once the preparations for moving the machine are complete, move the machine promptly and turn on the machine as soon as possible after the machine is relocated. If you leave the machine alone without turning it on, the precipitated ink will coagulate and result in problems such as the clogging of the print heads.
- When moving the machine, keep it at a temperature from 5 to 40°C (41 to 104°F) and at a humidity from 20 to 80% (with no condensation). Failure to do so may result in a breakdown.
- Handle the machine with care when moving it, keeping it level (not tilted at an angle) and preventing it from striking other objects.

### 1. Remove any media and the blade holder.

#### 1 Remove any media.

If any media has been loaded, remove it.

If no media is loaded, raise the loading lever.

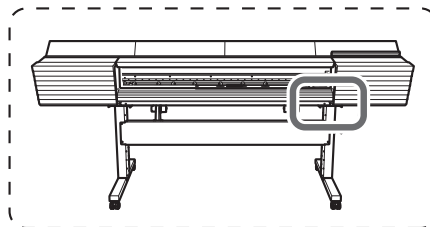
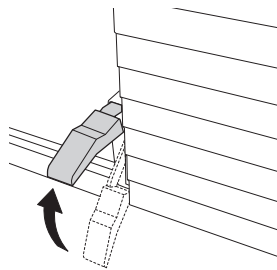

#### 2 Press [MENU].

#### 3 Press [▼] several times to display the screen shown below.

```
MENU      ◀◆
SUB MENU  ▶
```

#### 4 Press [▶] once, and then press [▼] several times to display the screen shown below.

```
SUB MENU  ◀◆
MAINTENANCE ▶
```

#### 5 Press [▶] once, and then press [▼] several times to display the screen shown below.

```
MAINTENANCE ◀◆
REPLACE KNIFE ↓
```

**6 Press [ENTER].**

The cutting carriage moves to a position where blade replacement is possible.

**7 When the following screen is displayed, open the front cover.**

```
OPEN FRONT
COVER
```

Preparation is complete once the following screen is displayed.

```
FINISHED?
↵
```

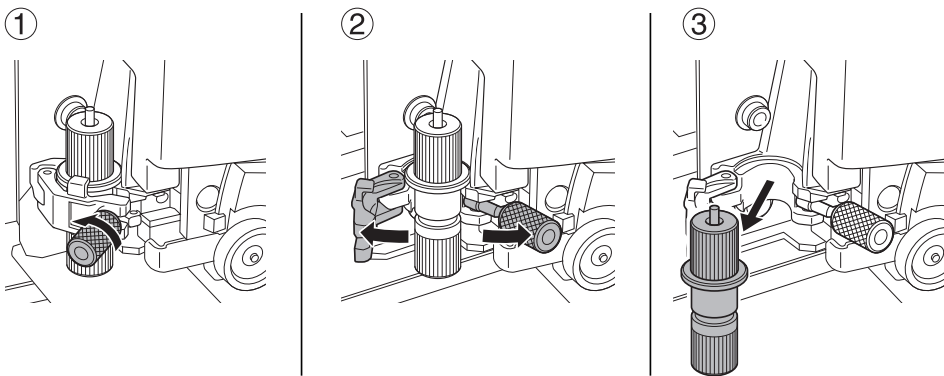
**8 Detach the blade holder.****2. Only when using white ink: Circulate the ink.**

- \* This work is not necessary when using seven colors (CMYKLcLmLk) or four colors (CMYK). Proceed to step **3**. ("Discharge the wiper tray cleaning liquid.")

**1 Press [MENU].****2 Press [▼] several times to display the screen shown below.**

```
MENU      ◀▶
SUB MENU  ▶
```

**3 Press [▶] once, and then press [▼] several times to display the screen shown below.**

```
SUB MENU  ◀▶
INK CONTROL ▶
```

**4 Press [▶] once, and then press [▼] several times to display the screen shown below.**

```
INK CONTROL ◀▶
CIRCULATE INK ↵
```

**5 Press [ENTER].**

The screen shown below appears, and then the ink circulation starts. The (approximate) remaining time for the procedure is displayed on the screen. (The display shown below is an example. "01:45" = "1 minute and 45 seconds")

```
CIRCULATING INK
>>          01:45
```

Depending on the timing with which the ink circulation is started, the following screen may be displayed and cleaning may start. When cleaning is complete, the ink circulation will start, so wait for the ink circulation to complete. (The display shown below is an example. "01:45" = "1 minute and 45 seconds")

```
CLEANING...
>>          01:45
```

When finished, the screen shown below appears again.

```
INK CONTROL  ◀◆
CIRCULATE INK  ↵
```

**3. Enter the menu for discharging the wiper tray cleaning liquid.**

**1 Press [MENU].**

**2 Press [▼] several times to display the screen shown below.**

```
MENU          ◀◆
SUB MENU      ▶
```

**3 Press [▶] once, and then press [▼] several times to display the screen shown below.**

```
SUB MENU     ◀◆
MAINTENANCE  ▶
```

**4 Press [▶] once, and then press [▼] several times to display the screen shown below.**

```
MAINTENANCE  ◀◆
DRAIN TRAY   ↵
```

**5 Press [ENTER].**

- 6 When the screen shown below appears, remove the drain bottle and discard the discharged fluid.

```
EMPTY
DRAIN BOTTLE ↵
```

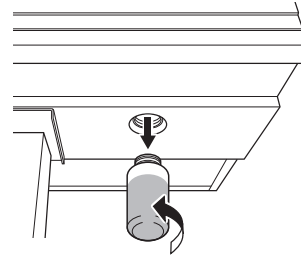
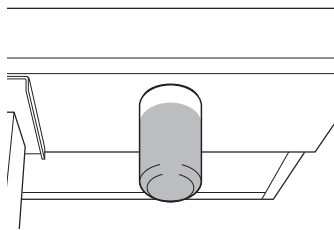

#### IMPORTANT

When you remove the drain bottle, a few drops of discharged fluid may come out of the machine. Exercise caution to prevent this fluid from soiling your hands or the floor.

#### ⚠ CAUTION

**Before you detach the drain bottle, be sure to wait for the screen to display "EMPTY DRAIN BOTTLE." After discarding the discharged fluid, promptly attach the drain bottle to the machine.**

Failing to follow this procedure may cause discharged fluid to flow out of the tube and spill, soiling your hands or the floor.

#### ⚠ WARNING

**Never place discharged fluid or ink near an open flame.**

Doing so may cause fire.

#### ⚠ CAUTION

**To store discharged fluid temporarily, place it in the included drain bottle or in a durable sealed container such as a metal can or polyethylene tank, and cap the container tightly.**

Any spillage or vapor leakage may cause fire, odor, or physical distress.

**Dispose of discharged fluid properly, in accordance with the laws in effect in your locale.**

Discharged fluid is flammable and contains toxic ingredients. Never attempt to incinerate discharged fluid or discard it with ordinary trash. Also, do not dispose of it in sewer systems, rivers, or streams. Doing so may have an adverse impact on the environment.

- 7 Attach the emptied drain bottle to the machine once more.

- 8 Press [ENTER].

4. Discharge the cleaning liquid.

- 1 When the following screen is displayed, open the right cover.

OPEN COVER R

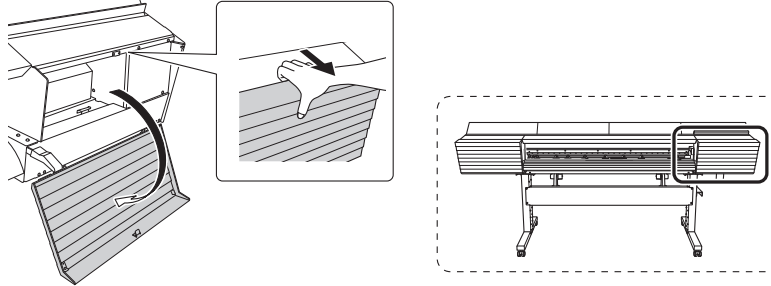

- 2 When the following screen is displayed, open the drain valve.

OPEN  
WASTE VALVE

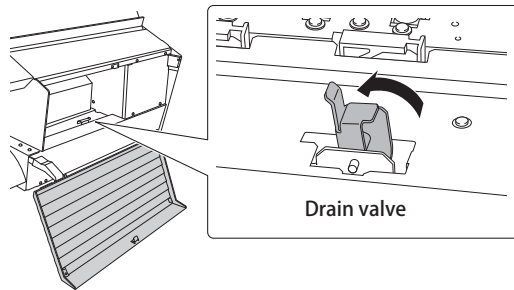

- 3 When the following screen is displayed, close the right cover.

CLOSE COVER R

- 4 When the following screen is displayed, open the right cover.

OPEN COVER R

- 5 When the following screen is displayed, close the drain valve.

CLOSE  
WASTE VALVE

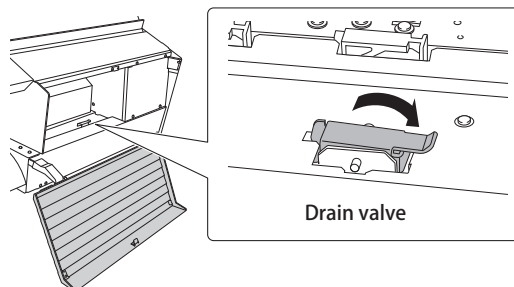

- 6 When the following screen is displayed, close the right cover.

CLOSE COVER R

The sub power turns off automatically.

- 7 Turn off the main power switch.
- 8 Remove the drain bottle and discard the discharged fluid.

#### IMPORTANT

When you remove the drain bottle, a few drops of discharged fluid may come out of the machine. Exercise caution to prevent this fluid from soiling your hands or the floor.

**⚠ WARNING** Never place discharged fluid or ink near an open flame. Doing so may cause fire.

**⚠ CAUTION** To store discharged fluid temporarily, place it in the included drain bottle or in a durable sealed container such as a metal can or polyethylene tank, and cap the container tightly. Any spillage or vapor leakage may cause fire, odor, or physical distress.

- 9 Attach the emptied drain bottle to the machine once more.

## 5. Secure the print heads in place using the retainer.

Use the retainer that was attached to the bottom of the machine during its installation.

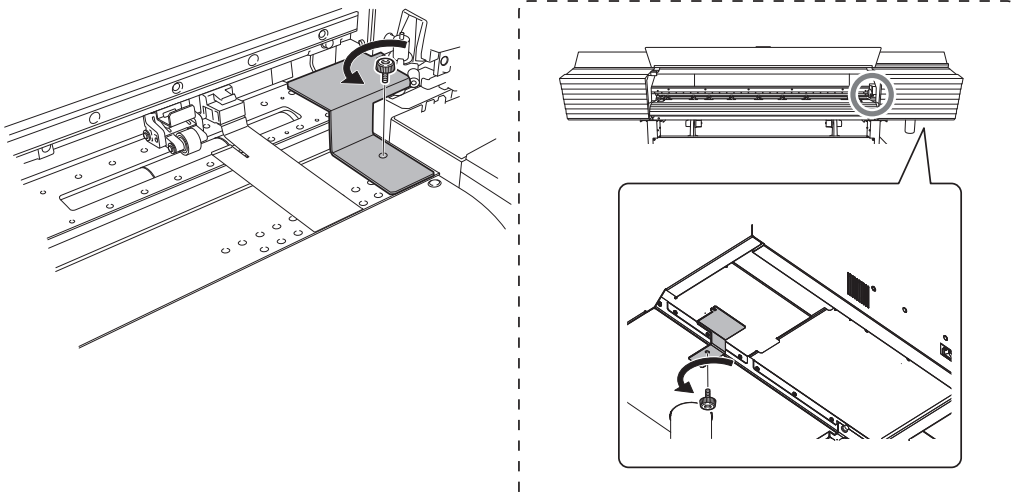

## 6. Relocate the machine.

- 1 Once the preparations are complete, move the machine with as little delay as possible.
- 2 Reinstall the printer immediately, and then remove the retainer securing the print heads in place.

For storage, attach the retainer in the position indicated in the figure.

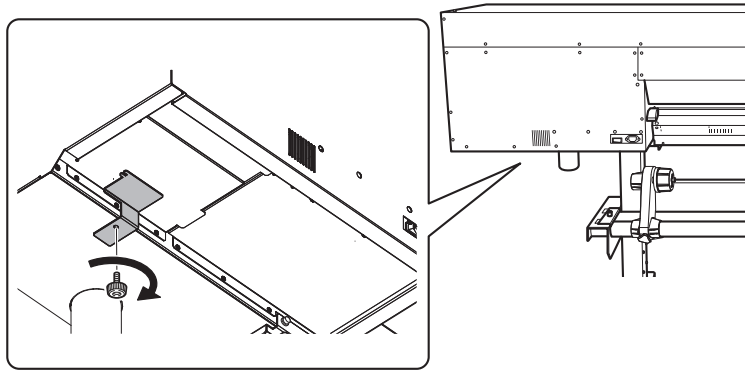

- 3 Turn on the main power switch.

### IMPORTANT

To prevent the print heads from being damaged, move the machine with as little delay as possible and switch on the main power as soon as possible after moving the machine. To install the machine again, follow the procedure in the Setup Guide.

- 4 Press the sub power button.
- 5 Press [ENTER] when the following screen appears.

```
WIPER TRAY  
IS NOT FILLED↵
```

The screen shown below appears, and then the machine is filled with TR cleaning liquid. The (approximate) remaining time for the procedure is displayed on the screen. (The display shown below is an example. "01:40" = "1 minute and 40 seconds.")

```
FILLING LIQUID  
>>>> 01:40
```

Once the machine is filled with TR cleaning liquid, the following screen is displayed and the power turns on.

```
SETUP SHEET
```

# Chapter 6 Troubleshooting

---

Attractive Printing or Cutting Is Impossible .....	182
Printed Results Are Coarse or Contain Horizontal Stripes .....	182
The Media Becomes Soiled When Printed .....	183
Colors Are Unstable or Uneven .....	184
Cutting Is Misaligned or Skewed .....	185
A Media Jam Occurs! .....	186
The Media Has Jammed .....	186
Media Feed Is Not Smooth .....	187
Media Wrinkles or Shrinks .....	187
Media Feeding Is Not Straight .....	188
Media Feeding Is Not Smooth .....	188
The Print Heads Do Not Move .....	189
What to Do First .....	189
If the Heads Still Do Not Move .....	189
Other Problems .....	191
The Printer Unit Does Not Run .....	191
The Media Heating System Doesn't Warm Up .....	192
Cannot Cut Off the Media .....	192
It Is Not Possible to Check the Amount of Discharged Fluid in the Drain Bottle.....	193
Printer Cannot Be Operated from Mobile Panel .....	193
A Message Appears .....	195
An Error Message Appears .....	197

# Attractive Printing or Cutting Is Impossible

## Printed Results Are Coarse or Contain Horizontal Stripes

**Do the print heads show dot drop-out?**

Carry out a printing test and make sure no dot drop-out occurs. If dot drop-out is present, perform head cleaning.

P. 53 "Step 5 : Printing Tests and Normal cleaning"  
P. 88 "When Normal Cleaning Is Not Effective"

**Is the print head height appropriate?**

Printing when the [HEAD HEIGHT] menu item is set to "HIGH" is coarser than when set to "LOW." Keep this set to "LOW" except when changing it is necessary, such as when you are using thick media.

P. 135 "Adjusting Print Head Height to Match Media Thickness"

**Have you carried out feed correction?**

Large misalignment in the amount of feed of the media may result in printing that seems coarse or contains horizontal stripes. Either make the setting in the software RIP to match the type of media you are using, or make the setting for correction on the printer.

P. 133 "Reducing Horizontal Bands (Feed Correction Function)"

**Have you carried out bidirectional correction?**

When you are performing bidirectional printing, use the [ADJUST BI-DIR] menu item to carry out correction. The optimal adjustment value may vary depending mainly on the thickness of the media. Set or select an adjustment value that is suitable for the media. When further correction is required, such as when adjustment made using [SIMPLE SETTING] does not enhance printing, use [DETAIL SETTING] to make the correction.

P. 131 "Correcting for Misalignment in Bidirectional Printing"  
P. 132 "Correcting for Misalignment in Bidirectional Printing More Precisely"

**Is the printer installed in a level and stable location?**

Never install the machine in a location where it is tilted or where it may wobble or experience vibration. Also make sure that the print heads are not exposed to moving air. These factors may lead to dot-dropout or reduced printing quality.

**Is the media heating system at a suitable temperature?**

If the ink forms lumps or smudges, raise the temperature. Note, however, that a temperature that is too high may degrade the media or cause it to wrinkle.

P. 123 "Settings for the Media Heating System"

**Is the temperature of the room too low?**

The media heating system may not warm up sufficiently when the ambient temperature is less than 20°C (68°F). Also, even when the media heating system reaches its set temperatures, adequate effectiveness may not be apparent if the media is thoroughly chilled. Before printing, allow the media to come to room temperature.

<p><b>Is the print mode suitable?</b></p>		<p>If attractive printing is impossible even when the media heating system is at a high temperature, try using a higher-quality print mode. Depending on the media, smudging may occur when using a high-quality print mode, and results may also vary greatly depending on the settings of your software RIP (such as the color-profile selection). Select settings appropriate for the media you are using.</p>
<p><b>Is the media loaded correctly?</b></p>		<p>If the media is not loaded correctly or the media feed is not smooth, printing may be adversely affected. Load the media correctly.</p> <p>P. 187 "Media Feed Is Not Smooth"</p>
<p><b>Are the settings for the [PRESET] menu item appropriate?</b></p>		<p>If the settings selected with the [PRESET] menu item are not suitable for the type of media, printing may be adversely affected. Choose settings optimized for the media you are using.</p> <p>P. 39 "Step 3 : Batch Settings" P. 120 "Using Presets"</p>

## The Media Becomes Soiled When Printed

<p><b>Do the print heads come into contact with the media?</b></p>		<p>The height of the print heads may be too low. Also, if the media is not loaded and set up correctly, it may wrinkle or come loose and contact the print heads.</p> <p>P. 135 "Adjusting Print Head Height to Match Media Thickness" P. 187 "Media Feed Is Not Smooth"</p>
<p><b>Are the print heads dirty?</b></p>		<p>The following may cause ink to drip on the media during printing.</p> <ul style="list-style-type: none"> <li>• Buildup of fibrous dust (lint) around the heads</li> <li>• Ink transferred to the heads due to rubbing against the media</li> </ul> <p>If this happens, clean the print heads manually. We recommend carrying out periodic head cleaning.</p> <ul style="list-style-type: none"> <li>• Too low humidity</li> </ul> <p>Use the machine in an environment with a humidity of 35 to 80%RH (no condensation).</p> <p>P. 90 "Manual Cleaning"</p>
<p><b>Are the pinch rollers or the media clamps dirty?</b></p>		<p>Periodically clean them.</p> <p>P. 82 "Cleaning"</p>

## Colors Are Unstable or Uneven

**Have you tried mixing the ink by shaking the pouch trays?**

If colors are uneven, remove the pouch trays, and then shake them gently.

P. 97 "Mixing the Ink by Shaking the Pouch Tray"

If uneven color issues with white ink are not resolved even after shaking the pouch trays to mix the ink, perform "damper cleaning."

P. 97 "Damper Cleaning (When Uneven Color Issues Occur with White Ink)"

If uneven color issues with ink other than white ink (LcLmLk ink or CMYK ink) are not resolved even after shaking the pouch trays to mix the ink, perform super cleaning.

P. 100 "Super Cleaning"

**Is the media wrinkled?**

If the media is wrinkled and comes loose from the platen, colors may be uneven or the printing quality may suffer.

P. 187 "Media Feed Is Not Smooth"

**Was printing paused partway through?**

When printing is paused, the coloring at the seam may be altered when printing resumes. Avoid pausing printing. With the factory default settings, printing pauses when an ink pouch runs out. Before you perform lengthy printing, check the amount of ink remaining in the ink pouches. Printing may also pause when data is not sent from the computer quickly enough. We recommend not performing any other tasks with the computer while printing is in progress.

**Is the printer installed in a level and stable location?**

Never install the machine in a location where it is tilted or where it may wobble or experience vibration. Also make sure that the print heads are not exposed to moving air. These factors may lead to dot-dropout or reduced printing quality.

**Is the media loaded correctly?**

If the media is not loaded correctly or the media feed is not smooth, printing may be adversely affected. Load the media correctly.

P. 187 "Media Feed Is Not Smooth"

**Are the operating parameters set to appropriate values?**

Depending on the settings for such menu items as [FULL WIDTH S] and [PERIODIC CL.], uneven colors may occur. If the settings have been changed, try restoring them to their default values.

P. 139 "Speeding Up Output for Narrow Media"







P. 140 "Preventing Soiling of the Media and Dot Drop-out"

**Are the settings for the [PRE-SET] menu item appropriate?**

If the settings selected with the [PRESET] menu item are not suitable for the type of media, output may be adversely affected. Choose settings optimized for the media you are using.

P. 120 "Using Presets"

## Cutting Is Misaligned or Skewed

<p><b>Is the media loaded correctly?</b></p>		<p>If the media is not loaded correctly or the media feed is not smooth, cutting may be adversely affected. Make sure the media is loaded and set up correctly.</p> <p>P. 187 "Media Feed Is Not Smooth"</p>
<p><b>Are the settings for the cutting conditions appropriate?</b></p>		<p>Misalignment or skewing may occur if the cutting speed is too fast or the blade force is too high. Try changing the cutting conditions. With media having a strong adhesive layer, the adhesive layer reattaches to itself immediately after cutting. However, if a cutting test shows that the peeling of the media and the blade traces on the backing paper are optimal, the media is being cut properly. Be careful not to make the blade force too high.</p> <p>P. 142 "Fine-tuning the Cutting Conditions"</p>
<p><b>Is the length of output too long?</b></p>		<p>For printing followed immediately by cutting in particular, the longer the page length (that is, the longer the distance the media is returned after printing), the greater the chance of misalignment occurring. It is a good idea to keep the size of each single page to the minimum necessary.</p>
<p><b>Are you using media that exhibits large expansion and contraction?</b></p>		<p>When you are performing printing followed immediately by cutting, misalignment occurs if the media expands or contracts. If this happens, try performing printing with crop marks, and then setting the base point and align points and performing cutting. This corrects for the expansion and contraction of the media.</p> <p>P. 63 "Printing and Cutting with Crop Marks"</p>
<p><b>Is [AUTO ENV. MATCH] set to "DISABLE?"</b></p>		<p>The printing and cutting positions may become misaligned due to the ambient temperature or humidity. Setting [AUTO ENV. MATCH] to "ENABLE" performs matching to the environment to correct for misalignment.</p> <p>P. 149 "Viewing the Automatic Environment Correction Function Settings"</p>
<p><b>Is the setting for the [CALIBRATION] menu item (under [CUTTING MENU]) correct?</b></p>		<p>When you are performing printing followed immediately by cutting, go to [CUTTING MENU] and set the [CALIBRATION] value to "0.00."</p> <p>P. 145 "Performing Distance Correction During Cutting"</p>
<p><b>Are the pinch rollers placed on the proper locations?</b></p>		<p>Be sure to place the pinch rollers on the grit rollers. If the pinch rollers are not placed on the proper locations, misalignment of the media may occur.</p> <p>P. 29 "Step 1 : Loading Roll Media (Setup of Media)" P. 74 "Loading Sheet Media (Setup of Media)"</p>

# A Media Jam Occurs!

## The Media Has Jammed

If an error message is displayed because the media has jammed, immediately correct the problem. Doing so may damage the print heads.

P. 200 "[MOTOR ERROR TURN POWER OFF]"

Is the media warped or wrinkled?

Many factors can cause warping or wrinkling. Refer to the following and correct the problem.

P. 187 "Media Feed Is Not Smooth"

Is the height of the print heads too low?

Try raising the print heads. Media may inevitably warp or wrinkle slightly, so adjust the height of the print heads to take this into account.

P. 135 "Adjusting Print Head Height to Match Media Thickness"

Are the grit rollers dirty?

Check to make sure the grit rollers are free of buildup of foreign material such as media scraps.

P. 82 "Cleaning"

Are the media clamps attached?

When you are performing printing, be sure to attach the media clamps.

Is the media loaded straight and securely?

Feeding is not smooth when the media is not straight or is tensioned unevenly on the left and right. Reload the media.

P. 29 "Step 1 : Loading Roll Media (Setup of Media)"  
P. 74 "Loading Sheet Media (Setup of Media)"

Is some other object coming into contact with the media?

Make sure that nothing touches the media.

P. 29 "Step 1 : Loading Roll Media (Setup of Media)"  
P. 74 "Loading Sheet Media (Setup of Media)"

Is the media too thick?

Media that is too thick may not only cause an unstable feed but may scrape the print heads, resulting in a malfunction. Never use such media.

# Media Feed Is Not Smooth

A variety of problems can occur if the media feeding is not smooth. This can cause such problems as poor printing quality, contact with the media by the print heads, misaligned positioning, and media jams. Take action as follows.

## Media Wrinkles or Shrinks

Is the media loaded and set up straight and securely?	⇒	Feeding is not smooth when the media is not straight or is tensioned unevenly on the left and right. Reload the media. P. 29 "Step 1 : Loading Roll Media (Setup of Media)" P. 74 "Loading Sheet Media (Setup of Media)"
Was loaded media allowed to stand for some time?	⇒	Media may shrink or wrinkle if it is heated for an extended time. When printing ends, switch off the sub power or remove the media.
Are the media clamps attached?	⇒	When you are performing printing, be sure to attach the media clamps.
Was the media loaded while the print heater was hot?	⇒	Loading media after the print heater has warmed up causes the temperature of the media to rise suddenly, which may cause the media to shrink or wrinkle during printing. Before loading media, switch off the sub power and allow the platen to cool. P. 123 "Settings for the Media Heating System"
Are the media heating system temperatures too high?	⇒	Set the temperatures to suitable values for the type of media. P. 123 "Settings for the Media Heating System"
Is the temperature of the room too low?	⇒	Use the machine in an environment with an ambient temperature of 20 to 32°C (68 to 90°F). If the machine is used at an ambient temperature of less than 20°C (68°F), then depending on the type or width of the media, wrinkling or temperature-caused unevenness may occur. If this happens, try lowering the temperature of the media heating system by about 2°C (36°F). To obtain stable printing results, however, use the machine in an environment with an ambient temperature of 20 to 32°C (68 to 90°F).
Is the humidity of the room too high?	⇒	Use the machine in an environment with a humidity of 35 to 80%RH (no condensation).
Is the media sagging?	⇒	If sagging media is used, it may come out wrinkled.

### Media Feeding Is Not Straight

<p><b>Is the media loaded and set up straight and securely?</b></p>	<p>→</p> <p>Feeding is not smooth when the media is not straight or is tensioned unevenly on the left and right. Reload the media.</p> <p>P. 29 "Step 1 : Loading Roll Media (Setup of Media)" P. 74 "Loading Sheet Media (Setup of Media)"</p>
---	---

### Media Feeding Is Not Smooth

<p><b>Is some other object coming into contact with the media or the shafts?</b></p>	<p>→</p> <p>Make sure the media and the shafts do not touch anything else. This may affect output, even when the feed appears to be smooth.</p> <p>P. 29 "Step 1 : Loading Roll Media (Setup of Media)" P. 74 "Loading Sheet Media (Setup of Media)"</p>
<p><b>Is the media too thick?</b></p>	<p>→</p> <p>Media that is too thick may not only cause an unstable feed but may scrape the print heads, resulting in a malfunction. Never use such media.</p>
<p><b>Are the grit rollers dirty?</b></p>	<p>→</p> <p>Check to make sure the grit rollers are free of buildup of foreign material such as media scraps.</p> <p>P. 82 "Cleaning"</p>

# The Print Heads Do Not Move

If the print-head carriage stops over the platen, take action immediately to prevent the heads from drying out.

## What to Do First

Switch the sub power off and then back on again. If the media is jammed, also remove the media. If the print heads move to the home position (inside the right cover), it means the operation has ended successfully.

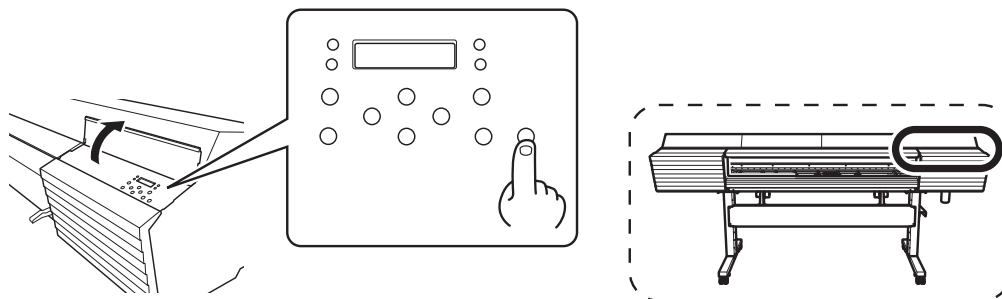

---

## If the Heads Still Do Not Move

---

Try switching off the main power, then switching on the main power again, followed by the sub power.

## If the Heads Still Do Not Move

If the heads still do not move, carry out the following emergency response measure, and then contact your authorized Roland DG Corporation dealer.

### Procedure

---

- 1 Switch off the main power, and then open the front cover.
- 2 Open the right cover.

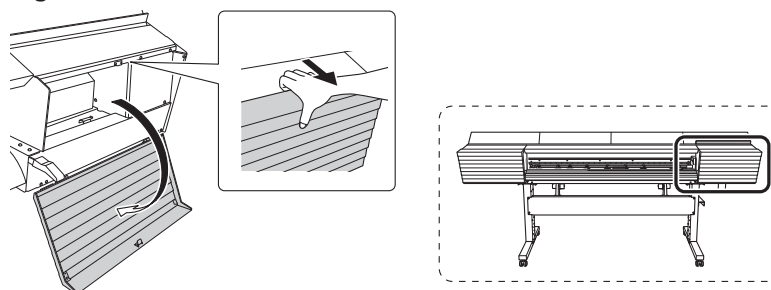



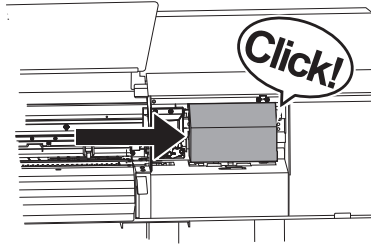





- 3 Gently move the print-head carriage to the home position by hand.**  
Stopping at the place where the audible click is heard locks the print-head carriage in place.





- 4 Gently apply pressure from the right side to make sure the print-head carriage does not move to the left.**  
If the print-head carriage moves to the left, again move it slowly by applying pressure from the left side and make sure it locks in place.



# Other Problems

## The Printer Unit Does Not Run

<p><b>Is the power switched on?</b></p>		<p>Switch on the printer's main power, and then press the sub power switch and make sure the sub power switch lights.</p> <p>P. 24 "Turning the Power On"</p>
<p><b>Is [SETUP] lit?</b></p>		<p>Output is not performed when [SETUP] is not lit. Lower the loading lever.</p> <p>P. 56 "Step 6 : Starting Output"</p>
<p><b>Are any covers open?</b></p>		<p>Close the front, left, and right covers.</p>
<p><b>Is the top menu displayed?</b></p>		<p><b>Top menu</b></p> <div data-bbox="715 642 1055 721" style="border: 1px solid black; padding: 2px; display: inline-block;"> <p>W1100mm</p> </div> <p>If the top menu isn't displayed, output doesn't start even when data is sent from the computer. To go to the top menu, press [MENU].</p> <p>P. 56 "Step 6 : Starting Output"</p>
<p><b>Is [PAUSE] lit?</b></p>		<p>When [PAUSE] is lit, operation is paused. To resume, press [PAUSE]. [PAUSE] turns off and output resumes.</p> <p>P. 79 "Pausing and Canceling Output"</p>
<p><b>Is a message displayed on the screen?</b></p>		<p>P. 195 "A Message Appears" P. 197 "An Error Message Appears"</p>
<p><b>Is the cable connected?</b></p>		<p>Connect the cable securely.</p> <p>Setup Guide</p>
<p><b>Is the network routing appropriate?</b></p>		<p>Check whether or not the network routing is appropriate. Try connecting the computer and the machine to the same hub or connecting them directly using a crossover cable. If this makes it possible to perform output, it means the problem may be in the network itself.</p>
<p><b>Are the network settings correct?</b></p>		<p>If the cable connections are secure and no problem is found in the network itself, make sure that the IP address and other such settings are appropriate. The settings on both the machine and the computer must be appropriate. Redo the settings while checking to ensure that the IP address does not conflict with the IP address for another device on the network, that the port setting for the software RIP specifies the IP address set on the machine, that the settings have no typing errors, and for other such problems.</p> <p>Setup Guide P. 172 "Viewing System Information"</p>

<p><b>Did the software RIP end abnormally?</b></p>		<p>Make sure the software RIP is running correctly, and then switch the sub power switch off and back on.</p> <p>Roland VersaWorks Dual Installation Guide</p>
<p><b>Has ink run out?</b></p>		<div data-bbox="697 348 1038 427" style="border: 1px solid black; padding: 5px; text-align: center;"> <p>1 2 3 4 5 6 7 8</p> </div> <p>When the screen shown in the figure is displayed, output data cannot be accepted. If the screen shown in the figure is displayed during printing, the behavior of the machine depends on the [EMPTY MODE] setting.</p> <ul style="list-style-type: none"> <li>• When "STOP" is selected: This pauses printing operation.</li> <li>• When "CONT." is selected: A warning beep sounds, and printing continues until the machine has finished printing the data it has accepted. In this case, it is also possible to press [PAUSE] and pause printing.</li> </ul> <p>In both cases, the error can be resolved by replacing the ink pouch with a new one. If there is data that has not yet been output remaining in the machine, output resumes. If there is unsent data in the computer, output resumes when the data is resent.</p> <p>P. 70 "Ink Pouch Replacement" P. 164 "Determining What Happens When Ink Runs Out"</p>

## The Media Heating System Doesn't Warm Up

<p><b>Is the media loaded?</b></p>		<p>The media heating system does not warm up to the set temperature when [SETUP] is off (by default). Load the media and wait for the machine to warm up.</p> <p>P. 123 "Settings for the Media Heating System"</p>
<p><b>Is the temperature of the room too low?</b></p>		<p>Use the machine in an environment where the temperature is 20 to 32°C (68 to 90°F).</p>

## Cannot Cut Off the Media.

<p><b>Is the separating knife installed?</b></p>		<p>If the separating knife is not installed, you cannot cut off the media.</p> <p>P. 114 "Replacing the Separating Knife"</p>
--	---	---

**Is the cut rail installed?**



If the cut rail is not installed, you cannot cut off the media. If the cut rail is not installed, remove the left cover, and then install the cut rail according to the figure shown below. After installing the cut rail, be sure to attach the left cover.

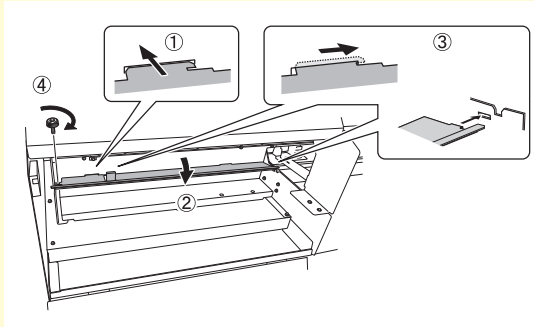

**It Is Not Possible to Check the Amount of Discharged Fluid in the Drain Bottle**

**Is ink splattered around the inside of the drain bottle?**



If ink is splattered around the inside of the drain bottle, it may not be possible to check how much discharged fluid the bottle contains.

P. 85 "If It Is Not Possible to Check the Amount of Discharged Fluid in the Drain Bottle"

**Printer Cannot Be Operated from Mobile Panel**

☞ P. 159 "Important Notes on Using Mobile Panel"

**Is the printer's operation panel in use?**



When you are using the printer's operation panel, you cannot perform operations from Mobile Panel. Stop performing operations from the operation panel, and then press [MENU] on the operation panel.

P. 159 "Using Mobile Panel"

**Is printer-side Bluetooth communication turned on?**



The printer's Bluetooth communication is turned off in the default settings. When using Mobile Panel, use the printer's operation panel to turn on Bluetooth communication.

P. 169 "Turning on Bluetooth Communication"

**Is Mobile Panel connected to a different printer?**



You can only connect to one printer from a mobile terminal on which Mobile Panel has been installed. You can register multiple printers on Mobile Panel, but you cannot connect to multiple printers at the same time. If you want to operate multiple printers, use Mobile Panel to select the printer that you will connect to.

**Is the printer-side Bluetooth communication normal?**



The state of the printer's Bluetooth communication is displayed on the screen.

- **ENABLE:** The printer's Bluetooth communication is on, and the printer is waiting for a connection to be established. If you cannot operate the printer from Mobile Panel, there is a problem with the connection environment. Check the causes of other problems.
- **ENABLE\*:** The printer's Bluetooth communication is on, and the printer is connected to Mobile Panel.
- **DISABLE:** The printer's Bluetooth communication is off.
- **ERROR:** An error has occurred in the printer's Bluetooth communication. Purchase them from your authorized Roland DG Corporation dealer.

\* However, when the above screens are displayed, you cannot perform operations from Mobile Panel.

P. 159 "Using Mobile Panel"  
P. 172 "Viewing System Information"

**Is the distance between the printer and the mobile terminal too far?**



The valid range for Bluetooth communication is approximately 10 m. Bring the printer and the mobile terminal on which Mobile Panel has been installed as close together as possible.

**Are there any obstacles between the printer and the mobile terminal?**



If obstacles (such as people, metal, and walls) are present between the printer and the mobile terminal, Bluetooth communication may be unstable. Use Mobile Panel from a location where there are no obstacles between the printer and the mobile terminal.

**Is the mobile terminal's Bluetooth function turned on?**



Check the Bluetooth status of the mobile terminal on which Mobile Panel has been installed. For the usage method of your mobile terminal, refer to its user's manual.

**Is there a wireless LAN unit or anything else in the vicinity that is causing Bluetooth communication to be unstable?**



The Bluetooth communication status may become unstable if:

- A wireless LAN is in place in the location.
- The devices are in the vicinity of a microwave that is in use.
- Other electromagnetic waves are generated in the location.

# A Message Appears

These are the main messages that appear on the machine's display to prompt correct operation. They do not indicate any error. Follow the prompts and take action accordingly.

Message	Situation/cause	Action
[1 ■ 2 ■ 3 ■ 4 ■ 5 ■ 6 ■ 7 ■ 8 ■]	Only a small amount of ink remains.	Replace the ink pouch indicated by the flashing number with a new pouch.
[CLOSE COVER (FRONT COVER/COVER L/COVER R)]	The front, left, or right cover is open. For safety, the carriage does not operate while a cover is open.	Close the front, left, or right cover.
[PRESS THE ENTER KEY TO CONTINUE]	The cover was closed after [CLOSE COVER (FRONT COVER/COVER L/COVER R)] was displayed.	Press [ENTER]. The machine will continue its operation.
[SHEET NOT LOADED PRESS SETUP KEY]	This message appears when an attempt to perform a printing test was made while no media was loaded.	Load media.
[CLOSE SLOT COVER]	This message appears if the ink slot cover is open when output starts.	Close the ink slot cover.
[END OF THE SHEET]	The trailing edge of the media was detected during operation.	Press any key on the operation panel to clear the message. Load new media.
[EMPTY DRAIN BOTTLE]	This message appears when a certain amount of discharged fluid collects in the drain bottle.	Discard the discharged fluid in the bottle. ⇨ P. 83 "When "EMPTY DRAIN BOTTLE" Is Displayed"
[INSTALL DRAIN BOTTLE]	Check whether the drain bottle is installed correctly.	Install the drain bottle, and then press [ENTER]. ⇨ P. 117 "Disposing of Discharged Fluid"
[NOW HEATING... NOW PROCESSING..]	The media heating system did not reach the set temperature. Wait until the set temperature is reached.	Printing starts when [HEATER] lights. You can stop output by holding down [PAUSE] for one second or longer while this is displayed. Pressing [PAUSE] makes printing start immediately without waiting to reach the preset temperature.
[REMOVE MEDIA CLAMPS]	This message appears if the media clamps are attached when you try to cut off the media.	Open the front cover, remove the left and right media clamps, and then press [ENTER].
[TIME FOR MAINTENANCE]	It is time to perform manual cleaning.	After verifying the message, press [ENTER], and then perform manual cleaning. ⇨ P. 90 "Manual Cleaning"
[TIME FOR WIPER REPLACE]	It is time to replace the wipers.	After verifying the message, press [ENTER], and then replace the wiper. ⇨ P. 104 "Replacing the Wiper"
[SET CL-LIQUID FOR WIPER]	No TR cleaning liquid pouch has been inserted.	After verifying the message, press [ENTER]. No TR cleaning liquid pouch has been inserted. If you have forgotten to insert the TR cleaning liquid pouch, insert it. ⇨ P. 72 "TR Cleaning Liquid Pouch Replacement"

## A Message Appears

[CHANGE CL-LIQ-UID FOR WIPER]	The TR cleaning liquid pouch is empty.	After verifying the message, press [ENTER]. The TR cleaning liquid pouch is empty. Replace it with a new wiper cleaning liquid pouch. ☞ P. 72 "TR Cleaning Liquid Pouch Replacement"
[FILL CLEANING LIQUID]	The wiper tray was not full with TR cleaning liquid when the sub power was turned on.	After verifying the message, press [ENTER]. The wiper tray is filled with TR cleaning liquid.
[TIME FOR TRAY CLEANING]	It is time to clean the wiper tray.	After verifying the message, press [ENTER]. Clean the wiper tray, and then replace the tray pads. ☞ P. 107 "Cleaning the Wiper Tray and Replacing the Tray Pads"
[CLOSE DRAIN VALVE]	The drain valve was open when the sub power was turned on.	Open the right cover, and then close the drain valve.
[HEAD PROTECTION ACTIVATED]	The ink in use may not be a product specified by Roland DG Corporation.	To clear the message, press [ENTER]. To obtain optimal performance, we recommend that you use ink specified by Roland DG Corporation. To purchase ink, contact your authorized Roland DG Corporation dealer.
[SOME MID. PINCHS NOT SET RIGHT]	The middle pinch rollers have not been set in place.	After verifying the message, press [ENTER]. Raise the loading lever, and then perform the operations again from P. 34 "4. Secure the media in place." You can continue work without setting the middle pinch rollers in place, but note that doing so may lead to decreased output quality.

# An Error Message Appears

This section describes the error messages that may appear on the machine's display, and how to take action to remedy the problem. If the action described here does not correct the problem or if an error message not described here appears, contact your authorized Roland DG Corporation dealer.

Message	Situation/error cause	Action
[ALIGN POINT POSITION INVALID]	An attempt was made to set an align point at a location where the setting cannot be made.	No align point can be set such that the angle between the base point and the align point is too large. Reload the media correctly, so that the angle is minimized, and then set the base point and the align points again to match the crop marks. ☞ P. 64 "How to Print and Cut with Crop Marks"
[OPTION DRYER IS NOT CONNECTED]	When [OPTION DRYER] is set to "ENABLE" with no auxiliary drying unit connected to the printer.	Switch the sub power and main power off, and then connect the optional dryer to the printer.
[HEATING TIME-OUT CONTINUE?]	The media heating system did not reach the set temperature. This occurs because the temperature of the location where the machine is installed is too low.	We recommend raising the temperature of the location where the machine is installed. To continue waiting for the temperature of the media heating system to rise, press [ENTER]. To start printing immediately, press [PAUSE].
[TEMPERATURE IS TOO LOW **°C]	The temperature of the location where the machine is installed has fallen below the ambient temperature at which the machine can operate.	Operation cannot be continued. Turn off the sub power. The displayed temperature is the current ambient temperature of the installation location. Bring the installed location to a temperature at which operation is possible (20 to 32°C [68 to 90°F]), allow the machine to come to room temperature, and then turn on the power.
[TEMPERATURE IS TOO HIGH **°C]	The temperature of the location where the machine is installed has risen above the ambient temperature at which the machine can operate.	Operation cannot be continued. Turn off the sub power. The displayed temperature is the current ambient temperature of the installation location. Bring the installed location to a temperature at which operation is possible (20 to 32°C [68 to 90°F]), allow the machine to come to room temperature, and then turn on the power.
[CROPMARK ERROR NOT FOUND]	Automatic detection of crop marks could not be accomplished.	Load the media at the correct position and perform detection of crop marks again. If repeating automatic crop-mark detection results in an error again, perform manual crop-mark detection. Depending on the media, it may not be possible to detect crop marks automatically. ☞ P. 64 "How to Print and Cut with Crop Marks" ☞ P. 66 "Automatic Detection of Crop Marks Fails" ☞ P. 152 "Aligning Positions Manually"

Message	Situation/error cause	Action
[CAN'T PRINT CROP CONTINUE?]	The size of the data including the crop marks is larger than the printing area of the loaded media.	To continue performing output without correcting this, press [ENTER]. At this time, the crop marks and the portion extending beyond the printing area are not output. To stop output, stop sending data from the computer, and then raise the loading lever. Make the printing area wider, for example, by replacing the media with a larger piece of media, and then send the data again.
	The size of the data being output is too small.	Make the horizontal-direction (scan-direction) size of the data at least 65 mm (2.6 in.). To continue performing output without correcting this, press [ENTER]. At this time, the data is output without printing the crop marks. To stop output, stop sending data from the computer, and then raise the loading lever. Change the size of the data, and then send the data again. There is no limitation on the size of the data in the media-feed direction.
[SHEET TOO SMALL CONTINUE?]	The size of the data is larger than the printing area of the loaded media	To continue performing output without correcting this, press [ENTER]. At this time, the portion extending beyond the printing area is not output. To stop output, stop sending data from the computer, and then raise the loading lever. Make the printing area wider, for example, by replacing the media with a larger piece of media, and then send the data again.
[DATA ERROR CANCELING...]	Output was stopped because a problem was found in the received data.	Operation cannot be continued. Check for a problem with the connector cable or the computer, and then redo the operations from the step of loading the media.
[SHEET SET ERROR SET AGAIN]	The loading lever was lowered while no media was loaded	Raise the loading lever, place media at the correct location, then lower the lever again. ⇨ P. 29 "Step 1 : Loading Roll Media (Setup of Media)" ⇨ P. 74 "Loading Sheet Media (Setup of Media)"
	[EDGE DETECTION] is set to "ENABLE," but transparent media was loaded.	Raise the loading lever, set the [EDGE DETECTION] menu item to "DISABLE," and then reload the media. ⇨ P. 136 "Using Transparent Media"
	The loaded media is too small	Press any button to clear the error. Replace the media with media of a usable size.
[PINCHROLL ERROR LOWER PINCHROLL]	This message appears when the loading lever was raised during initialization or after the media was loaded.	Press any key to clear the error. Alternatively, the error is cleared automatically after a short wait. Never move the loading lever while output is in progress.
[PINCHROLL ERROR INVALID LEFT(RIGHT)POS]	The left (right) pinch roller is positioned at a location where it cannot pinch the media.	Raise the loading lever and move the pinch roller to the correct location. ⇨ P. 29 "Step 1 : Loading Roll Media (Setup of Media)" ⇨ P. 74 "Loading Sheet Media (Setup of Media)"

Message	Situation/error cause	Action
[PINCHROLL ERROR *** FROM RIGHT]	The middle pinch rollers are positioned at locations where they cannot pinch the media.	Raise the loading lever and move the middle pinch rollers to the correct location. ☞ P. 29 "Step 1 : Loading Roll Media (Setup of Media)" ☞ P. 74 "Loading Sheet Media (Setup of Media)"
	There are too many middle pinch rollers installed.	Raise the loading lever, and then remove all middle pinch rollers that are not positioned above grit rollers. The number of middle pinch rollers used varies according to the width of the loaded media. ☞ P. 29 "Step 1 : Loading Roll Media (Setup of Media)" ☞ P. 74 "Loading Sheet Media (Setup of Media)"
[WRONG CARTRIDGE]	Has an ink pouch that cannot be used been installed?	Remove the pouch tray to clear the error. Use an ink pouch of the specified type.
[CANCELED FOR PUMP PROTECTION]	The printer made an emergency stop because a state in which ink was not present continued for 10 minutes or longer while cleaning (normal, medium, powerful, damper, super, or automatic cleaning while sub power was switched off) was in progress or during the first ink filling procedure for the machine.	Operation cannot be continued. Turn off the sub power. After turning the power off, contact the your authorized Roland DG Corporation dealer.
[AVOIDING DRY-UP TURN POWER OFF]	The print heads were forced to the home position to prevent them from drying out.	Operation cannot be continued. Switch the sub power off, and then back on.
[SET HEAD HEIGHT TO ****]	Is the height of the print heads lower than the height specified in the software RIP?	This warning indicates that the height of the print heads is too low for the media thickness specified in the software RIP. The print heads move to a location where you can operate the height-adjustment lever. Adjust to the displayed height, and then press [ENTER]. ☞ P. 135 "Adjusting Print Head Height to Match Media Thickness"

## An Error Message Appears

Message	Situation/error cause	Action
[MOTOR ERROR TURN POWER OFF]	A motor error occurred.	Operation cannot be continued. Turn off the sub power. Next, eliminate the cause of the error, then immediately switch on the sub power. If the machine is allowed to stand with the error uncorrected, the print heads may dry out and become damaged. This error may be caused by such factors as a mistake in loading the media, a media jam, or an operation that pulls the media with excessive force.
	The media has jammed.	Carefully remove the jammed media. The print heads may also be damaged. Perform head cleaning, and then perform a printing test and check the results. ⇨ P. 53 "Step 5 : Printing Tests and Normal cleaning"
	Has the media been pulled with excessive force?	Excessive tension was applied to the media, and additional action is necessary to recover from this state. First, raise the loading lever and adjust the media to create a small amount of slack, and then switch on the sub power.
[SERVICE CALL ****]	An unrecoverable error occurred or part replacement that must be performed by a service technician is required.	Note the number displayed, and then switch off the sub power. After you switch off the power, inform your authorized Roland DG Corporation dealer of the number that appeared on the display.
[CLEANING ERROR]	The printer made an emergency stop for one of the following reasons. <ul style="list-style-type: none"> <li>• Ink ran out during "damper cleaning."</li> <li>• A pouch tray was pulled out during "damper cleaning."</li> <li>• A pouch tray was pulled out during the first ink filling procedure for the machine.</li> </ul>	Operation cannot be continued. Switch the sub power off by holding down the switch for one second or longer, and then switch the sub power back on again. Afterward, redo the "damper cleaning" or ink filling from the start. However, if the printer stopped part-way through "damper cleaning," first execute the "SUPER CL." menu item, and then redo the "damper cleaning." ⇨ P. 100 "Super Cleaning"

# Chapter 7 Appendix

---

Printing Area .....	202
Maximum Area.....	202
Maximum Area When Using Crop Marks .....	202
The Media-Cutoff Location During Continuous Printing .....	203
About the Blade .....	204
Locations of the Power Rating and Serial Number Labels .....	205
Specifications.....	206

# Printing Area

## Maximum Area

The printing or cutting area along the horizontal plane (the direction in which the carriages move) is determined by the position of the pinch rollers.

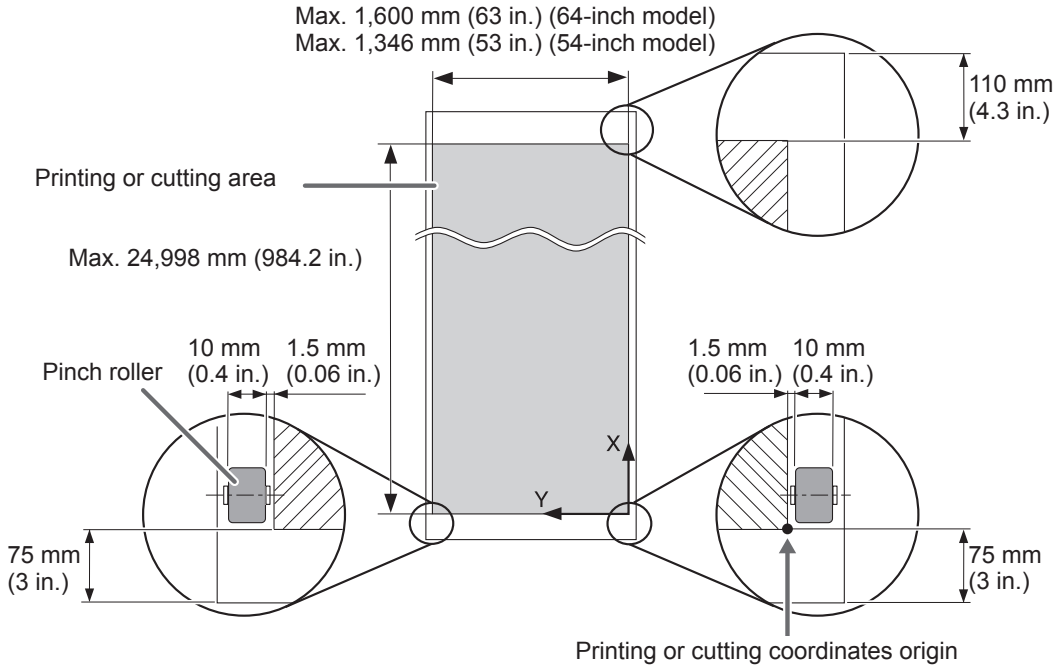

## Maximum Area When Using Crop Marks

When crop marks are used, the printing area is reduced from the maximum area by an amount equal to the crop marks.

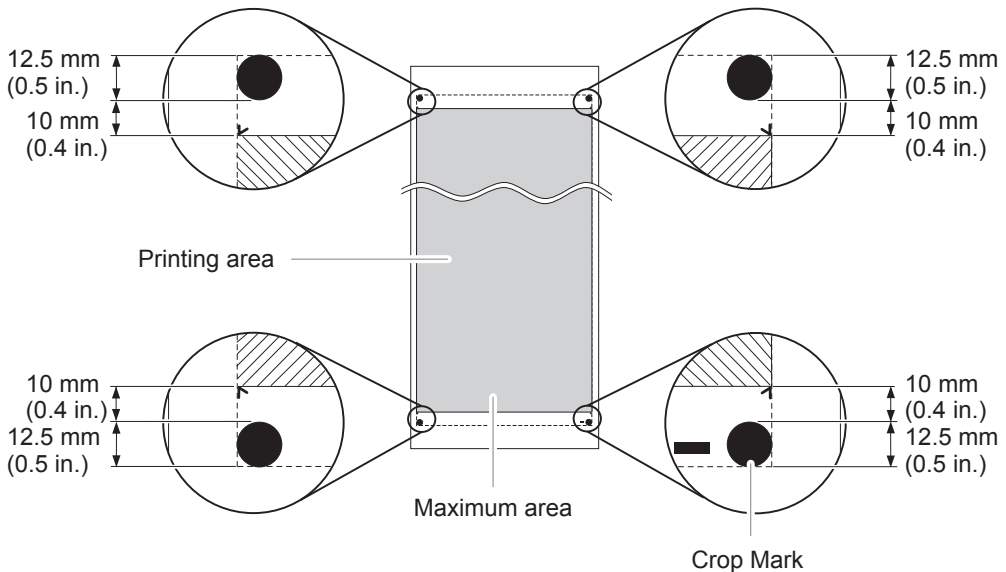

## The Media-Cutoff Location During Continuous Printing

When a media-cutoff command is sent from the computer, the cutoff location on the media is as shown in the figure below.

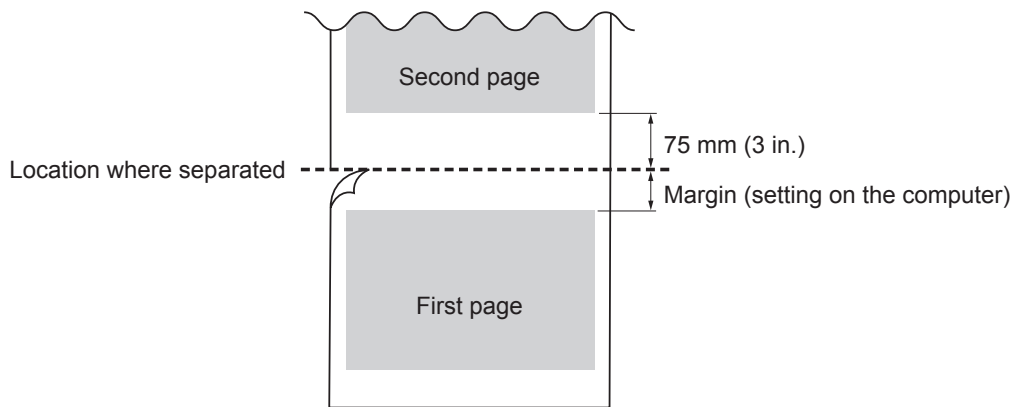

# About the Blade

The cutting conditions and the service life of the blade change according to the media and the operating environment, even when you're using identical blades. The service life also differs according to the type of blade. A rough guide is shown below.

Blade	Media	Blade force	Amount of blade offset	Blade life* (general guide)
ZEC-U1005	General signage vinyl	50 to 150 gf	0.25 mm (0.01 in.)	8,000 m (26,246.4 ft.)
ZEC-U5025	General signage vinyl	30 to 100 gf	0.25 mm (0.01 in.)	4,000 m (26,246.4 ft.)
	Fluorescent vinyl	120 to 200 gf	0.25 mm (0.01 in.)	4,000 m (26,246.4 ft.)
	Reflective vinyl	100 to 200 gf	0.25 mm (0.01 in.)	4,000 m (26,246.4 ft.)

When uncut areas remain even when the blade force is increased to a value that is higher by 50 to 60 gf than the values shown in this chart, then replace the blade.

\* The values for "Blade life" are estimates for when an identical type of media is used.

# Locations of the Power Rating and Serial Number Labels

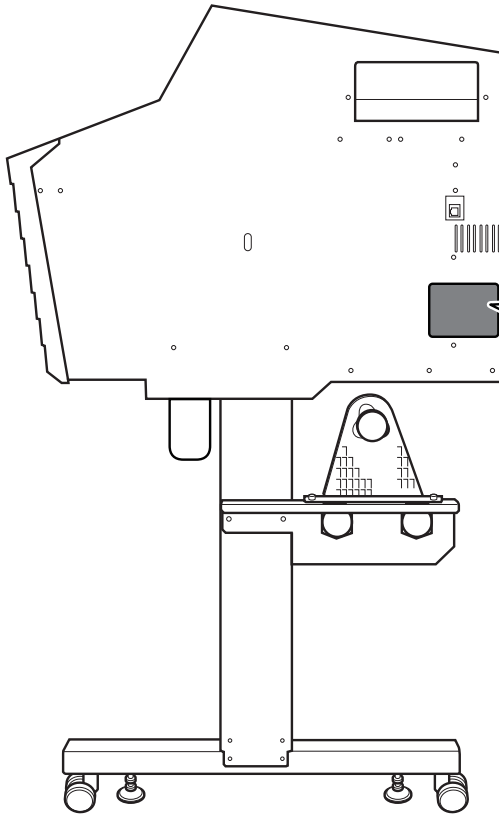

**Serial number**

This is required when you seek maintenance, servicing, or support. Never peel off the label.

**Power ratings**

Use an electrical outlet that meets the requirements for voltage, frequency, and amperage given here.

Right side

# Specifications

		VG-640	VG-540
<b>Printing technology</b>		Piezoelectric inkjet	
<b>Media</b>	<b>Width</b>	210 to 1,625 mm (8.3 to 64 in.)	210 to 1,371 mm (8.3 to 54 in.)
	<b>Thickness</b>	Max. 1.0 mm (39 mil) with liner, for printing Max. 0.4 mm (16 mil) with liner and 0.22 mm (9 mil) without liner, for cutting	
	<b>Roll outer diameter</b>	Max. 210 mm (8.3 in.)	
	<b>Roll weight</b>	Max. 40 kg (88 lb.)	Max. 30 kg (66 lb.)
	<b>Core diameter (*1)</b>	76.2 mm (3 in.) or 50.8 mm (2 in.)	
<b>Printing/cutting width (*2)</b>		Max. 1,600 mm (63 in.)	Max. 1,346 mm (53 in.)
<b>Ink</b>	<b>Type</b>	TrueVIS INK 500 cc pouch	
	<b>Colors</b>	Eight colors (cyan, magenta, yellow, black, light cyan, light magenta, light black, and white) Seven colors (cyan, magenta, yellow, black, light cyan, light magenta, and light black) Four colors (cyan, magenta, yellow, black)	
<b>Printing resolution (dots per inch)</b>		Max. 900 dpi	
<b>Cutting speed</b>		10 to 300 mm/s (0.4 to 11.8 in/s)	
<b>Blade force(*3)</b>		30 to 500 gf	
<b>Blade</b>	<b>Type</b>	Roland CAMM-1 series blade	
	<b>Blade offset</b>	0.000 to 1.500 mm (0.0 to 59.1 mil)	
<b>Software resolution (when cutting)</b>		0.025 mm/step (0.98 mil/step)	
<b>Distance accuracy (when printing) (*4) (*5)</b>		Error of less than $\pm 0.3$ % of distance traveled or $\pm 0.3$ mm ( $\pm 11.8$ mil), whichever is greater	
<b>Distance accuracy (when cutting) (*4)</b>		Error of less than $\pm 0.4$ % of distance traveled or $\pm 0.3$ mm ( $\pm 11.8$ mil), whichever is greater When distance correction has been performed (when the setting for [CUTTING MENU] - [CALIBRATION] has been made): Error of less than $\pm 0.2$ % of distance traveled or $\pm 0.1$ mm ( $\pm 3.9$ mil), whichever is greater	
<b>Repeatability (when cutting) (*4) (*6)</b>		$\pm 0.1$ mm ( $\pm 3.9$ mil) or less	
<b>Alignment accuracy for printing and cutting (*4) (*7)</b>		$\pm 0.5$ mm ( $\pm 19.7$ mil) or less	
<b>Alignment accuracy for printing and cutting when reloading media (*4) (*8)</b>		Error of less than $\pm 0.5$ % of distance traveled by media or $\pm 3$ mm ( $\pm 0.2$ in.), whichever is greater	
<b>Media heating system (*9)</b>		Print heater set temperature: 30 to 45°C (86 to 112°F) Dryer set temperature: 30 to 50°C (86 to 122°F)	
<b>Connectivity</b>		Ethernet (100BASE-TX/1000BASE-T, automatic switching)	
<b>Power-saving function</b>		Automatic sleep feature	
<b>Power requirements</b>		AC 100 to 120 V $\pm 10\%$ , 9.8 A, 50/60 Hz or AC 220 to 240 V $\pm 10\%$ , 5.2 A, 50/60 Hz	AC 100 to 120 V $\pm 10\%$ , 7.9 A, 50/60 Hz or AC 220 to 240 V $\pm 10\%$ , 4.1 A, 50/60 Hz
<b>Power consumption</b>	<b>During operation</b>	Approx. 1,270 W	Approx. 1,030 W
	<b>Sleep mode</b>	Eight colors and seven colors: 43 W Four colors: 48 W	
<b>Acoustic noise level</b>	<b>During operation</b>	63 dB (A) or less	
	<b>During standby</b>	53 dB (A) or less	
<b>Dimensions (with stand)</b>		2,945 (W) x 730 (D) x 1,310 (H) mm (116 [W] x 28.8 [D] x 51.6 [H] in.)	2,685 (W) x 730 (D) x 1,310 (H) mm (105.8 [W] x 28.8 [D] x 51.6 [H] in.)
<b>Weight (with stand)</b>		205 kg (451.9lb.)	191 kg (421lb.)

<b>Environment</b>	<b>Power on (*10)</b>	Temperature: 20 to 32°C (68 to 90°F), humidity: 35 to 80 % RH (no condensation)
	<b>Power off</b>	Temperature: 5 to 40°C (41 to 104°F), humidity: 20 to 80 % RH (no condensation)
<b>Included items</b>		Dedicated stands, power cord, media clamps, media holders, replacement blade for separating knife, User's Manual, etc.

\*1

The media holders of this machine are designed to be used exclusively with media that has a paper tube (core) with an inner diameter of 3 inches. To use 2-inch media, the optional media flanges are required.

\*2

The length of printing or cutting is subject to the limitations of the program.

\*3

- 500 gf is the maximum instantaneous blade force.
- The blade force must be adjusted according to details such as the media thickness.

\*4

- Media type: Media specified by Roland DG Corp.
- Temperature: 25°C (77°F), humidity: 50%
- Roll media must be loaded correctly.
- Applicable when all pinch rollers that can be used with the media width are used.
- Side margins: 25 mm (1.0 in.) or more for both the left and right margins
- Excluding expansion/contraction of the media
- Not guaranteed when the print heater or dryer is used.
- Assumes all correction and adjustment functions of the machine have been used properly.

\*5

- Print travel: 1 m (39.4 in.)

\*6

- [PREFEED] menu item must be set to "ENABLE."
- Range for assured repetition accuracy
- For media with a width exceeding 610 mm (24.0 in.): Length 4,000 mm (157.5 in.)
- For media with a width of 610 mm (24.0 in.) or less: Length 8,000 mm (315.0 in.)

\*7

- Provided that the media feed length is 3,000 mm (118.1 in.) or less.
- Excludes the effects of slanted movement and of expansion and contraction of the media.

\*8

- Data size:  
64-inch model: 1,000 mm (39.4 in.) in the media-feed direction, 1,600 mm (63.0 in.) in the carriage-movement direction  
54-inch model: 1,000 mm (39.4 in.) in the media-feed direction, 1,346 mm (53.0 in.) in the carriage-movement direction
- No lamination
- Automatic detection of crop marks at 4 points when media is reloaded
- During cutting, [PREFEED] menu item must be set to "ENABLE."
- Excluding possible shift caused by expansion/contraction of the media and/or by reloading the media.

\*9

- Warm-up is required after the power is turned on. This may require 5 to 20 minutes, depending on the operating environment.
- Depending on the ambient temperature and the media width, the set temperature may not be reached.

\*10

- Operating environment

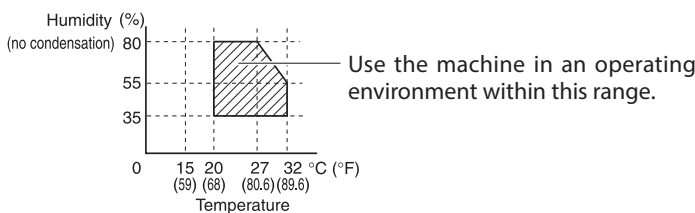

# MEMO

---

A series of horizontal dotted lines for writing.