

TrueVIS VF2-640

User's Manual

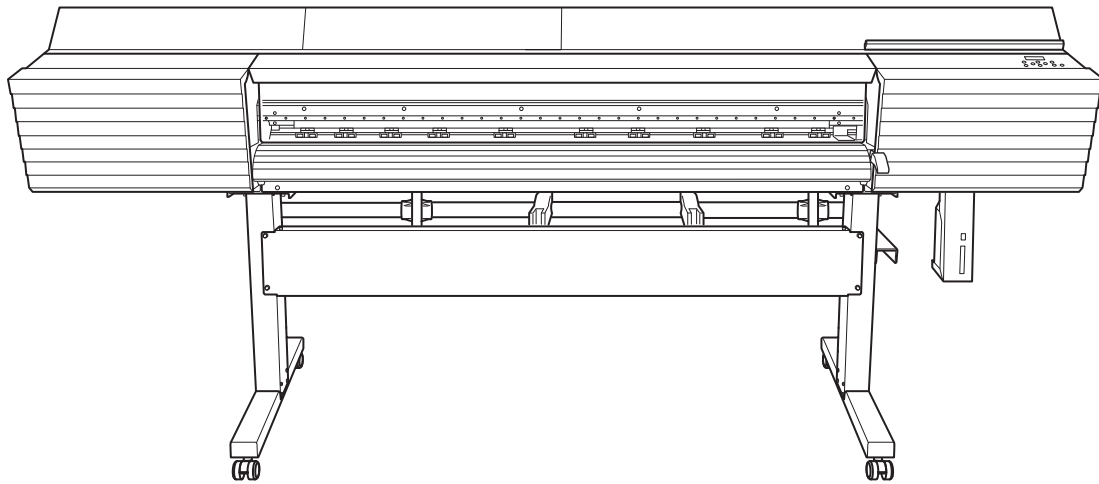

Thank you very much for purchasing this product.

- To ensure correct and safe usage with a full understanding of this product's performance, please be sure to read through this manual completely and store it in a safe location.
- Unauthorized copying or transferal, in whole or in part, of this manual is prohibited.
- The specifications of this product and the contents of this operation manual are subject to change without notice.
- The operation manual and the product have been prepared and tested as much as possible. If you find any misprints or errors, please inform us.
- Roland DG Corporation assumes no responsibility for any direct or indirect loss or damage that may occur through use of this product, regardless of any failure to perform on the part of this product.
- Roland DG Corporation assumes no responsibility for any direct or indirect loss or damage that may occur with respect to any article made using this product.

FA02552/R2-210405

<http://www.rolanddg.com/>

Copyright © 2020 - 2021 Roland DG Corporation

Roland DG Corporation

Contents

Basic Handling Methods	7
Basic Information	8
Part Names and Functions	9
Printer Unit	9
Operation Panel	14
Display Screen	15
About the Media Used	16
Types of Media	16
Conditions for Usable Media	17
Menu List	18
Main Menu	18
Function Menu	21
Language and Unit Menu	22
Basic Operations	23
Power Supply Operations	24
Turning the Power On	24
Turning the Power Off	25
Precautions When Operating the Power Supply	26
Sleep Mode (Power-saving Feature)	27
Setup of Media	28
Setup of Roll Media	28
Setup of Sheet Media	35
Separating the Media	39
What to Do First after Installation	40
Accurately Adjusting the Misalignment of the Ink Landing Position	40
Checking before Output	42
LAN (Local Area Network) Settings	42
Preventing Sedimentation in Inks	43
Pausing and Canceling Output	44
Pausing and Resuming Output	44
Canceling Output	45
Ink Pouch/TR2 Cleaning Liquid Pouch Replacement	46
Out-of-ink Warnings	46
Out-of-TR2-cleaning-liquid Warnings	47
Ink Pouch Replacement	48
TR2 Cleaning Liquid Pouch Replacement	50
Output Method	52
Printing Method	53
Preparations before Printing Output	54
Printing Tests and Normal Cleaning	54
Printing Output	57
Step 1: Batch Settings for Printing	57
Step 2: Starting Output	66
Optimizing Quality and Efficiency	68
Optimizing the Output Quality	69
Using the Correction Functions	70
Adjusting the Misalignment of the Ink Landing Position	70
Accurately Adjusting the Misalignment of the Ink Landing Position	72
Reducing Horizontal Bands (Feed Correction Function)	75

Configuring Settings to Match the Properties of the Media	77
Changing the Print Head Height.....	77
Using Transparent Media	79
Using Hard-to-Dry Media	82
Using Media That Wrinkles Easily/Does Not Move Smoothly	83
Using Sticky Media.....	84
Preventing Ink Discharge Issues.....	85
Preventing Soiling of the Media, Dot Drop-out, and Dot Displacement	85
Adjusting the Ink-drying Method	86
What Is the Media Heating System?.....	86
Setting the Print Heater Temperature	87
Setting the Dryer Temperature.....	88
Hints and Tips for Temperature Control	89
Setting the Temperature during Preheating.....	90
Drying the Trailing Edge of the Printing Area on the Dryer	91
Setting the Drying Time after Printing	92
Switching Off the Print Heater and Dryer Together	93
Using an Auxiliary Drying Unit.....	94
Using a Blower-fan Unit	95
Optimizing Work Efficiency	96
Using Presets	97
Saving the Current Settings in Presets	97
Loading and Outputting a Preset.....	99
Adjusting the Output-start Location.....	100
Setting the Base Point	100
Reducing Output Time	102
Speeding Up Output for Narrow Media.....	102
Adjusting the Printing Area	103
Set the margins.	103
Using the Media Take-up Unit.....	104
About the Media Take-Up Unit.....	104
Performing Operations from the Dedicated Mobile Operation Application	105
What Is the Dedicated Mobile Operation Application?.....	105
Downloading the Operation Application	106
Using the Operation Application	107
Important Notes on Using the Operation Application.....	108
Other Useful Functions.....	110
Using the Print Light (Interior Light)	110
Performing Printing Tests Arranged Horizontally	111
Using Media Flanges for Paper Tubes (Cores) with an Internal Diameter of 2 Inches	112
Optimizing Operation Management	113
Managing the Operations Appropriately and Efficiently	114
Setting the Current Date/Time and Using It for Maintenance.....	114
Displaying the Amount of Media Remaining	115
Making Sure to Verify the Setting for the Amount Remaining Every Time the Media Is Changed	116
Printing the Amount of Remaining Media	117
Setting the Activation Interval for Sleep Mode (Power-saving Feature)	118
Thoroughly Mixing the Ink Periodically.....	119
Managing the Basic Settings of the Printer	120
Setting the Menu Language and Units of Measurement	120
Turning on Bluetooth Communication	121
Viewing System Information	123
Returning All Settings to Factory Defaults.....	124
Maintenance	125

Introduction	126
Important Notes on Handling and Use	127
Printer	127
Ink Pouches	128
Basic Maintenance Knowledge	129
Types and Timing of Maintenance	129
Measures When the Printer Is Not in Use for a Prolonged Period	130
Regular Maintenance	131
Cleaning the Machine	132
Cleaning the Media Path	132
Cleaning the Knife Carriage Roller	133
Disposing of Discharged Fluid	134
Precautions for Disposing of Discharged Fluid	134
If the Discharged Fluid Disposal Message Appears	135
If the Drain Bottle Exceeds Its Capacity Limit	136
Daily Print Head Check	137
Printing Tests and Normal Cleaning	137
When Normal Cleaning Is Not Effective	140
Medium Cleaning Method	140
Powerful Cleaning Method	142
Manual Cleaning	144
When Manual Cleaning Is Necessary	144
Manual Cleaning Method	145
Consumable Products and Parts Related to Manual Cleaning	151
If Colors Are Uneven	152
Mixing the Ink by Shaking the Pouch Tray	152
Advanced Maintenance	153
When Uneven Color Issues Occur with White Ink	154
Damper Cleaning Method	154
Handling Severe Dot Drop-out and Dot Displacement	157
Super Cleaning Method	157
Partially Restricting the Print Heads Used for Printing	162
Emergency Measure) Cleaning the Print Head Surface	164
Replacing Consumable Parts	165
Replacing Parts for Maintenance	166
Replacing the Wiper and the Tray Pad	166
Cleaning the Wiper Tray	169
Replacing the Separating Knife	171
Troubleshooting Methods.....	173
Output Quality Problems	174
Printed results are coarse or contain horizontal stripes	175
Do the print heads cause dot drop-out?	175
Is the print head height appropriate?	175
Have you carried out feed correction (calibration)?	175
Have you carried out correction of the ink landing position (MEDIA GAP ADJ.)?	175
Is the printer installed in a level and stable location?	175
Is the media heating system at a suitable temperature?	175
Is the temperature of the room too low?	176
Is the print mode suitable?	176
Is the media loaded correctly?	176
Are the settings for the "PRESET" menu item appropriate?	176
The media becomes soiled when printed	177
Do the print heads come into contact with the media?	177

Are the print heads dirty?	177
Are the pinch rollers or the media clamps dirty?.....	177
Colors are unstable or uneven	178
Have you tried mixing the ink by shaking the pouch trays?.....	178
Are colors still uneven after mixing the ink by shaking the pouch trays?	178
Is the media wrinkled?.....	178
Was printing paused partway through?.....	178
Is the printer installed in a level and stable location?.....	178
Is the media loaded correctly?	178
Are the operating parameters set to appropriate values?	179
Are the settings for the "PRESET" menu item appropriate?.....	179
Media Feed Problems	180
Media Wrinkles or Shrinks	181
Is the media loaded and set up straight and securely?	181
Was loaded media allowed to stand for some time?	181
Are the media clamps attached?.....	181
Was the media loaded while the print heater was hot?	181
Are the media heating system temperatures too high?.....	181
Is the temperature of the room too low?	181
Is the humidity of the room too high?.....	181
Is the media sagging?	181
Media Feeding Is Not Straight.....	182
Is the media loaded and set up straight and securely?	182
Media Feeding Is Not Smooth	183
Is some other object coming into contact with the media?	183
Is the media too thick?	183
Are the grit rollers dirty?.....	183
A Media Jam Occurs!	184
Is an error message displayed?	184
Is the media warped or wrinkled?	184
Is the height of the print heads too low?	184
Are the grit rollers dirty?.....	184
Are the media clamps attached?.....	184
Is the media loaded and set up straight and securely?	184
Is some other object coming into contact with the media?	184
Is the media too thick?	185
Machine Problems	186
The Print Heads Do Not Move	187
What to Do First	187
If the Print Heads Still Do Not Move	187
The printer unit does not run	188
Is the power switched on?.....	188
Is [SETUP] lit?	188
Are any covers open?	188
Is the top menu displayed?.....	188
Is [PAUSE] lit?.....	188
Is a message displayed on the screen?	188
Are the cables connected?	188
Is the LAN routing appropriate?	189
Are the LAN settings correct?.....	189
Did the software RIP end abnormally?	189
Has the ink run out?.....	189
The Media Heating System Doesn't Warm Up	190
Is the media loaded?	190
Is HEATER CONFIG set to OFF?.....	190
Is the temperature of the room too low?	190
Cannot Separate the Media	191

Is the separating knife installed?.....	191
Is the cut rail installed?	191
Printer Cannot Be Operated from the Operation Application.....	192
Is the printer's operation panel in use?	192
Is printer-side Bluetooth communication turned on?	192
Is the operation application connected to a different printer?	192
Is the printer-side Bluetooth communication normal?.....	192
Is the distance between the printer and the mobile terminal too far?	192
Are there any obstacles between the printer and the mobile terminal?	193
Is the mobile terminal's Bluetooth function turned on?	193
Is there a wireless LAN unit or anything else in the vicinity that is causing Bluetooth communication to be unstable?	193
Messages on the Operation Panel.....	194
Messages	195
1 ■ 2 ■ 3 ■ 4 ■ 5 ■ 6 ■ 7 ■ 8 ■.....	195
"CLOSE THE COVER"	195
"SHEET NOT LOADED SETUP SHEET"	195
"CLOSE SLOT COVER"	195
"END OF THE SHEET"	195
"EMPTY DRAIN BOTTLE"	195
"INSTALL DRAIN BOTTLE"	195
"NOW HEATING..."	195
"TIME FOR MAINTENANCE"	196
"TIME FOR WIPER REPLACE"	196
"SET CL-LIQUID FOR WIPER"	196
"CHANGE CL-LIQUID FOR WIPER"	196
"TIME FOR TRAY CLEANING"	196
"HEAD PROTECTION ACTIVATED"	196
"SHAKE ALL INK POUCH TRAY"	196
Error Messages.....	198
"OPTION DRYER IS NOT CONNECTED"	198
"TEMPERATURE IS TOO LOW **° C"	198
"TEMPERATURE IS TOO HIGH **° C"	198
"CAN'T PRINT CROP CONTINUE?"	198
"SHEET TOO SMALL CONTINUE?"	198
"DATA ERROR CANCELING..."	198
"SHEET SET ERROR SET AGAIN"	199
"PINCHROLL ERROR LOWER PINCHROLL"	199
"WRONG CARTRIDGE 12345678"	199
"CANCELED FOR PUMP PROTECTION"	199
"AVOIDING DRY-UP TURN POWER OFF"	199
"SET HEAD HEIGHT TO ****"	199
"MOTOR ERROR TURN POWER OFF"	199
"SERVICE CALL ****"	200
"CLEANING ERROR"	200
Appendix.....	201
Operations When Moving the Unit	202
Preparing to Move the Machine	203
Step 1: Removing the Media	203
Step 2: Circulating the Ink (Only When Using White Ink).....	204
Step 3: Discharging the Wiper Tray Cleaning Liquid.....	205
Step 4: Secure the print heads in place using the retainer.	207
Step 5: Reinstalling the Machine	208
Main Specifications	209
Maximum Printing Area and Margins	210

Contents

Maximum Printing Area When Using Crop Marks 211
Media Separation Location during Continuous Printing 212
Memo.....213

Basic Handling Methods

Basic Information

Part Names and Functions.....	9
Printer Unit.....	9
Operation Panel	14
Display Screen	15
About the Media Used	16
Types of Media	16
Conditions for Usable Media	17
Menu List.....	18
Main Menu	18
Function Menu	21
Language and Unit Menu	22

Part Names and Functions

Printer Unit

Front

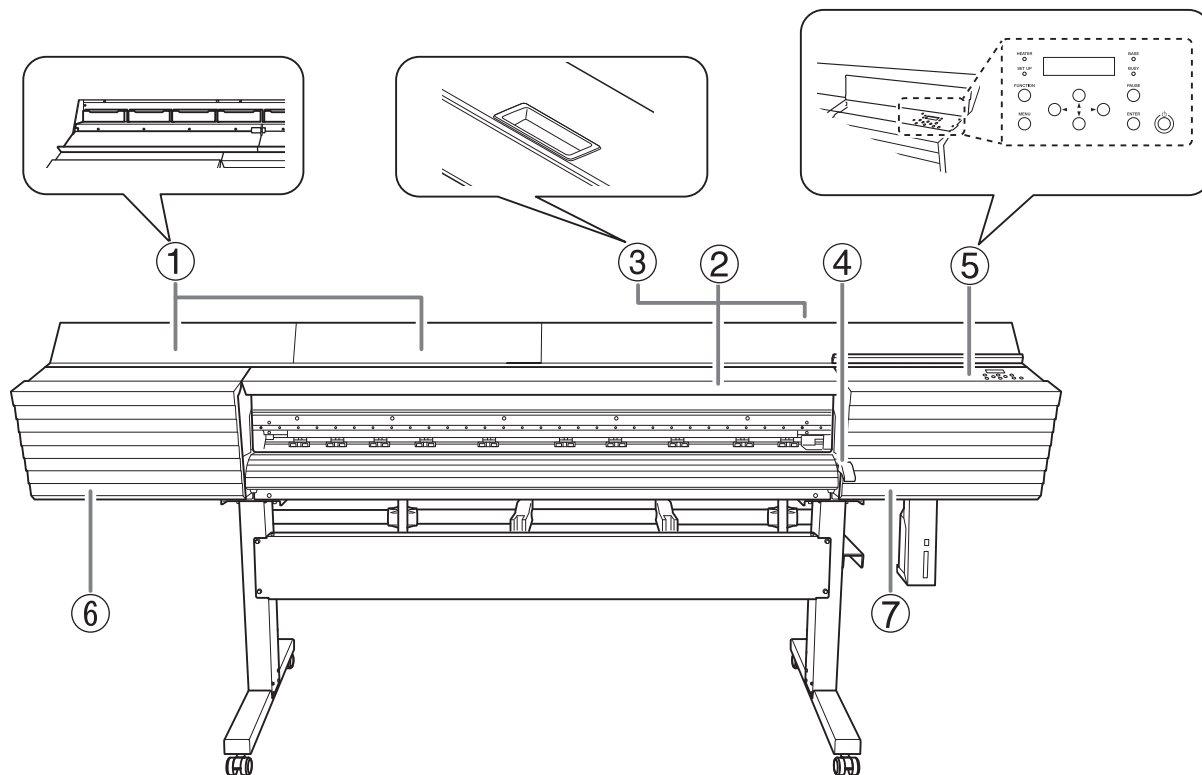

No.	Name	Function overview
①	Ink slot cover, ink slots	Open this cover to access the slots in which the pouch trays are inserted. Leave this closed except when switching pouch trays.
②	Front cover	Open this when necessary, such as when loading media. In all other situations, keep the front cover closed.
③	Small article storage	This is a useful space in which you can place small articles. IMPORTANT Do not place in this area any items to which cleaning liquid or ink has affixed.
④	Loading lever (front)	Operate this when you load media.
⑤	Operation panel	The panel containing the buttons used to operate the machine. ➤ P. 14 "Operation Panel"
⑥	Left cover	Open this when you perform maintenance.
⑦	Right cover	Open this when you perform maintenance.

 Rear

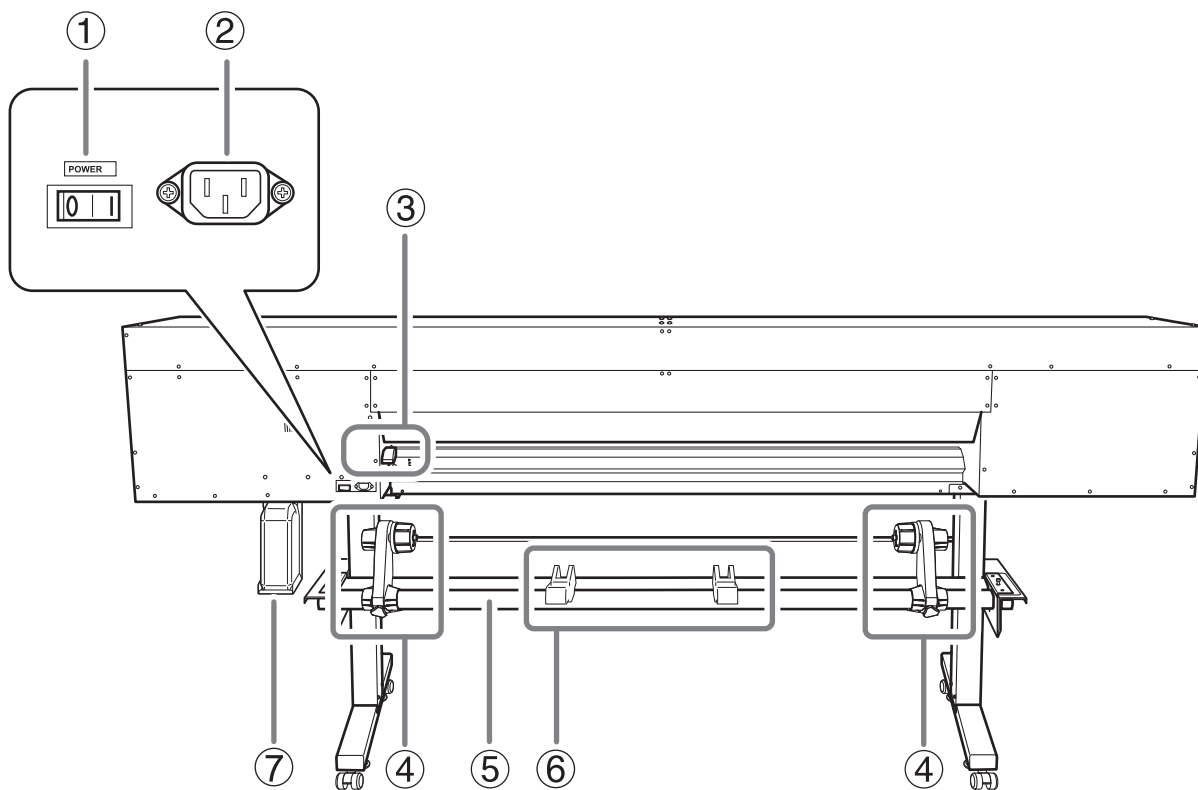

No.	Name	Function overview
①	Main power switch	Switch the main power on/off.
②	Power-cord connector	Use this to connect the power cable.
③	Loading lever (rear)	Operate this when you load media.
④	Media holders	Use these when you load media.
⑤	Shafts	
⑥	Media stays	
⑦	Drain bottle	Discharged fluid is stored in this bottle.

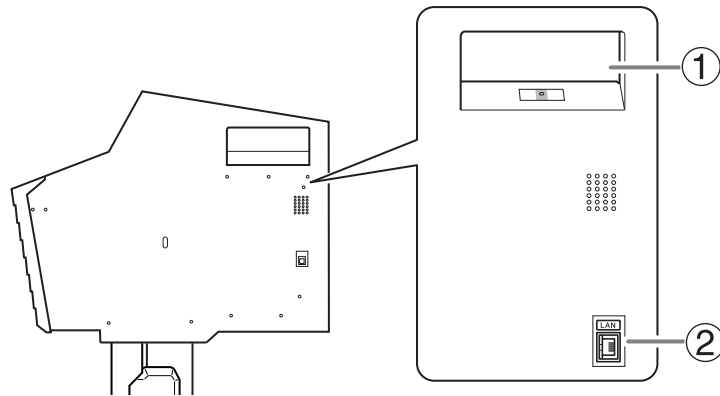
 Side

No.	Name	Function overview
①	Cleaning liquid slot	Insert the pouch tray with the TR2 cleaning liquid pouch into this slot.
②	Ethernet connector	Use this to connect an Ethernet cable.

Front Cover Interior/Print Head Area

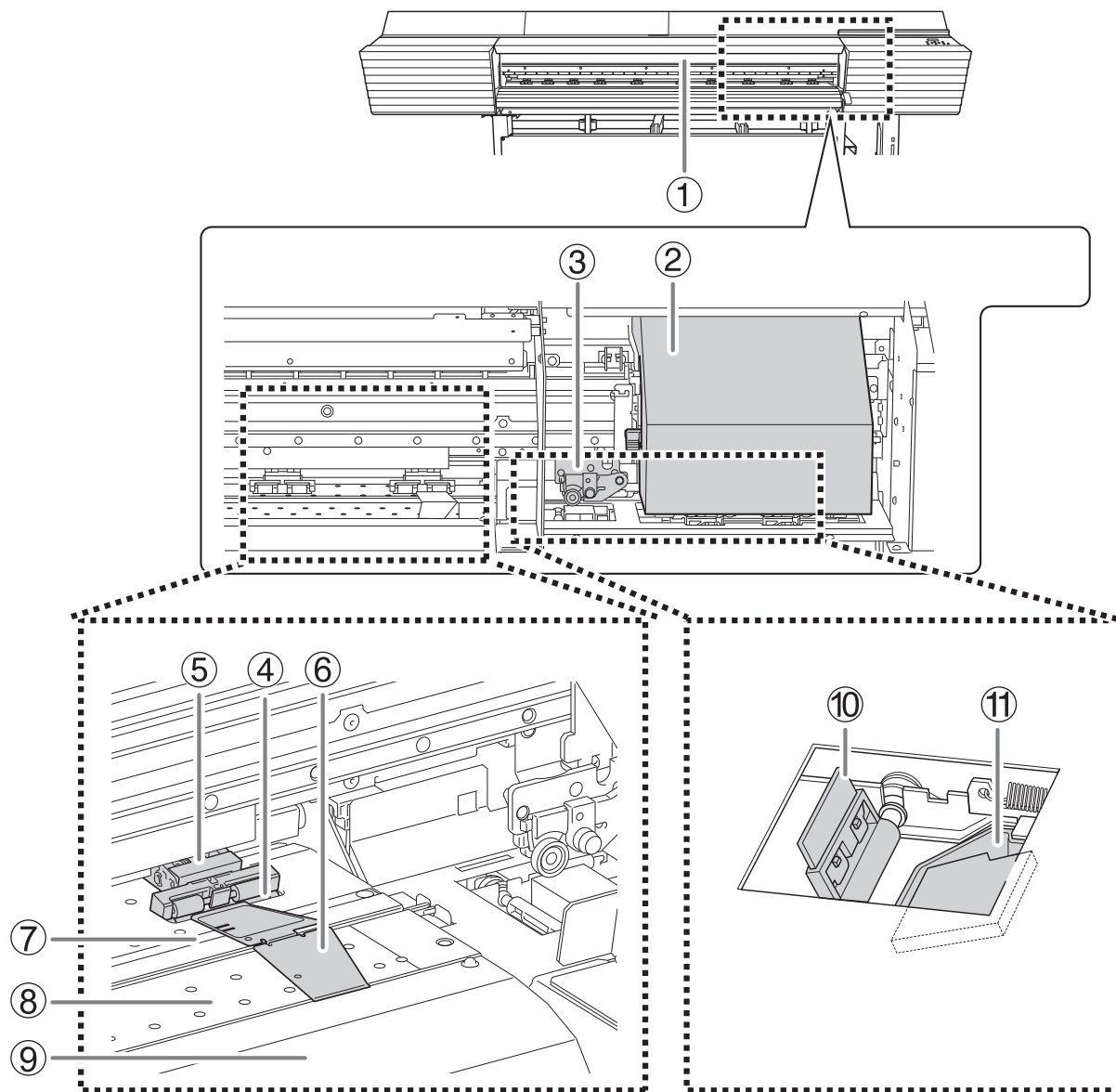

No.	Name	Function overview
①	Print light	This light illuminates the front cover interior. This makes it easier to see the printing status. It flashes if a serious error occurs.
②	Print-head carriage	The print heads are inside here.
③	Separating knife	This cuts off the media.
④	Grit roller	These rollers feed the media.
⑤	Pinch roller	This clamps the media when the loading lever is lowered.
⑥	Media clamp	This clamps the edge of the media to keep it from coming loose. It also prevents fuzz on the cut edge of the media from touching the print heads.
⑦	Reflective tape	This is used when detecting the media.
⑧	Platen	This is the path over which the media passes. A suction fan that keeps the media from coming loose and a print heater that helps fix the ink are built in.
⑨	Apron	This has a built-in dryer to speed up drying of the ink.

No.	Name	Function overview
⑩	Wiper	Cleans the print heads during automatic cleaning and in similar situations.
⑪	Wiper tray	This tray houses the TR2 cleaning liquid used to clean the wiper. It contains a tray pad.

RELATED LINKS

- P. 13 "Serious Errors Indicated by the Print Light"
-

Serious Errors Indicated by the Print Light

If an error that may lead to serious damage to the printer occurs, the print light blinks.

This indicates one of the situations shown below.

When the print light blinks, the error also appears on the operation panel's display screen.

Display screen	Error overview
"AVOIDING DRY-UP TURN POWER OFF"	The print heads were about to dry out. The print heads may be damaged if allowed to dry out.
"MOTOR ERROR TURN POWER OFF"	An excessive load was applied to the motor. If this error is not addressed, the print heads may be damaged.
"TEMPERATURE IS TOO LOW **° C"	The ambient temperature in the printer's installation location has fallen below the temperature in which operation is possible. If this error is not addressed, the printer may malfunction.
"TEMPERATURE IS TOO HIGH **° C"	The ambient temperature in the printer's installation location has risen above the temperature in which operation is possible. If this error is not addressed, the printer may malfunction.
"CANCELED FOR PUMP PROTECTION"	An excessive load was applied to the pump within the machine. If this error is not addressed, the pump may malfunction.
"SERVICE CALL *****"	An unrecoverable error or an error that requires a part replacement has occurred.

RELATED LINKS

- P. 198 "Error Messages"
-

If a Cover Opens during Operation

If the front cover, left cover, or right cover (hereinafter referred to as "cover") opens during an output operation or while setting up the media, the machine makes an emergency stop. When an emergency stop occurs, a message prompting you to close the cover appears on the screen. Close the covers as directed in the instructions shown on the screen.

When the cover is closed, you will be able to continue the operation.









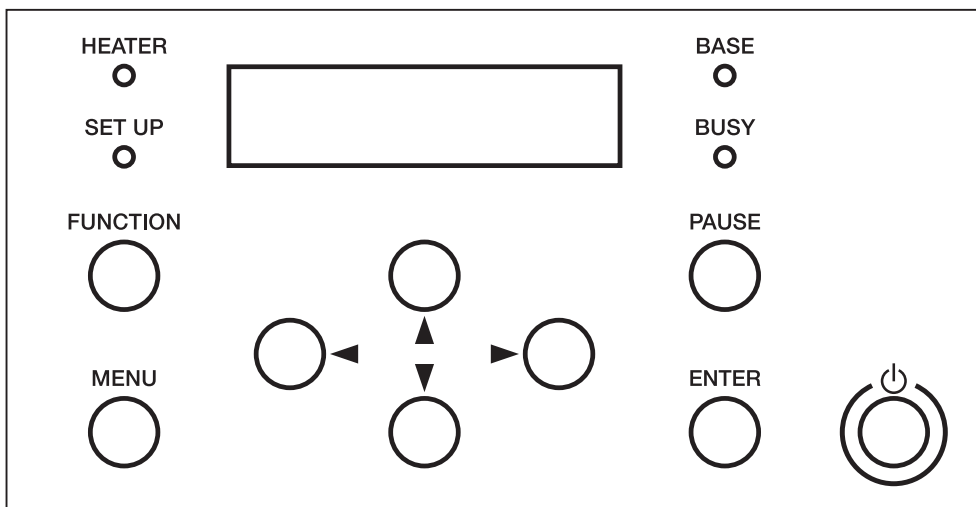

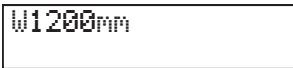
If you cannot continue the operation even after you close the cover, a nonrecoverable error may have occurred.

RELATED LINKS

- P. 198 "Error Messages"
-

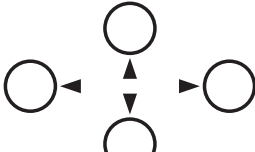
Operation Panel



Part	Name	Details	Notation in this manual
	Display screen	This displays various setting menus and other information.	
	Sub power switch	This switches the printer on and off. (To switch the printer off, hold down the switch for one second or longer). The light flashes slowly when the machine is in sleep mode.	
	ENTER key	Use this for such tasks as enabling setting values.	[ENTER]
	MENU key	Press this to enter the menus for various settings.	[MENU]
	FUNCTION key	You press this when entering the setting menu for cleaning of the print heads, printing tests, and so on.	[FUNCTION]
	PAUSE key	This pauses the printing operation. It lights when operation is paused.	[PAUSE]
	Cursor keys	Use these to select settings for menu items, to move the media, and for other such operations.	[◀][▼][▲][▶]
	BUSY light	This lamp lights up during printing and other such operations.	[BUSY]
	SETUP light	This lights when media has been loaded correctly.	[SETUP]
	BASE POINT light	This lights when the base point (the output-start location) has been set.	"BASE"
	HEATER light	This flashes while the media heating system is warming up. It stays lit when the set temperature is reached.	[HEATER]

Display Screen



①

②

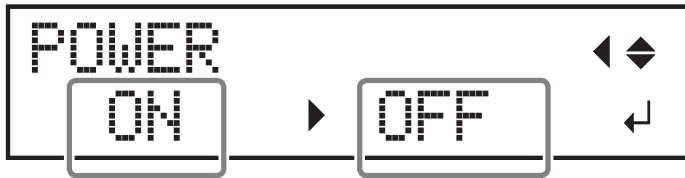

③

④

①	Cursor		Displays the setting to be changed. You can move it with the cursor keys.
②	Direction mark	◀ ▲ ▼ ▶	You can select settings and switch screens by pressing the cursor keys indicating directions.
	ENTER mark	↵	Press [ENTER] to set the selected setting or execute the processing.
③	Present value		The present value (before change) is displayed.
④	Setting value		Select the setting you want to set (after change).

About the Media Used

Types of Media

In this manual, the paper used for output is called "media." The two main types of media used in this machine are shown below.

- Roll media: Media wound onto a paper tube
- Sheet media: Media not wound onto a paper tube such as standard-size media

Various paper types of roll media and sheet media are selectable according to your purpose. For detailed information about each media, contact your media supplier.

Conditions for Usable Media

This machine cannot print on every kind of media. When selecting media, be sure to carry out testing in advance to make sure that satisfactory printing results are obtained.

Size

	VF2-640
Width *1	259 to 1,625 mm*2 (10.2 to 64.0 in.)
Maximum media thickness (including backing paper)*1	1.0 mm (39.4 mil)
Maximum roll outer diameter	210 mm (8.2 in.)
Paper tube (core) inner diameter	76.2 mm (3 in.) or 50.8 mm (2 in.) *3

*1 Applies to both roll and sheet media

*2 When using media with a width smaller than 275 mm (10.8 in.), load the media with the media clamps removed.

*3 To use 2-inch media, the optional media flanges are required. For information about optional items, contact your authorized Roland DG Corporation dealer or visit our website (<http://www.rolanddg.com/>).

Maximum Roll Weight

- 40 kg (88 lb.)

MEMO

If using the take-up unit, this specification depends on the conditions of the take-up unit.

Other Conditions

Media such as the following cannot be used.

- Media whose end is attached to the paper tube (core)
- Media that is severely warped or that has a strong tendency to reroll
- Media that cannot withstand the heat of the media heating system
- Media whose paper tube (core) is bent or crushed
- Media that bends under its own weight when loaded
- Media on a sagging roll
- Media that is rolled unevenly

RELATED LINKS

- P. 210 "Maximum Printing Area and Margins"

Menu List

Main Menu

Press [MENU].

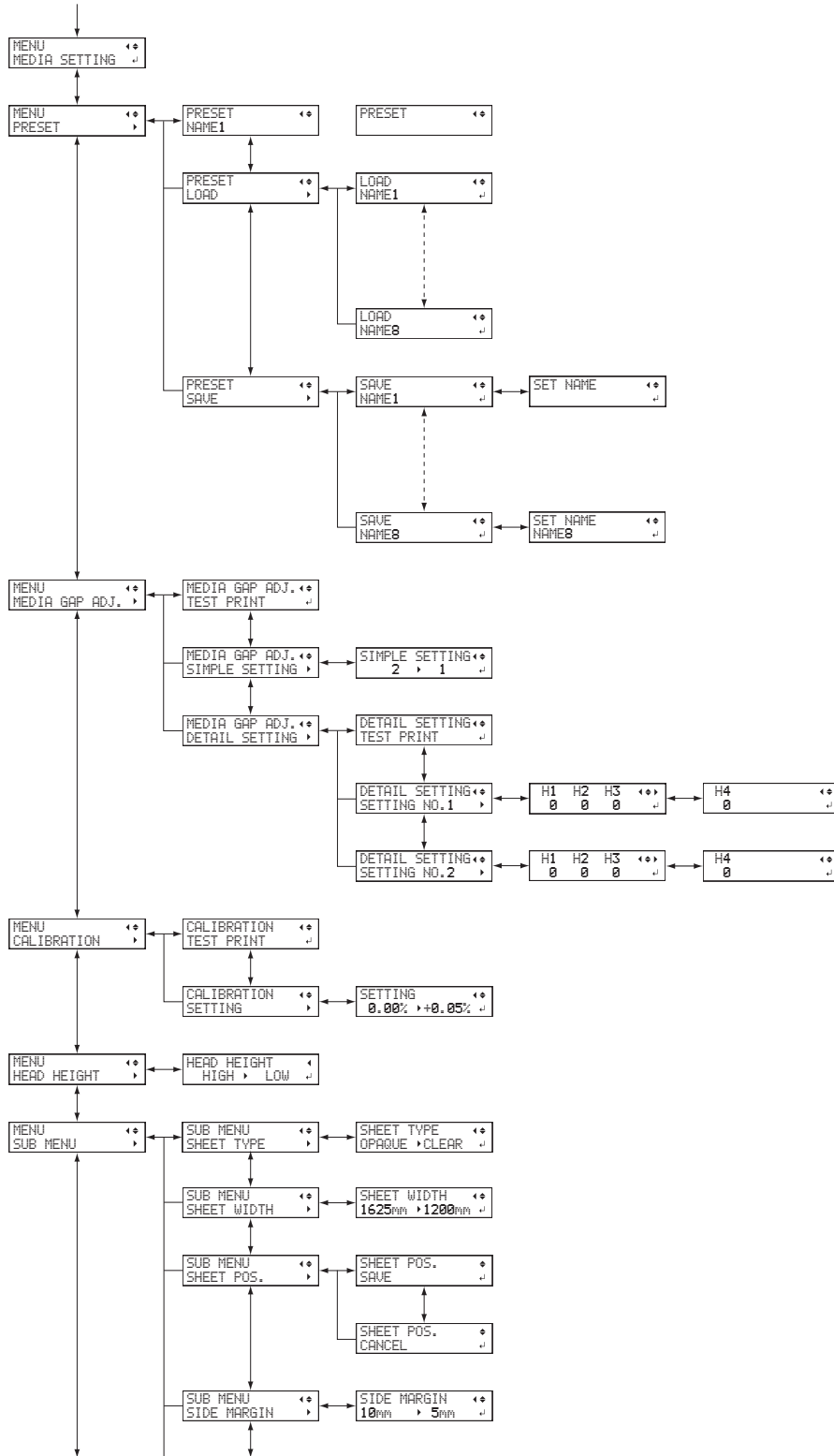

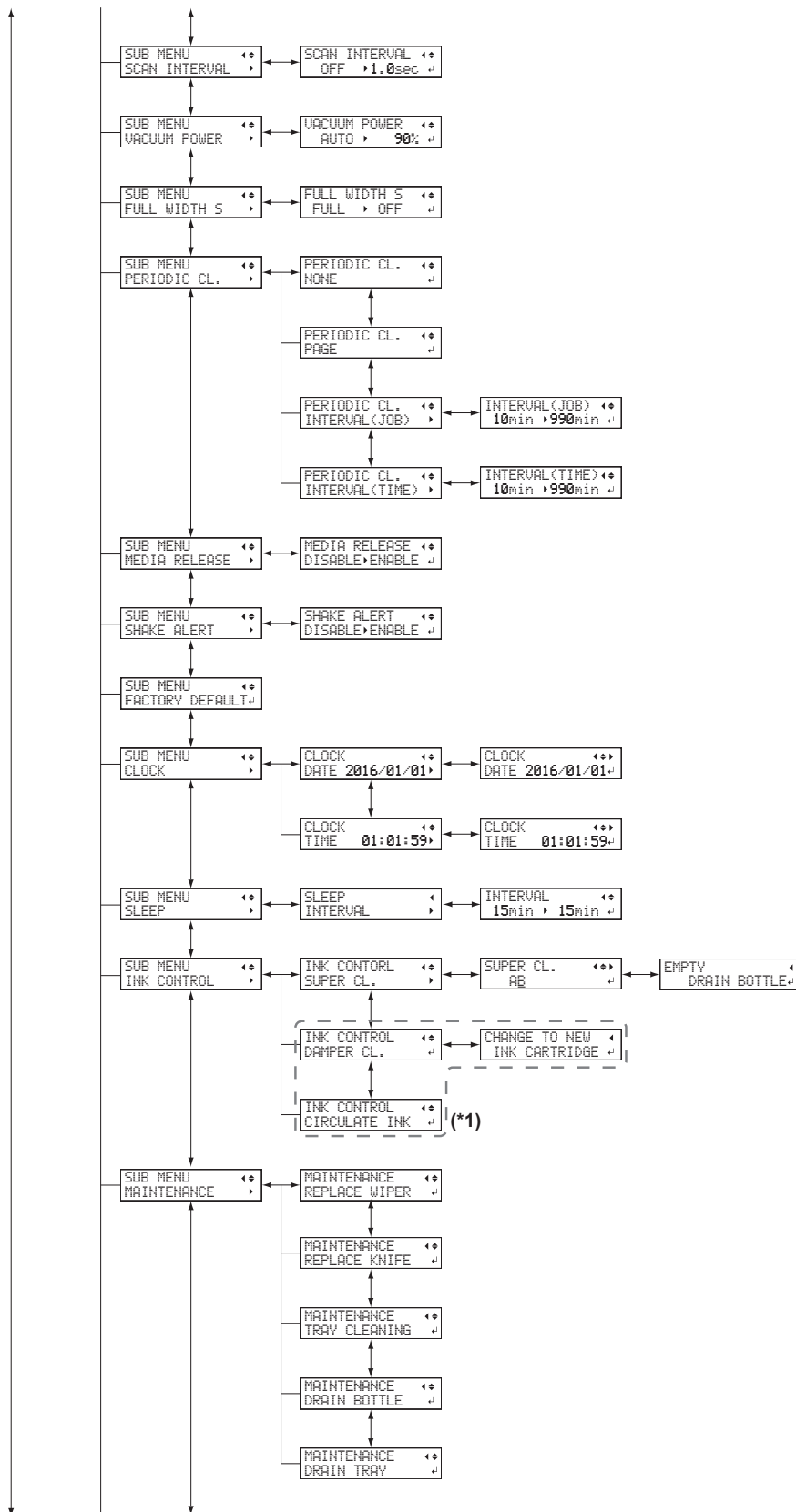

(*1) This is only displayed when you are using eight colors (CMYKLcLmLkW or CMYKLkOrGrW).

Menu List

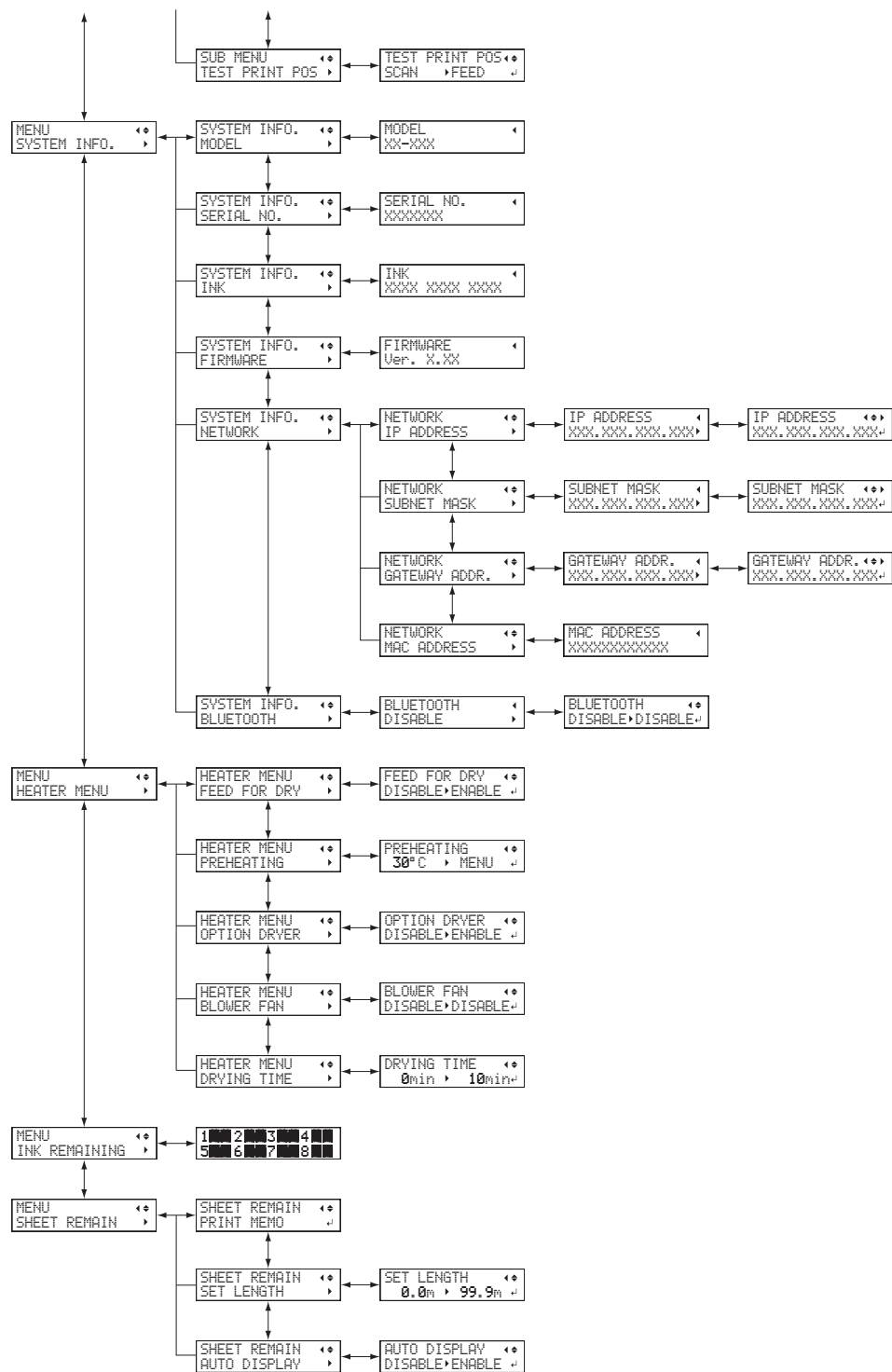

Function Menu

Press [FUNCTION].

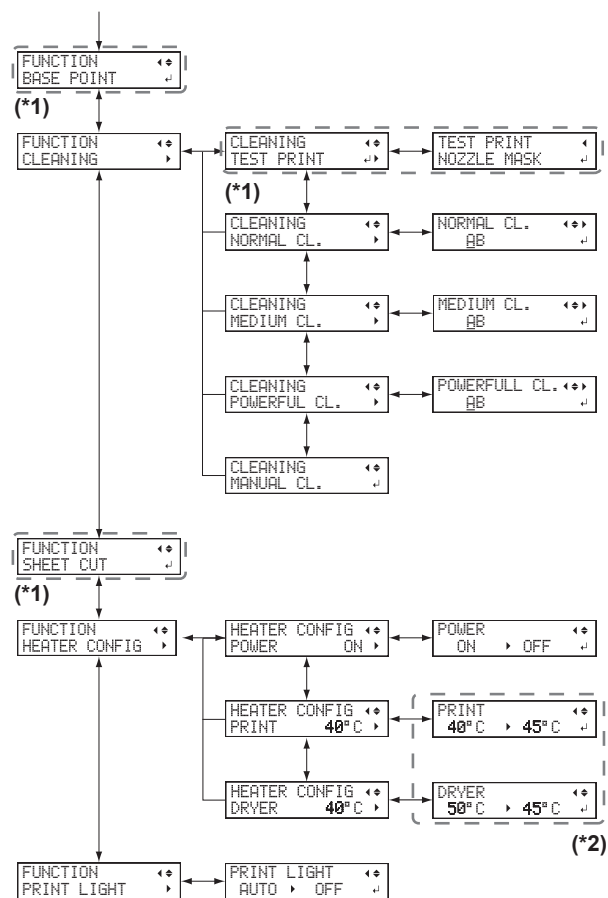

(*1) This is displayed when the width of the media is displayed after the media has been loaded.

(*2) This is not displayed when "POWER" under "HEATER CONFIG" is set to "OFF".

Language and Unit Menu

Hold down [MENU] and switch on the sub power.

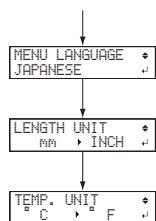

Basic Operations

Power Supply Operations	24
Turning the Power On	24
Turning the Power Off	25
Precautions When Operating the Power Supply	26
Sleep Mode (Power-saving Feature)	27
Setup of Media	28
Setup of Roll Media	28
Setup of Sheet Media	35
Separating the Media	39
What to Do First after Installation	40
Accurately Adjusting the Misalignment of the Ink Landing Position	40
Checking before Output	42
LAN (Local Area Network) Settings	42
Preventing Sedimentation in Inks	43
Pausing and Canceling Output	44
Pausing and Resuming Output	44
Canceling Output	45
Ink Pouch/TR2 Cleaning Liquid Pouch Replacement	46
Out-of-ink Warnings	46
Out-of-TR2-cleaning-liquid Warnings	47
Ink Pouch Replacement	48
TR2 Cleaning Liquid Pouch Replacement	50

Power Supply Operations

Turning the Power On

⚠ WARNING

When output is not being performed, remove any loaded media or switch off the sub power.

The continued application of heat at a single location may cause the release of toxic gases from the media or pose a fire hazard.

Procedure

1. Close the front cover.

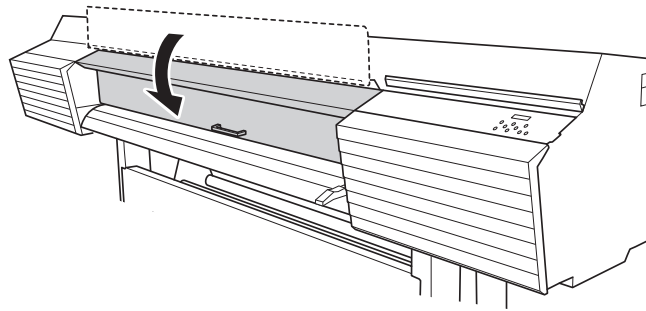

2. Turn on the main power switch.

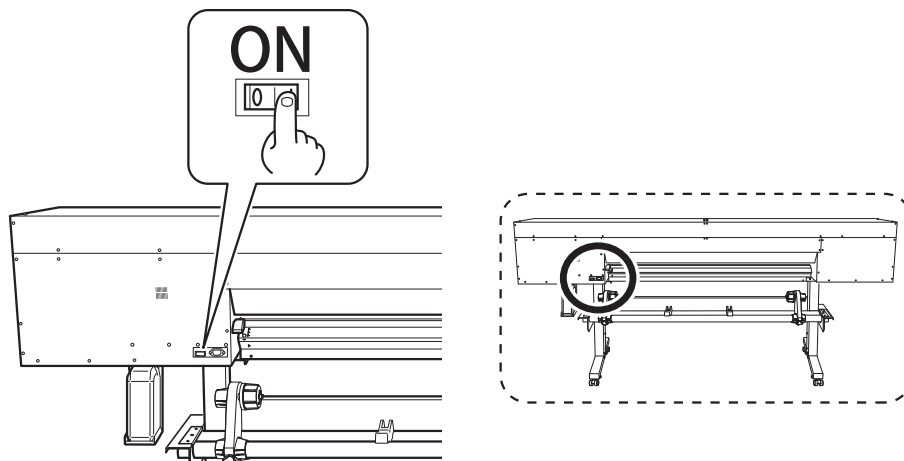

3. Press the sub power button.

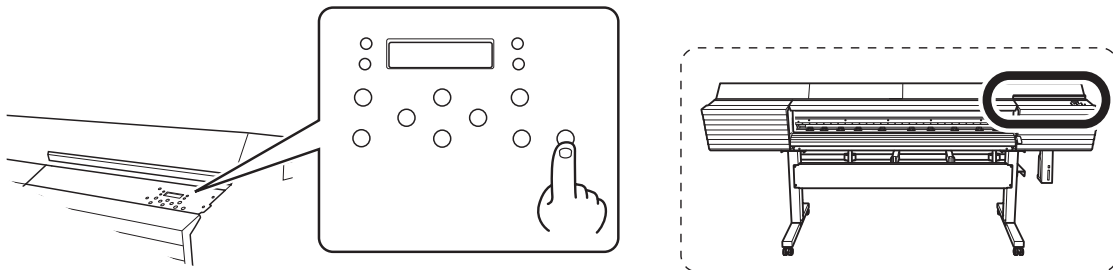

Turning the Power Off

- ⚠ WARNING** When output is not being performed, remove any loaded media or switch off the sub power.
The continued application of heat at a single location may cause the release of toxic gases from the media or pose a fire hazard.

Procedure

1. Switch off the sub power whenever printing is finished.
Hold down the sub power switch for 1 second or longer.

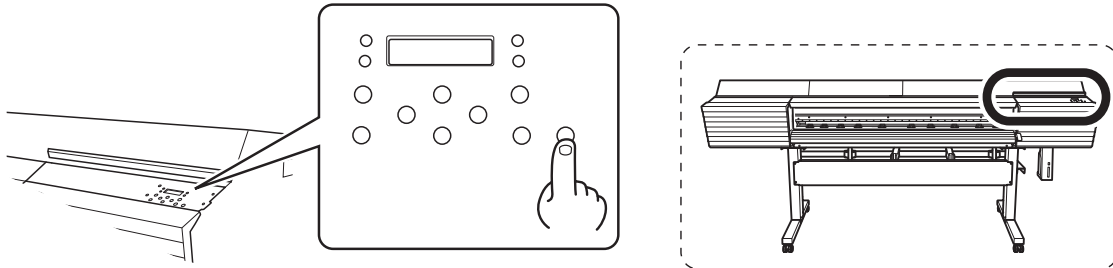

2. Raise the loading lever and remove the media.
When not using the machine, raise the loading lever even if the sub power is on.

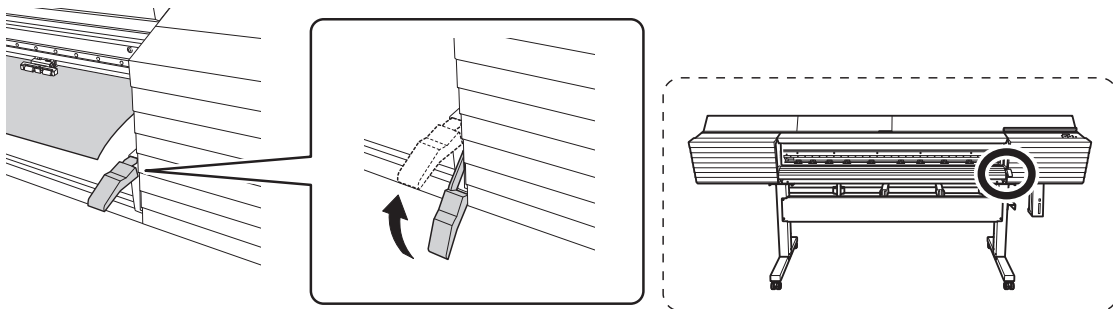

Precautions When Operating the Power Supply

IMPORTANT

Always keep the main power switched on.

Never switch off the main power. Leaving the main power enables automatic maintenance to be carried out periodically. If the automatic maintenance is not carried out, it may result in the breakdown of this machine, such as the breakdown of the print heads.

Never switch off the main power or unplug the power cord suddenly while operation is in progress.

Switching off the main power or unplugging the power cord suddenly while operation is in progress may damage the print heads. Be sure to first switch off the sub power. If the main power is accidentally switched off, immediately turn the main power and sub power back on.

Sleep Mode (Power-saving Feature)

This machine is provided with a power-saving feature that switches to a low-power "sleep mode" when a fixed interval passes with no operation. The factory default for the time after which the machine switches to sleep mode is 30 minutes. When the machine is in the sleep mode, the sub power switch flashes slowly. Using the operation panel or performing operations such as sending print data from the computer restores the machine to its normal mode.

This sleep mode setting can be changed. However, we recommend setting the activation time for sleep mode to 30 minutes or less to reduce power consumption and prevent problems such as overheating.

RELATED LINKS

- P. 118 "Setting the Activation Interval for Sleep Mode (Power-saving Feature)"
-

Setup of Media

This section explains how to set up opaque media. For details on how to set up transparent media, see "Using Transparent Media(P. 79)" .

Setup of Roll Media

Load the roll media on the printer. When you have finished loading the media, [SETUP] lights. This work is referred to as "Setup of Media."

- ⚠ CAUTION** **Load roll media correctly.**
Otherwise the media may fall and cause injury.
- ⚠ CAUTION** **The roll media is approximately 40 kg (88 lb.).**
To avoid injury, handle the roll media with care.
- ⚠ CAUTION** **Never load media that weighs over 40 kg (88 lb.).**
The machine may fail to withstand the weight and tip over or cause the media to fall.

1. Install the media on the media holders.

The media holders of this machine are designed to be used exclusively with media that has a paper tube (core) with an inner diameter of 3 inches. To use 2-inch media, the optional media flanges are required. For information about optional items, contact your authorized Roland DG Corporation dealer or visit our website (<http://www.rolanddg.com/>).

Procedure

1. Open the front cover.
2. Move the media clamps to the outside of the grit rollers on the left and right edges respectively.

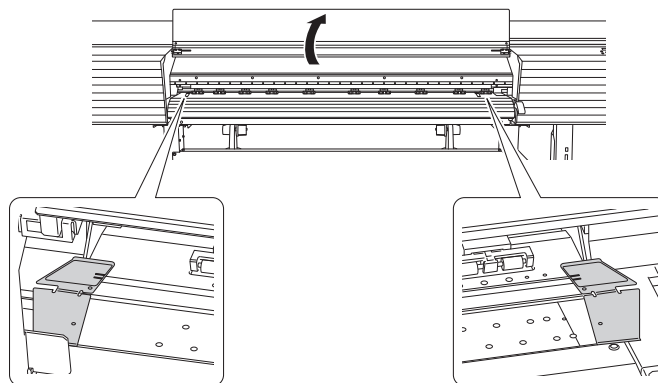

3. Loosen the retaining screws of the media holders, and then draw them to the left and right ends respectively.

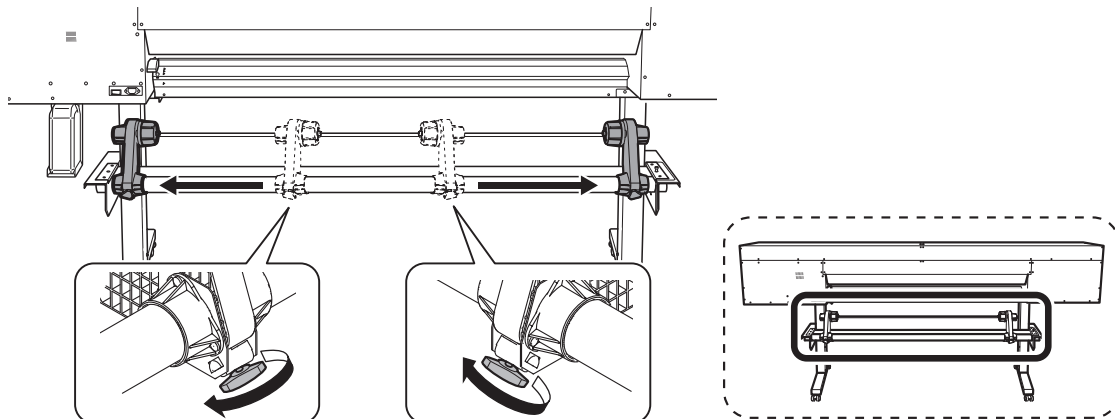

4. Place the media on the media stays.

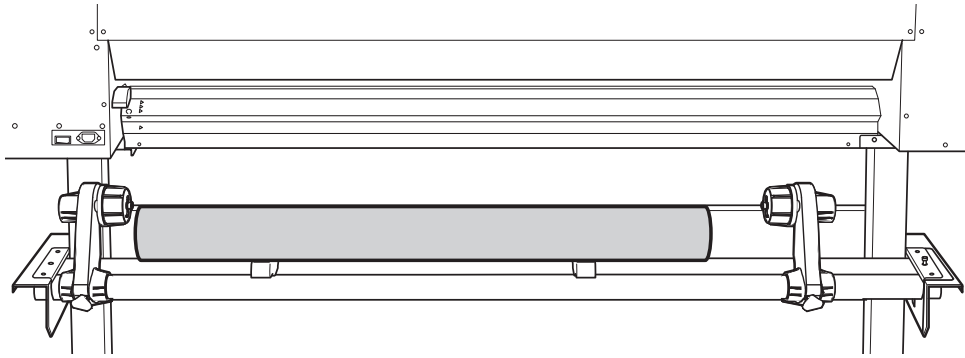

Point

Place the media stays at positions that are $1/4$ the length of the media from each end of the media.

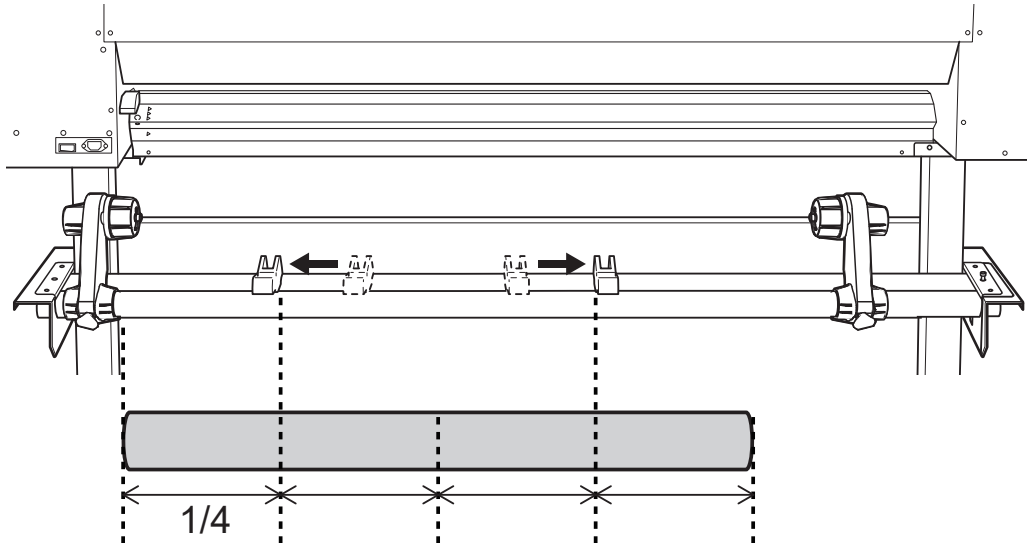

IMPORTANT

Do not leave media on the media stays for a long period of time. Doing so may lead to the media becoming deformed. Exercise caution.

5. Fit the paper tube (core) of the media onto the end cap of the left media holder.

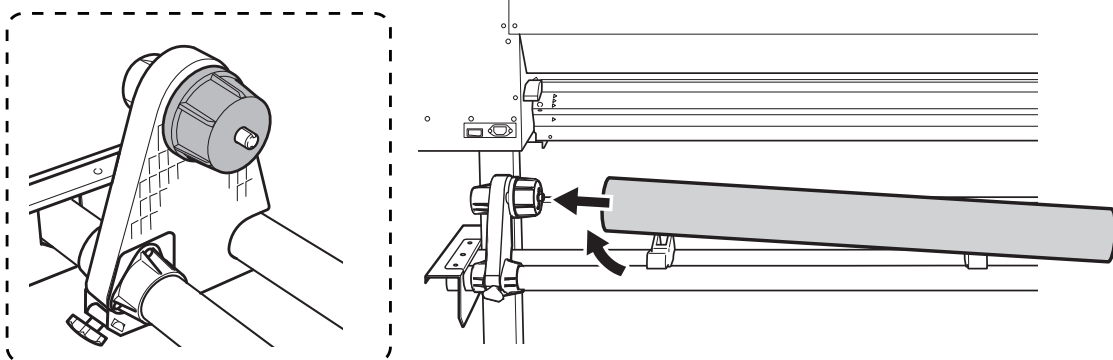

6. Move the right media holder to fit its end cap onto the paper tube (core) of the media.

Fit the paper tube onto the media holders securely to prevent the media from moving easily.

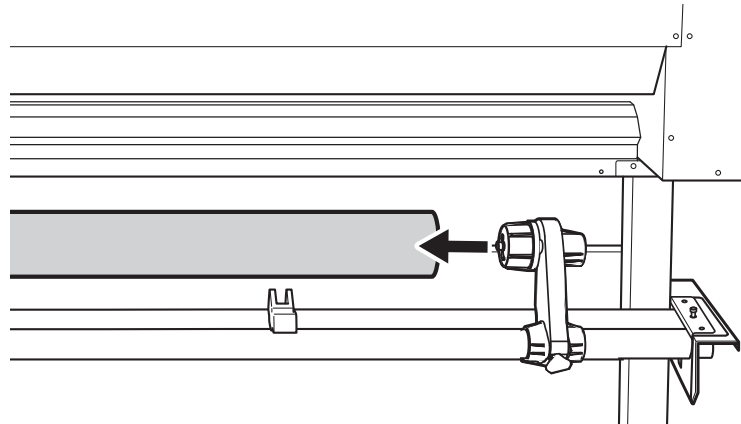

IMPORTANT

Position the left media holder correctly.

If the position of the left media holder is incorrect, media may not be fed properly, which will have an adverse effect on the printing results. Use the following procedure to determine the appropriate position.

Do not secure the media holders in place just yet.

In the following procedure, you will adjust the positions of the media holders before securing them in place. Do not secure them in place just yet.

IMPORTANT

Do not touch the media holder adjuster.

The media holder adjuster is an important part that adjusts the position of the media. When this machine is installed, a suitably qualified worker performs an optimal adjustment that matches the installation environment. Changing the adjusted position of the media holder adjuster may lead to the media feeding at an angle or other adverse effects.

If you change the media holder adjuster position by mistake, contact your authorized Roland DG Corporation dealer.

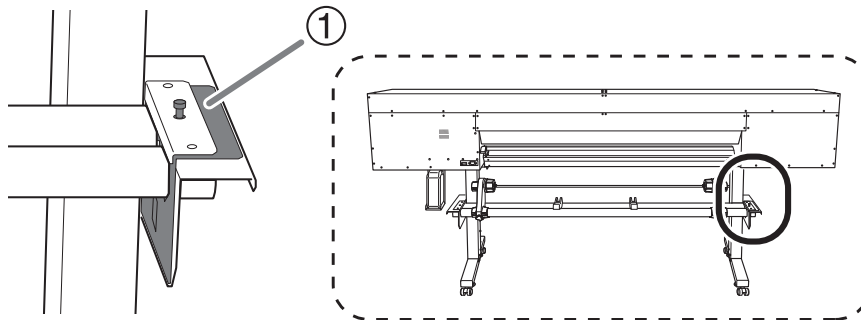

①: Media holder adjuster

2. Determine the positions of the media.

Procedure

1. Align the left edge of the media with the mark.

Move the media holders so that the edge of the media is on the right side of the mark.

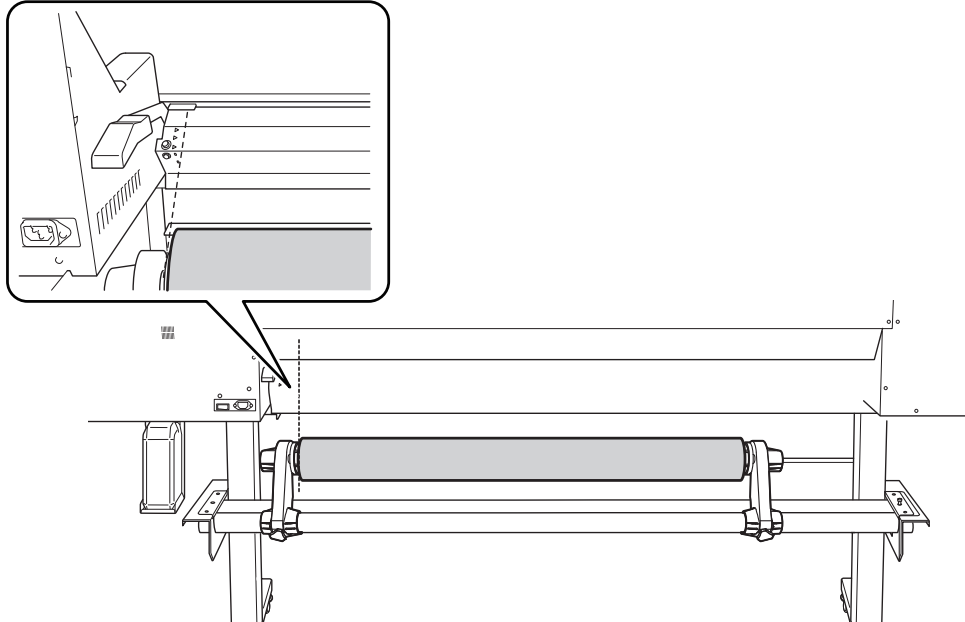

Hold the media holders from the outside and move the media.

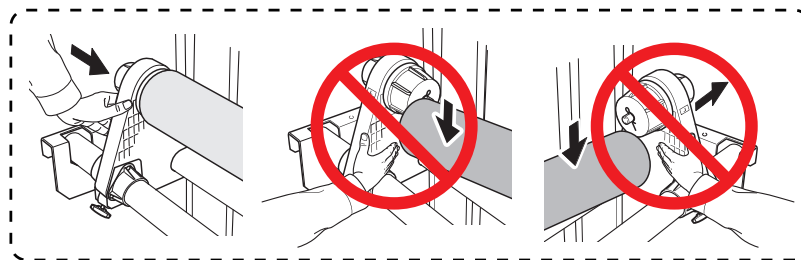

⚠ CAUTION

Do not hold places other than those instructed. Do not move the media by holding it directly.

Otherwise the media may fall off the media holder and cause injury.

IMPORTANT

Firmly decide the left and right side positions of the media at this point.

After this procedure is completed, if the left and right side positions do not fit the proper positions when securing the media with pinch rollers, you will have to go back to this step to redo this procedure. If you just hold the media to readjust its position forcibly, the media will be skewed during printing, which will have an adverse effect on the printing results.

2. Secure the media holders by tightening the retaining screws.

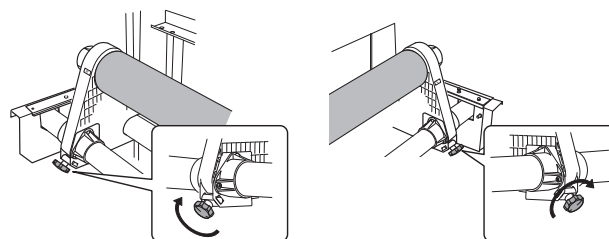

3. Pass the leading edge of the media between the pinch rollers (①) and the grit rollers (②).

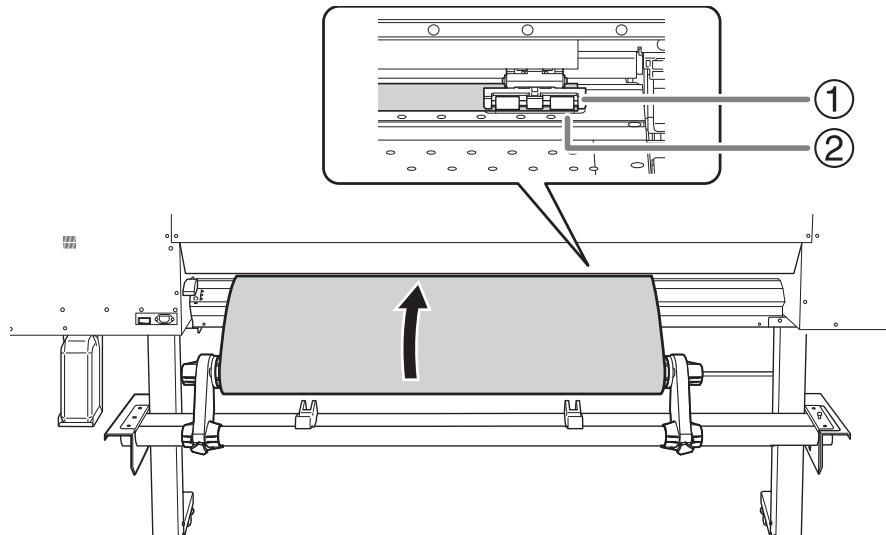

4. Lower the loading lever (rear).

The media is held in place.

At this time, the message "PRESS ENTER KEY TO SET UP" is displayed on the screen, but do not press [ENTER] yet, and proceed to the next step.

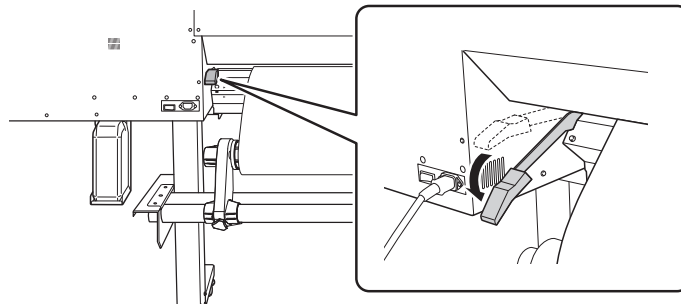

5. (Move to the front of the printer.) Gently hold down the media and raise the loading lever (front).

The media is released.

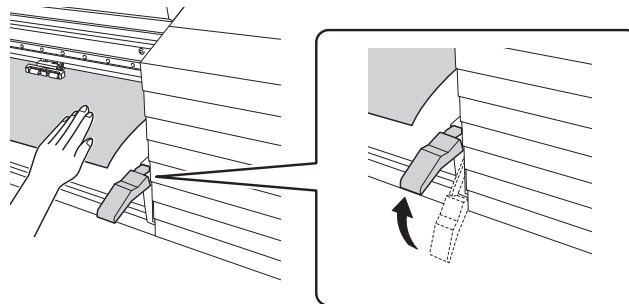

6. Hold the media at the center and pull it out, being sure to keep it straight and all areas of the media to be taut.

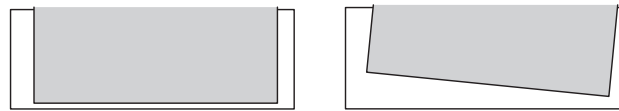
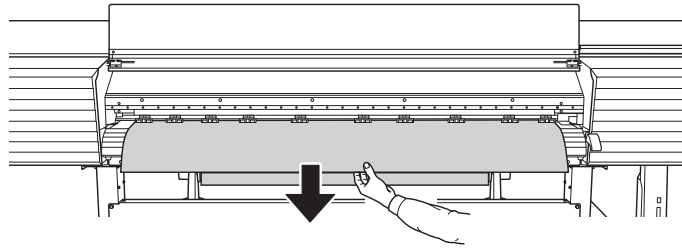

Good

Not good

- 7.** Make sure the right edge of the media is in line with the guide line.

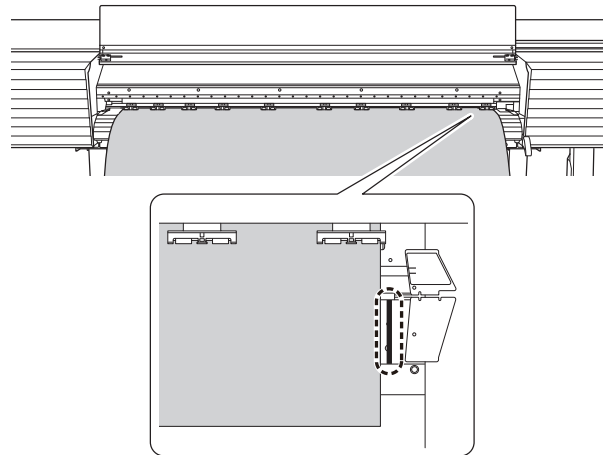

Point

If you want to readjust the media position before securing it in place, redo the procedure from step 2-1. If you just hold the media to readjust its position forcibly, the media will be skewed during printing or will come loose, which will have an effect on the printing quality.

- 8.** Lower the loading lever (front).

The media is held in place.

At this time, the message "PRESS ENTER KEY TO SET UP" is displayed on the screen, but do not press [ENTER] yet, and proceed to the next step.

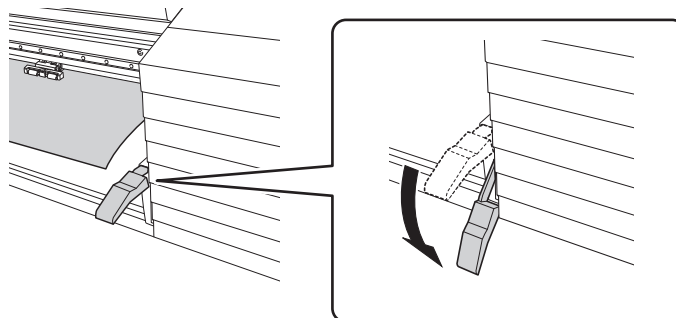

- 9.** Line up the edges of the media with the centers of the holes of the media clamps (left and right).

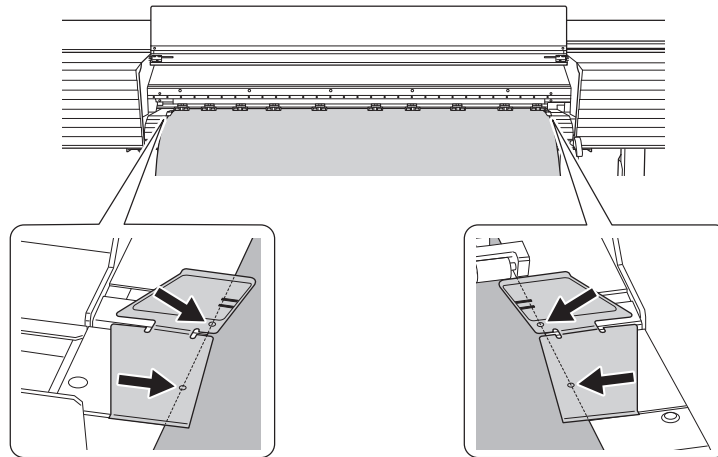

IMPORTANT

Be sure to use the media clamps when you load media.

If you attach the media clamps directly before printing after the media setup is complete, the machine may print on the media clamps.

MEMO

Press down on the bent part of the media clamps to lift up both of their edges. Move the media clamps to the left and right with both edges lifted up.

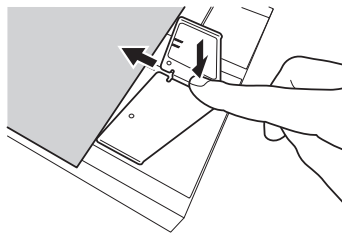

10. Close the front cover.

11. Press [ENTER].

When you press [ENTER], the print-head carriage moves and detects the width of the media. This operation is called initialization. When initialization ends, [SETUP] on the operation panel lights, and the printable width is displayed on the screen. This completes the setup of the media.

IMPORTANT

Remove when not using roll media.

Do not leave roll media loaded on the machine for a long period of time. Be sure to remove and store the media when not in use. Leaving the roll media loaded on the machine for a long period of time will cause the media to sag, which may deteriorate the printing quality and may also lead to motor errors.

Setup of Sheet Media

Load the sheet media on the printer. When you have finished loading the media, [SETUP] lights. This work is referred to as "Setup of Media."

1. Determine the positions of the media (sheet media).

Procedure

1. Open the front cover.
2. Move the media clamps to the outside of the grit rollers on the left and right edges respectively.

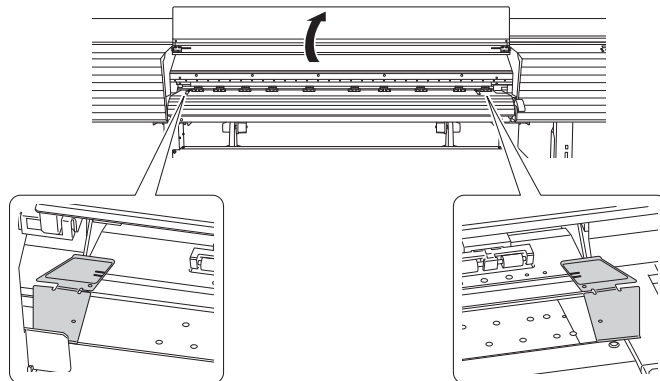

3. Loosen the retaining screws of the media holders, and then draw them to the left and right ends respectively.

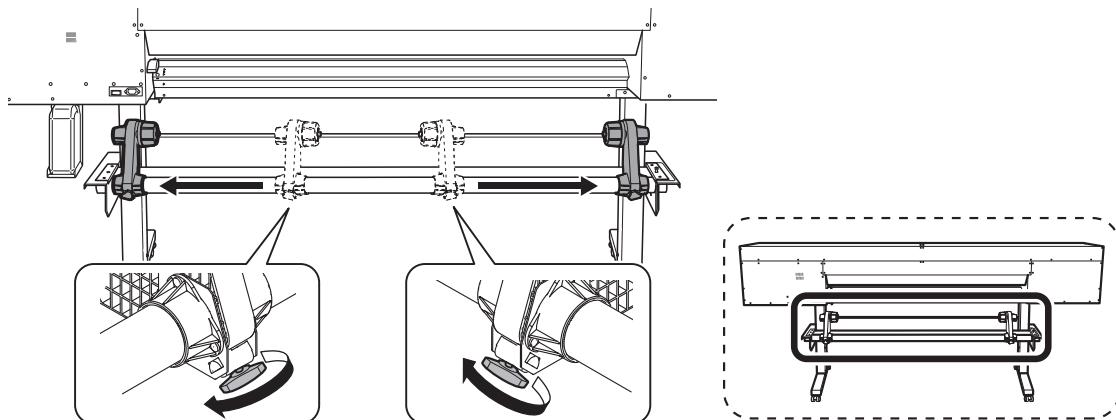

4. Pass the leading edge of the media between the pinch rollers (①) and the grit rollers (②).

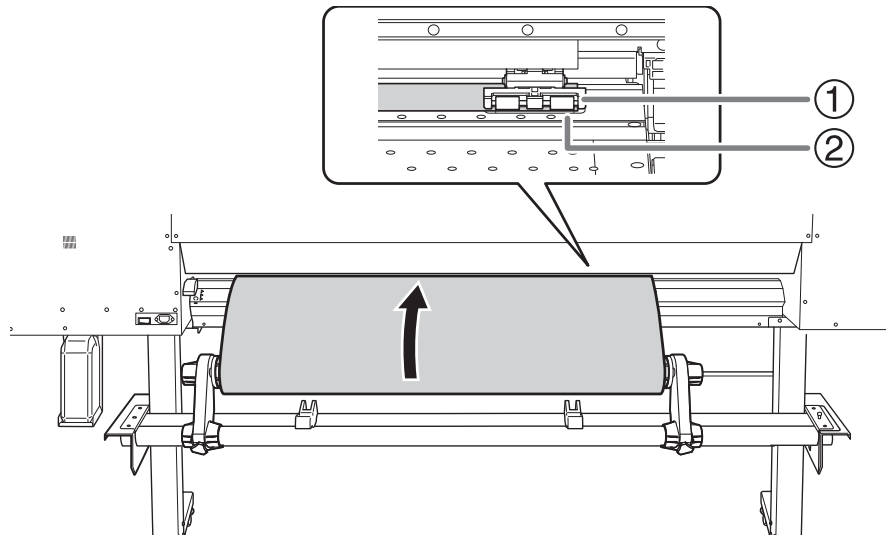

5. Lower the loading lever (rear).

The media is held in place.

At this time, the message "PRESS ENTER KEY TO SET UP" is displayed on the screen, but do not press [ENTER] yet, and proceed to the next step.

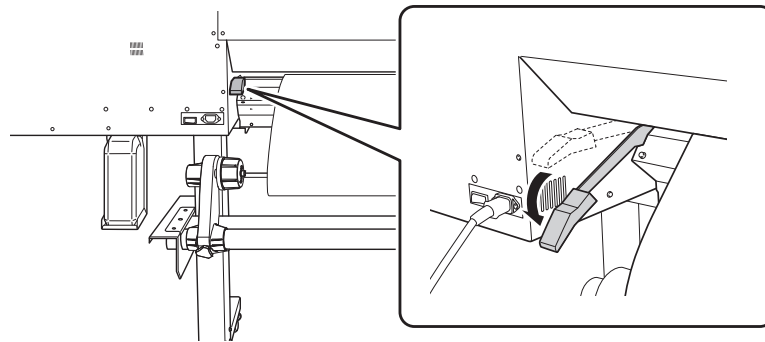

6. (Move to the front of the printer.) Gently hold down the media and raise the loading lever (front).

The media is released.

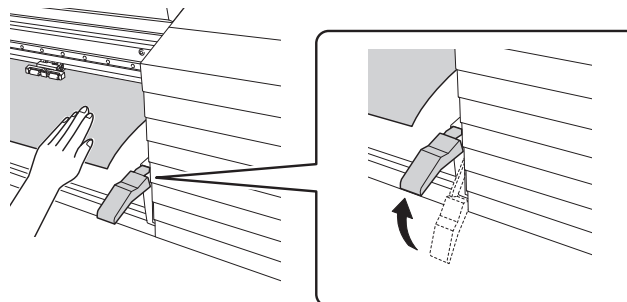

7. Straighten the media.

Align the media with the line indicated with the arrow in the following figure.

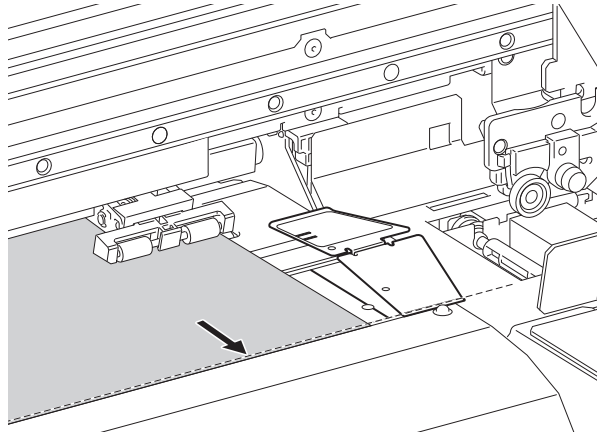

- 8.** Make sure the right edge of the media is in line with the guide line.

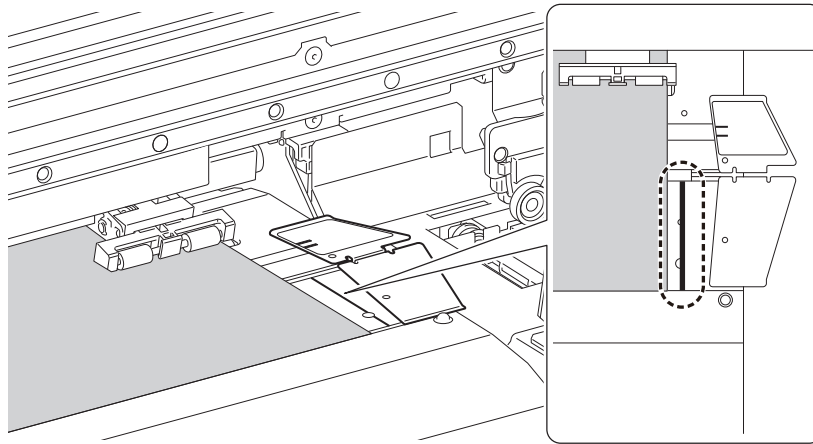

- 9.** Lower the loading lever (front).

The media is held in place.

At this time, the message "PRESS ENTER KEY TO SET UP" is displayed on the screen, but do not press [ENTER] yet, and proceed to the next step.

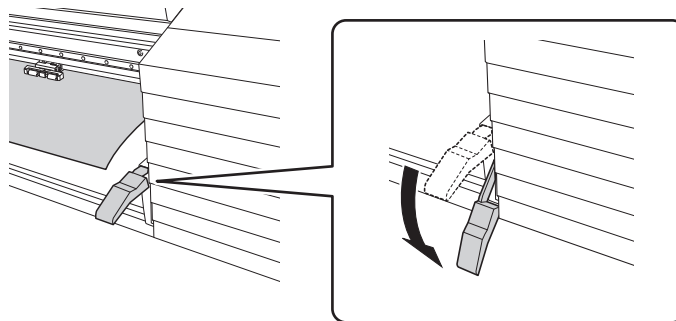

- 10.** Line up the edges of the media with the centers of the holes of the media clamps (left and right).

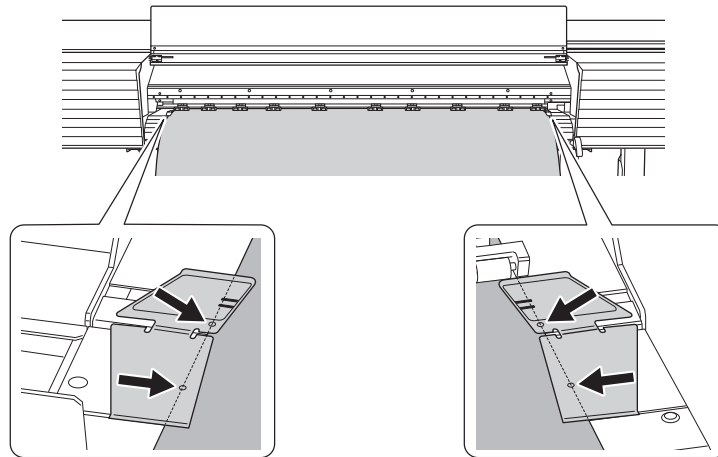

IMPORTANT

Be sure to use the media clamps when you load media.

If you attach the media clamps directly before printing after the media setup is complete, the machine may print on the media clamps.

MEMO

Press down on the bent part of the media clamps to lift up both of their edges. Move the media clamps to the left and right with both edges lifted up.

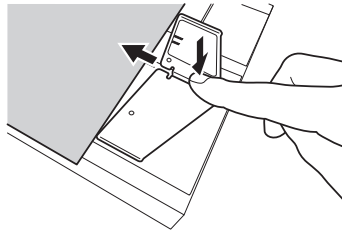

11. Close the front cover.

12. Press [ENTER].

When you press [ENTER], the print-head carriage moves and detects the width of the media. This operation is called initialization. When initialization ends, [SETUP] on the operation panel lights, and the printable width is displayed on the screen. This completes the setup of the media.

Separating the Media

Procedure

1. Close the front cover.
2. Check that [SETUP] is lit.
3. Press [FUNCTION].
4. Press [▼] several times to display the screen shown below.

```

FUNCTION  ◀▶
SHEET CUT  ↓
  
```

5. Press [ENTER].

When you press [ENTER], the media moves from position ① to a position above the separating line (②) and is separated.

If ① is obscured by the media clamp, use the two lines (③) on the media clamp as a guide.

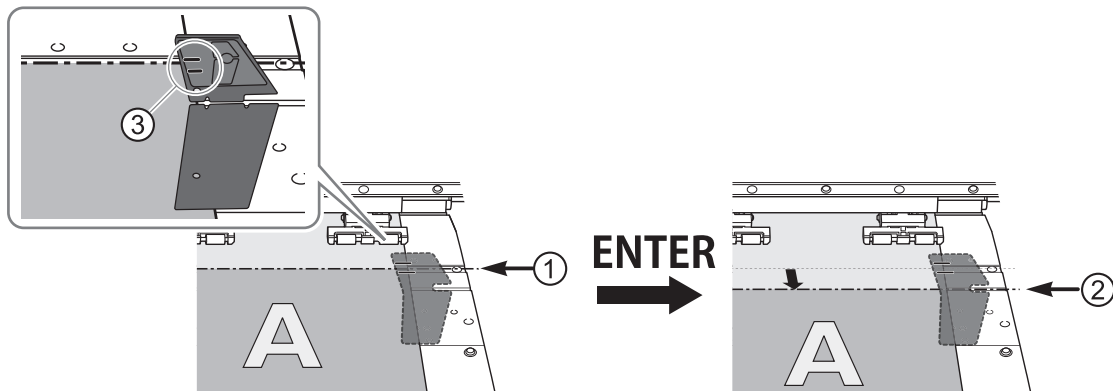

MEMO

You can configure settings in the software RIP for automatic media separation after output has finished. For information on how to configure the settings, refer to the documentation for the software RIP you are using.

IMPORTANT

Separation Operations

- When performing separation, do not use [▲] to pull the media back. If the distance from the end of the media to the separation location is short, separation may not be performed smoothly.

Give Attention to the Media Composition

- For some types of media, separation is not possible.
- Some types of media may remain on the platen after separation. If the media remains on the platen, remove it by hand.

What to Do First after Installation

Accurately Adjusting the Misalignment of the Ink Landing Position

This adjusts the misalignment of the ink landing position.
This adjustment must be performed in the following cases.

- When using this machine for the first time
- When changing the media to use
- When you have changed the print-head height
- When printing does not improve with "MEDIA GAP ADJ. SIMPLE SETTING"

Procedure

1. Press [MENU].
2. Press [▼] several times to display the screen shown below.

```
MENU ◀◆
MEDIA GAP ADJ. ▶
```

3. Press [▶], then [▲] to display the screen shown below.

```
MEDIA GAP ADJ. ◀◆
DETAIL SETTING ▶
```

4. Press [▶] to display the screen shown below.

```
DETAIL SETTING ◀◆
TEST PRINT ↵
```

5. Press [ENTER].

Printing of the test pattern starts.

6. When printing is finished, press [▼], then [▶] to display the screen shown below.

```
H1 H2 H3 ◀◆▶
 0 0 0 ↵
```

7. View the printed test pattern, and then determine the correction values from "MEDIA GAP ADJ. NO.1 H1" to "MEDIA GAP ADJ. NO.1 H4".

Select the value that gives the least misalignment between the two lines. In the case of the following figure, select "+5" for "H1" and "H3" and "+4" for "H2" and "H4". When you cannot choose between two sequential numbers, select a value that is between them (you can set correction values in units of "0.5").

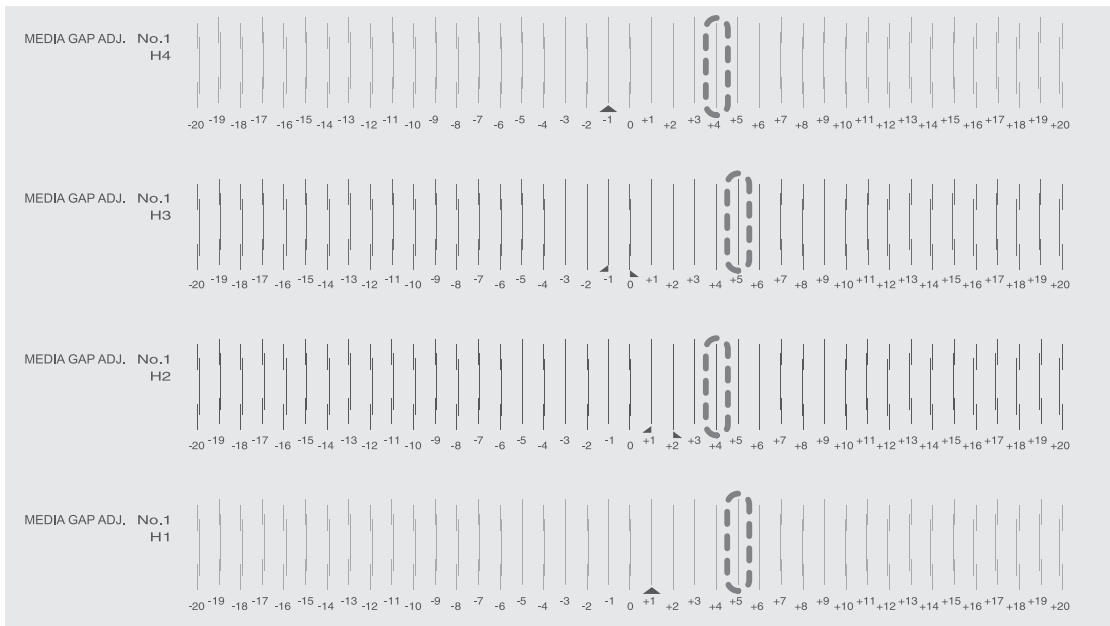

8. Set the correction values from "H1" to "H4".

- (1) Press [◀] or [▶] to select a value from "H1" to "H4".
- (2) Press [▲] or [▼] to select the correction value.

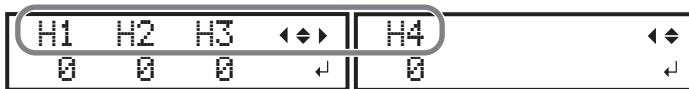

- (3) When you have finished setting the correction values, press [ENTER].

The screen shown below appears again.



9. Press [▼] to display the screen shown below.

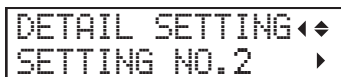

10. Set the correction values from "MEDIA GAP ADJ. NO.2 H1" to "MEDIA GAP ADJ. NO.2 H4" in the same manner as step 8.

11. Press [▼] to display the screen shown below.



12. Press [ENTER].

Printing of the test pattern starts.

13. Check the test pattern to see whether the correction was successful.

For all the correction values, check that the misalignment is minimized for the two vertical lines indicated by "▲" (that is, the current correction value). If the misalignment is smaller for another set of vertical lines, set the correction value again.

14. When you have successfully performed the correction, press [MENU] to go back to the original screen.

Checking before Output

LAN (Local Area Network) Settings

Check that you can perform communication through the LAN (Local Area Network).

The LAN is enabled if the status LED (②) on the LAN connector located on the side of the printer is lit in green.

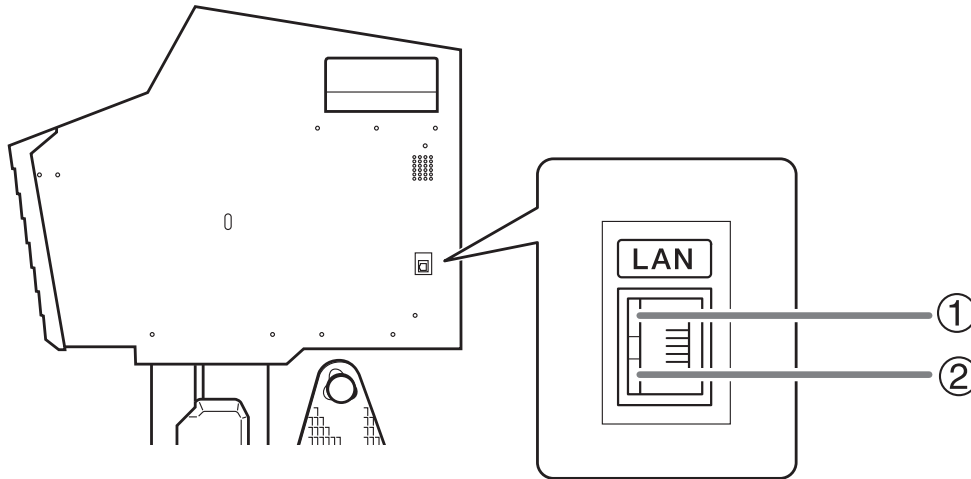

①	Activity LED	This flashes yellow while data is being received from the network.
②	Status LED	This indicates the status of the communication function. When it lights in green, communication is possible.

Preventing Sedimentation in Inks

The precipitation of the ingredients in the ink disables printing in normal color. To mix the ingredients in the ink well, remove the pouch tray, shake it 50 times (for approximately 20 seconds), and then reinsert it.

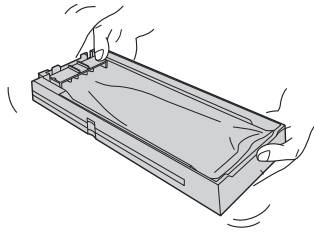

Shake the pouch trays:

- Once per week (for all the inks).
- After inserting a new ink pouch (for all the inks).
- Before starting the day's operations (for just the white ink).

MEMO

To prevent ink precipitation, you can make the machine periodically display a message prompting you to mix the ink.

- P. 119 "Thoroughly Mixing the Ink Periodically"

IMPORTANT

- The ingredients in white ink tend to settle. Allowing the ink to stand without shaking it can cause the settled material to harden, resulting in malfunction or other problems.
- Do not remove the ink pouches. Shake the entire pouch tray. Removing the ink pouches may lead to the ink leaking.
- Before shaking, wipe off any ink from around the mouth of the ink pouch. If you do not wipe off the ink, it may splatter when you shake the pouch tray.
- When you have finished mixing the ink, reinsert the pouch tray immediately. Taking time to reattach the ink cartridge will adversely affect the ink path.

Pausing and Canceling Output

You can pause and cancel output before it finishes.

Pausing and Resuming Output

IMPORTANT

We do not recommend resuming printing because horizontal stripes are produced at the place where printing was paused.

Procedure

- 1.** Press [PAUSE] before printing finishes.
This pauses the printing operation.
- 2.** Press [PAUSE] again.
The printing operation resumes.

Canceling Output

Procedure

1. Press [PAUSE] before printing finishes.
This pauses the printing operation.
2. When the screen shown below appears, hold down [PAUSE] for 1 second or longer.

```
TO CANCEL, HOLD  
DOWN PAUSE KEY
```

This cancels the printing operation.

3. Stop sending the output data from the computer.

Ink Pouch/TR2 Cleaning Liquid Pouch Replacement

Out-of-ink Warnings

If Using 8 Colors (CMYKLcLmLkW, CMYKLcLmLkOr, or CMYKLkOrGrW) or 7 Colors (CMYKLkOrGr)

When an ink pouch runs out, printing pauses and a warning beep sounds.

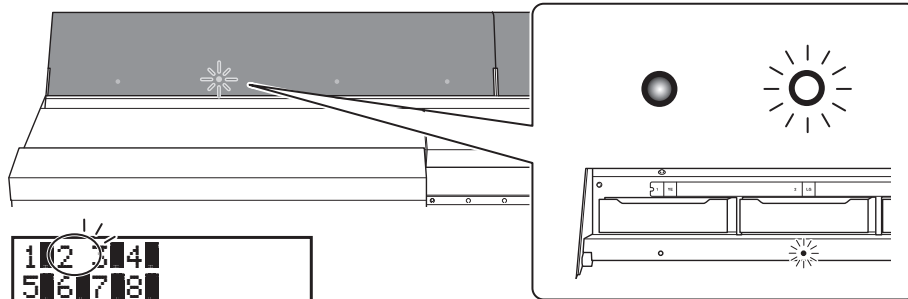

If an ink runs out, the numbers of the color that has run out flash.

Lit	Indicates that ink still remains
Flashing	Indicates that ink has run out

If Using 4 Colors (CMYK)

If one ink cartridge of the same color runs out, the machine continues printing using the other ink cartridge. When all the ink of the same color runs out, printing pauses and a warning beep sounds.

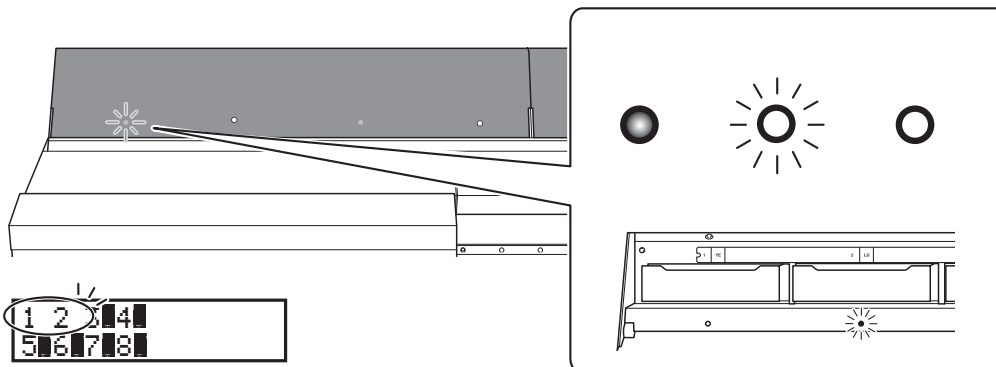

If both inks of the same color run out, the numbers of the color that has run out flash.

Lit	Indicates that ink still remains
Flashing	Indicates that ink has run out
Off	Indicates an ink pouch that is currently not in use

IMPORTANT

Never reuse an ink pouch when the machine shows a sign indicating no ink.

Occasionally the machine will show a sign indicating no ink even if there is a small amount of ink remaining in the pouch, but nevertheless do not use it. Such an ink pouch is in a state where drawing ink from it is impossible. Using it in such a state may force air into the ink path and cause printer malfunctions.

RELATED LINKS

- P. 48 "Ink Pouch Replacement"

Out-of-TR2-cleaning-liquid Warnings

If the TR2 cleaning liquid runs out, the cleaning liquid slot light flashes. After some time, a message requesting that you replace the TR2 cleaning liquid will be displayed on the screen.

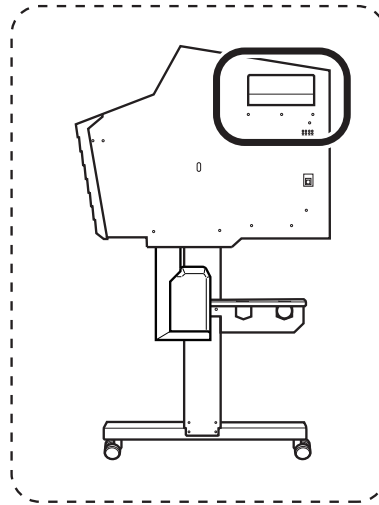
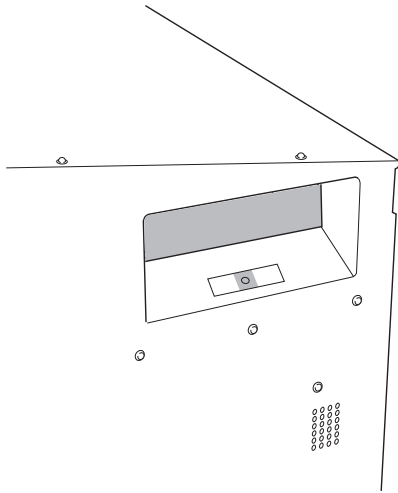

```
CHANGE CL-LIQUID
FOR WIPER↵
```

"CL-LIQUID FOR WIPER" indicates the TR2 cleaning liquid.

RELATED LINKS

- P. 50 "TR2 Cleaning Liquid Pouch Replacement"

Ink Pouch Replacement

⚠ WARNING Never store ink, cleaning liquid, or discharged fluid in any of the following locations.

- Any location exposed to open flame
- Any location where high temperature may occur
- Near bleach or any other such oxidizing agent or explosive material
- Any location within the reach of children

Fire may be a danger. Accidental ingestion by children may pose a health hazard.

IMPORTANT

Precautions regarding ink pouch replacement

- Be sure to replace each pouch with an item of identical type and color.
- Never use an ink pouch that has already been used in another machine even if it is an identical type.
- Never mix different types of items.
- Never leave the machine with a pouch tray removed. The print heads may become clogged.
- Do not insert or remove pouch trays unless necessary. Ink may leak.
- Take care not to drop ink pouches.

Procedure

1. Open the ink slot cover.

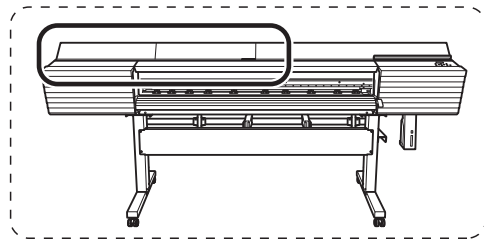
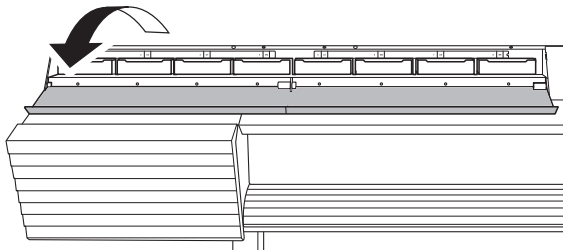

2. Remove the pouch tray for the color that you will replace.

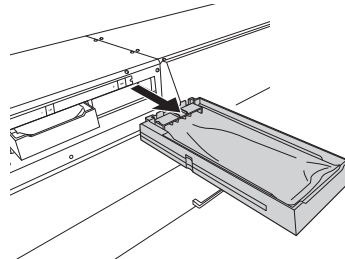

3. Remove the ink pouch from the pouch tray.

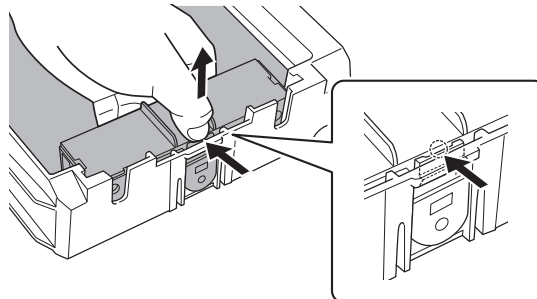

4. Set the new ink pouch in the pouch tray.

Check that the hook (①) has caught on the edge.

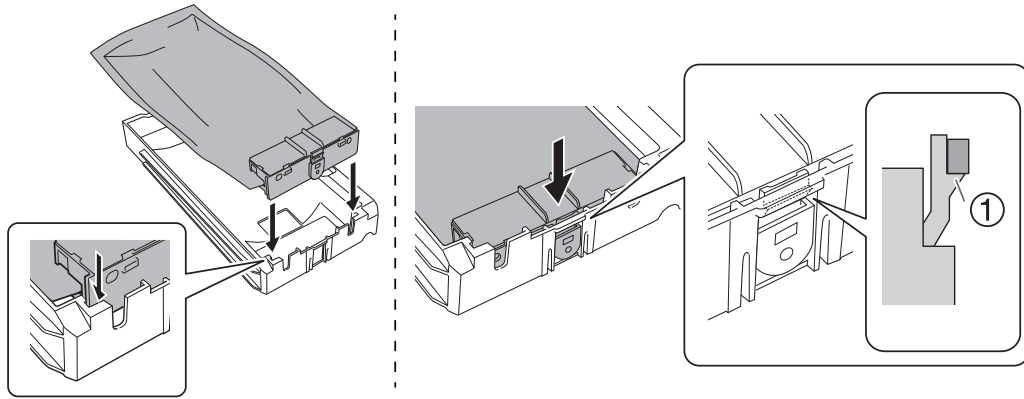

5. Gently shake the new ink pouch.

During storage, the ink components may have precipitated. When replacing an ink pouch, gently shake the new ink pouch to mix its contents before setting the ink pouch in the tray.

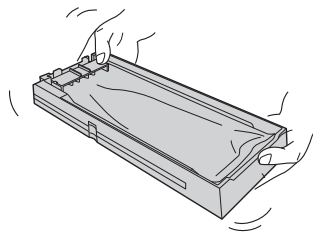

IMPORTANT

Never reuse an ink pouch when the machine shows a sign indicating no ink.

Occasionally the machine will show a sign indicating no ink even if there is a small amount of ink remaining in the pouch, but nevertheless do not use it. Such an ink pouch is in a state where drawing ink from it is impossible. Using it in such a state may force air into the ink path and cause printer malfunctions.

6. Set the pouch tray in the ink slot.

Insert the pouch tray as far as it will go.

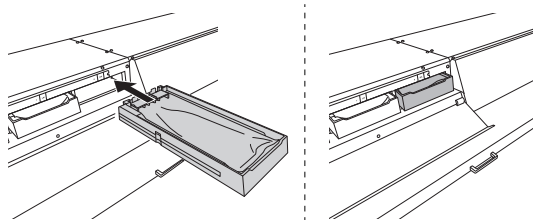

IMPORTANT

- Do not insert empty pouch trays. Doing so may force air into the ink path and cause printer malfunctions.
- Check the color names indicated on the ink slots and the ink pouches to set all the pouch trays in their correct positions. Insert the pouch trays as far as they will go.

7. Close the ink slot cover.

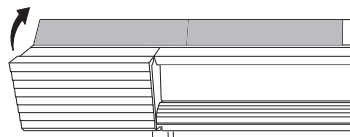

TR2 Cleaning Liquid Pouch Replacement

⚠ WARNING Never store ink, cleaning liquid, or discharged fluid in any of the following locations.

- Any location exposed to open flame
- Any location where high temperature may occur
- Near bleach or any other such oxidizing agent or explosive material
- Any location within the reach of children

Fire may be a danger. Accidental ingestion by children may pose a health hazard.

Procedure

1. Remove the pouch tray from the cleaning liquid slot.

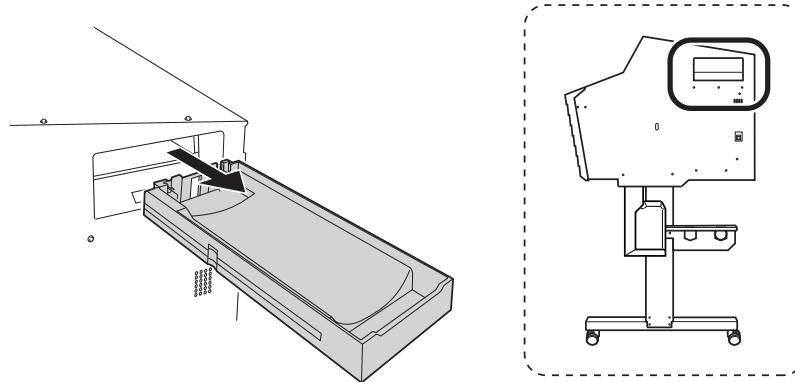

2. Remove the TR2 cleaning liquid pouch from the pouch tray.

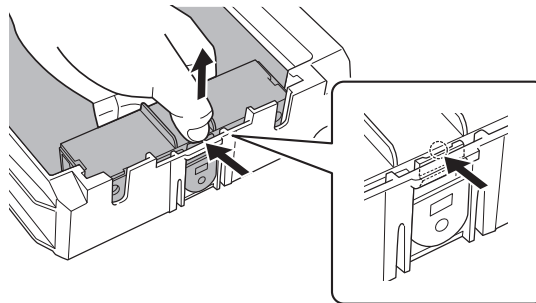

3. Set the new TR2 cleaning liquid pouch in the pouch tray.

Check that the hook (①) has caught on the edge.

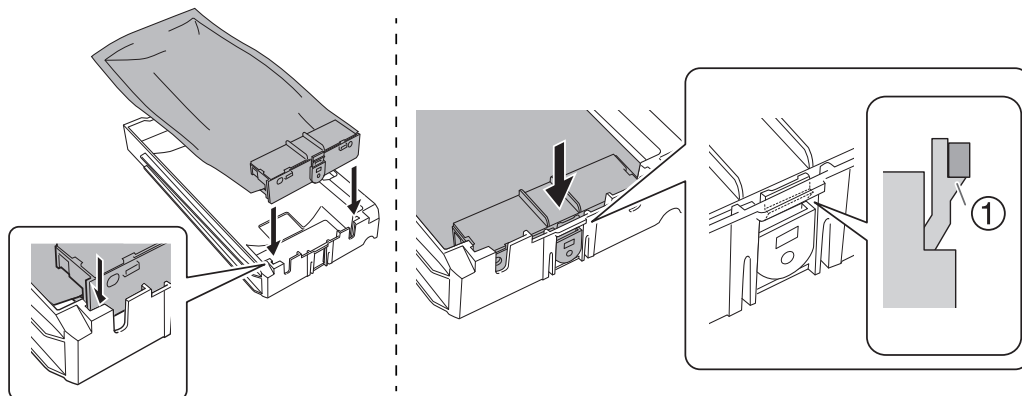

4. Set the pouch tray in the cleaning liquid slot.

Insert the pouch tray as far as it will go.

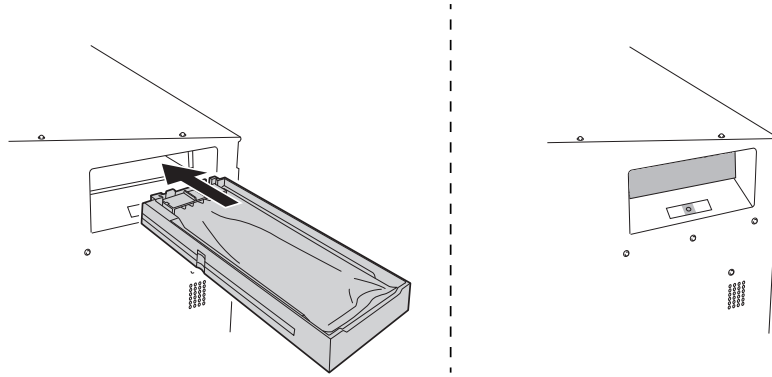

Output Method

Printing Method

Preparations before Printing Output.....	54
Printing Tests and Normal Cleaning	54
Printing Output	57
Step 1: Batch Settings for Printing.....	57
Step 2: Starting Output.....	66

Preparations before Printing Output

Printing Tests and Normal Cleaning

1. Perform a printing test.

Before you carry out actual printing, perform a printing test to ensure no dot drop-out or dot displacement occurs. If dot drop-out or dot displacement occurs, perform cleaning of the print heads (normal cleaning).

MEMO

When performing printing tests successively, you can select "FEED" (vertical printing) or "SCAN" (horizontal printing) as the print position for the second and later tests in comparison to the first test.

Procedure

1. Load the media.
P. 28 "Setup of Media"
2. Press [FUNCTION].
3. Press [▼], then [▶] to display the screen shown below.



4. Press [ENTER].
Printing of the test pattern starts.
5. Check whether there is dot drop-out or dot displacement in the test pattern.
Missing blocks indicate dot drop-out. Collapsed or inclined blocks indicate dot displacement.

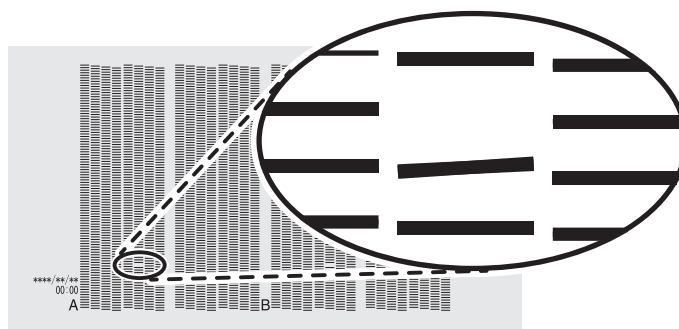

6. If you have opened the front cover, close it.
If no dot drop-out or dot displacement occurs, this operation is finished. Press [FUNCTION] to go back to the original screen.

RELATED LINKS

- P. 111 "Performing Printing Tests Arranged Horizontally"

2. Perform normal cleaning.

Procedure

1. Press [▼] to display the screen shown below.

```
CLEANING  ◀◆▶
NORMAL CL. ▶
```

2. Check for the group with dot drop-out or dot displacement by viewing the results of the printing test. The space from "A" to "B" is group A. The space from "B" to the right side is group B.

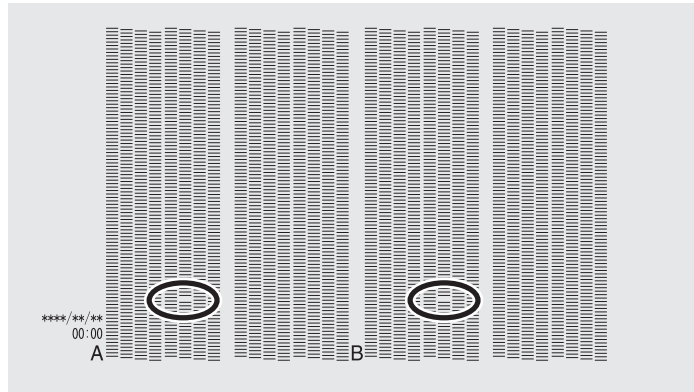

MEMO

If the printing-test results are difficult to interpret

Check the results in a bright location, changing your line of vision. They are visible using the reflection of the light.

3. Press [▶].
4. Select the group of print heads to clean.
 - (1) Press [◀] or [▶] to select the group of print heads that is not to be cleaned.

```
NORMAL CL.  ◀◆▶
AB          ◀
```

- (2) Press [▲] or [▼] to get rid of the group display.

```
NORMAL CL.  ◀◆▶
A           ◀
```

- (3) Repeat steps 1 and 2 to display only the group of print heads that requires cleaning.

Only the displayed groups will be cleaned. If "AB" is displayed, both groups will be cleaned.

5. Press [ENTER] to confirm your entry.

The screen shown below appears, and then cleaning starts. The (approximate) remaining time for the procedure is displayed on the screen. (The display shown below is an example. "01:45" = "1 minute and 45 seconds")

```
CLEANING...
>>          01:45
```

When finished, the screen shown below appears again.

```
NORMAL CL.  ◀◆▶
AB          ◀
```

6. Press [◀] several times to display the screen shown below.

```
CLEANING  ◀◆
NORMAL CL. ▶
```

7. Press [▲] to display the screen shown below.

```
CLEANING  ◀◆
TEST PRINT ↵
```

8. Press [ENTER].

Perform a printing test again to check whether the dot drop-out and dot displacement have been corrected.

9. Check to make sure the dot drop-out or dot displacement has been corrected.

If the problem persists, try performing normal cleaning again. If the printer has been used for a long period, dot drop-outs may not be fixed even after performing normal cleaning two or three times. If this is the case, clean using a different method.

RELATED LINKS

- P. 140 "When Normal Cleaning Is Not Effective"
-

Printing Output

Step 1: Batch Settings for Printing

To ensure the optimal output according to the media size and type, you can configure various settings on this machine. However, it is hard work to configure these settings one at a time. You can use the "MEDIA SETTING" menu to configure the absolute minimum of necessary items as a batch. You can save the setting details as a preset.

Note that you can set all the items set here individually as well.

1. Start the "MEDIA SETTING" menu.

Procedure

1. Load the media.

Check that the media is not sagging. If any sagging exists, settings such as the correction values will not function effectively.

● P. 28 "Setup of Media"

2. Press [MENU].

3. Press [ENTER].



If you want to cancel the batch settings before they are completed, see the following page.

RELATED LINKS

- P. 65 "Canceling Batch Settings before They Are Completed"

2. Set the print heater and dryer temperatures.

Procedure

1. Press [▲] or [▼] to set the temperature for "HEATER".
Recommended temperature: 40°C (104°F)

```
PRINT HEATER  ◆
 30°C ▶ 40°C  ↵
```

2. Press [ENTER] to confirm your entry.
3. Press [▲] or [▼] to set the temperature for "DRYER".
Recommended temperature: 45°C (113°F)

```
DRYER  ◆
 30°C ▶ 45°C  ↵
```

4. Press [ENTER] to confirm your entry.

3. Adjust the print head height.

Procedure

1. Press [◀] to select "CHANGE".

```

HEAD HGT LOW  ◀▶
[CHANGE] NEXT  ↵
    
```

2. Press [ENTER] to confirm your entry.

You can select "NEXT" and press [ENTER] to skip the current menu and proceed to the next menu.

3. When the following screen is displayed, open the front cover.

```

HEAD HEIGHT
LOW  ▶  LOW  ↵
    
```

4. Move the height-adjustment lever to adjust the head height.

When you change the position of the height-adjustment lever, the display screen changes and the buzzer sounds at the same time.

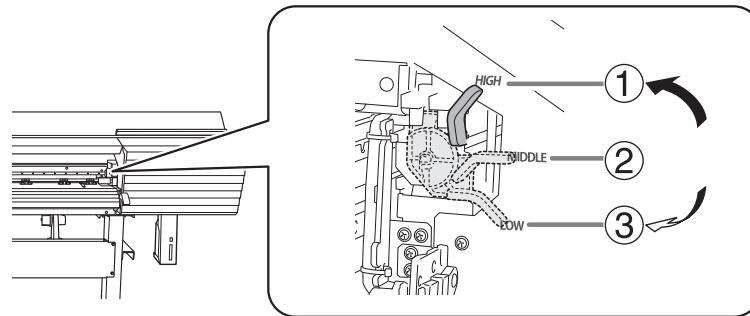

	Position	Display screen
①	HIGH	<pre> HEAD HEIGHT LOW ▶ HIGH ↵ </pre>
②	MIDDLE	<pre> HEAD HEIGHT LOW ▶ MIDDLE ↵ </pre>
③	LOW	<pre> HEAD HEIGHT LOW ▶ LOW ↵ </pre>

MEMO

- Normally move the height-adjustment lever to "LOW". For media that is wrinkled or comes loose from the platen during printing, move the height-adjustment lever to "MID" or "HIGH".
- The printing quality degrades as the distance between the media and the print heads increases. Do not move the height-adjustment lever to "MID" or "HIGH" needlessly.

5. Close the front cover.

4. Perform position adjustment of the feed direction (reduce horizontal stripes).

Feed direction means the feed direction of the media. Perform the correction adjusting to the media in advance because horizontal strips are more likely to occur during printing when the movement distance of the media changes subtly depending on the media's thickness.

Procedure

1. Press [◀] to select "YES".

```

CALIBRATION  ◀▶
[SET]  NEXT  ↵
    
```

2. Press [ENTER] to confirm your entry.

Printing of the test pattern starts.

You can select "NEXT" and press [ENTER] to skip the current menu and proceed to the next menu.

3. Press [ENTER].

```

INPUT
  ADJ. VALUES ↵
    
```

4. View the printed test pattern, and then determine the correction value.

The current correction value (①) is that of the figure indicated by "▲." Select the value to make the gap (②) and overlap (③) between the upper/lower squares smallest. In the case of the following figure, select "-0.40." (④). When you cannot choose between two sequential numbers, specify a value that is between them.

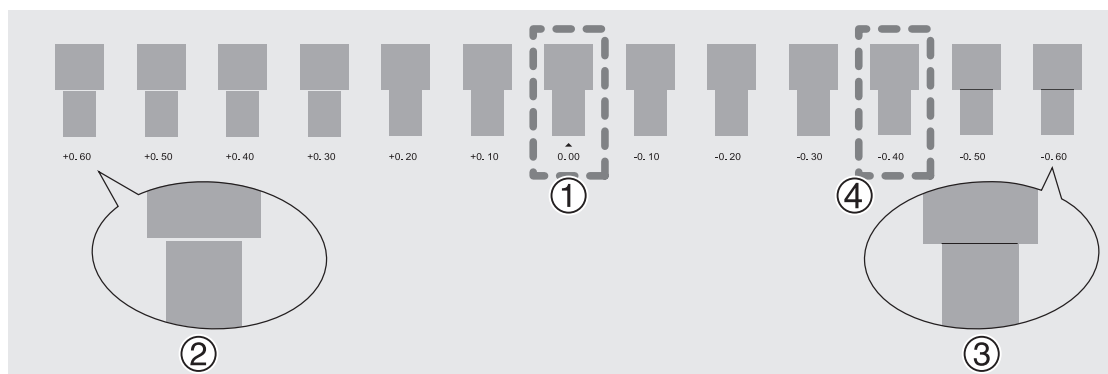

5. Press [▲] or [▼] to select the correction value.

```

CALIBRATION  ▲
  0.00% ▶+0.05% ↵
    
```

6. Press [ENTER] to confirm your entry.

7. Press [◀] to select "YES".

```

REDO ADJ.?  ◀▶
[YES]  DONE  ↵
    
```

8. Press [ENTER] to confirm your entry.

The test pattern is printed again. Check that the gap and overlap are the smallest for the figure indicated by "▲" (that is, the current correction value). If the gap and overlap are smaller for another figure, return to step 5. to perform the setting again.

If you do not need to change the correction value, press [ENTER] again.

9. Press [▶] to select "DONE".

```
REDO ADJ.?  ◀▶  
YES  [DONE]  ↵
```

10. Press [ENTER] to confirm your entry.

5. Adjust the misalignment of the ink landing position.

Procedure

1. Press [◀] to select "YES".

```
MEDIA GAP ADJ. ◀▶
[SET]  NEXT      ↵
```

2. Press [ENTER] to confirm your entry.

Printing of the test pattern starts.

You can select "NEXT" and press [ENTER] to skip the current menu and proceed to the next menu.

3. Press [ENTER].

```
INPUT
  ADJ. VALUES ↵
```

4. View the printed test pattern, and then determine the correction value.

Select the value that gives the least misalignment between the two lines. In the case of the following figure, select "-3." When you cannot choose between two sequential numbers, select a value that is between them (you can set correction values in units of "0.5").

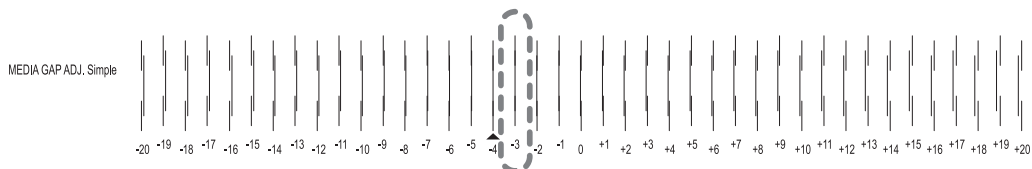

5. Press [▲] or [▼] to select the correction value.

```
MEDIA GAP ADJ. ◆
  0 ▶      5  ↵
```

6. Press [ENTER] to confirm your entry.

7. Press [◀] to select "YES".

```
REDO ADJ.? ◀▶
[YES]  DONE  ↵
```

8. Press [ENTER] to confirm your entry.

The test pattern is printed again. Check that the misalignment is minimized for the two vertical lines indicated by "▲" (that is, the current correction value). If the difference between the two vertical lines is smaller in other locations, return to step 5 to configure the setting again.

If you do not need to change the correction value, press [ENTER] again.

9. Press [▶] to select "DONE".

```
REDO ADJ.? ◀▶
  YES  [DONE] ↵
```

10. Press [ENTER] to confirm your entry.

6. Set the drying method and time after printing.

Procedure

1. Press [▲] or [▼] to select "ENABLE" or "DISABLE".

Set whether the media should be fed until the trailing edge of the printed area is put on the dryer after the 1st page is printed. To make sure to dry the entire printed area, select "ENABLE". If "DISABLE" is selected, the trailing edge of the printing area is not fed to the dryer unless you continue with a subsequent printing operation.

```
FEED FOR DRY  ◆
DISABLE▶ENABLE  ↵
```

2. Press [ENTER] to confirm your entry.

3. Press [▲] or [▼] to set the drying time.

Set the drying time after the 1st page is printed. The next operation is not started until the set time passes.

```
DRYING TIME  ◆
10min ▶10min  ↵
```

MEMO

- When the drying time has been set in the software RIP, priority is given to the software RIP's setting.
- Example of setting time (general guide)
The setting time varies according to the settings such as the type of media and the printing quality.
 - Condition Non-coated vinyl chloride media
 - Setting time: About three minutes

4. Press [ENTER] to confirm your entry.

7. Save the settings as a preset.

Procedure

1. Press [◀] to select "SAVE".

```
PRESET          ◀▶
[SAVE]  NEXT    ↵
```

2. Press [ENTER] to confirm your entry.

If you select "NEXT" and press [ENTER], the screen in step 7 is displayed, and the settings you have selected up to this point are not saved as a preset. However, they will remain as the current setting values for the machine.

3. Press [▲] or [▼] to select a destination to save the preset.

You can select a name from NAME1 to NAME8.

```
SAVE TO        ◆
NAME1          ↵
```

4. Press [ENTER] to confirm your entry.

5. Set the name.

- (1) Press [▲] or [▼] to select a character.
- (2) Press [▶] to move to the next character.
- (3) Set the following characters in the same way.

You can enter up to 15 characters.

```
SET NAME      ◀◆
              ↵
```

6. Press [ENTER] to confirm your entry.

7. Press [MENU] to go back to the original screen.

```
COMPLETED
```

This completes the operation of the "MEDIA SETTING" menu.

Canceling Batch Settings before They Are Completed

Procedure

1. Press [MENU] during setup.
2. Press [◀] to select "YES".

```
QUIT SETTING  ◀▶  
[YES]  NO      ↵
```

3. Press [ENTER] to confirm your entry.

The screen shown below appears again.

```
MENU          ◀◆  
MEDIA SETTING ↵
```

Selecting "NO" in step 2 returns you to the screen that was displayed when you pressed [MENU].

MEMO

Even if you cancel "MEDIA SETTING" before they are completed, the values set so far will be saved.

Step 2: Starting Output

- ⚠ CAUTION** Never touch the print-head carriage while output is in progress. The print-head carriage moves at high speed. Coming into contact with the moving carriage may cause injury.

Procedure

- In the case of output for the first time on that day, shake the white ink pouch tray. Remove just the pouch tray for the white ink, shake the pouch tray 50 times (about 20 seconds), and then reinsert this pouch tray. The precipitation of the ingredients in the ink disables printing in normal color. So that the ink mixes well, shake the pouch tray horizontally with a stroke length of around 5 cm (2 in.) from each end of the tray.

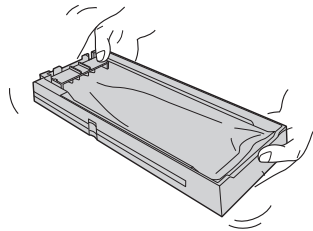

IMPORTANT

- Shake all the pouch trays, including the pouch tray for the white ink, once per week.
- Do not remove the ink pouches. Shake the entire pouch tray. Removing the ink pouches may lead to the ink leaking.
- Before shaking, wipe off any ink from around the mouth of the ink pouch. If you do not wipe off the ink, it may splatter when you shake the pouch tray.
- When you have finished mixing the ink, reinsert the pouch tray immediately. Taking time to reattach the ink cartridge will adversely affect the ink path.

- Close the front cover.

- Check that [SETUP] is lit.

If [SETUP] is not lit, the setup is not completed. Lower the loading lever, and then press [ENTER].

- Wait until [HEATER] stops flashing and stays lit.

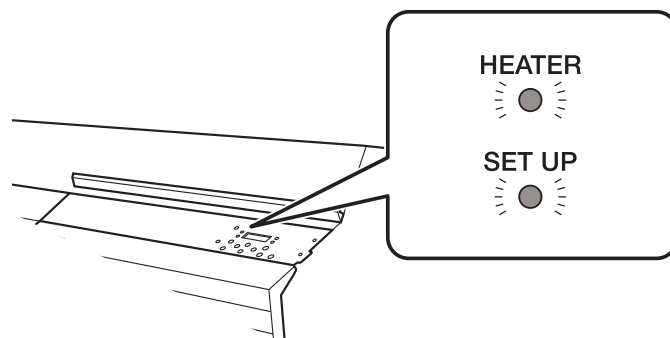

- Check that the screen shown below (the top menu) is displayed.

If the top menu is not displayed, press [MENU].



- Send the output data from the computer.

For information on how to create the output data, refer to the documentation for the software RIP.

MEMO

When you send the output data, "FILLING LIQUID.." or "CLEANING..." may be displayed on the screen. These indicate the preparation operations performed before output. Output will begin after the time displayed on the screen elapses.

IMPORTANT**Output Is Not Possible in These Situations**

- The machine does not run when a cover (front, left, right, or ink slot) is open.
- Data from the computer is not accepted when [SETUP] is dark.
- Printing does not start until [HEATER] lights. However, in the following cases printing is possible even if [HEATER] is not lit.
 - "PRINT" and "DRYER" are set to "OFF"
 - "POWER" in the heater settings is set to "OFF"
- Data from the computer is not accepted when you are not at the top menu.

Points that must be observed

- Never open a cover (front, left, or right) while output is in progress. Doing so interrupts printing.
- When you are performing printing, clamp the edges of the media with the media clamps. Otherwise, the edges of the media may warp and catch on the print heads.
- During output, do not touch the media. Doing so may obstruct the media feed or cause the media to rub against the print heads, which may result in a paper jam or damage to the heads.
- Keep the loading lever raised when the machine is not in use.

When not using the machine, remove any media and store it in a suitable environment.

- If the machine is left with the media loaded, the media may be damaged, which may adversely affect printing. When not using the machine, remove any media and store it in a suitable environment.

RELATED LINKS

- P. 87 "Setting the Print Heater Temperature"
- P. 88 "Setting the Dryer Temperature"
- P. 93 "Switching Off the Print Heater and Dryer Together"

Optimizing Quality and Ef- ficiency

Optimizing the Output Quality

Using the Correction Functions.....	70
Adjusting the Misalignment of the Ink Landing Position	70
Accurately Adjusting the Misalignment of the Ink Landing Position.....	72
Reducing Horizontal Bands (Feed Correction Function).....	75
Configuring Settings to Match the Properties of the Media	77
Changing the Print Head Height	77
Using Transparent Media	79
Using Hard-to-Dry Media	82
Using Media That Wrinkles Easily/Does Not Move Smoothly	83
Using Sticky Media	84
Preventing Ink Discharge Issues	85
Preventing Soiling of the Media, Dot Drop-out, and Dot Displacement.....	85
Adjusting the Ink-drying Method	86
What Is the Media Heating System?	86
Setting the Print Heater Temperature	87
Setting the Dryer Temperature.....	88
Hints and Tips for Temperature Control	89
Setting the Temperature during Preheating.....	90
Drying the Trailing Edge of the Printing Area on the Dryer	91
Setting the Drying Time after Printing	92
Switching Off the Print Heater and Dryer Together.....	93
Using an Auxiliary Drying Unit.....	94
Using a Blower-fan Unit	95

Using the Correction Functions

To optimize the output quality, it is effective to use some correction functions.

Adjusting the Misalignment of the Ink Landing Position

This adjusts the landing position of the ink discharged from the print heads. The landing position varies according to the print head height and the thickness of the media, so we recommend that you make corrections to match the media you are using.

First, print a test pattern, and then determine and enter the correction value. After entering the correction value, print a test pattern again and check the correction results.

Procedure

1. Press [MENU].
2. Press [▼] several times to display the screen shown below.

```
MENU ◀◆
MEDIA GAP ADJ. ▶
```

3. Press [▶] to display the screen shown below.

```
MEDIA GAP ADJ. ◀◆
TEST PRINT ↵
```

4. Press [ENTER].

Printing of the test pattern starts.

5. When printing is finished, press [▼], then [▶] to display the screen shown below.

```
SIMPLE SETTING ◀◆
  0 ▶ 0 ↵
```

6. View the printed test pattern, and then determine the correction value.

Select the value that gives the least misalignment between the two lines. In the case of the following figure, select "-3." When you cannot choose between two sequential numbers, select a value that is between them (you can set correction values in units of "0.5").

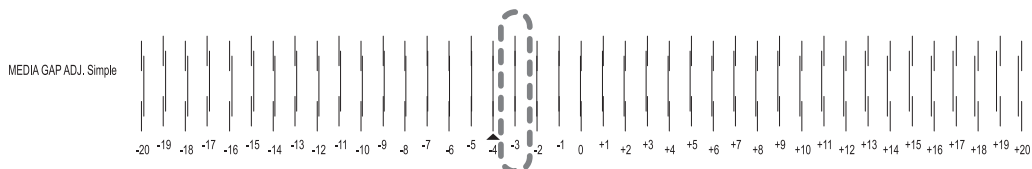

7. Press [▲] or [▼] to select the correction value.
 8. Press [ENTER] to confirm your entry.
 9. Press [◀] or [▶] to display the screen shown below.
- ```
MEDIA GAP ADJ. ◀◆
TEST PRINT ↵
```
10. Press [ENTER].
  11. Check the test pattern to see whether the correction was successful.

Printing of the test pattern starts.

Check that the misalignment is minimized for the two vertical lines indicated by "▲" (that is, the current correction value). If the misalignment is smaller for another set of vertical lines, set the correction value again.

- 12.** When you have successfully performed the correction, press [MENU] to go back to the original screen.



## Accurately Adjusting the Misalignment of the Ink Landing Position

This adjusts the landing position of the ink discharged from the print heads. You can make adjustments more accurately than "MEDIA GAP ADJ. SIMPLE SETTING". The landing position varies according to the print head height and the thickness of the media, so we recommend that you make corrections to match the media you are using.

First, print a test pattern, and then determine and enter the correction value. After entering the correction value, print a test pattern again and check the correction results.

This adjustment must be performed in the following cases.

- When using this machine for the first time
- When changing the media to use
- When you have changed the print-head height
- When printing does not improve with "MEDIA GAP ADJ. SIMPLE SETTING"

### Procedure

1. Press [MENU].
2. Press [▼] several times to display the screen shown below.

```
MENU ◀▶
MEDIA GAP ADJ. ▶
```

3. Press [▶], then [▲] to display the screen shown below.

```
MEDIA GAP ADJ. ◀▶
DETAIL SETTING ▶
```

4. Press [▶] to display the screen shown below.

```
DETAIL SETTING ◀▶
TEST PRINT ↵
```

5. Press [ENTER].

Printing of the test pattern starts.

6. When printing is finished, press [▼], then [▶] to display the screen shown below.

```
H1 H2 H3 ◀▶▶
 0 0 0 ↵
```

7. View the printed test pattern, and then determine the correction values from "MEDIA GAP ADJ. NO.1 H1" to "MEDIA GAP ADJ. NO.1 H4".

Select the value that gives the least misalignment between the two lines. In the case of the following figure, select "+5" for "H1" and "H3" and "+4" for "H2" and "H4". When you cannot choose between two sequential numbers, select a value that is between them (you can set correction values in units of "0.5").

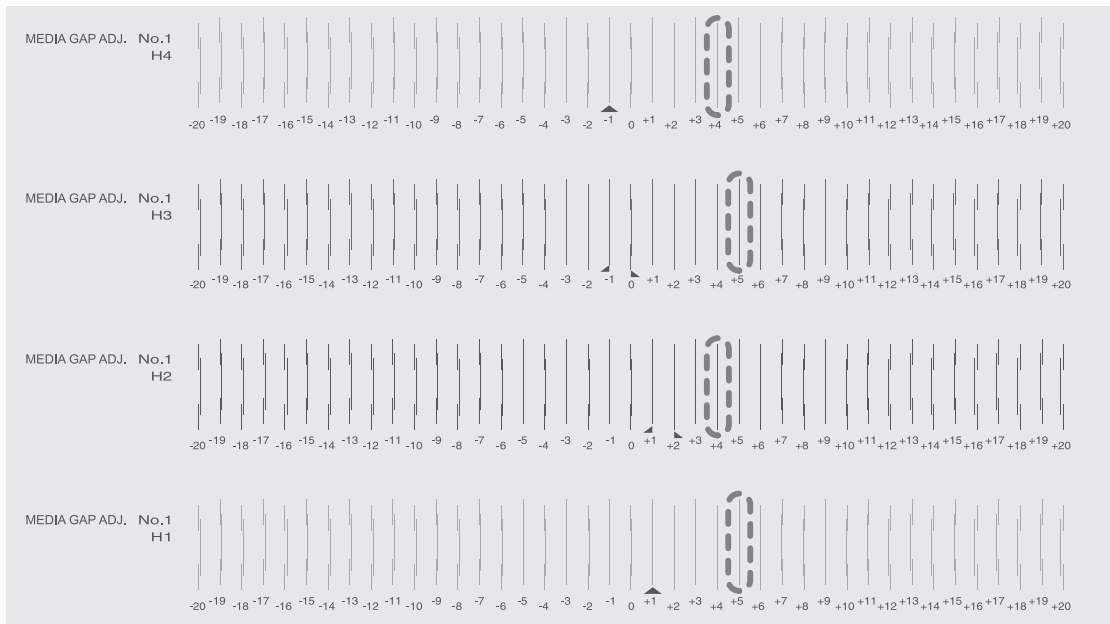

**8.** Set the correction values from "H1" to "H4".

- (1) Press [◀] or [▶] to select a value from "H1" to "H4".
- (2) Press [▲] or [▼] to select the correction value.

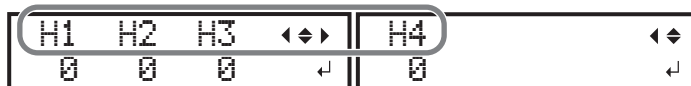

- (3) When you have finished setting the correction values, press [ENTER].

The screen shown below appears again.



**9.** Press [▼] to display the screen shown below.



**10.** Set the correction values from "MEDIA GAP ADJ. NO.2 H1" to "MEDIA GAP ADJ. NO.2 H4" in the same manner as step 8.

**11.** Press [▼] to display the screen shown below.



**12.** Press [ENTER].

Printing of the test pattern starts.

**13.** Check the test pattern to see whether the correction was successful.

For all the correction values, check that the misalignment is minimized for the two vertical lines indicated by "▲" (that is, the current correction value). If the misalignment is smaller for another set of vertical lines, set the correction value again.

**14.** When you have successfully performed the correction, press [MENU] to go back to the original screen.

RELATED LINKS

---

- P. 70 "Adjusting the Misalignment of the Ink Landing Position"
-

## Reducing Horizontal Bands (Feed Correction Function)

Perform corrections to make the band-shaped "stripes" on the printed surface less noticeable.

The band-shaped "stripes" are called "horizontal bands" or "banding." Horizontal bands are caused by the subtle changes in the movement distance that occur when feeding the media depending on the media's thickness and the temperature of the dryer. We recommend that you make corrections to match the media you are using and the set temperature of the dryer.

First, print a test pattern, and then determine and enter the correction value. After entering the correction value, print a test pattern again and check the correction results. Repeat the process of printing a test pattern and entering a correction value several times to find the optimal correction value.

### Procedure

1. If using roll media, check that the media is not sagging.
2. Press [MENU].
3. Press [▼] several times to display the screen shown below.

```
MENU ◀◆
CALIBRATION ▶
```

4. Press [▶] to display the screen shown below.

```
CALIBRATION ◀◆
TEST PRINT ◀
```

5. Press [ENTER].

Printing of the test pattern starts.

6. When printing of the test pattern is finished, press [▼], then [▶] to display the screen shown below.

```
SETTING ◀◆
0.00% ▶ 0.00% ◀
```

7. View the printed test pattern, and then determine the correction value.

The current correction value (①) is that of the figure indicated by "▲." Select the value to make the gap (②) and overlap (③) between the upper/lower squares smallest. In the case of the following figure, select "-0.40" (④). When you cannot choose between two sequential numbers, specify a value that is between them.

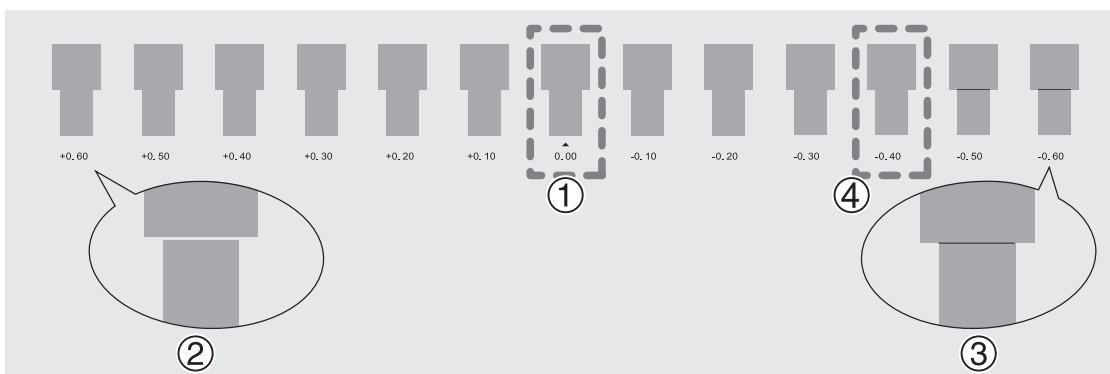

8. Press [▲] or [▼] to select the correction value.

```
SETTING ◀◆
0.00% ▶ -0.40% ◀
```

9. Press [ENTER] to confirm your entry.
10. Press [◀] or [▼] to display the screen shown below.

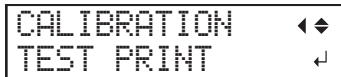

```
CALIBRATION ◀◆
TEST PRINT ▶◆
```

**11.** Press [ENTER].

Printing of the test pattern starts.

**12.** Check the test pattern to see whether the correction was successful.

Check that the gap and overlap are the smallest for the figure indicated by "▲" (that is, the current correction value). If the gap and overlap are smaller for another figure, set the correction value again.

**13.** When you have successfully performed the correction, press [MENU] to go back to the original screen.

**MEMO**

Depending on the software RIP you are using, you can also configure this setting in the software RIP (by, for example, choosing the media type). When you have made the setting in the software RIP, the software RIP's setting is used and the printer's setting is ignored.

# Configuring Settings to Match the Properties of the Media

## Changing the Print Head Height

This adjusts the print head height when printing on thick media and to prevent media that is wrinkled or comes loose from the platen from contacting the print heads.

You can select the print head height from "LOW", "MID" or "HIGH". Printing quality when the print head height is set to "MID" or "HIGH" may be coarser or otherwise lower than when set to "LOW".

### Procedure

1. Press [MENU].
2. Press [▼] several times to display the screen shown below.

```
MENU ◀▶
HEAD HEIGHT ▶
```

3. Press [▶]. After "NOW PROCESSING.." is displayed, the screen shown below appears.

```
HEAD HEIGHT ◀
HIGH ▶ LOW ↵
```

4. Open the front cover.
5. Move the height-adjustment lever to adjust the head height.

When you change the position of the height-adjustment lever, the display screen changes and the buzzer sounds at the same time.

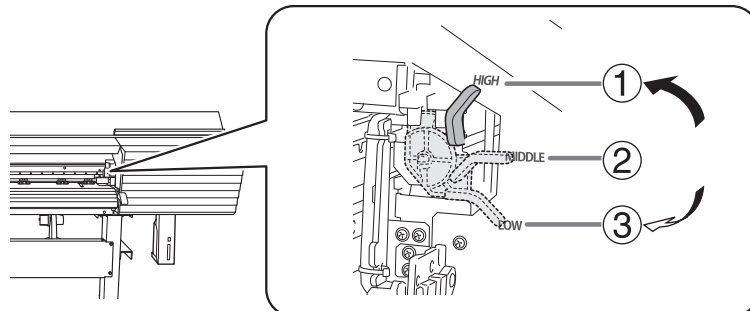

|   | Position | Display screen                          |
|---|----------|-----------------------------------------|
| ① | HIGH     | <pre>HEAD HEIGHT LOW ▶ HIGH ↵</pre>     |
| ② | MIDDLE   | <pre>HEAD HEIGHT ◀ LOW ▶ MIDDLE ↵</pre> |
| ③ | LOW      | <pre>HEAD HEIGHT LOW ▶ LOW ↵</pre>      |

### MEMO

- Normally move the height-adjustment lever to "LOW". For media that is wrinkled or comes loose from the platen during printing, move the height-adjustment lever to "MID" or "HIGH".
- The printing quality degrades as the distance between the media and the print heads increases. Do not move the height-adjustment lever to "MID" or "HIGH" needlessly.

6. Close the front cover.
7. Press [MENU] to go back to the original screen.

### MEMO

- Default setting: "LOW"
- If degradation of printing quality occurs after raising the print head height, refer to the following page and try optimizing the quality.

### RELATED LINKS

---

- P. 70 "Adjusting the Misalignment of the Ink Landing Position"
  - P. 72 "Accurately Adjusting the Misalignment of the Ink Landing Position"
  - P. 85 "Preventing Soiling of the Media, Dot Drop-out, and Dot Displacement"
-

## Using Transparent Media

You can even set up transparent media by setting "SHEET TYPE" to "CLEAR" and manually setting the media width and the loading position.

Normally, detecting the leading and trailing edges of the media enables you to verify the presence of the media, and the media is then ready for setup. However, since transparent media cannot be detected, setup will not be possible.

### 1. Set the media type to "CLEAR".

#### Procedure

1. Press [MENU].
2. Press [▼] several times to display the screen shown below.

```
MENU ◀◀
SUB MENU ▶
```

3. Press [▶] to display the screen shown below.

```
SUB MENU ◀◀
SHEET TYPE ▶
```

4. Press [▶] to display the screen shown below.

```
SHEET TYPE ◀◀
OPAQUE ▶ OPAQUE ↵
```

5. Press [▲] or [▼] to select "CLEAR".

```
SHEET TYPE ◀◀
OPAQUE ▶ CLEAR ↵
```

6. Press [ENTER] to confirm your entry.

#### MEMO

- Default setting: "OPAQUE"
- When set to "CLEAR", printing operation does not stop when the media runs out. If media runs out while printing is in progress, immediately press [PAUSE] to stop printing. Otherwise, there is a chance that the platen or other parts may become soiled by ink or that ink may get inside and damage the machine.

### 2. Set the media width.

#### Procedure

1. Press [◀], then [▼] to display the screen shown below.

```
SUB MENU ◀◀
SHEET WIDTH ▶
```

2. Press [▶] to display the screen shown below.

```
SHEET WIDTH ◀◀
1625mm ▶ 1625mm ↵
```

3. Press [▲] or [▼] to enter the width of the media.
4. Press [ENTER].
5. Press [MENU] to go back to the original screen.



**MEMO**

- Default setting: "1625 mm"
- When you select the "CLEAR" setting, printing is performed with media assumed to be at the set media width. Set "SHEET WIDTH" correctly according to the actual media width. Otherwise, there is a chance that the platen or other parts may become soiled by ink or that ink may get inside and damage the machine.

### 3. Load transparent media in the machine.

**Procedure**

**1. Load the media.**

➤ P. 28 "Setup of Media"

**2. Press [MENU].**

**3. Press [▼] several times to display the screen shown below.**

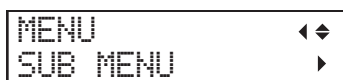

**4. Press [▶] once, and then press [▼] several times to display the screen shown below.**



**5. Press [▶].**

The print-head carriage moves to the currently set position, and then the screen shown below is displayed.



**6. Open the front cover.**

**7. Press [◀] or [▶] to move the print-head carriage's base point mark to the right edge of the media.**

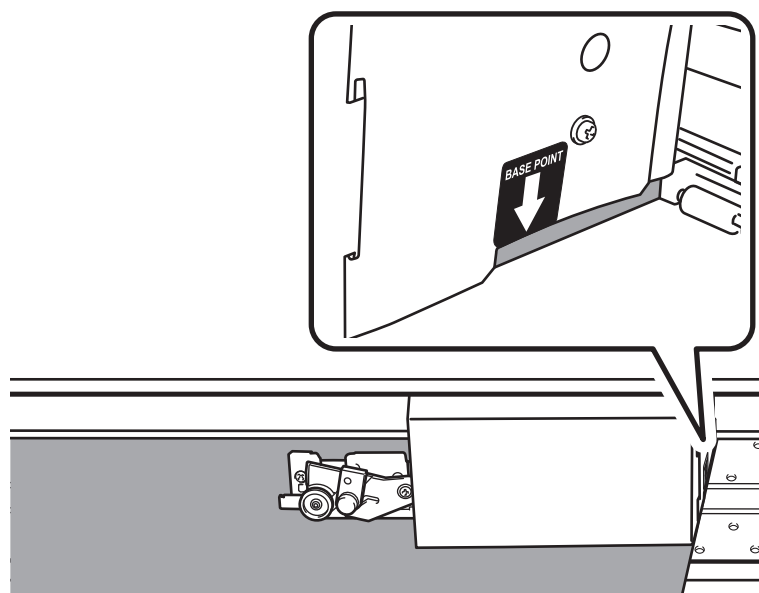

**IMPORTANT**

If a fixed period of time passes while the setting procedure is in progress, the menu is closed. The print heads are forcibly returned to the home position to prevent them from drying out. In this case, perform the procedure again from step 2.

**MEMO**

To quit the procedure for setting the position of the right edge of the media

- (1) Close the front cover.
- (2) Press [▼] to display the screen shown below.

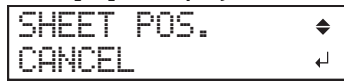

- (3) Press [ENTER].

The print-head carriage returns to the home position.

**8.** After positioning, close the front cover.

**9.** Press [ENTER] to confirm your entry.

This completes setup.

## Using Hard-to-Dry Media

This setting is used to extend the drying time when the ink dries poorly even if the dryer is used.

### Procedure

1. Press [MENU].
2. Press [▼] several times to display the screen shown below.

```
MENU ◀◆
SUB MENU ▶
```

3. Press [▶] once, and then press [▼] several times to display the screen shown below.

```
SUB MENU ◀◆
SCAN INTERVAL ▶
```

4. Press [▶] to display the screen shown below.

```
SCAN INTERVAL ◀◆
OFF ▶ OFF ↵
```

5. Press [▲] or [▼] to select a value.

Larger values cause the media to move more slowly, enabling you to extend the drying time accordingly.

6. Press [ENTER] to confirm your entry.
7. Press [MENU] to go back to the original screen.

### MEMO

- Default setting: "OFF"
- Depending on the software RIP you are using, you can also make this setting in the software RIP. When you have made the setting in the software RIP, the printer's setting is ignored.

## Using Media That Wrinkles Easily/Does Not Move Smoothly

The platen uses suction to grip the media and keep it stable. The suction force can be adjusted corresponding to the nature and condition of the media.

### Procedure

1. Press [MENU].
2. Press [▼] several times to display the screen shown below.

```
MENU ◀◆
SUB MENU ▶
```

3. Press [▶] once, and then press [▼] several times to display the screen shown below.

```
SUB MENU ◀◆
VACUUM POWER ▶
```

4. Press [▶] to display the screen shown below.

```
VACUUM POWER ◀◆
 AUTO ▶ AUTO ◀
```

5. Press [▲] or [▼] to select a value.

|           |                                                                                                                                |
|-----------|--------------------------------------------------------------------------------------------------------------------------------|
| 0 to 100% | When the media is flimsy and cannot move smoothly, decreasing this value (reducing the suction force) may correct the problem. |
| "AUTO"    | The suction force is automatically adjusted to the optimal level for the media width                                           |

6. Press [ENTER] to confirm your entry.
7. Press [MENU] to go back to the original screen.

#### MEMO

- Default setting: "AUTO"
- Depending on the software RIP you are using, you can also make this setting in the software RIP. When you have made the setting in the software RIP, the machine's setting is ignored.

## Using Sticky Media

This setting is used to peel off the media before starting printing when using media that sticks easily to the platen. This setting is effective to prevent media jams.

Note, however, that peeling off the media may cause unstable media feed. Leave this menu item set to "DISABLE" unless you specifically need to change it.

### Procedure

1. Press [MENU].
2. Press [▼] several times to display the screen shown below.

```
MENU ◀◆
SUB MENU ▶
```

3. Press [▶] once, and then press [▼] several times to display the screen shown below.

```
SUB MENU ◀◆
MEDIA RELEASE ▶
```

4. Press [▶] to display the screen shown below.

```
MEDIA RELEASE ◀◆
DISABLE▶DISABLE↵
```

5. Press [▲] or [▼] to select "ENABLE".
6. Press [ENTER] to confirm your entry.
7. Press [MENU] to go back to the original screen.

#### MEMO

Default setting: "DISABLE"

# Preventing Ink Discharge Issues

## Preventing Soiling of the Media, Dot Drop-out, and Dot Displacement

Printing by removing the ink buildup on the print head surface before or during printing prevents soiling of the media, dot drop-out, and dot displacement.

In the following cases, ink tends to collect on the surface of the print heads.

- When you use media prone to static electricity buildup.
- When the ambient temperature is low.
- When the print-head height is set to "HIGH".

### Procedure

1. Press [MENU].
2. Press [▼] several times to display the screen shown below.

```
MENU ◀◆
SUB MENU ▶
```

3. Press [▶] once, and then press [▼] several times to display the screen shown below.

```
SUB MENU ◀◆
PERIODIC CL. ▶
```

4. Press [▶] to display the screen shown below.  
The current setting is displayed on the screen.

```
PERIODIC CL. ◀◆
NONE ↵
```

5. Press [▲] or [▼] to select a setting.

|                  |                                                                                                                                                                                                                                                                                                                          |
|------------------|--------------------------------------------------------------------------------------------------------------------------------------------------------------------------------------------------------------------------------------------------------------------------------------------------------------------------|
| "NONE"           | Automatic cleaning is not performed.                                                                                                                                                                                                                                                                                     |
| "PAGE"           | Automatic cleaning is performed each time prior to the start of printing.                                                                                                                                                                                                                                                |
| "INTERVAL(JOB)"  | Automatic cleaning is performed when the cumulative printing time reaches the value you set here. However, if this time is reached during printing, automatic cleaning is performed before the next printing operation starts. Because printing is not paused, uneven color issues due to paused operation do not occur. |
| "INTERVAL(TIME)" | Automatic cleaning is performed when the cumulative printing time reaches the value you set here. When this time is reached during printing, printing pauses and so colors may be uneven.                                                                                                                                |

6. Press [ENTER] to confirm your entry.
7. Press [MENU] to go back to the original screen.

### MEMO

- Default setting: "NONE"
- Settings other than "NONE" result in longer printing times.

# Adjusting the Ink-drying Method

## What Is the Media Heating System?

This machine is equipped with a media heating system that warms the media. You use this mainly to improve ink adhesion and dry the ink. You can adjust the temperature settings to match the type of media and the printing speed.

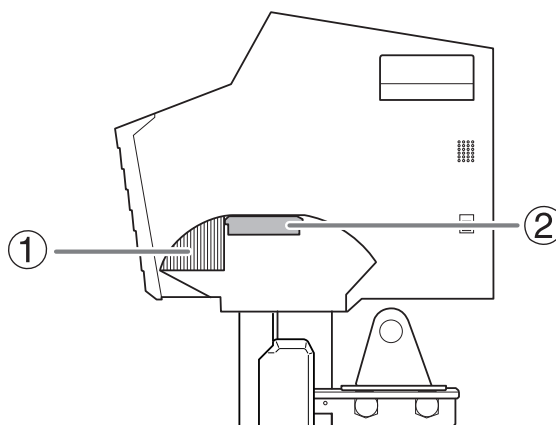

|   |              |                                                     |
|---|--------------|-----------------------------------------------------|
| ① | Dryer        | This is used to speed up the drying of the ink.     |
| ② | Print heater | This heater is used mainly to improve ink adhesion. |

- ⚠ WARNING**     **High temperatures**  
The platen and dryer become hot. Exercise caution to avoid burns.
- ⚠ WARNING**     **When output is not being performed, remove any loaded media or switch off the sub power.**  
The continued application of heat at a single location may cause the release of toxic gases from the media or pose a fire hazard.
- ⚠ WARNING**     **Never use media that cannot withstand heat.**  
Doing so may result in fire or the release of toxic gases or may degrade the media.
- ⚠ WARNING**     **Never use the platen or dryer for any purpose for which they are not intended, such as to dry clothing.**  
Doing so may cause overheating, resulting in fire or accident.

### IMPORTANT

Use the machine in an environment with an ambient temperature of 20 to 32°C (68 to 90°F).

If the machine is used at an ambient temperature lower than 20°C (68°F), then depending on the type or width of the media, wrinkling or temperature-caused unevenness may occur. If this happens, try lowering the temperature of the media heating system by about 2°C (3.6°F). To obtain stable printing results, however, use the machine in an environment with an ambient temperature of 20 to 32°C (68 to 90°F).

### MEMO

By using an auxiliary drying unit, you can speed up the drying of the ink more. For information about purchasing an auxiliary drying unit, contact your authorized Roland DG Corporation dealer or visit our website (<http://www.rolanddg.com/>).

### RELATED LINKS

- P. 94 "Using an Auxiliary Drying Unit"

## Setting the Print Heater Temperature

Setting the temperature of the print heater appropriately improves ink adhesion and inhibits smudging.

- With the default settings, simply switching on the power does not make the dryer warm up to the set temperature. The temperature rises to the set temperature when the media is loaded correctly and [SETUP] lights.
- Depending on the usage environment, the temperature of the print heater may become higher than the set temperature, but this does not represent a problem.
- Temperature settings are not possible when heater settings "POWER" is "OFF".

### Procedure

1. Press [FUNCTION].
2. Press [▼] several times to display the screen shown below.

```

FUNCTION ◀◆
HEATER CONFIG ▶

```

3. Press [▶] or [▼] to display the screen shown below.

```

HEATER CONFIG ◀◆
PRINT 40°C ▶

```

4. Press [▶] to display the screen shown below.

```

PRINT ◀◆
40°C ▶ 40°C ◀

```

5. Press [▲] or [▼] to select the temperature.

If the ink forms lumps or smudges, raise the temperature. Note, however, that a temperature that is too high may degrade the media or cause it to wrinkle.

You can also set the temperature to "OFF". When set to "OFF", the print heater does not operate at all.

6. Press [ENTER] to confirm your entry.
7. Press [FUNCTION] to go back to the original screen.

### MEMO

- Default setting: 40°C (104°F)
- You can also make this setting in the software RIP. When you have made the setting in the software RIP, the software RIP's setting is used.

### RELATED LINKS

- P. 93 "Switching Off the Print Heater and Dryer Together"



## Setting the Dryer Temperature

Setting the temperature of the dryer appropriately makes the ink dry fast.

- With the default settings, simply switching on the power does not make the dryer warm up to the set temperature. The temperature rises to the set temperature when the media is loaded correctly and [SETUP] lights.
- Depending on the usage environment, the temperature of the print heater may become higher than the set temperature, but this does not represent a problem.
- Temperature settings are not possible when heater settings "POWER" is "OFF".

### Procedure

1. Press [FUNCTION].
2. Press [▼] several times to display the screen shown below.

```
FUNCTION ◀◆
HEATER CONFIG ▶
```

3. Press [▶] once, and then press [▼] twice to display the screen shown below.

```
HEATER CONFIG ◀◆
DRYER 40°C ▶
```

4. Press [▶] to display the screen shown below.

```
DRYER ◀◆
50°C ▶ 50°C ◀
```

5. Press [▲] or [▼] to select the temperature.

When ink drying is poor, raise the temperature. Note, however, that a temperature that is too high may degrade the media or cause it to wrinkle.

You can also set the temperature to "OFF". When set to "OFF", the dryer does not operate at all.

6. Press [ENTER] to confirm your entry.
7. Press [FUNCTION] to go back to the original screen.

### MEMO

- Default setting: 45°C (113°F)
- You can also make this setting in the software RIP. When you have made the setting in the software RIP, the software RIP's setting is used.

---

## Hints and Tips for Temperature Control

The optimal temperature for the media heating system varies according to such factors as the type of media and the settings of the software RIP.

### **Relationship between the quality settings of the software RIP and temperature**

If smudging or poor drying occur even after raising the temperature, try setting the printing quality of the software RIP to higher image quality. Conversely, if you want to use a faster print quality, raise the temperature.

### **Amount of ink**

When you change the amount of ink using the settings for your software RIP, adjusting this may yield better results. If problems such as smudging persist even after raising the temperature, try reducing the amount of ink.

### **Other points to remember**

When recommended settings for temperature, printing quality, and other values are given for your media, use the suggested settings.

## Setting the Temperature during Preheating

Preheating: State in which the main power and the sub power are switched on and [SETUP] is not lit (state in which the media setup is not completed).

### Procedure

1. Press [MENU].
2. Press [▼] several times to display the screen shown below.

```
MENU ◀◆
HEATER MENU ▶
```

3. Press [▶], then [▼] to display the screen shown below.

```
HEATER MENU ◀◆
PREHEATING ▶
```

4. Press [▶] to display the screen shown below.

```
PREHEATING ◀◆
30°C ▶ 30°C ◀
```

5. Press [▲] or [▼] to select a setting.
  - MENU: The system performs heating to the set temperature at all times, without lowering the temperature during preheating.
  - 30°C: The system maintains a temperature of 30°C (86°F) during preheating.
  - OFF: The system switches the media heating system off during preheating.
6. Press [ENTER] to confirm your entry.
7. Press [MENU] to go back to the original screen.

### MEMO

Default setting: 30°C

## Drying the Trailing Edge of the Printing Area on the Dryer

To dry the ink thoroughly, configure the settings so that the media is fed until the trailing edge of the printed area is put on the dryer after the printing is finished.

### Procedure

1. Press [MENU].
2. Press [▼] several times to display the screen shown below.

```
MENU ◀◆
HEATER MENU ▶
```

3. Press [▶] twice to display the screen shown below.

```
FEED FOR DRY ◆
DISABLE▶DISABLE↓
```

4. Press [▲] or [▼] to select "ENABLE" or "DISABLE".

|           |                                                                                                                                                                                                                                                                                                                                                          |
|-----------|----------------------------------------------------------------------------------------------------------------------------------------------------------------------------------------------------------------------------------------------------------------------------------------------------------------------------------------------------------|
| "ENABLE"  | Media feed is performed until the trailing edge of the printing area is positioned on the dryer. The margin between the print-end position and the next print-start position is set to a value of 100 mm (3.9 in.) when "OPTION DRYER" is set to "DISABLE" and 280 mm (11.0 in.) when it is set to "ENABLE".<br>➤ P. 94 "Using an Auxiliary Drying Unit" |
| "DISABLE" | Media feed stops when printing ends. This means that the trailing edge of the printing area is not fed to the dryer unless you continue with a subsequent printing operation.                                                                                                                                                                            |

5. Press [ENTER] to confirm your entry.
6. Press [MENU] to go back to the original screen.

#### MEMO

Default setting: "DISABLE"

## Setting the Drying Time after Printing

To dry the ink thoroughly, set the drying time after the 1st page is printed.

### Procedure

1. Press [MENU].
2. Press [▼] several times to display the screen shown below.

```
MENU ◀◆
HEATER MENU ▶
```

3. Press [▶] once, and then press [▼] several times to display the screen shown below.

```
HEATER MENU ◀◆
DRYING TIME ▶
```

4. Press [▶] to display the screen shown below.

```
DRYING TIME ◀◆
 0min ▶ 0min←
```

5. Press [▲] or [▼] to select the drying time.
6. Press [ENTER] to confirm your entry.
7. Press [MENU] to go back to the original screen.

### MEMO

- Default setting: 0 min
- The next operation is not started until the set time elapses.
- During drying, [PAUSE] is lit. Press [PAUSE] while [PAUSE] is lit to finish the drying time and start the next operation.
- Hold down [PAUSE] while [PAUSE] is lit to cancel the output.
- When the drying time has been set in the software RIP, priority is given to the software RIP's setting.

## Switching Off the Print Heater and Dryer Together

This setting is useful when you want to switch off the media heating systems collectively. Setting "POWER" to "OFF" in the heater settings will make it impossible to set the temperature of the print heater and dryer.

### Procedure

1. Press [FUNCTION].
2. Press [▼] several times to display the screen shown below.

```

FUNCTION ◀◆
HEATER CONFIG ▶

```

3. Press [▶] to display the screen shown below.

```

HEATER CONFIG ◀◆
POWER ON ▶

```

4. Press [▶].
5. Press [▲] or [▼] to select "OFF."

```

HEATER CONFIG ◀◆
ON ▶ OFF ◀

```

6. Press [ENTER] to confirm your entry.  
The settings for the print heater and dryer are turned off.
7. Press [FUNCTION] to go back to the original screen.

#### MEMO

Default setting: "ON"

#### IMPORTANT

When this is set to "OFF", the heater will not turn on even if the heater temperature is set in the software RIP.

## Using an Auxiliary Drying Unit

This setting is required when using an auxiliary drying unit. By using an auxiliary drying unit, you can dry the ink faster.

### Procedure

1. Press [MENU].
2. Press [▼] several times to display the screen shown below.

```
MENU ◀◆
HEATER MENU ▶
```

3. Press [▶] once, and then press [▼] several times to display the screen shown below.

```
HEATER MENU ◀◆
OPTION DRYER ▶
```

4. Press [▶] to display the screen shown below.

```
OPTION DRYER ◀◆
DISABLE▶DISABLE↵
```

5. Press [▲] or [▼] to select "ENABLE".
6. Press [ENTER] to confirm your entry.
7. Press [MENU] to go back to the original screen.

### MEMO

- Default setting: "DISABLE"
- For recommended auxiliary drying unit models, contact your authorized Roland DG Corporation dealer or visit our website (<http://www.rolanddg.com/>).
- For details on how to use the auxiliary drying unit, refer to the documentation of the drying unit you are using.

## Using a Blower-fan Unit

This setting is required when using the optional blower-fan unit. By using a blower-fan unit, you can dry the ink faster.

### Procedure

1. Press [MENU].
2. Press [▼] several times to display the screen shown below.

```
MENU ◀◆
HEATER MENU ▶
```

3. Press [▶] once, and then press [▼] several times to display the screen shown below.

```
HEATER MENU ◀◆
BLOWER FAN ▶
```

4. Press [▶] to display the screen shown below.

```
BLOWER FAN ◀◆
DISABLE▶DISABLE↓
```

5. Press [▲] or [▼] to select "ENABLE".
6. Press [ENTER] to confirm your entry.
7. Press [MENU] to go back to the original screen.

### MEMO

- Default setting: "DISABLE"
- For recommended blower-fan unit models, contact your authorized Roland DG Corporation dealer or visit our website (<http://www.rolanddg.com/>).
- For details on how to use the blower-fan unit, refer to the documentation of the blower-fan unit you are using.



# Optimizing Work Efficiency

---

|                                                                                   |     |
|-----------------------------------------------------------------------------------|-----|
| Using Presets .....                                                               | 97  |
| Saving the Current Settings in Presets .....                                      | 97  |
| Loading and Outputting a Preset .....                                             | 99  |
| Adjusting the Output-start Location.....                                          | 100 |
| Setting the Base Point .....                                                      | 100 |
| Reducing Output Time .....                                                        | 102 |
| Speeding Up Output for Narrow Media.....                                          | 102 |
| Adjusting the Printing Area .....                                                 | 103 |
| Set the margins.....                                                              | 103 |
| Using the Media Take-up Unit.....                                                 | 104 |
| About the Media Take-Up Unit .....                                                | 104 |
| Performing Operations from the Dedicated Mobile Operation Application .....       | 105 |
| What Is the Dedicated Mobile Operation Application? .....                         | 105 |
| Downloading the Operation Application .....                                       | 106 |
| Using the Operation Application .....                                             | 107 |
| Important Notes on Using the Operation Application .....                          | 108 |
| Other Useful Functions .....                                                      | 110 |
| Using the Print Light (Interior Light) .....                                      | 110 |
| Performing Printing Tests Arranged Horizontally .....                             | 111 |
| Using Media Flanges for Paper Tubes (Cores) with an Internal Diameter of 2 Inches | 112 |

# Using Presets

## Saving the Current Settings in Presets

Using the "PRESET" menu lets you easily change a wide variety of settings to optimize them for the media.

Up to eight types of presets can be saved. You can assign a name to each one. Using media names for these may aid recognition and clarity. Making changes for each menu item every time you change the media can be troublesome. That's why it can be useful to save the menu-item settings optimized for an often-used type of media as a preset. The next time you use the media, you can change the menu-item settings to the optimal values for the media simply by loading the preset you saved.

### Procedure

1. Press [MENU].
2. Press [▼] to display the screen shown below.

```
MENU ◀◆
PRESET ▶
```

3. Press [▶] once, and then press [▼] twice to display the screen shown below.

```
PRESET ◀◆
SAVE ▶
```

4. Press [▶] to display the screen shown below.

```
SAVE ◀◆
NAME1 ↵
```

5. Decide on the preset number.

- (1) Press [▲] or [▼] to select one option from "NAME1" to "NAME8".
- (2) Press [ENTER] to confirm your entry.

The current menu settings are saved, and then the screen shown below appears.

```
SET NAME ◆▶
S ↵
```

6. Set the preset name.

- (1) Press [▲] or [▼] to select a character.
- (2) When you have selected the character you want to enter, press [▶].

The characters you can enter are "A" through "Z," "0" through "9," and the "-" character.

- (3) Press [▲] or [▼] to select the next character.

Select the following characters in the same way. You can enter up to 15 characters, including spaces.

```
SET NAME ◆◆▶
SAMPLE ↵
```

- (4) When you have finished, press [ENTER] to confirm your entry.

7. Press [MENU] to go back to the original screen.

The menu items that can be saved in presets are listed below.

| Menu item | Reference page                                 |
|-----------|------------------------------------------------|
| "HEATER"  | ▶ P. 87 "Setting the Print Heater Temperature" |
| "DRYER"   | ▶ P. 88 "Setting the Dryer Temperature"        |

| Menu item                           | Reference page                                                              |
|-------------------------------------|-----------------------------------------------------------------------------|
| "PREHEATING"                        | ➤ P. 90 "Setting the Temperature during Preheating"                         |
| "FEED FOR DRY"                      | ➤ P. 91 "Drying the Trailing Edge of the Printing Area on the Dryer"        |
| "DRYING TIME"                       | ➤ P. 92 "Setting the Drying Time after Printing"                            |
| "MEDIA GAP ADJ. SIMPLE SETTING"     | ➤ P. 70 "Adjusting the Misalignment of the Ink Landing Position"            |
| "MEDIA GAP ADJ. DETAIL SETTING"     | ➤ P. 72 "Accurately Adjusting the Misalignment of the Ink Landing Position" |
| "CALIBRATION"                       | ➤ P. 75 "Reducing Horizontal Bands (Feed Correction Function)"              |
| "SHEET TYPE""SHEET WIDTH""SHEETPOS" | ➤ P. 79 "Using Transparent Media"                                           |
| "SIDE MARGIN"                       | ➤ P. 103 "Set the margins."                                                 |
| "SCAN INTERVAL"                     | ➤ P. 82 "Using Hard-to-Dry Media"                                           |
| "VACUUM POWER"                      | ➤ P. 83 "Using Media That Wrinkles Easily/Does Not Move Smoothly"           |
| "FULL WIDTH S"                      | ➤ P. 102 "Speeding Up Output for Narrow Media"                              |
| "MEDIA RELEASE"                     | ➤ P. 84 "Using Sticky Media"                                                |

## Loading and Outputting a Preset

This loads a saved preset from among the eight types of presets. If you load a preset while [SETUP] is lit, [SETUP] flashes. After that, when the setup operation is complete, [SETUP] returns to being lit.

### Procedure

1. Press [MENU].
2. Press [▼] to display the screen shown below.

```
MENU ◀◆
PRESET ▶
```

3. Press [▶], then [▼][▶] to display the screen shown below.

```
LOAD ◀◆
NAME1 ↵
```

4. Select the preset that you want to load.
  - (1) Press [▲] or [▼] to select the name of the preset you want to load.
  - (2) Press [ENTER] to confirm your entry.
5. Press [MENU] to go back to the original screen.

# Adjusting the Output-start Location

## Setting the Base Point

Set the base point in order to determine the area on the loaded media in which to print (the output area).

The base point (Ⓑ) indicates the right edge of the output area (①). (②: Media feed direction, ③: print-head carriage movement direction) You can print without setting the base point, but setting the output area enables you to use media without being wasteful and also to print on the targeted location.

Make this setting for each individual page. When the printing of one page finishes, the base point returns to its default value.

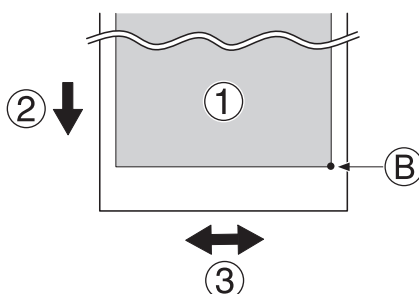

### MEMO

- Note that the left and right positions are not restored to their defaults for test patterns.
- If you are using the media take-up unit (sold separately), do not press [▲] after you finish setting up the media. Pressing [▲] will cause the machine to make an emergency stop in order to protect the motor.

### Procedure

1. Press [◀] while the following screen is displayed.  
The print-head carriage comes out over the platen.

W1100mm

2. Press [◀], [▶], [▲], or [▼] to move the print-head carriage to the position where you want to set the base point.

| Printing-start position in feed direction (forward-backward)                                                                             | Printing-start position in scan direction (left-right)                                                                                            |
|------------------------------------------------------------------------------------------------------------------------------------------|---------------------------------------------------------------------------------------------------------------------------------------------------|
| Move the media to adjust the feed direction. The center position of the reflective tape (Ⓔ) is the start position in the feed direction. | Move the print-head carriage to adjust the scan direction. The base point mark on the right side is the start position in the scan direction (Ⓕ). |
|                                                                                                                                          |                                                                                                                                                   |

3. Once the position has been decided, press [FUNCTION] to display the screen shown below.

FUNCTION     ◀▶  
BASE POINT     ↵

**4.** Press [ENTER] to confirm your entry.

When the screen displays the character "B" together with the printable width at the location (as shown in the following figure), setting is completed.



# Reducing Output Time

## Speeding Up Output for Narrow Media

This shortens output time by reducing the width of head movement to the minimum necessary. This is effective when the width of the media or the output data is narrow.

### Procedure

1. Press [MENU].
2. Press [▼] several times to display the screen shown below.

```
MENU ◀◆
SUB MENU ▶
```

3. Press [▶] once, and then press [▼] several times to display the screen shown below.

```
SUB MENU ◀◆
FULL WIDTH S ▶
```

4. Press [▶] to display the screen shown below.

```
FULL WIDTH S ◀◆
FULL ▶ FULL ↵
```

5. Press [▲] or [▼] to select "SHEET" or "OFF".

```
FULL WIDTH S ◀◆
FULL ▶ OFF ↵
```

|         |                                                                                                                                                                                                                                                                                    |
|---------|------------------------------------------------------------------------------------------------------------------------------------------------------------------------------------------------------------------------------------------------------------------------------------|
| "SHEET" | "SHEET" matches the range of print head movement to the width of the media.                                                                                                                                                                                                        |
| "OFF"   | "OFF" matches the range of print head movement to the output data. Movement is limited to the minimum amount necessary, and this can be expected to yield the fastest output. Note, however, that because the speed of media movement is no longer constant, colors may be uneven. |
| "FULL"  | "FULL" makes the speed of media movement constant at all times and produces the most stable printing result.                                                                                                                                                                       |

6. Press [ENTER] to confirm your entry.
7. Press [MENU] to go back to the original screen.

#### MEMO

Default setting: "FULL"

# Adjusting the Printing Area

## Set the margins.

This sets the distance from the left or right media clamp to the corresponding left or right edge of the printing area.

### Procedure

1. Press [MENU].
2. Press [▼] several times to display the screen shown below.

```
MENU ◀◆
SUB MENU ▶
```

3. Press [▶] once, and then press [▼] several times to display the screen shown below.

```
SUB MENU ◀◆
SIDE MARGIN ▶
```

4. Press [▶] to display the screen shown below.

```
SIDE MARGIN ◀◆
10mm ▶ 10mm ◀
```

5. Press [▲] or [▼] to select the margin from those shown below.
  - "5 mm"
  - "10 mm"
  - "25 mm"
6. Press [ENTER] to confirm your entry.
  - If the media has already been set, the message "PRESS ENTER KEY TO SET UP" is displayed on the screen.
  - If the media has not yet been set, press [MENU] to go back to the original screen.

### MEMO

Default setting: "10 mm"

### RELATED LINKS

- P. 28 "Setup of Media"
- P. 210 "Maximum Printing Area and Margins"



# Using the Media Take-up Unit

---

## About the Media Take-Up Unit

- The media take-up unit (hereinafter referred to as the "take-up unit") is an optional item.
- For information on how to assemble, install, and operate the take-up unit, refer to the take-up unit user's manual.
- For recommended take-up unit models, contact your authorized Roland DG Corporation dealer or visit our website (<http://www.rolanddg.com/>).

# Performing Operations from the Dedicated Mobile Operation Application

---

## What Is the Dedicated Mobile Operation Application?

The dedicated mobile operation application (hereinafter referred to as the "operation application") is an application for mobile terminals. This application can be used to operate the machine by way of Bluetooth communication.

### Required System Environment

|                             |                                                                                                                                                                                                                         |
|-----------------------------|-------------------------------------------------------------------------------------------------------------------------------------------------------------------------------------------------------------------------|
| Supported operating systems | <ul style="list-style-type: none"><li>• iOS 10.0 or later</li><li>• Android 6 or later (The operation application may not work on some Android devices even if their operating system is version 6 or later.)</li></ul> |
| Supported languages         | Japanese, English, French, German, Italian, Peninsular Spanish, Latin American Spanish                                                                                                                                  |
| Communication method        | Bluetooth 4.0 LE<br>The mobile terminal you are using must support the above communication method.                                                                                                                      |

For the latest information, visit the Roland DG Corporation website (<http://www.rolanddg.com/>).

### RELATED LINKS

---

- P. 107 "Using the Operation Application"
-

## Downloading the Operation Application

Visit the following URL or scan the QR code to download the app.

- Android:<https://play.google.com/store/apps/details?id=rolanddg.co.jp.mobilepanel>



- iOS:<https://itunes.apple.com/jp/app/roland-dg-mobile-panel-2/id1453358233>



---

## Using the Operation Application

### Procedure

1. Check that this machine is turned on.
2. Turn on Bluetooth communication on the machine.
  - P. 121 "Turning on Bluetooth Communication"
3. Turn on Bluetooth communication on the mobile terminal you are using.

For information on how to configure the settings, refer to the documentation for the mobile terminal you are using.
4. Start the operation application.

Use the operation application according to the instructions shown on your mobile terminal.

## Important Notes on Using the Operation Application

### Number of printers that you can connect to

You can only connect to one printer from a mobile terminal on which the operation application has been installed. You can register multiple printers, but you cannot connect to multiple printers at the same time.

### No pairing is required

Generally speaking, "pairing" is required to establish a Bluetooth connection. With the operation application, no "pairing" is required. After starting the operation application, follow the instructions on the screen to connect to the printer.

### Perform operations from a position where you can see the printer.

To enable immediate handling of unexpected printer operations, perform operation application operations from a position where you can see the printer.

### Important notes on Bluetooth communication

- With Bluetooth wireless technology, it is possible to establish a connection between devices separated by approximately 10 m (32.8 ft.). However, the valid range of the connection may vary depending on the presence of obstacles (such as people, metal, and walls) and the status of the radio waves.
- The communication status of the Bluetooth connection may become unstable if:
  - A wireless LAN is in place in the location.
  - The devices are in the vicinity of a microwave that is in use.
  - Other electromagnetic waves are generated in the location.
- Bluetooth communication uses the same frequency band (2.4 GHz) as wireless LAN (IEEE802.11b/g). If the devices are used in the vicinity of equipment in which a wireless LAN unit is installed, the connection status may become unstable due to the occurrence of radio-frequency interference. In this situation, carry out the following countermeasures.
  - When using Bluetooth communication to connect the printer and the mobile terminal, do so at a distance of 10 m (32.8 ft.) or more away from the equipment in which a wireless LAN unit is installed.
  - Bring the mobile terminal and the printer as close together as possible.
  - If using Bluetooth communication within 10 m (32.8 ft.) of the equipment in which a wireless LAN unit is installed, turn off the wireless LAN unit.
- The radio waves generated by Bluetooth communication may have an effect on the operation of electronic medical equipment and similar devices. This may lead to accidents, so turn off Bluetooth communication in the following locations.
  - The vicinity of in-use hearing aids and pacemakers
  - Hospitals
  - The vicinity of automatic doors and fire alarms
    - ▶ P. 121 "Turning on Bluetooth Communication"
- Using Bluetooth communication in the vicinity of TVs or radios may lead to noise in the image or audio.
- Roland DG Corporation accepts no responsibility for the leakage of information during a connection using Bluetooth technology.
- The mobile terminal that you are using to connect to the printer must comply with Bluetooth standards determined by the Bluetooth SIG and must be a certified device.
- Even if the mobile terminal complies with the Bluetooth standards outlined above, phenomena may occur due to the characteristics and specifications of the device. Examples of these

phenomena include the inability to connect to the printer and the operation methods, display, and operations being different.

- Depending on the mobile terminal that you are connecting to the printer, it may take some time until the Bluetooth connection can be established.
- While the Bluetooth connection is established, do not cover the mobile terminal with your hand or anything else. Doing so may hinder the Bluetooth connection.

### Other important notes

- Bluetooth communication may increase the mobile terminal's battery consumption.
- Additional communication charges apply to the downloading of the application. You will have to bear the communication charges.
- Note that it may take time to confirm whether this application is supported by new mobile terminals.
- Depending on the usage environment, this application may not operate normally even with mobile terminals that have been confirmed to be supported.

# Other Useful Functions

## Using the Print Light (Interior Light)

You can select the status of the light that shines on the platen.

### Procedure

1. Press [FUNCTION].
2. Press [▲] to display the screen shown below.

```
FUNCTION ◀◆
PRINT LIGHT ▶
```

3. Press [▶] to display the screen shown below.

```
PRINT LIGHT ◀◆
AUTO ▶ AUTO ◀
```

4. Press [▲] or [▼] to select the status of the print light.

```
PRINT LIGHT ◀◆
AUTO ▶ ON ◀
```

|        |                                                                                  |
|--------|----------------------------------------------------------------------------------|
| "AUTO" | The light is turned on/off automatically according to the status of the printer. |
| "ON"   | The light is on at all times.                                                    |
| "OFF"  | The light is off at all times.                                                   |

5. Press [ENTER] to confirm your entry.
6. Press [FUNCTION] to go back to the original screen.

### MEMO

Default setting: "AUTO"

## Performing Printing Tests Arranged Horizontally

When performing printing tests successively, you can select "FEED" (vertical printing) or "SCAN" (horizontal printing) as the print position for the second and later tests in comparison to the first test.

If you are using the optional media take-up unit, printing tests will be printed with the "FEED" orientation regardless of this setting.

### Procedure

1. Press [MENU].
2. Press [▼] several times to display the screen shown below.

```
MENU ◀◆
SUB MENU ▶
```

3. Press [▶], then [▲] to display the screen shown below.

```
SUB MENU ◀◆
TEST PRINT POS ▶
```

4. Press [▶] to display the screen shown below.

```
TEST PRINT POS ◀◆
FEED ▶ FEED ◀
```

5. Press [▲] or [▼] to select "SCAN".

```
TEST PRINT POS ◀◆
FEED ▶ SCAN ◀
```

6. Press [ENTER] to confirm your entry.
7. Press [MENU] to go back to the original screen.

#### MEMO

Default setting: "FEED"



## Using Media Flanges for Paper Tubes (Cores) with an Internal Diameter of 2 Inches

The media flanges for paper tubes (cores) with an internal diameter of 2 inches are optional items. For information about purchasing them, contact your authorized Roland DG Corporation dealer or visit our website (<http://www.rolanddg.com/>).

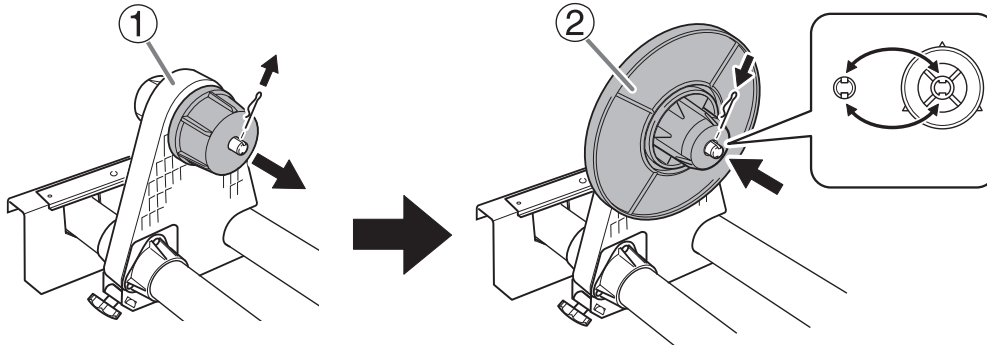

- ①: End cap: Remove the pin. If it is difficult to remove the pin, use a pair of pliers or a similar tool.
- ②: Media flange for 2-inch media: Align the depression with the projection, attach the media flange, and then insert the pin.

# Optimizing Operation Management

---

|                                                                                                  |     |
|--------------------------------------------------------------------------------------------------|-----|
| Managing the Operations Appropriately and Efficiently .....                                      | 114 |
| Setting the Current Date/Time and Using It for Maintenance.....                                  | 114 |
| Displaying the Amount of Media Remaining.....                                                    | 115 |
| Making Sure to Verify the Setting for the Amount Remaining Every Time the Media Is Changed ..... | 116 |
| Printing the Amount of Remaining Media.....                                                      | 117 |
| Setting the Activation Interval for Sleep Mode (Power-saving Feature) .....                      | 118 |
| Thoroughly Mixing the Ink Periodically .....                                                     | 119 |
| Managing the Basic Settings of the Printer .....                                                 | 120 |
| Setting the Menu Language and Units of Measurement .....                                         | 120 |
| Turning on Bluetooth Communication.....                                                          | 121 |
| Viewing System Information .....                                                                 | 123 |
| Returning All Settings to Factory Defaults .....                                                 | 124 |

# Managing the Operations Appropriately and Efficiently

## Setting the Current Date/Time and Using It for Maintenance

Set the current date/time. By setting this, when you perform a printing test the printing test date and time will be printed alongside the printed test pattern. When the message "TIME FOR MAINTENANCE" is displayed, the date/time of the previous manual cleaning will be displayed. When this message is displayed, perform manual cleaning.

### Procedure

1. Press [MENU].
2. Press [▼] several times to display the screen shown below.

```
MENU ◀◆
SUB MENU ▶
```

3. Press [▶] once, and then press [▼] several times to display the screen shown below.

```
SUB MENU ◀◆
CLOCK ▶
```

4. Press [▶] to display the screen shown below.

```
CLOCK ◀◆
DATE 2016/01/01▶
```

- (1) Press [▶].
  - (2) Press [▲] or [▼] to set the year.
  - (3) Press [▶].
  - (4) Press [▲] or [▼] to set the month.
  - (5) Press [▶].
  - (6) Press [▲] or [▼] to set the day.
5. Press [ENTER] to confirm your entry.
  6. Press [▼] to display the screen shown below.

```
CLOCK ◀◆
TIME 01:01:59▶
```

- (1) Press [▶].
  - (2) Press [▲] or [▼] to set the hour.
  - (3) Press [▶].
  - (4) Press [▲] or [▼] to set the minute.
  - (5) Press [▶].
  - (6) Press [▲] or [▼] to set the second.
7. Press [ENTER] to confirm your entry.
  8. Press [MENU] to go back to the original screen.

## Displaying the Amount of Media Remaining

You can display how much of the media in use is left. By setting the amount of media currently remaining at the start, the amount remaining will be constantly displayed on the screen until it reaches zero.

If you remove the media or cancel media loading by raising the loading lever, the amount remaining at that time flashes on the screen. Because the amount of media remaining is not updated automatically when you change the media, redo the setting whenever you change the media. You can also set the machine to display this menu automatically whenever you change the media.

### MEMO

The remaining amount that is displayed is only an estimate. Accuracy is not assured.

### Procedure

1. Press [MENU].
2. Press [▼] several times to display the screen shown below.



MENU ◀◆  
SHEET REMAIN ▶

3. Press [▶], then [▼] to display the screen shown below.



SHEET REMAIN ◀◆  
SET LENGTH ▶

4. Press [▶] to display the screen shown below.



SET LENGTH ◀◆  
0.0m ▶ 99.9m ◀

5. Press [▲] or [▼] to set the current amount of media remaining.



SET LENGTH ◀◆  
0.0m ▶ 25.0m ◀

6. Press [ENTER] to confirm your entry.
7. Press [MENU] to go back to the original screen.

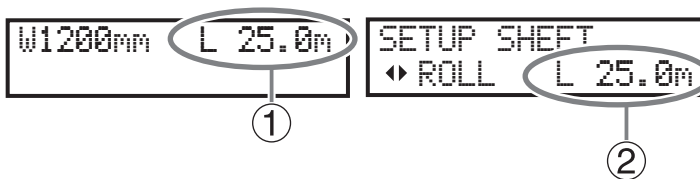

W1200mm L 25.0m

SETUP SHEET  
◀ ROLL L 25.0m

- ①: This display is updated.
- ②: If media has not been loaded, the set value flashes.

### RELATED LINKS

- P. 116 "Making Sure to Verify the Setting for the Amount Remaining Every Time the Media Is Changed"

## Making Sure to Verify the Setting for the Amount Remaining Every Time the Media Is Changed

Set the machine to display the amount of media remaining every time the media is changed.

Setting this menu item to "ENABLE" can keep you from forgetting to redo the setting when you change the media. However, be sure to also set the "SHEET TYPE" menu item to "OPAQUE". When "SHEET TYPE" is set to "CLEAR", "SET LENGTH" is not displayed automatically.

### Procedure

1. Press [MENU].
2. Press [▼] several times to display the screen shown below.

```
MENU ◀◆
SHEET REMAIN ▶
```

3. Press [▶], then [▲] to display the screen shown below.

```
SHEET REMAIN ◀◆
AUTO DISPLAY ▶
```

4. Press [▶] to display the screen shown below.

```
AUTO DISPLAY ◀◆
DISABLE▶DISABLE↵
```

5. Press [▲] or [▼] to select "ENABLE".

```
AUTO DISPLAY ◀◆
DISABLE▶ENABLE↵
```

6. Press [ENTER] to confirm your entry.

If you select "ENABLE", you must set the "SHEET TYPE" menu item to "OPAQUE".

7. Press [MENU] to go back to the original screen.

### MEMO

Default setting: "DISABLE"

### RELATED LINKS

- P. 79 "Using Transparent Media"

## Printing the Amount of Remaining Media

This prints the amount of media remaining, which is displayed on the top menu.

Use this when you want to make a record of the remaining length of the media currently in use. Printing the amount of media remaining before you change the media enables you to refer to the printed record and use the value to make the setting for the remaining amount the next time you use the media.

Note, however, that if you continue printing, the next printing operation will start on top of the portion where the amount of remaining media is printed. If you want to continue printing, separate the media before starting the next printing operation.

### Procedure

1. Press [MENU].
2. Press [▼] several times to display the screen shown below.

```
MENU ◀◆
SHEET REMAIN ▶
```

3. Press [▶] to display the screen shown below.

```
SHEET REMAIN ◀◆
PRINT MEMO ↵
```

4. Press [ENTER].  
Printing starts.
5. Press [MENU] to go back to the original screen.

## Setting the Activation Interval for Sleep Mode (Power-saving Feature)

This setting is used to set how long it should take until the machine goes into sleep mode (the state in which the power-saving feature is working) when no output data is received and no operations are performed for a continued length of time.

### Procedure

1. Press [MENU].
2. Press [▼] several times to display the screen shown below.

```
MENU ◀◆
SUB MENU ▶
```

3. Press [▶] once, and then press [▼] several times to display the screen shown below.

```
SUB MENU ◀◆
SLEEP ▶
```

4. Press [▶] twice to display the screen shown below.

```
INTERVAL ◀◆
30min ▶ 30min ◀
```

5. Press [▲] or [▼] to set the time.

```
INTERVAL ◀◆
30min ▶ 15min ◀
```

6. Press [ENTER] to confirm your entry.
7. Press [MENU] to go back to the original screen.

#### MEMO

Default setting: "30min"

## Thoroughly Mixing the Ink Periodically

To prevent ink precipitation, enable the function that notifies you to mix the ink.

When this is set to "ENABLE", the message "SHAKE ALL INK POUCH TRAY" appears once per week. This message appears when the sub power is turned on and when the machine returns from the sleep state.

Press [ENTER] to clear the message. When the message appears, remove all the pouch trays and mix their ink.

### Procedure

1. Press [MENU].
2. Press [▼] several times to display the screen shown below.

```
MENU ◀◆
SUB MENU ▶
```

3. Press [▶] once, and then press [▼] several times to display the screen shown below.

```
SUB MENU ◀◆
SHAKE ALERT ▶
```

4. Press [▶].
5. Press [▲] or [▼] to select "ENABLE".

```
SHAKE ALERT ◀◆
DISABLE▶ENABLE ↵
```

6. Press [ENTER] to confirm your entry.
7. Press [MENU] to go back to the original screen.

#### MEMO

- Default setting: "DISABLE"



# Managing the Basic Settings of the Printer

## Setting the Menu Language and Units of Measurement

This feature sets the language and units of measurement displayed on the display screen of the operation panel.

### Procedure

1. Hold down [MENU] and switch on the sub power.
2. Press [▲] or [▼] to select the display (menu) language.



MENU LANGUAGE  
ENGLISH

3. Press [ENTER] to confirm your entry.
4. Press [▲] or [▼] to select the measurement unit for length.



LENGTH UNIT  
mm ▶ INCH

5. Press [ENTER] to confirm your entry.
6. Press [▲] or [▼] to select the measurement unit for temperature.



TEMP. UNIT  
°C ▶ °F

7. Press [ENTER] to confirm your entry.

### MEMO

Default settings

- "MENU LANGUAGE": ENGLISH
- "LENGTH UNIT": mm
- "TEMP. UNIT": °C

## Turning on Bluetooth Communication

This machine supports the operation application, which is an application for mobile terminals. When using the operation application, set this machine's Bluetooth communication to "ENABLE". However, when you are operating this machine from its operation panel, you cannot perform operations from the operation application.

### Procedure

1. Press [MENU].
2. Press [▼] several times to display the screen shown below.

```
MENU ◀◆
SYSTEM INFO. ▶
```

3. Press [▶] once, and then press [▼] several times to display the screen shown below.

```
SYSTEM INFO. ◀◆
BLUETOOTH ▶
```

4. Press [▶] twice to display the screen shown below.

```
BLUETOOTH ◀◆
DISABLE▶DISABLE◀
```

5. Press [▲] or [▼] to select "ENABLE".

```
BLUETOOTH ◀◆
DISABLE▶ENABLE◀
```

6. Press [ENTER] to confirm your entry.

7. Press [◀] to display the screen shown below.

The current state is displayed on the screen.

```
BLUETOOTH ◀
ENABLE ▶
```

|           |                                                                                                                                                                                                                                                                                                                   |
|-----------|-------------------------------------------------------------------------------------------------------------------------------------------------------------------------------------------------------------------------------------------------------------------------------------------------------------------|
| "ENABLE"  | Bluetooth communication is on, and the printer is waiting for a connection to be established. If you cannot operate this machine from the dedicated mobile operation application (hereinafter referred to as the "operation application") that you are using, there is a problem with the connection environment. |
| "ENABLE"* | Bluetooth communication is on, and the printer is connected to the operation application.<br>However, when this screen is displayed, you cannot perform operations from the operation application.                                                                                                                |
| "DISABLE" | Bluetooth communication is off.                                                                                                                                                                                                                                                                                   |
| "ERROR"   | An error has occurred in Bluetooth communication. Purchase them from your authorized Roland DG Corporation dealer.                                                                                                                                                                                                |

8. Press [MENU] to go back to the original screen.

### MEMO

- Default setting: "DISABLE"
- There are some precautions regarding Bluetooth communication.
- For details on the operation application, visit the Roland DG Corporation website (<http://www.rolanddg.com/>).

### RELATED LINKS

- P. 192 "Printer Cannot Be Operated from the Operation Application"
- P. 105 "Performing Operations from the Dedicated Mobile Operation Application"

- P. 108 "Important Notes on Using the Operation Application"
-

## Viewing System Information

This is a method for viewing system information of this machine, such as serial number and ink type.

### Procedure

1. Press [MENU].
2. Press [▼] several times to display the screen shown below.



You can check the following information:

- "MODEL": Model name
- "SERIAL NO.": Serial number
- "INK": Ink type
- "FIRMWARE": Firmware version
- "NETWORK": Network settings such as the IP address
- "Bluetooth": Bluetooth communication state

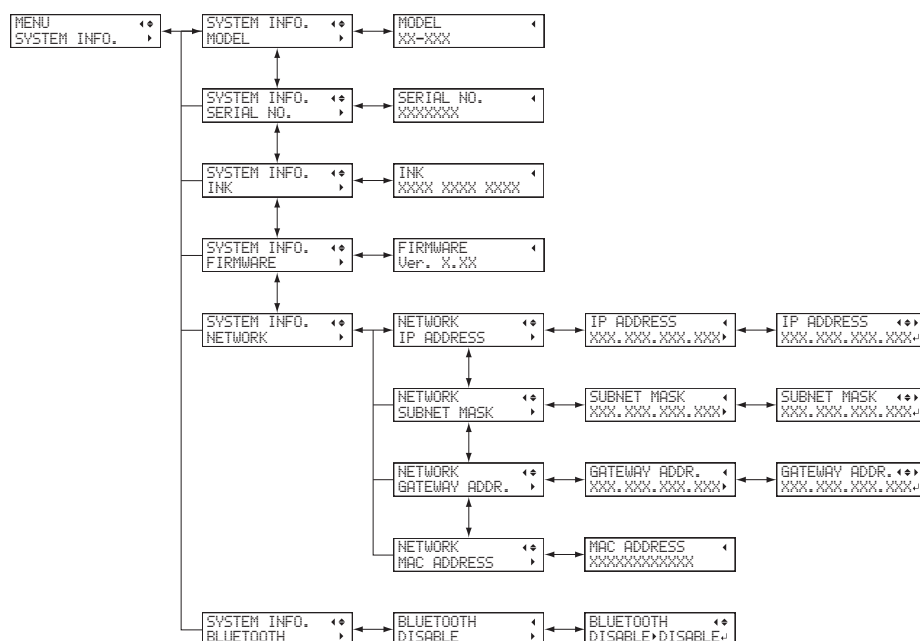

### MEMO

- For information on how to set up a network, see the "Setup Guide."
- Refer to the following page for information on how to set up Bluetooth communication.

### RELATED LINKS

- P. 121 "Turning on Bluetooth Communication"
- VF2-640 Setup Guide

## Returning All Settings to Factory Defaults

This menu returns all settings to the same as their factory defaults.

The settings for "MENU LANGUAGE", "LENGTH UNIT", and "TEMP. UNIT" are not returned to their factory default values.

### Procedure

1. Press [MENU].
2. Press [▼] several times to display the screen shown below.

```
MENU ◀◆
SUB MENU ▶
```

3. Press [▶] once, and then press [▼] several times to display the screen shown below.

```
SUB MENU ◀◆
FACTORY DEFAULT ↵
```

4. Press [ENTER] to execute the operation.

# Maintenance

# Introduction

---

|                                                                      |     |
|----------------------------------------------------------------------|-----|
| Important Notes on Handling and Use .....                            | 127 |
| Printer .....                                                        | 127 |
| Ink Pouches.....                                                     | 128 |
| Basic Maintenance Knowledge .....                                    | 129 |
| Types and Timing of Maintenance .....                                | 129 |
| Measures When the Printer Is Not in Use for a Prolonged Period ..... | 130 |

# Important Notes on Handling and Use

## Printer

- This machine is a precision device.
  - Never subject the machine to impacts or excessive force.
  - Never needlessly put your hand or fingers inside the cover, the ink-pouch ports, or other internal areas of the machine.
  - There is an area for small article storage on the front of the machine. Do not place in this area any items to which cleaning liquid or ink has affixed. Doing so may damage the area for small article storage.
- Install in a suitable location.
  - Install the machine in a location having the specified temperature and humidity.
  - Install the machine in a quiet, stable location offering good operating conditions.
- The print heads are delicate.
  - Never needlessly touch or allow media to scrape them.
  - The print heads may be damaged if allowed to dry out. The machine prevents desiccation automatically, but improper operation may render this feature inoperative. Operate the machine properly, as specified in this manual.
  - Never leave the machine with an ink pouch removed. Remaining ink in the printer may harden and clog the print heads.
  - The print heads require various types of cleaning depending on the situation. Read this manual thoroughly and perform the appropriate maintenance at the appropriate times.
  - The print heads are components that wear out. Periodic replacement is required, with the frequency of replacement depending on use.
- This machine becomes hot.
  - Never cover the ventilation holes with cloth, tape, or anything else.



## Ink Pouches

- Ink pouches come in various types.
  - Use a type that is compatible with the printer.
- Never subject to impact or attempt to disassemble.
  - Never drop the ink cartridges or shake them forcefully. The impact may rupture the internal pouch and cause the ink to leak.
  - Never attempt to disassemble the ink pouches.
  - Never attempt to refill the ink.
  - If ink gets on your hands or clothing, wash it off as soon as possible. Removal may become difficult if you leave such adhered ink untreated.
- Storage
  - Store ink pouches unopened in a well-ventilated location at a temperature of -5 to 40°C (-23 to 104°F). However, do not store the ink pouches for a prolonged period of time in low- or high-temperature environments.

# Basic Maintenance Knowledge

## Types and Timing of Maintenance

To use this machine under its optimal conditions, it is important to perform the appropriate maintenance at the appropriate times.

### Regular Maintenance

These are the maintenance items that are required on a daily basis.

| Timing                                         | Category                      | Item                                                        |
|------------------------------------------------|-------------------------------|-------------------------------------------------------------|
| After daily operations                         | Cleaning the machine          | ➤ P. 132 "Cleaning the Media Path"                          |
|                                                |                               | ➤ P. 133 "Cleaning the Knife Carriage Roller"               |
| When the discharged fluid is ready to overflow | Disposing of discharged fluid | ➤ P. 135 "If the Discharged Fluid Disposal Message Appears" |
|                                                |                               | ➤ P. 136 "If the Drain Bottle Exceeds Its Capacity Limit"   |
| When dot drop-out or dot displacement occurs   | Cleaning of the print heads   | ➤ P. 137 "Printing Tests and Normal Cleaning"               |
|                                                |                               | ➤ P. 140 "Medium Cleaning Method"                           |
|                                                |                               | ➤ P. 142 "Powerful Cleaning Method"                         |
|                                                |                               | ➤ P. 144 "Manual Cleaning"                                  |
| If colors are uneven                           | Eliminating uneven colors     | ➤ P. 152 "Mixing the Ink by Shaking the Pouch Tray"         |

### Advanced Maintenance

These maintenance methods consume a large amount of ink. Thoroughly read the explanation, and then perform the operation at the appropriate point in time.

| Timing                                | Category                                                      | Item                                                                                   |
|---------------------------------------|---------------------------------------------------------------|----------------------------------------------------------------------------------------|
| When uneven colors are not resolved   | Eliminating uneven colors, dot drop-out, and dot displacement | ➤ P. 154 "Damper Cleaning Method"<br>(When the ink type is CMYKLkOrGrW or CMYKLcLmLkW) |
| When manual cleaning is not effective |                                                               | ➤ P. 157 "Super Cleaning Method"                                                       |
| When damper cleaning is not effective |                                                               |                                                                                        |

### Replacing consumable parts

These items are for replacement of consumable parts. Thoroughly read the explanation, and then perform the operation at the appropriate point in time.

| Timing                             | Category                   | Item                                            |
|------------------------------------|----------------------------|-------------------------------------------------|
| When a replacement message appears | Replacing consumable parts | ➤ P. 166 "Replacing the Wiper and the Tray Pad" |
|                                    |                            | ➤ P. 169 "Cleaning the Wiper Tray"              |
| When a cutting edge becomes dull   | • Separating knife         | ➤ P. 171 "Replacing the Separating Knife"       |

---

## Measures When the Printer Is Not in Use for a Prolonged Period

Be sure to follow the instructions shown below when the printer is not in use for a prolonged period.

- **Empty the drain bottle.**

If you know that you will not use the machine for a prolonged period, empty the drain bottle. When the main power is on, the machine periodically performs automatic maintenance in which fluid is discharged.

The drain bottle is filled when the following periods elapse. Leaving the drain bottle as-is will lead to the discharged fluid overflowing.

- Approximately 2 weeks after the message "EMPTY DRAIN BOTTLE" is displayed

- P. 135 "If the Discharged Fluid Disposal Message Appears"

- Approximately 150 days after the drain bottle is emptied

- P. 136 "If the Drain Bottle Exceeds Its Capacity Limit"

- **Do not allow the machine to run out of ink or cleaning liquid.**

The machine discharges ink and cleaning liquid during the automatic maintenance that is performed periodically. Set in the machine ink and cleaning liquid pouches having sufficient remaining ink and cleaning liquid. The machine cannot perform automatic maintenance if it has run out of ink or cleaning liquid.

- **Switch on the sub power once a month.**

Switch on the sub power once a month. When you turn on the power, the machine automatically performs operations such as those to keep the print heads from drying out. Leaving the machine unused for a prolonged period may damage the print heads, so be sure to switch on the power to perform these automatic operations.

- **Keep the machine at a constant temperature and relative humidity.**

Even when the machine is not in use, keep it at a temperature of 5 to 40°C (41 to 104°F) and a relative humidity of 20 to 80% (with no condensation). Temperatures that are too high may degrade the ink and cause malfunctions. Temperatures that are too low may cause the ink to freeze and damage the print heads.

---

### RELATED LINKS

- P. 48 "Ink Pouch Replacement"
  - P. 50 "TR2 Cleaning Liquid Pouch Replacement"
-

# Regular Maintenance

---

|                                                               |     |
|---------------------------------------------------------------|-----|
| Cleaning the Machine .....                                    | 132 |
| Cleaning the Media Path .....                                 | 132 |
| Cleaning the Knife Carriage Roller .....                      | 133 |
| Disposing of Discharged Fluid.....                            | 134 |
| Precautions for Disposing of Discharged Fluid .....           | 134 |
| If the Discharged Fluid Disposal Message Appears .....        | 135 |
| If the Drain Bottle Exceeds Its Capacity Limit.....           | 136 |
| Daily Print Head Check .....                                  | 137 |
| Printing Tests and Normal Cleaning .....                      | 137 |
| When Normal Cleaning Is Not Effective .....                   | 140 |
| Medium Cleaning Method .....                                  | 140 |
| Powerful Cleaning Method .....                                | 142 |
| Manual Cleaning .....                                         | 144 |
| When Manual Cleaning Is Necessary.....                        | 144 |
| Manual Cleaning Method .....                                  | 145 |
| Consumable Products and Parts Related to Manual Cleaning..... | 151 |
| If Colors Are Uneven .....                                    | 152 |
| Mixing the Ink by Shaking the Pouch Tray .....                | 152 |

# Cleaning the Machine

## Cleaning the Media Path

Wipe away any ink or grime on the media path and other areas as part of the daily cleaning procedure. It is easy for ink or grime to affix to the media path, and, if left unattended, this will contaminate new media and have a negative effect on the transport of media when it is output. Pinch rollers, grit rollers, and the platen are particularly prone to the buildup of grime.

**⚠ WARNING** Never use a solvent such as gasoline, alcohol, or thinner to perform cleaning. Doing so may cause a fire.

**⚠ CAUTION** Before attempting cleaning, switch off the sub power and wait until the platen and dryer cool (approximately 30 minutes).

Sudden movement of the machine may cause injury, or hot components may cause burns.

### IMPORTANT

- This machine is a precision device and is sensitive to dust and dirt. Perform cleaning on a daily basis.
- Never attempt to oil or lubricate the machine.

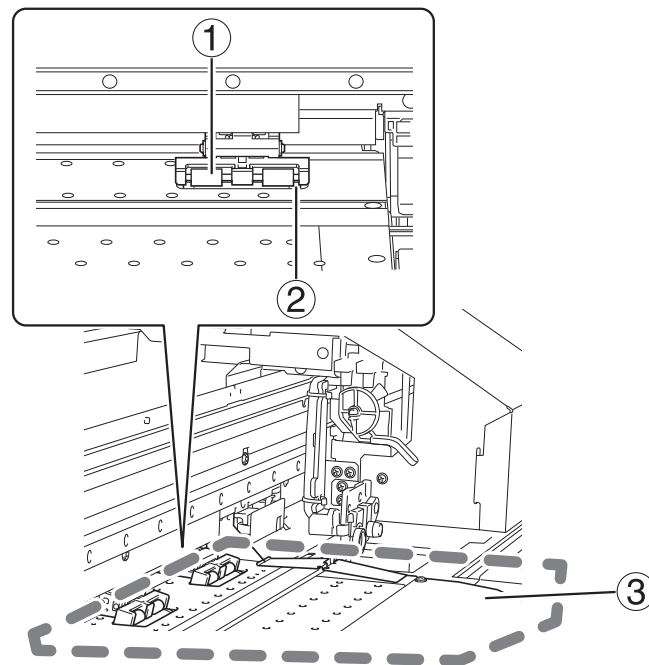

Clean by wiping with a cloth moistened by neutral detergent diluted with water then wrung dry.

|   |              |                                                                                                                                                                                                                                         |
|---|--------------|-----------------------------------------------------------------------------------------------------------------------------------------------------------------------------------------------------------------------------------------|
| ① | Pinch roller | These are the positions where the media is fixed in place or transported, so it is easy for ink and grime to affix to these positions. Failure to clean this part properly may result in the transfer of grime to the surface of media. |
| ② | Grit roller  | These are the positions where the media is fixed in place or transported, so it is easy for grime to affix to these positions. Remove buildup of media scraps and other material using a brush. Never use a metal brush.                |
| ③ | Platen       | Wipe away any buildup of ink, grime, or cut media on the media path and in the grooves.                                                                                                                                                 |

## Cleaning the Knife Carriage Roller

Paper dust affixes to the separating knife carriage roller during media separation. Periodically wipe the area clean.

**⚠ WARNING** Never use a solvent such as gasoline, alcohol, or thinner to perform cleaning. Doing so may cause a fire.

**⚠ CAUTION** Before attempting cleaning, switch off the sub power and wait until the platen and dryer cool (approximately 30 minutes). Sudden movement of the machine may cause injury, or hot components may cause burns.

### IMPORTANT

- This machine is a precision device and is sensitive to dust and dirt. Perform cleaning on a daily basis.
- Never attempt to oil or lubricate the machine.

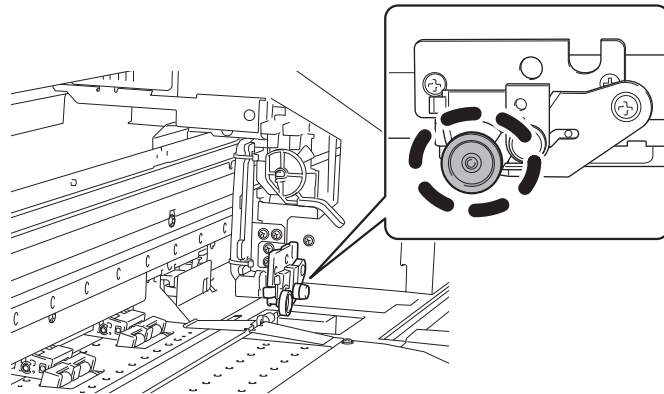

Clean by wiping with a cloth moistened by neutral detergent diluted with water then wrung dry.

# Disposing of Discharged Fluid

## Precautions for Disposing of Discharged Fluid

**⚠ WARNING**

Never place discharged fluid or ink near an open flame. Doing so may cause a fire.

**⚠ CAUTION**

To store discharged fluid temporarily, place it in the included drain bottle or in a durable sealed container such as a metal can or polyethylene tank, and cap tightly.

Any spillage or vapor leakage may cause fire, odor, or physical distress.

**IMPORTANT**

Do not store discharged fluid in a location where it is exposed to direct sunlight.

When temporarily storing discharged fluid in the included drain bottle, do not store it in a location that is exposed to direct sunlight. The discharged fluid may harden, making the drain bottle unusable. The drain bottle may also deteriorate, leading to discharged fluid leaks.

**IMPORTANT**

Dispose of discharged fluid properly, in accordance with the laws in effect in your locale.

Discharged fluid is flammable and contains toxic ingredients. Never attempt to incinerate discharged fluid or discard it with ordinary trash. Also, do not dispose of it in sewer systems, rivers, or streams. Doing so may have an adverse impact on the environment.

## If the Discharged Fluid Disposal Message Appears

The message shown below appears when a certain amount of discharged fluid has collected in the bottle. If this message appears, dispose of the discharged fluid.

```
EMPTY
DRAIN BOTTLE ↵
```

### Procedure

1. When the following message appears, press [ENTER].

```
EMPTY
DRAIN BOTTLE ↵
```

2. When the screen shown below appears, remove the drain bottle and discard the discharged fluid.

```
NOW EMPTY? ◀ ▶
[YES] NO ↵
```



### ⚠ CAUTION

Before you detach the drain bottle, be sure to wait for the screen to display "EMPTY DRAIN BOTTLE". After discarding the discharged fluid, promptly attach the drain bottle to the machine.

Failing to follow this procedure may cause discharged fluid to flow out of the tube and spill, soiling your hands or the floor.

### IMPORTANT

When you remove the drain bottle, a few drops of discharged fluid may come out of the machine. Exercise caution to prevent this fluid from soiling your hands or the floor.

3. Quickly attach the emptied drain bottle to the machine once more.
4. Press [◀] or [▶] to select "YES".

```
NOW EMPTY? ◀ ▶
[YES] NO ↵
```

5. Press [ENTER] to confirm your entry.

The display returns to the original screen.

### MEMO

If you did not discard the discharged fluid and selected "NO"

The display also returns to the original screen if you did not discard the discharged fluid and selected "NO". In this case the "NOW EMPTY?" message disappears temporarily. The message appears again once a certain amount of discharged fluid has collected.

### ⚠ CAUTION

When the message "NOW EMPTY?" appears on the screen, discard as much of the discharged fluid as possible.

Repeatedly selecting "NO" without discarding the discharged fluid may cause it to spill out of the drain bottle, soiling your hands or the floor.



## If the Drain Bottle Exceeds Its Capacity Limit

The drain bottle collects discharged fluid. You can dispose of discharged fluid even if the message "EMPTY DRAIN BOTTLE" is not displayed on the screen. Discard the discharged fluid before the drain bottle exceeds its capacity limit.

### Procedure

1. Press [MENU].
2. Press [▼] several times to display the screen shown below.

```
MENU ◀◆
SUB MENU ▶
```

3. Press [▶] once, and then press [▼] several times to display the screen shown below.

```
SUB MENU ◀◆
MAINTENANCE ▶
```

4. Press [▶] once, and then press [▼] several times to display the screen shown below.

```
MAINTENANCE ◀◆
DRAIN BOTTLE ◀
```

5. Press [ENTER].

6. When the screen shown below appears, remove the drain bottle and discard the discharged fluid.

```
EMPTY ◀
DRAIN BOTTLE ◀
```



### ⚠ CAUTION

Before you detach the drain bottle, be sure to wait for the screen to display "EMPTY DRAIN BOTTLE". After discarding the discharged fluid, promptly attach the drain bottle to the machine.

Failing to follow this procedure may cause discharged fluid to flow out of the tube and spill, soiling your hands or the floor.

### IMPORTANT

When you remove the drain bottle, a few drops of discharged fluid may come out of the machine. Exercise caution to prevent this fluid from soiling your hands or the floor.

7. Quickly attach the emptied drain bottle to the machine once more.
8. Press [ENTER].

```
EMPTY ◀
DRAIN BOTTLE ◀
```

9. Press [ENTER].

```
RESET DRAIN
COUNTER◀
```

10. Press [MENU] to go back to the original screen.

# Daily Print Head Check

## Printing Tests and Normal Cleaning

### 1. Perform a printing test.

Before you carry out actual printing, perform a printing test to ensure no dot drop-out or dot displacement occurs. If dot drop-out or dot displacement occurs, perform cleaning of the print heads (normal cleaning).

#### MEMO

When performing printing tests successively, you can select "FEED" (vertical printing) or "SCAN" (horizontal printing) as the print position for the second and later tests in comparison to the first test.

#### Procedure

1. Load the media.  
● P. 28 "Setup of Media"
2. Press [FUNCTION].
3. Press [▼], then [▶] to display the screen shown below.



4. Press [ENTER].  
Printing of the test pattern starts.
5. Check whether there is dot drop-out or dot displacement in the test pattern.  
Missing blocks indicate dot drop-out. Collapsed or inclined blocks indicate dot displacement.

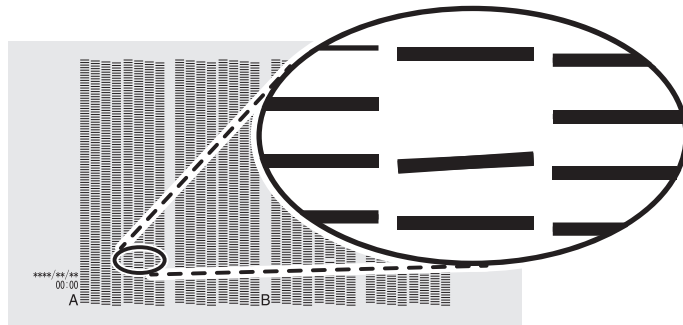

6. If you have opened the front cover, close it.  
If no dot drop-out or dot displacement occurs, this operation is finished. Press [FUNCTION] to go back to the original screen.

## 2. Perform normal cleaning.

### Procedure

1. Press [▼] to display the screen shown below.

```
CLEANING ◀◆▶
NORMAL CL. ▶
```

2. Check for the group with dot drop-out or dot displacement by viewing the results of the printing test. The space from "A" to "B" is group A. The space from "B" to the right side is group B.

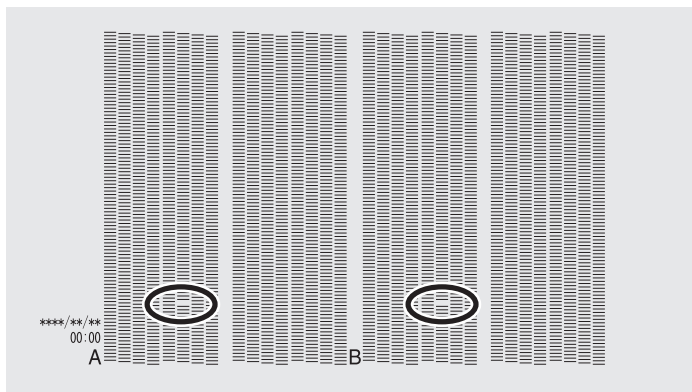

### MEMO

If the printing-test results are difficult to interpret

Check the results in a bright location, changing your line of vision. They are visible using the reflection of the light.

3. Press [▶].
4. Select the group of print heads to clean.
  - (1) Press [◀] or [▶] to select the group of print heads that is not to be cleaned.

```
NORMAL CL. ◀◆▶
AB ◀
```

- (2) Press [▲] or [▼] to get rid of the group display.

```
NORMAL CL. ◀◆▶
A_ ◀
```

- (3) Repeat steps 1 and 2 to display only the group of print heads that requires cleaning.

Only the displayed groups will be cleaned. If "AB" is displayed, both groups will be cleaned.

5. Press [ENTER] to confirm your entry.

The screen shown below appears, and then cleaning starts. The (approximate) remaining time for the procedure is displayed on the screen. (The display shown below is an example. "01:45" = "1 minute and 45 seconds")

```
CLEANING...
>> 01:45
```

When finished, the screen shown below appears again.

```
NORMAL CL. ◀◆▶
AB ◀
```

6. Press [◀] several times to display the screen shown below.

---

|            |    |
|------------|----|
| CLEANING   | ◀◆ |
| NORMAL CL. | ▶  |

7. Press [▲] to display the screen shown below.

|            |    |
|------------|----|
| CLEANING   | ◀◆ |
| TEST PRINT | ↵  |

8. Press [ENTER].

Perform a printing test again to check whether the dot drop-out and dot displacement have been corrected.

9. Check to make sure the dot drop-out or dot displacement has been corrected.

If the problem persists, try performing normal cleaning again. If the printer has been used for a long period, dot drop-outs may not be fixed even after performing normal cleaning two or three times. If this is the case, clean using a different method.

#### RELATED LINKS

---

- P. 140 "When Normal Cleaning Is Not Effective"
-

# When Normal Cleaning Is Not Effective

## Medium Cleaning Method

The print heads are important components that discharge ink. They require periodic and appropriate maintenance. When problems such as dot drop-out are not resolved by normal cleaning, perform the more forceful "medium cleaning" to remove clogging from the print heads.

### IMPORTANT

Medium cleaning consumes more ink than normal cleaning, and overly frequent use may damage the print heads themselves. Avoid performing this operation more than necessary.

### Procedure

1. Load the media.  
    ➤ P. 28 "Setup of Media"
2. Press [FUNCTION].
3. Press [▼], then [▶] to display the screen shown below.

```
CLEANING ◀◆
TEST PRINT ⏏
```

4. Press [ENTER].  
    A test pattern is printed.
5. Press [▼] several times to display the screen shown below.

```
CLEANING ◀◆
MEDIUM CL. ▶
```

6. Press [▶] to display the screen shown below.

```
MEDIUM CL. ◀◆▶
 AB ⏏
```

7. Check for the group with dot drop-out or dot displacement by viewing the results of the printing test.  
    The space from "A" to "B" is group A. The space from "B" to the right side is group B.

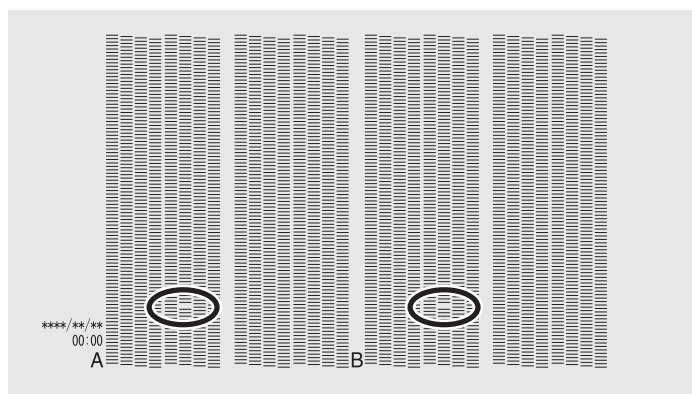

### MEMO

If the printing-test results are difficult to interpret

Check the results in a bright location, changing your line of vision. They are visible using the reflection of the light.

8. Select the group of print heads to clean.  
    (1) Press [◀] or [▶] to select the group of print heads that is not to be cleaned.

```

MEDIUM CL. ◀◆▶
 AB ↵

```

- (2) Press [▲] or [▼] to get rid of the group display.

```

MEDIUM CL. ◀◆▶
 A_ ↵

```

- (3) Repeat steps 1 and 2 to display only the group of print heads that requires cleaning.

Only the displayed groups will be cleaned. If "AB" is displayed, both groups will be cleaned.

- 9.** Press [ENTER] to confirm your entry.

The screen shown below appears, and then cleaning starts. The (approximate) remaining time for the procedure is displayed on the screen. (The display shown below is an example. "01:45" = "1 minute and 45 seconds")

```

CLEANING...
>> 01:45

```

When finished, the screen shown below appears again.

```

MEDIUM CL. ◀◆▶
 AB ↵

```

- 10.** Press [◀] several times to display the screen shown below.

```

CLEANING ◀◆
MEDIUM CL. ▶

```

- 11.** Press [▼] several times to display the screen shown below.

```

CLEANING ◀◆
TEST PRINT ↵

```

- 12.** Press [ENTER].

Perform a printing test again to check whether the dot drop-out and dot displacement have been corrected.

#### MEMO

- If the problem persists, try performing medium cleaning again.
- If problems such as dot drop-out and dot displacement persist even after you have performed medium cleaning several times, perform "powerful cleaning."
- This cleaning can be effective when carried out periodically, according to the frequency of use.

#### RELATED LINKS

- P. 142 "Powerful Cleaning Method"

## Powerful Cleaning Method

The print heads are important components that discharge ink. They require periodic and appropriate maintenance. When problems such as dot drop-out are not resolved by medium cleaning, perform the more forceful "powerful cleaning" to remove clogging from the print heads.

### IMPORTANT

Powerful cleaning consumes more ink than medium cleaning, and overly frequent use may damage the print heads themselves. Avoid performing this operation more than necessary.

### Procedure

1. Load the media.  
 Ⓞ P. 28 "Setup of Media"
2. Press [FUNCTION].
3. Press [▼], then [▶] to display the screen shown below.

```
CLEANING ◀◆
TEST PRINT ↵
```

4. Press [ENTER].  
 A test pattern is printed.
5. Press [▼] several times to display the screen shown below.

```
CLEANING ◀◆
POWERFUL CL. ▶
```

6. Press [▶] to display the screen shown below.

```
POWERFUL CL. ◀◆▶
 AB ↵
```

7. Check for the group with dot drop-out or dot displacement by viewing the results of the printing test.  
 The space from "A" to "B" is group A. The space from "B" to the right side is group B.

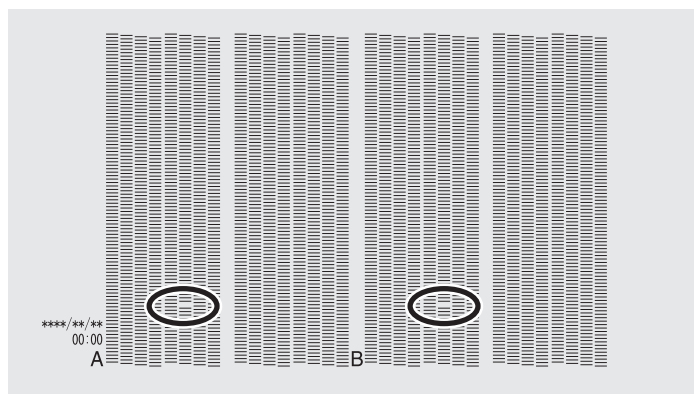

### MEMO

If the printing-test results are difficult to interpret

Check the results in a bright location, changing your line of vision. They are visible using the reflection of the light.

8. Select the group of print heads to clean.
  - (1) Press [◀] or [▶] to select the group of print heads that is not to be cleaned.

```
POWERFUL CL. ◀◆▶
 AB ↵
```

- (2) Press [▲] or [▼] to get rid of the group display.

```

POWERFUL CL. ◀▶▶
A_ ↵

```

- (3) Repeat steps 1 and 2 to display only the group of print heads that requires cleaning.

Only the displayed groups will be cleaned. If "AB" is displayed, both groups will be cleaned.

9. Press [ENTER] to confirm your entry.

The screen shown below appears, and then cleaning starts. The (approximate) remaining time for the procedure is displayed on the screen. (The display shown below is an example. "01:45" = "1 minute and 45 seconds")

```

CLEANING...
>> 01:45

```

When finished, the screen shown below appears again.

```

POWERFUL CL. ◀▶▶
AB ↵

```

10. Press [◀] several times to display the screen shown below.

```

CLEANING ◀▶
POWERFUL CL. ▶

```

11. Press [▼] several times to display the screen shown below.

```

CLEANING ◀▶
TEST PRINT ↵

```

12. Press [ENTER].

Perform a printing test again to check whether the dot drop-out and dot displacement have been corrected.

#### MEMO

- If the problem persists, try performing powerful cleaning again.
- This cleaning can be effective when carried out periodically, according to the frequency of use.
- If problems such as dot drop-out and dot displacement persist even after you have performed powerful cleaning several times, perform "manual cleaning."

#### RELATED LINKS

---

- P. 145 "Manual Cleaning Method"
-



# Manual Cleaning

## When Manual Cleaning Is Necessary

The print heads are important components that discharge ink. They require periodic and appropriate maintenance. It is important to perform manual cleaning with the appropriate timing.

### When a Message Appears

The following message appears periodically. When this message is displayed, be sure to perform manual cleaning.



### When Symptoms That Cannot Be Improved with Powerful Cleaning Occur

When any of the symptoms given below occur and powerful cleaning is not effective, perform manual cleaning.

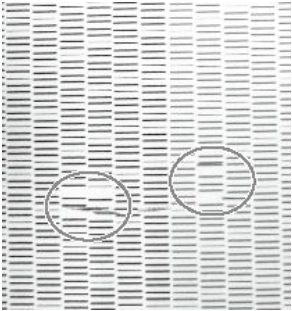
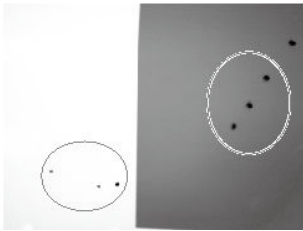
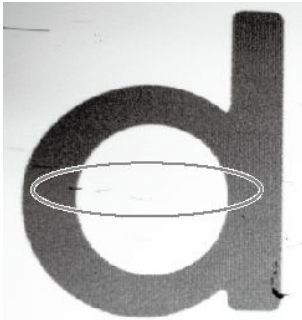
| Dot drop-out/Dot displacement                                                              | Ink drips                                                                          | Dragging dirt                                                                        |
|--------------------------------------------------------------------------------------------|------------------------------------------------------------------------------------|--------------------------------------------------------------------------------------|
|          |  |  |
| Dust or other foreign matter adheres to the print heads and impedes correct ink discharge. | Ink pools in dust or dirt adhered to the print heads, and drips onto the media.    | The phenomenon where dirt or dust accumulates on the print heads.                    |

#### MEMO

Wiper replacement may also be effective in improving these symptoms.

#### RELATED LINKS

- P. 166 "Replacing the Wiper and the Tray Pad"

## Manual Cleaning Method

If the message "TIME FOR MAINTENANCE" is displayed or if dot drop-out or ink drip issues that cannot be improved with powerful cleaning occur, perform manual cleaning.

- ⚠ WARNING** Be sure to perform operations as specified by the instructions, and never touch any area not specified in the instructions.  
Sudden movement of the machine may cause injury.



### IMPORTANT

#### Important notes on this procedure

- Before attempting this operation, remove any media.
- To prevent the print heads from drying out, finish this procedure in 30 minutes or less. A warning beep sounds after 30 minutes.
- Never use any implements other than the included cleaning sticks. Cotton swabs or other lint-producing items may damage the print heads.
- Use only the included cleaning liquid.
- Use one cleaning stick per cleaning session, and then discard the stick after use. Reusing cleaning sticks will adversely affect the printing results.
- Do not put a cleaning stick that has been used for cleaning into the cleaning liquid. Doing so will deteriorate the cleaning liquid.
- Never rub the print head surface (nozzle surface).
- If you use up the cleaning sticks or cleaning liquid, contact your authorized Roland DG Corporation dealer or visit our website (<http://www.rolanddg.com/>).

#### If a warning beep sounds during cleaning

- A warning beep sounds 30 minutes after operation starts. Stop work, close all the covers, and then press [ENTER] to end the manual cleaning mode. After that, restart the procedure from the beginning.

| Required items                                                                      |                                                                                     |
|-------------------------------------------------------------------------------------|-------------------------------------------------------------------------------------|
|  |  |
| Cleaning sticks                                                                     | Cleaning liquid                                                                     |

## 1. Clean the print head caps.

### Procedure

1. Remove any media.
2. Press [FUNCTION].
3. Press [▶] once, and then press [▼] several times to display the screen shown below.

```
CLEANING ◀◆
MANUAL CL. ↵
```

4. Press [ENTER].

"NOW PROCESSING.." is displayed and the print head moves to the left end of the platen. After that, the screen shown below appears.

```
FINISHED? ↵
```

### IMPORTANT

Do not press [ENTER] at this stage. Press [ENTER] after cleaning is complete. If you press [ENTER] at this stage, wait for the screen to change as shown in the following figure, and then press [ENTER] again.

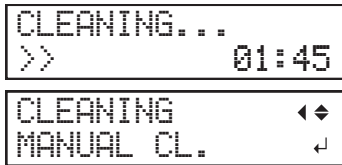

5. Open the right cover.

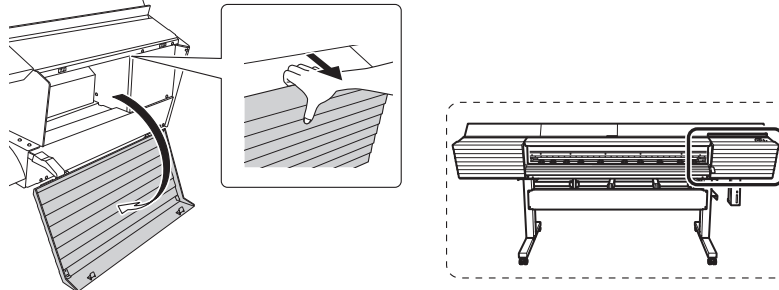

6. Touch the location shown in the figure to discharge any static electricity.

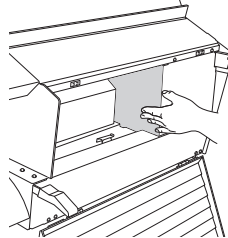

7. Moisten the cleaning stick with the cleaning liquid.

**IMPORTANT**

Be sure to use one of the included cleaning sticks.



8. Clean the locations shown in the following figure.

Be especially careful to clean away any fibrous dust (lint).

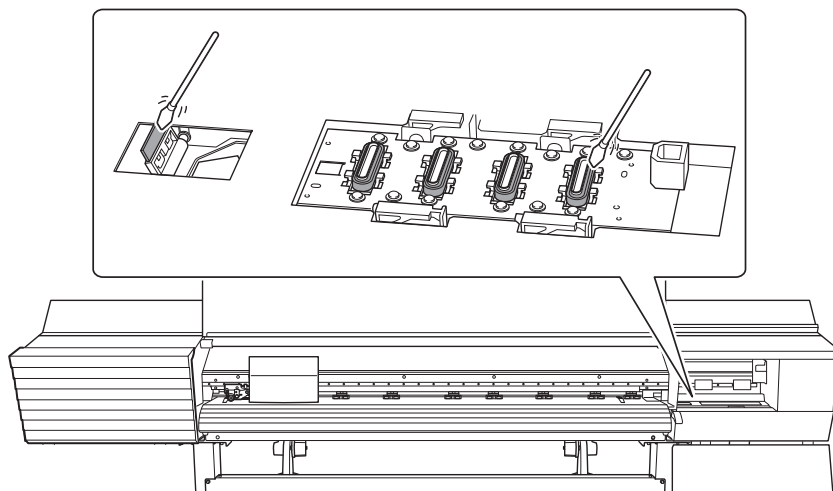

9. When you have finished cleaning, close the right cover.

## 2. Clean the print heads.

### Procedure

1. Open the front cover.
2. Open the left cover.

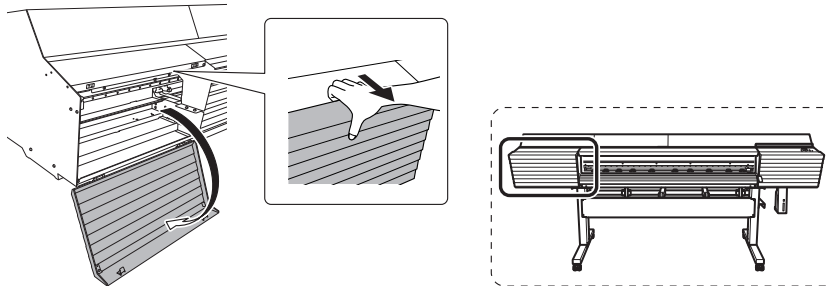

3. Remove the cut rail.

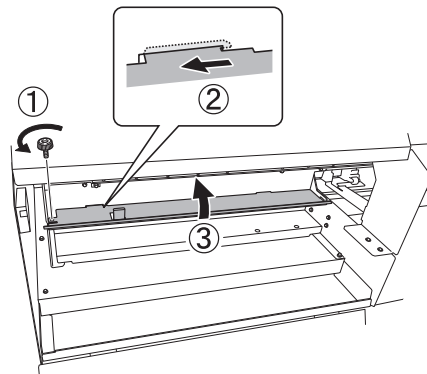

4. Move the print-head carriage to the position where the cut rail was present.

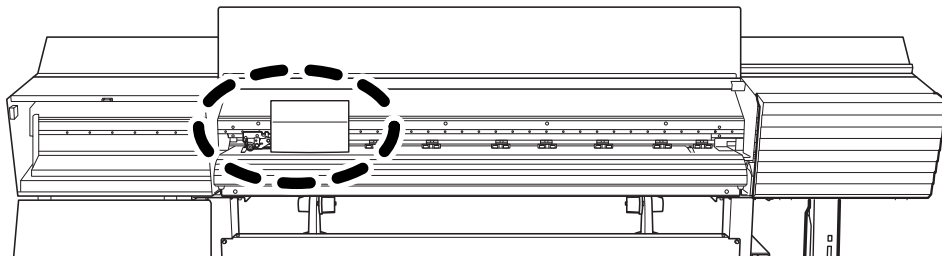

Move it by pushing the position indicated with (1) in the following figure.

- ⚠ CAUTION** When moving the print-head carriage by hand, be sure to hold the specified position.  
Moving it by holding positions other than those specified may deform and damage the cover.

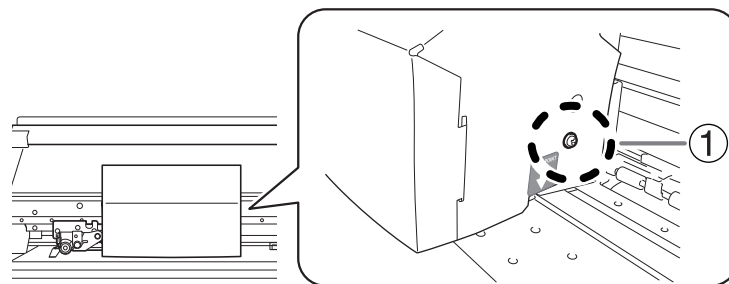

5. Moisten the cleaning stick with the cleaning liquid.

**IMPORTANT**

Be sure to use one of the included cleaning sticks.



6. Clean the locations shown in the following figure.  
Be especially careful to clean away any fibrous dust (lint).

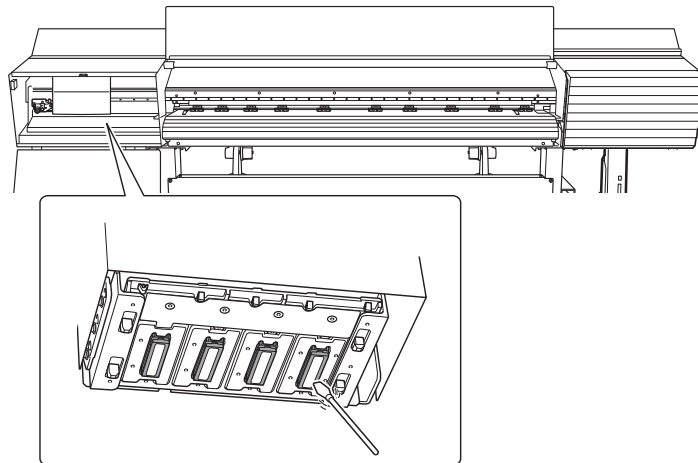

7. When you have finished cleaning, move the print-head carriage to above the platen.

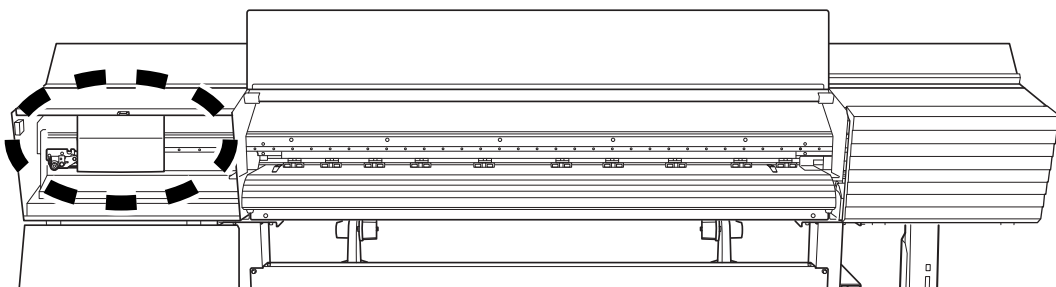

Move it by pushing the position indicated with (1) in the following figure.

**⚠ CAUTION** When moving the print-head carriage by hand, be sure to hold the specified position.  
Moving it by holding positions other than those specified may deform and damage the cover.

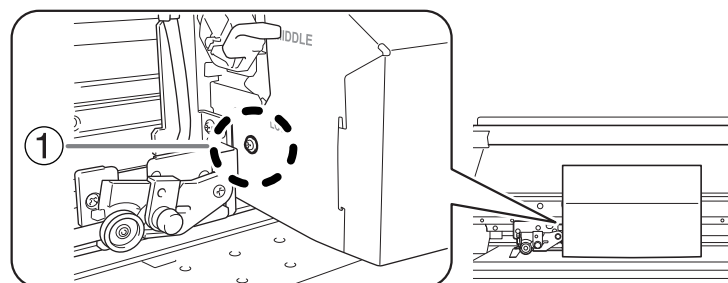

8. Attach the cut rail.

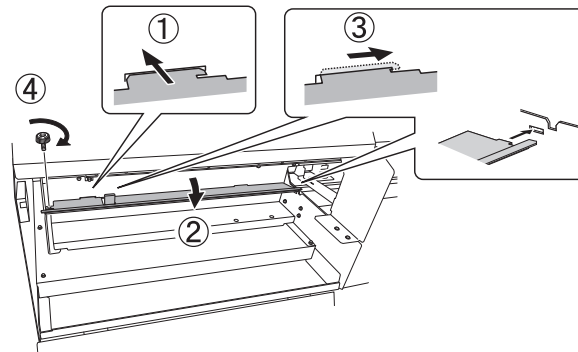

9. Close the left cover.
10. Close the front cover.
11. Press [ENTER].

```

FINISHED?
└─┬─┘

```

The screen shown below appears, and then cleaning starts. The (approximate) remaining time for the procedure is displayed on the screen. (The display shown below is an example. "01:45" = "1 minute and 45 seconds")

```

CLEANING...
>> 01:45

```

When cleaning finishes, the screen shown below appears again.

```

CLEANING ◀▶
MANUAL CL. └─┬─┘

```

12. Press [FUNCTION] to go back to the original screen.

---

### 3. Perform a printing test to check the results.

---

**Procedure**

1. Load the media.  
    ➤ P. 28 "Setup of Media"
2. Press [FUNCTION].
3. Press [▼], then [▶] to display the screen shown below.



4. Press [ENTER].  
    Printing of the test pattern starts.
5. Check whether there is dot drop-out or dot displacement in the test pattern.  
    Missing blocks indicate dot drop-out. Collapsed or inclined blocks indicate dot displacement.

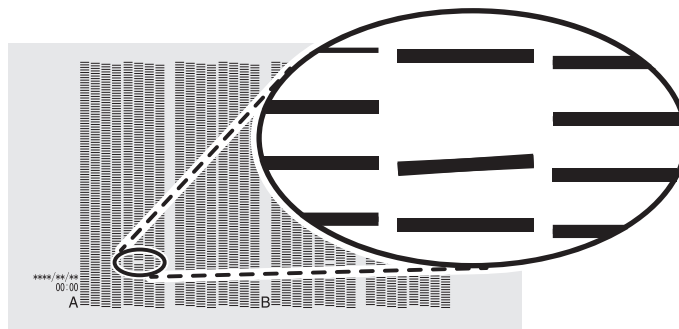

6. If you have opened the front cover, close it.  
    If no dot drop-out or dot displacement occurs, this operation is finished. Press [FUNCTION] to go back to the original screen.

---

**RELATED LINKS**

- P. 137 "Printing Tests and Normal Cleaning"
  - P. 140 "Medium Cleaning Method"
  - P. 142 "Powerful Cleaning Method"
-

---

## Consumable Products and Parts Related to Manual Cleaning

The cleaning sticks, cleaning liquid, and print heads are consumable products or consumable parts.

- If you use up the cleaning sticks and cleaning liquid used for manual cleaning, contact your authorized Roland DG Corporation dealer or visit our website (<http://www.rolanddg.com/>).
- The print heads are components that wear out. Periodic replacement is required, with the frequency of replacement depending on use. Contact your authorized Roland DG Corporation dealer.



# If Colors Are Uneven

## Mixing the Ink by Shaking the Pouch Tray

If ink components precipitate in the ink pouch, colors may be uneven (unevenness in printed colors). If colors are uneven, remove the pouch trays, and then shake them gently.

So that the ink mixes well, shake the pouch tray horizontally 50 times (about 20 seconds) with a stroke length of around 5 cm (2 in.) from each end of the tray.

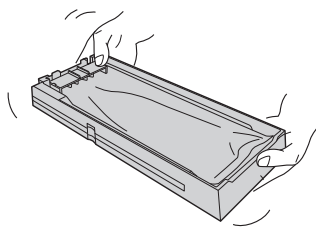

Shake the pouch trays:

- Once per week (for all the inks).
- After inserting a new ink pouch (for all the inks).
- Before starting the day's operations (for just the white ink).

### MEMO

To prevent ink precipitation, you can make the machine periodically display a message prompting you to mix the ink.

➤ P. 119 "Thoroughly Mixing the Ink Periodically"

### IMPORTANT

- Do not remove the ink pouches. Shake the entire pouch tray. Removing the ink pouches may lead to the ink leaking.
- Before shaking, wipe off any ink from around the mouth of the ink pouch. If you do not wipe off the ink, it may splatter when you shake the pouch tray.
- When you have finished mixing the ink, reinsert the pouch tray immediately. Taking time to reattach the ink cartridge will adversely affect the ink path.

If uneven color issues are not resolved even after shaking the pouch trays to mix the ink, perform "damper cleaning" or "super cleaning."

| Colors for which uneven color issues remain                                         | Cleaning to perform               |
|-------------------------------------------------------------------------------------|-----------------------------------|
| White                                                                               | ➤ P. 154 "Damper Cleaning Method" |
| Cyan, magenta, yellow, black, light cyan, light magenta, light black, orange, green | ➤ P. 157 "Super Cleaning Method"  |

# Advanced Maintenance

---

|                                                               |     |
|---------------------------------------------------------------|-----|
| When Uneven Color Issues Occur with White Ink .....           | 154 |
| Damper Cleaning Method .....                                  | 154 |
| Handling Severe Dot Drop-out and Dot Displacement .....       | 157 |
| Super Cleaning Method .....                                   | 157 |
| Partially Restricting the Print Heads Used for Printing ..... | 162 |
| Emergency Measure) Cleaning the Print Head Surface .....      | 164 |

# When Uneven Color Issues Occur with White Ink

## Damper Cleaning Method

If uneven color issues with white ink are not resolved even after shaking the pouch trays to mix the ink, perform "damper cleaning." Uneven colors refers to the symptom of printed colors being uneven (such as the color density being inconsistent) even when the same data is printed with the same settings.

Damper cleaning can be used to stabilize the printed colors by agitating the ink.

### IMPORTANT

- Damper cleaning consumes a lot of ink, and overly frequent use may damage the print heads themselves. Avoid performing this operation more than necessary.
- When you perform damper cleaning, replace the Lc, Lm, Lk, Or, Gr, and Wh inks with new ink pouches. If the ink runs out during cleaning, a "CLEANING ERROR" will occur and cleaning will stop.
  - The ink pouch that you have removed can still be used in operations other than damper cleaning (such as printing).

### Procedure

1. Press [MENU].
2. Press [▼] several times to display the screen shown below.

```
MENU ◀◆
SUB MENU ▶
```

3. Press [▶] once, and then press [▼] several times to display the screen shown below.

```
SUB MENU ◀◆
INK CONTROL ▶
```

4. Press [▶] once, and then press [▼] several times to display the screen shown below.

```
INK CONTROL ◀◆
DAMPER CL. ◀
```

5. Press [ENTER].

The screen shown below appears. The ink slot whose LED is flashing is the target for ink replacement.

```
CHANGE TO NEW ◀
INK CARTRIDGE ◀
```

6. Replace the Lc, Lm, Lk, Or, Gr, and Wh inks with new ink pouches.

### IMPORTANT

There is no need to replace the C, M, Y, and K inks.

➤ P. 48 "Ink Pouch Replacement"

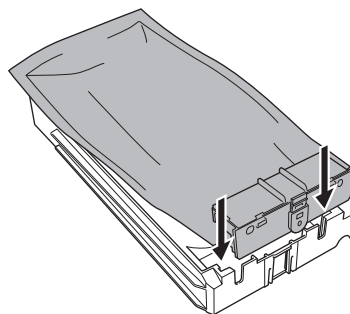

7. Press [ENTER].

The screen shown below appears, and then cleaning starts. The (approximate) remaining time for the procedure is displayed on the screen. (The display shown below is an example. "01:45" = "1 minute and 45 seconds")

```
CLEANING...
>> 01:45
```

**MEMO**

When "EMPTY DRAIN BOTTLE" is displayed during cleaning

```
EMPTY
DRAIN BOTTLE↵
```



1. Remove the drain bottle and discard the discharged fluid.
2. Quickly attach the emptied drain bottle to the machine once more.
3. Press [ENTER].

**IMPORTANT**

When you remove the drain bottle, a few drops of discharged fluid may come out of the machine. Exercise caution to prevent this fluid from soiling your hands or the floor.

- ⚠ CAUTION** When "EMPTY DRAIN BOTTLE" appears on the screen, be sure to discard the discharged fluid.  
Failing to discard the discharged fluid when "EMPTY DRAIN BOTTLE" is displayed will lead to the discharged fluid overflowing during cleaning.
- ⚠ CAUTION** Before you detach the drain bottle, be sure to wait for the screen to display "EMPTY DRAIN BOTTLE". After discarding the discharged fluid, promptly attach the drain bottle to the machine.  
Failing to follow this procedure may cause discharged fluid to flow out of the tube and spill, soiling your hands or the floor.
- ⚠ WARNING** Never place discharged fluid or ink near an open flame.  
Doing so may cause a fire.
- ⚠ CAUTION** To store discharged fluid temporarily, place it in the included drain bottle or in a durable sealed container such as a metal can or polyethylene tank, and cap tightly.  
Any spillage or vapor leakage may cause fire, odor, or physical distress.

**IMPORTANT**

Do not store discharged fluid in a location where it is exposed to direct sunlight.

When temporarily storing discharged fluid in the included drain bottle, do not store it in a location that is exposed to direct sunlight. The discharged fluid may harden, making the drain bottle unusable. The drain bottle may also deteriorate, leading to discharged fluid leaks.

**IMPORTANT**

Dispose of discharged fluid properly, in accordance with the laws in effect in your locale.

Discharged fluid is flammable and contains toxic ingredients. Never attempt to incinerate discharged fluid or discard it with ordinary trash. Also, do not dispose of it in sewer systems, rivers, or streams. Doing so may have an adverse impact on the environment.

When cleaning finishes, the screen shown below appears again.

```
INK CONTROL ◀◆
DAMPER CL. ↵
```

8. Press [MENU] to go back to the original screen.

If uneven color issues with white ink are not resolved by "damper cleaning," perform "super cleaning."

RELATED LINKS

---

- P. 157 "Super Cleaning Method"
  - P. 200 ""CLEANING ERROR""
-

# Handling Severe Dot Drop-out and Dot Displacement

## Super Cleaning Method

In the following cases, perform "super cleaning."

- If ink discharge issues such as dot drop-out are not corrected after performing cleaning using the cleaning function (normal, medium, powerful) or manual cleaning.
- If white is uneven even after performing damper cleaning.
  - P. 154 "Damper Cleaning Method"
- If colors other than white (cyan, magenta, yellow, black, light cyan, light magenta, light black, orange, or green) are uneven even after shaking the pouch trays to mix the ink.
  - P. 152 "Mixing the Ink by Shaking the Pouch Tray"

### IMPORTANT

A large amount of ink will be discharged during super cleaning. Perform this operation only when ink discharge issues such as dot drop-out, dot displacement, and uneven colors cannot be corrected even after performing cleaning using the other cleaning functions (normal, medium, powerful, manual, and damper cleaning).

### RELATED LINKS

- P. 137 "Printing Tests and Normal Cleaning"
- P. 140 "Medium Cleaning Method"
- P. 142 "Powerful Cleaning Method"
- P. 144 "Manual Cleaning"
- P. 154 "Damper Cleaning Method"
- P. 152 "Mixing the Ink by Shaking the Pouch Tray"

## 1. Perform a printing test.

### Procedure

1. Load the media.
  - P. 28 "Setup of Media"
2. Press [FUNCTION].
3. Press [▼], then [▶] to display the screen shown below.



4. Press [ENTER].  
Printing of the test pattern starts.
5. Check whether there is dot drop-out or dot displacement in the test pattern.  
Missing blocks indicate dot drop-out. Collapsed or inclined blocks indicate dot displacement.

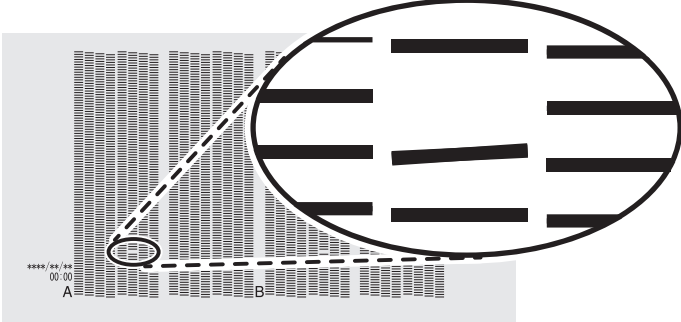

6. If you have opened the front cover, close it.

## 2. Start the super cleaning menu.

### Procedure

1. Press [MENU].
2. Press [▼] several times to display the screen shown below.

```
MENU ◀◆
SUB MENU ▶
```

3. Press [▶] once, and then press [▼] several times to display the screen shown below.

```
SUB MENU ◀◆
INK CONTROL ▶
```

4. Press [▶] to display the screen shown below.

```
INK CONTORL ◀◆
SUPER CL. ▶
```

5. Press [▶].
6. Check for the group with dot drop-out or dot displacement by viewing the results of the printing test. The space from "A" to "B" is group A. The space from "B" to the right side is group B.

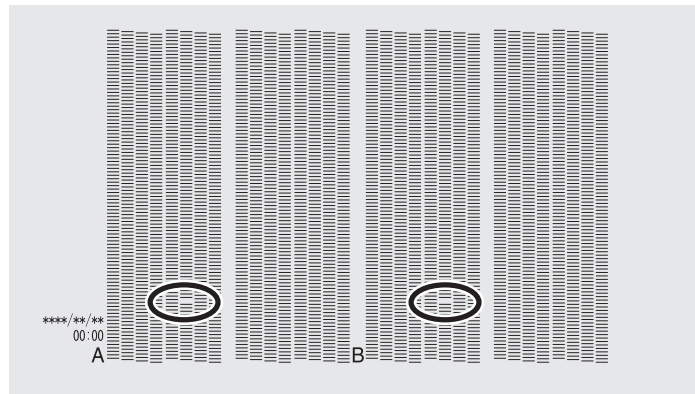

### MEMO

If the printing-test results are difficult to interpret

Check the results in a bright location, changing your line of vision. They are visible using the reflection of the light.

7. Select the group of print heads to clean.
  - (1) Press [◀] or [▶] to select the group of print heads that is not to be cleaned.

```
SUPER CL. ◀◆▶
 AB ↵
```

- (2) Press [▲] or [▼] to get rid of the group display.

```
SUPER CL. ◀◆▶
 A_ ↵
```

- (3) Repeat steps 1 and 2 to display only the group of print heads that requires cleaning. Only the displayed groups will be cleaned. If "AB" is displayed, both groups will be cleaned.

8. Press [ENTER] to confirm your entry.
9. When the screen shown below appears, remove the drain bottle and discard the discharged fluid.



```
EMPTY
DRAIN BOTTLE ↵
```



- ⚠ CAUTION** Before you detach the drain bottle, be sure to wait for the screen to display "EMPTY DRAIN BOTTLE". After discarding the discharged fluid, promptly attach the drain bottle to the machine.
- Failing to follow this procedure may cause discharged fluid to flow out of the tube and spill, soiling your hands or the floor.

### IMPORTANT

When you remove the drain bottle, a few drops of discharged fluid may come out of the machine. Exercise caution to prevent this fluid from soiling your hands or the floor.

- 10.** Quickly attach the emptied drain bottle to the machine once more.

- 11.** Press [ENTER].

```
EMPTY
DRAIN BOTTLE ↵
```

- ⚠ WARNING** Never place discharged fluid or ink near an open flame. Doing so may cause a fire.
- ⚠ CAUTION** To store discharged fluid temporarily, place it in the included drain bottle or in a durable sealed container such as a metal can or polyethylene tank, and cap tightly.
- Any spillage or vapor leakage may cause fire, odor, or physical distress.

### IMPORTANT

Do not store discharged fluid in a location where it is exposed to direct sunlight.

When temporarily storing discharged fluid in the included drain bottle, do not store it in a location that is exposed to direct sunlight. The discharged fluid may harden, making the drain bottle unusable. The drain bottle may also deteriorate, leading to discharged fluid leaks.

### IMPORTANT

Dispose of discharged fluid properly, in accordance with the laws in effect in your locale.

Discharged fluid is flammable and contains toxic ingredients. Never attempt to incinerate discharged fluid or discard it with ordinary trash. Also, do not dispose of it in sewer systems, rivers, or streams. Doing so may have an adverse impact on the environment.

The screen shown below appears, and then cleaning starts. The (approximate) remaining time for the procedure is displayed on the screen. (The display shown below is an example. "01:45" = "1 minute and 45 seconds")

```
CLEANING...
>> 01:45
```

When finished, the screen shown below appears again.

```
SUPER CL. ◀▶▶
 AB ↵
```

- 12.** Press [MENU] to go back to the original screen.

### 3. Perform a printing test to check the results.

#### Procedure

1. Load the media.  
 ● P. 28 "Setup of Media"
2. Press [FUNCTION].
3. Press [▼], then [▶] to display the screen shown below.



4. Press [ENTER].  
 Printing of the test pattern starts.
5. Check whether there is dot drop-out or dot displacement in the test pattern.  
 Missing blocks indicate dot drop-out. Collapsed or inclined blocks indicate dot displacement.

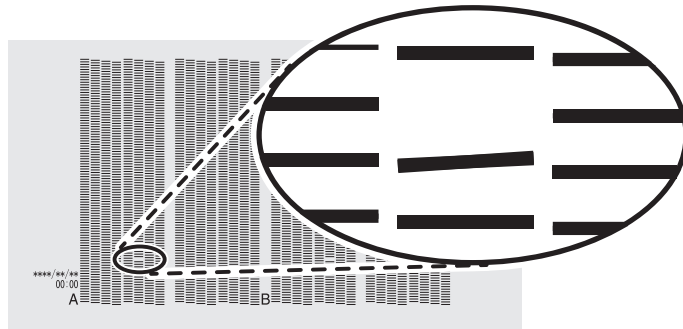

6. If you have opened the front cover, close it.  
 If no dot drop-out or dot displacement occurs, this operation is finished. Press [FUNCTION] to go back to the original screen.

If the dot drop-out or dot displacement location is different, perform medium cleaning another two or three times. If dot drop-out or dot displacement occurs in the same location on the test pattern, contact your authorized Roland DG Corporation dealer.

## Partially Restricting the Print Heads Used for Printing

When dot drop-out or dot displacement is not improved even if super cleaning is performed, partially restrict the print heads to use for printing (i.e. prevent the use of the print heads that are causing discharge issues). This operation is called the "nozzle mask," and while it slows down printing speed, it also allows you to decrease the impact of dot drop-out or dot displacement.

First print a test pattern, and then select the nozzle group to use by viewing the test results. After that, use VersaWorks to select the nozzle group used for printing.

### 1. Perform a printing test for the nozzle mask.

#### Procedure

1. Load the media.  
 Ⓞ P. 28 "Setup of Media"
2. Press [FUNCTION].
3. Press [▼] once, and then press [▶] twice to display the screen shown below.

```

TEST PRINT ◀
NOZZLE MASK ▶

```

4. Press [ENTER].  
 Printing of the test pattern starts.
5. Check for the nozzle group with dot drop-out or dot displacement by viewing the results of the printing test.

The results of the printing test are displayed separately for nozzle groups "1," "2," and "3." The following shows dot drop-outs in nozzle groups "1" and "3."

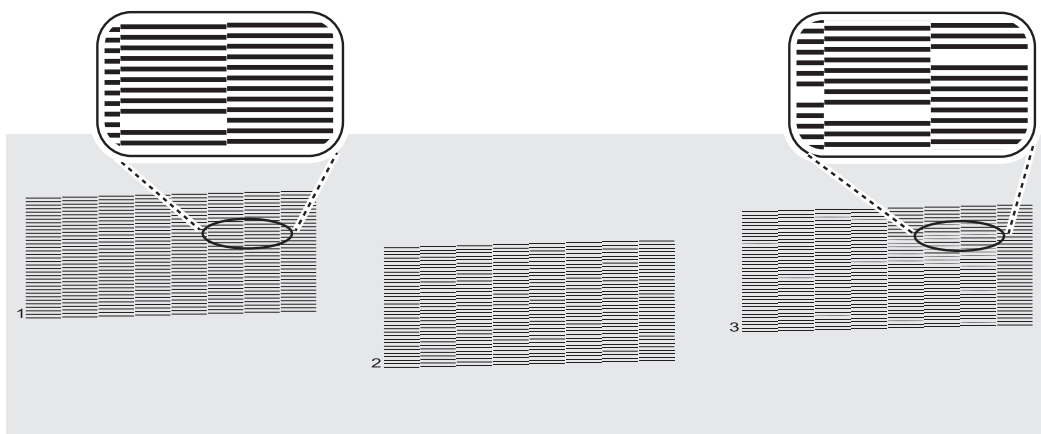

#### MEMO

**If the printing-test results are difficult to interpret**

Check the results in a bright location, changing your line of vision. They are visible using the reflection of the light.

## 2. Limit the print heads used for printing.

### Procedure

1. Start VersaWorks.
2. Click [Printer]>[Printer Settings].  
The [Printer Settings] dialog box appears.
3. From the [Printer List], select the printer whose print heads will be limited.
4. Click [Advanced].  
The [Advanced] dialog box appears.
5. Select the nozzle group to use in printing from the printing-test results.

The nozzle group numbers that can be selected vary depending on the model being used and the firmware version. Select the appropriate group number (or all the group numbers) to match the results of the printing test.

#### MEMO

If the firmware version is 1.2 or later, update VersaWorks to version 6.3.1 or later. For information on updating the software, contact your authorized Roland DG Corporation dealer or visit our website (<http://www.rolanddg.com/>).

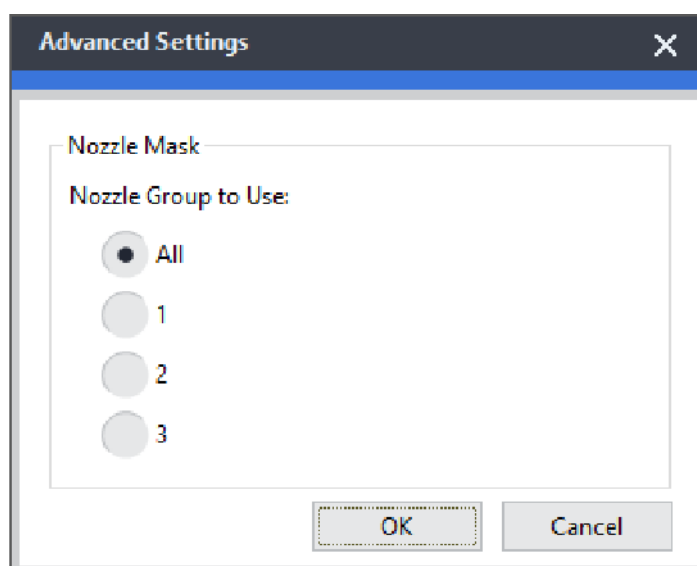

6. Click [OK].  
Close the [Advanced] dialog box.
7. Click [OK].  
Close the [Printer Settings] dialog box.

The  icon is displayed on top of the image of the printer whose setting has been changed.

#### RELATED LINKS

- VersaWorks manual

## Emergency Measure) Cleaning the Print Head Surface

When dot drop-out or dot deflection is not improved even if cleaning is performed several times, you can clean the surface of the print heads as an emergency measure. The print head surface (nozzle surface) is a very delicate mechanism, so work must be performed carefully and cautiously.

This operation is an emergency measure. It may damage defect-free parts depending on the symptoms, worsening the symptoms. If you have any questions, contact your authorized Roland DG Corporation dealer.

### Procedure

1. Apply a large amount of cleaning solution to the cleaning stick.
2. Very gently touch the cleaning stick against the print head surface (nozzle surface).

Very softly press the cleaning stick against the print head so that cleaning liquid soaks into the print head surface (nozzle surface). Never rub the stick on the surface or press it forcibly.

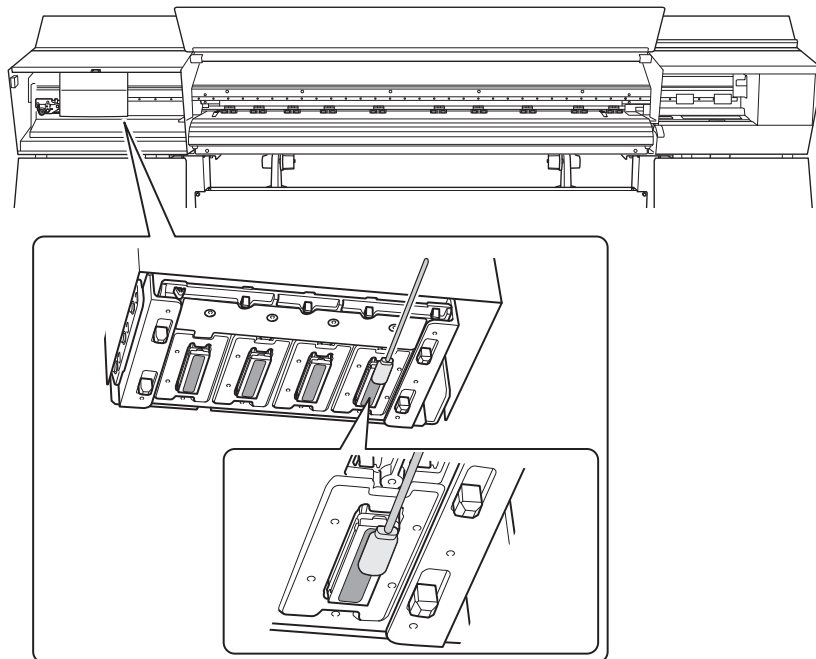

# Replacing Consumable Parts

---

|                                            |     |
|--------------------------------------------|-----|
| Replacing Parts for Maintenance .....      | 166 |
| Replacing the Wiper and the Tray Pad ..... | 166 |
| Cleaning the Wiper Tray.....               | 169 |
| Replacing the Separating Knife.....        | 171 |

# Replacing Parts for Maintenance

## Replacing the Wiper and the Tray Pad

The wipers and the tray pads are components that are used for cleaning the print heads.

When the following screen is displayed, it is time to replace the wiper.

```
TIME FOR
WIPER REPLACE↵
```

For information about purchasing wipers or tray pads, contact your authorized Roland DG Corporation dealer or visit our website (<http://www.rolanddg.com/>).

**⚠ CAUTION** Be sure to perform operations as specified by the instructions, and never touch any area not specified in the instructions. Otherwise sudden movement of the machine may cause injury.

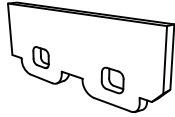
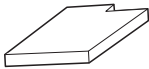
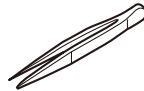
| Required items                                                                    |                                                                                   |                                                                                    |
|-----------------------------------------------------------------------------------|-----------------------------------------------------------------------------------|------------------------------------------------------------------------------------|
|  |  |  |
| Wiper                                                                             | Tray pad                                                                          | Tweezers                                                                           |

### Procedure

1. Press [ENTER] when the following screen appears.

```
TIME FOR
WIPER REPLACE↵
```

2. Remove any media.
3. Press [MENU].
4. Press [▼] several times to display the screen shown below.

```
MENU ◀◆
SUB MENU ▶
```

5. Press [▶] once, and then press [▼] several times to display the screen shown below.

```
SUB MENU ◀◆
MAINTENANCE ▶
```

6. Press [▶] to display the screen shown below.

```
MAINTENANCE ◀◆
REPLACE WIPER ↵
```

7. Press [ENTER].

The print-head carriage moves to a location where wiper replacement is possible, and then the screen shown below appears.

```
OPEN COVER R
```

8. Open the right cover.

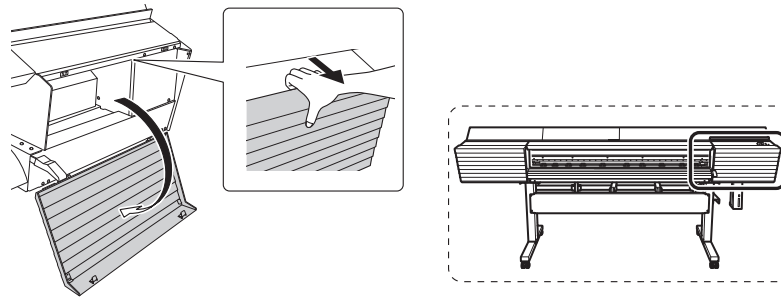

Preparation is complete once the following screen is displayed.



**IMPORTANT**

Do not press [ENTER] at this stage. Press [ENTER] after replacing the wipers and the tray pads. If you press [ENTER] at this stage, close the right cover according to the instructions on the screen, wait for the following screen to be displayed, and then press [ENTER] again.



**9.** Touch the location shown in the figure to discharge any static electricity.

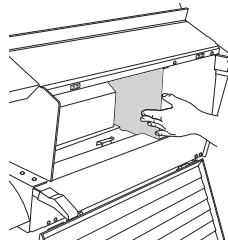

**10.** Replace the wipers.

(1) Detach the old wipers.

Using the tweezers, unhook the wipers, and then pull them up. Using the tweezers to press on the hook in the hole on the wiper makes it easier to remove the wiper.

(2) Attach the new wipers.

Place the inclined end of the wiper on the back side of the machine. If the wiper is installed with the incorrect orientation, appropriate cleaning will not be possible.

Be sure to attach the wipers to the hooks. Failure to do so may result in dot drop-out or other problems.

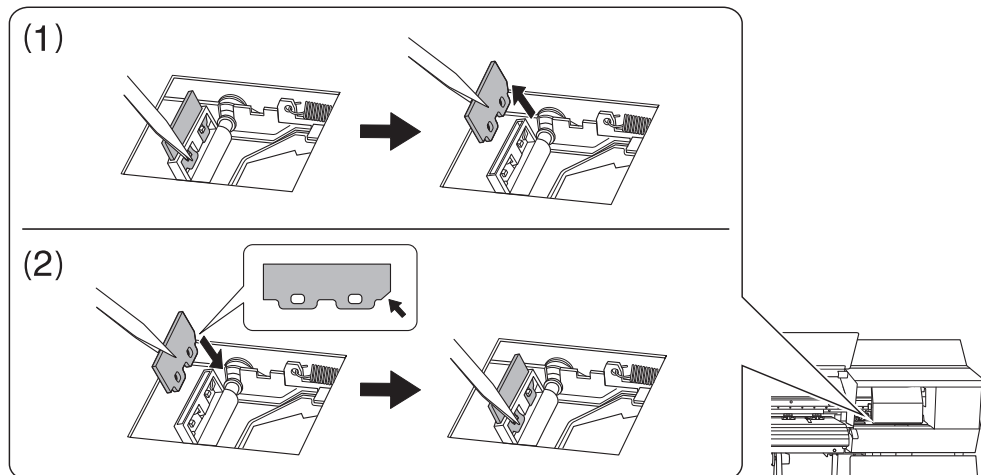



**11.** Replace the tray pad.

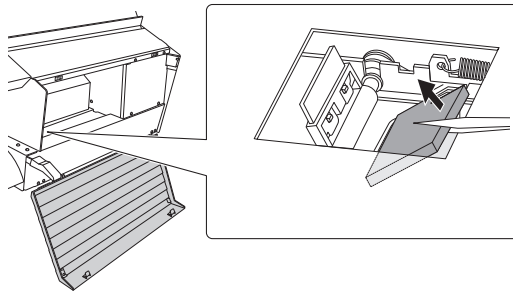

**IMPORTANT**

Place the tray pad with an orientation that matches the shape of the wiper tray. If you place the tray pad with the incorrect orientation, it will not be possible to clean the wiper correctly.

**12.** Press [ENTER].

**13.** When the following screen is displayed, close the right cover.



When the following screen is displayed again, the wiper replacement is finished.



**14.** Press [MENU] to go back to the original screen.

## Cleaning the Wiper Tray

Discharged fluid collects in the wiper tray. The wiper tray must be cleaned periodically. If the following message is displayed, clean the wiper tray.

```
TIME FOR
TRAY CLEANING↵
```

- ⚠ CAUTION** Be sure to perform operations as specified by the instructions, and never touch any area not specified in the instructions. Otherwise sudden movement of the machine may cause injury.

### Procedure

1. Press [ENTER].

```
TIME FOR
TRAY CLEANING↵
```

2. Press [MENU].

3. Press [▼] several times to display the screen shown below.

```
MENU ◀◆
SUB MENU ▶
```

4. Press [▶] once, and then press [▼] several times to display the screen shown below.

```
SUB MENU ◀◆
MAINTENANCE ▶
```

5. Press [▶] once, and then press [▼] several times to display the screen shown below.

```
MAINTENANCE ◀◆
TRAY CLEANING ↵
```

6. Press [ENTER].

The screen shown below appears.

```
EMPTY
DRAIN BOTTLE↵
```

7. Remove the drain bottle and discard the discharged fluid.



### IMPORTANT

When you remove the drain bottle, a few drops of discharged fluid may come out of the machine. Exercise caution to prevent this fluid from soiling your hands or the floor.

- ⚠ CAUTION** Before you detach the drain bottle, be sure to wait for the screen to display "EMPTY DRAIN BOTTLE". After discarding the discharged fluid, promptly attach the drain bottle to the machine. Failing to follow this procedure may cause discharged fluid to flow out of the tube and spill, soiling your hands or the floor.
- ⚠ WARNING** Never place discharged fluid or ink near an open flame. Doing so may cause a fire.
- ⚠ CAUTION** To store discharged fluid temporarily, place it in the included drain bottle or in a durable sealed container such as a metal can or polyethylene tank, and cap tightly.

Any spillage or vapor leakage may cause fire, odor, or physical distress.

**IMPORTANT**

Do not store discharged fluid in a location where it is exposed to direct sunlight. When temporarily storing discharged fluid in the included drain bottle, do not store it in a location that is exposed to direct sunlight. The discharged fluid may harden, making the drain bottle unusable. The drain bottle may also deteriorate, leading to discharged fluid leaks.

**IMPORTANT**

Dispose of discharged fluid properly, in accordance with the laws in effect in your locale. Discharged fluid is flammable and contains toxic ingredients. Never attempt to incinerate discharged fluid or discard it with ordinary trash. Also, do not dispose of it in sewer systems, rivers, or streams. Doing so may have an adverse impact on the environment.

**8.** Quickly attach the emptied drain bottle to the machine once more.

**9.** Press [ENTER].

After the "DRAIN TRAY" screen appears, the screen shown below appears, and then the machine is filled with TR2 cleaning liquid. The (approximate) remaining time for the procedure is displayed on the screen. (The display shown below is an example. "01:40" = "1 minute and 40 seconds")

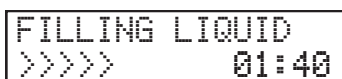

If the TR2 cleaning liquid runs out during filling, the screen shown below appears. Replace the TR2 cleaning liquid pouch. When you replace the wiper cleaning liquid pouch, the display returns to the original screen.

➤ P. 50 "TR2 Cleaning Liquid Pouch Replacement"



When the following screen is displayed again, the wiper tray cleaning is finished.



**10.** Press [MENU] to go back to the original screen.

# Replacing the Separating Knife

If the separating knife becomes dull, replace it with the included replacement knife.

**⚠ CAUTION** Be sure to perform operations as specified by the instructions, and never touch any area not specified in the instructions. Otherwise sudden movement of the machine may cause injury.

**⚠ CAUTION** Do not touch the tip of the separating knife. Doing so may result in injury.

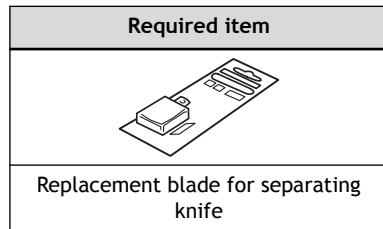

## Procedure

1. Remove any media.
2. Press [MENU].
3. Press [▼] several times to display the screen shown below.



4. Press [▶] once, and then press [▼] several times to display the screen shown below.

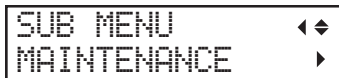

5. Press [▶] once, and then press [▼] several times to display the screen shown below.



6. Press [ENTER].  
The separating knife moves to a position where replacement is possible.
7. When the following screen is displayed, open the front cover.



Preparation is complete once the following screen is displayed.

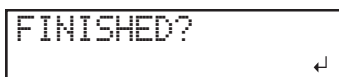

8. Remove the separating knife.
  - (1) Loosen the screw until it slips out.
  - (2) Grasp the screw portion, and slowly pull in the direction of the arrow.  
When doing this, do not pull it back toward you.

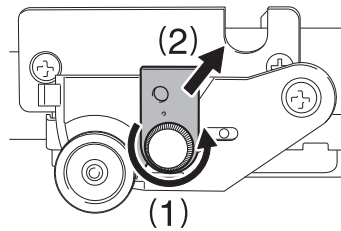

**9. Install a new knife.**

Slide the knife to align it with the groove (①). The knife is secured in place by the magnet(②).

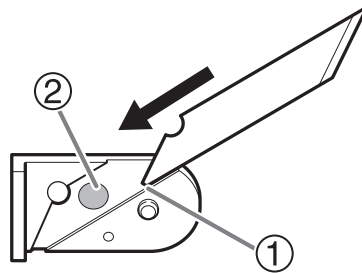

**10. Slowly insert the knife into the groove.**

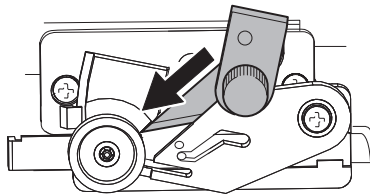

**11. Tighten the screw.**

Take care to ensure that the knife does not slip out of position at this time.

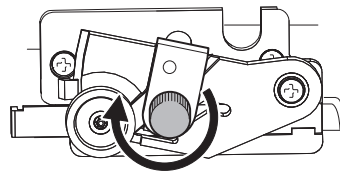

**12. Close the front cover.**

**13. Press [ENTER].**

When the following screen is displayed again, the blade replacement is finished.



**14. Press [MENU] to go back to the original screen.**

# Troubleshooting Methods

# Output Quality Problems

---

|                                                                                    |     |
|------------------------------------------------------------------------------------|-----|
| Printed results are coarse or contain horizontal stripes.....                      | 175 |
| Do the print heads cause dot drop-out? .....                                       | 175 |
| Is the print head height appropriate? .....                                        | 175 |
| Have you carried out feed correction (calibration)?.....                           | 175 |
| Have you carried out correction of the ink landing position (MEDIA GAP ADJ.)?..... | 175 |
| Is the printer installed in a level and stable location? .....                     | 175 |
| Is the media heating system at a suitable temperature? .....                       | 175 |
| Is the temperature of the room too low?.....                                       | 176 |
| Is the print mode suitable? .....                                                  | 176 |
| Is the media loaded correctly? .....                                               | 176 |
| Are the settings for the "PRESET" menu item appropriate?.....                      | 176 |
| The media becomes soiled when printed .....                                        | 177 |
| Do the print heads come into contact with the media?.....                          | 177 |
| Are the print heads dirty?.....                                                    | 177 |
| Are the pinch rollers or the media clamps dirty? .....                             | 177 |
| Colors are unstable or uneven.....                                                 | 178 |
| Have you tried mixing the ink by shaking the pouch trays? .....                    | 178 |
| Are colors still uneven after mixing the ink by shaking the pouch trays? .....     | 178 |
| Is the media wrinkled? .....                                                       | 178 |
| Was printing paused partway through? .....                                         | 178 |
| Is the printer installed in a level and stable location? .....                     | 178 |
| Is the media loaded correctly? .....                                               | 178 |
| Are the operating parameters set to appropriate values? .....                      | 179 |
| Are the settings for the "PRESET" menu item appropriate?.....                      | 179 |

# Printed results are coarse or contain horizontal stripes

## Do the print heads cause dot drop-out?

Carry out a printing test and make sure no dot drop-out or dot displacement occurs. If dot drop-out or dot displacement is present, perform head cleaning.

### RELATED LINKS

---

- P. 54 "Printing Tests and Normal Cleaning"
  - P. 140 "When Normal Cleaning Is Not Effective"
- 

## Is the print head height appropriate?

Printing when the "HEAD HEIGHT" menu item is set to "HIGH" or to "MID" is coarser than when set to "LOW". Keep this set to "LOW" except when changing it is necessary, such as when you are using thick media.

### RELATED LINKS

---

- P. 77 "Changing the Print Head Height"
- 

## Have you carried out feed correction (calibration)?

Large misalignment in the amount of feed of the media may result in printing that seems coarse or contains horizontal stripes. Either make the setting in the software RIP to match the type of media you are using, or make the setting for correction on the printer.

### RELATED LINKS

---

- P. 75 "Reducing Horizontal Bands (Feed Correction Function)"
- 

## Have you carried out correction of the ink landing position (MEDIA GAP ADJ.)?

The optimal adjustment value varies depending on the thickness of the media. Set an adjustment value that is suitable for the media. When further correction is required, such as when adjustment made using "SIMPLE SETTING" does not enhance printing, use "DETAIL SETTING" to make the correction.

### RELATED LINKS

---

- P. 70 "Adjusting the Misalignment of the Ink Landing Position"
  - P. 72 "Accurately Adjusting the Misalignment of the Ink Landing Position"
- 

## Is the printer installed in a level and stable location?

Never install the machine in a location where it is tilted or where it may wobble or experience vibration. Also make sure that the print heads are not exposed to moving air. These factors may lead to dot drop-out or reduced printing quality.

## Is the media heating system at a suitable temperature?

If the ink forms lumps or smudges, raise the temperature. Note, however, that a temperature that is too high may degrade the media or cause it to wrinkle.

### RELATED LINKS

---

- P. 87 "Setting the Print Heater Temperature"



- P. 88 "Setting the Dryer Temperature"
- 

### Is the temperature of the room too low?

The media heating system may not warm up sufficiently when the ambient temperature is less than 20°C (68°F). Also, even when the media heating system reaches its set temperatures, adequate effectiveness may not be apparent if the media is thoroughly chilled. Before printing, allow the media to come to room temperature.

### Is the print mode suitable?

If attractive printing is impossible even when the media heating system is at a high temperature, try using a higher-quality print mode. Depending on the media, smudging may occur when using a high-quality print mode, and results may also vary greatly depending on the settings of your software RIP (such as the color-profile selection). Select settings appropriate for the media you are using.

### Is the media loaded correctly?

If the media is not loaded correctly or the media feed is not smooth, printing may be adversely affected. Load the media correctly.

#### RELATED LINKS

---

- P. 28 "Setup of Roll Media"
  - P. 35 "Setup of Sheet Media"
- 

### Are the settings for the "PRESET" menu item appropriate?

If the settings selected with the "PRESET" menu item are not suitable for the type of media, printing may be adversely affected. Choose settings optimized for the media you are using.

#### RELATED LINKS

---

- P. 97 "Using Presets"
-

# The media becomes soiled when printed

---

## Do the print heads come into contact with the media?

The height of the print heads may be too low. Also, if the media is not loaded and set up correctly, it may wrinkle or come loose and contact the print heads.

### RELATED LINKS

---

- P. 28 "Setup of Roll Media"
  - P. 35 "Setup of Sheet Media"
  - P. 77 "Changing the Print Head Height"
- 

## Are the print heads dirty?

The following may cause ink to drip on the media during printing.

- Buildup of fibrous dust (lint) around the heads
- Ink transferred to the heads due to rubbing against the media

If this happens, clean the print heads manually. We recommend carrying out periodic head cleaning.

- Too low humidity

Use the machine in an environment with a humidity of 35 to 80%RH (no condensation).

### RELATED LINKS

---

- P. 144 "Manual Cleaning"
- 

## Are the pinch rollers or the media clamps dirty?

Periodically clean them.

### RELATED LINKS

---

- P. 132 "Cleaning the Machine"
-

# Colors are unstable or uneven

## Have you tried mixing the ink by shaking the pouch trays?

If colors are uneven, remove the pouch trays, and then shake them 50 times (for approximately 20 seconds).

### RELATED LINKS

---

- P. 152 "Mixing the Ink by Shaking the Pouch Tray"
- 

## Are colors still uneven after mixing the ink by shaking the pouch trays?

If uneven color issues with white ink are not resolved even after shaking the pouch trays to mix the ink, perform "damper cleaning."

If uneven color issues with ink other than white ink (C, M, Y, K, Lc, Lm, Lk, Or, or Gr ink) are not resolved even after shaking the pouch trays to mix the ink, perform super cleaning.

### RELATED LINKS

---

- P. 154 "Damper Cleaning Method"
  - P. 157 "Super Cleaning Method"
- 

## Is the media wrinkled?

If the media is wrinkled and comes loose from the platen, colors may be uneven or the printing quality may suffer.

### RELATED LINKS

---

- P. 28 "Setup of Roll Media"
  - P. 35 "Setup of Sheet Media"
- 

## Was printing paused partway through?

When printing is paused, the coloring at the seam may be altered when printing resumes. Avoid pausing printing. Before you perform lengthy printing, check the amount of ink remaining in the ink pouches. Printing may also pause when data is not sent from the computer quickly enough. We recommend not performing any other tasks with the computer while printing is in progress.

## Is the printer installed in a level and stable location?

Never install the machine in a location where it is tilted or where it may wobble or experience vibration. Also make sure that the print heads are not exposed to moving air. These factors may lead to dot drop-out or reduced printing quality.

## Is the media loaded correctly?

If the media is not loaded correctly or the media feed is not smooth, printing may be adversely affected. Load the media correctly.

### RELATED LINKS

---

- P. 28 "Setup of Roll Media"
  - P. 35 "Setup of Sheet Media"
-

---

### Are the operating parameters set to appropriate values?

Depending on the settings for such menu items as "FULL WIDTH S" and "PERIODIC CL.", uneven colors may occur. If the settings have been changed, try restoring them to their default values.

#### RELATED LINKS

---

- P. 102 "Speeding Up Output for Narrow Media"
  - P. 85 "Preventing Soiling of the Media, Dot Drop-out, and Dot Displacement"
- 

### Are the settings for the "PRESET" menu item appropriate?

If the settings selected with the "PRESET" menu item are not suitable for the type of media, printing may be adversely affected. Choose settings optimized for the media you are using.

#### RELATED LINKS

---

- P. 97 "Using Presets"
-

# Media Feed Problems

---

|                                                                |     |
|----------------------------------------------------------------|-----|
| Media Wrinkles or Shrinks .....                                | 181 |
| Is the media loaded and set up straight and securely? .....    | 181 |
| Was loaded media allowed to stand for some time? .....         | 181 |
| Are the media clamps attached? .....                           | 181 |
| Was the media loaded while the print heater was hot? .....     | 181 |
| Are the media heating system temperatures too high? .....      | 181 |
| Is the temperature of the room too low? .....                  | 181 |
| Is the humidity of the room too high? .....                    | 181 |
| Is the media sagging? .....                                    | 181 |
| Media Feeding Is Not Straight .....                            | 182 |
| Is the media loaded and set up straight and securely? .....    | 182 |
| Media Feeding Is Not Smooth .....                              | 183 |
| Is some other object coming into contact with the media? ..... | 183 |
| Is the media too thick? .....                                  | 183 |
| Are the grit rollers dirty? .....                              | 183 |
| A Media Jam Occurs! .....                                      | 184 |
| Is an error message displayed? .....                           | 184 |
| Is the media warped or wrinkled? .....                         | 184 |
| Is the height of the print heads too low? .....                | 184 |
| Are the grit rollers dirty? .....                              | 184 |
| Are the media clamps attached? .....                           | 184 |
| Is the media loaded and set up straight and securely? .....    | 184 |
| Is some other object coming into contact with the media? ..... | 184 |
| Is the media too thick? .....                                  | 185 |

# Media Wrinkles or Shrinks

## Is the media loaded and set up straight and securely?

Feeding is not smooth when the media is not straight or is tensioned unevenly on the left and right. Reload the media.

### RELATED LINKS

- P. 28 "Setup of Roll Media"
- P. 35 "Setup of Sheet Media"

## Was loaded media allowed to stand for some time?

Media may shrink or wrinkle if it is heated for an extended time. When printing ends, switch off the sub power and remove the media.

## Are the media clamps attached?

When you are performing printing, be sure to attach the media clamps.

## Was the media loaded while the print heater was hot?

Loading media after the print heater has warmed up causes the temperature of the media to rise suddenly, which may cause the media to shrink or wrinkle during printing. Before loading media, switch off the sub power and allow the platen to cool.

### RELATED LINKS

- P. 86 "Adjusting the Ink-drying Method"

## Are the media heating system temperatures too high?

Set the temperatures to suitable values for the type of media.

### RELATED LINKS

- P. 86 "Adjusting the Ink-drying Method"

## Is the temperature of the room too low?

The media heating system may not warm up sufficiently when the ambient temperature is less than 20°C (68°F). Also, even when the media heating system reaches its set temperatures, adequate effectiveness may not be apparent if the media is thoroughly chilled. Before printing, allow the media to come to room temperature.

## Is the humidity of the room too high?

Use the machine in an environment with a humidity of 35 to 80%RH (no condensation).

High humidity can cause the media to sag. If sagging media is used, it may come out wrinkled.

## Is the media sagging?

If sagging media is used, it may come out wrinkled.

# Media Feeding Is Not Straight

---

## Is the media loaded and set up straight and securely?

Feeding is not smooth when the media is not straight or is tensioned unevenly on the left and right. Reload the media.

### RELATED LINKS

---

- P. 28 "Setup of Roll Media"
  - P. 35 "Setup of Sheet Media"
-

# Media Feeding Is Not Smooth

---

## Is some other object coming into contact with the media?

Make sure the media does not touch anything else. This may affect output, even when the feed appears to be smooth.

### RELATED LINKS

---

- P. 28 "Setup of Roll Media"
  - P. 35 "Setup of Sheet Media"
- 

## Is the media too thick?

Media that is too thick may not only cause an unstable feed but may scrape the print heads, resulting in a malfunction. Never use such media.

## Are the grit rollers dirty?

Check to make sure the grit rollers are free of buildup of foreign material such as media scraps.

### RELATED LINKS

---

- P. 132 "Cleaning the Machine"
-



# A Media Jam Occurs!

## Is an error message displayed?

If an error message is displayed because the media has jammed, immediately correct the problem. Doing so may damage the print heads.

### RELATED LINKS

- P. 199 "MOTOR ERROR TURN POWER OFF"

## Is the media warped or wrinkled?

Many factors can cause warping or wrinkling. Refer to the following and correct the problem.

### RELATED LINKS

- P. 181 "Media Wrinkles or Shrinks"

## Is the height of the print heads too low?

Try raising the print heads higher. First, try setting the height to "MID", and if the media is still jammed, change it to "HIGH". Media may inevitably warp or wrinkle slightly, so adjust the height of the print heads to take this into account.

### RELATED LINKS

- P. 77 "Changing the Print Head Height"

## Are the grit rollers dirty?

Check to make sure the grit rollers are free of buildup of foreign material such as media scraps.

### RELATED LINKS

- P. 132 "Cleaning the Machine"

## Are the media clamps attached?

When you are performing printing, be sure to attach the media clamps.

## Is the media loaded and set up straight and securely?

Feeding is not smooth when the media is not straight or is tensioned unevenly on the left and right. Reload the media.

### RELATED LINKS

- P. 28 "Setup of Roll Media"
- P. 35 "Setup of Sheet Media"

## Is some other object coming into contact with the media?

Make sure the media does not touch anything else. This may affect output, even when the feed appears to be smooth.

### RELATED LINKS

- P. 28 "Setup of Roll Media"

- 
- P. 35 "Setup of Sheet Media"
- 

### Is the media too thick?

Media that is too thick may not only cause an unstable feed but may scrape the print heads, resulting in a malfunction. Never use such media.

# Machine Problems

---

|                                                                                                                             |     |
|-----------------------------------------------------------------------------------------------------------------------------|-----|
| The Print Heads Do Not Move .....                                                                                           | 187 |
| What to Do First .....                                                                                                      | 187 |
| If the Print Heads Still Do Not Move .....                                                                                  | 187 |
| The printer unit does not run.....                                                                                          | 188 |
| Is the power switched on? .....                                                                                             | 188 |
| Is [SETUP] lit? .....                                                                                                       | 188 |
| Are any covers open? .....                                                                                                  | 188 |
| Is the top menu displayed? .....                                                                                            | 188 |
| Is [PAUSE] lit? .....                                                                                                       | 188 |
| Is a message displayed on the screen? .....                                                                                 | 188 |
| Are the cables connected? .....                                                                                             | 188 |
| Is the LAN routing appropriate? .....                                                                                       | 189 |
| Are the LAN settings correct? .....                                                                                         | 189 |
| Did the software RIP end abnormally? .....                                                                                  | 189 |
| Has the ink run out? .....                                                                                                  | 189 |
| The Media Heating System Doesn't Warm Up.....                                                                               | 190 |
| Is the media loaded? .....                                                                                                  | 190 |
| Is HEATER CONFIG set to OFF?.....                                                                                           | 190 |
| Is the temperature of the room too low?.....                                                                                | 190 |
| Cannot Separate the Media .....                                                                                             | 191 |
| Is the separating knife installed? .....                                                                                    | 191 |
| Is the cut rail installed? .....                                                                                            | 191 |
| Printer Cannot Be Operated from the Operation Application .....                                                             | 192 |
| Is the printer's operation panel in use? .....                                                                              | 192 |
| Is printer-side Bluetooth communication turned on? .....                                                                    | 192 |
| Is the operation application connected to a different printer? .....                                                        | 192 |
| Is the printer-side Bluetooth communication normal? .....                                                                   | 192 |
| Is the distance between the printer and the mobile terminal too far? .....                                                  | 192 |
| Are there any obstacles between the printer and the mobile terminal? .....                                                  | 193 |
| Is the mobile terminal's Bluetooth function turned on? .....                                                                | 193 |
| Is there a wireless LAN unit or anything else in the vicinity that is causing Bluetooth communication to be unstable? ..... | 193 |

# The Print Heads Do Not Move

If the print-head carriage stops over the platen, take action immediately to prevent the heads from drying out.

## What to Do First

Switch the sub power off and then back on again. If the media is jammed, also remove the media. If the print heads move to the home position (inside the right cover), it means the operation has ended successfully.

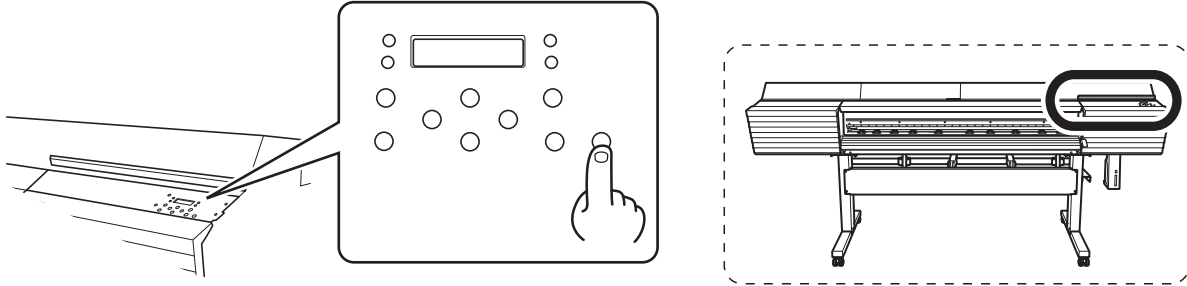

## If the Print Heads Still Do Not Move

Try switching off the main power, then switching on the main power again, followed by the sub power.

## If the Print Heads Still Do Not Move

If the heads still do not move, carry out the following emergency response measure, and then contact your authorized Roland DG Corporation dealer.

### Procedure

1. Switch off the main power, and then open the front cover.
2. Open the right cover.

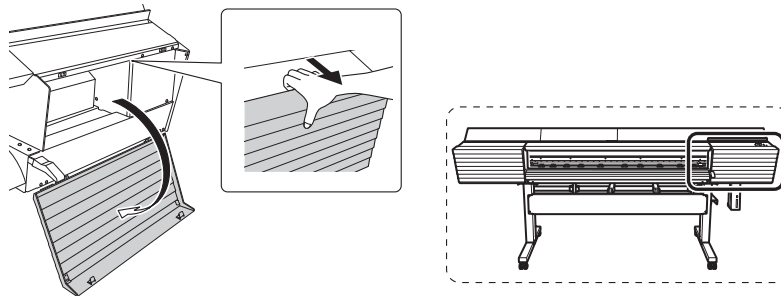

3. Gently move the print-head carriage to the home position by hand.  
Stopping at the place where the audible click is heard locks the print-head carriage in place.

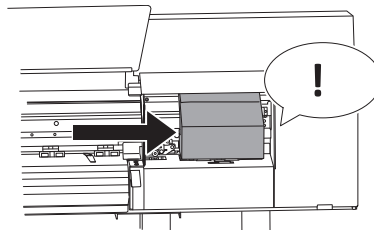

4. Gently apply pressure from the right side to make sure the print-head carriage does not move to the left.  
If the print-head carriage moves to the left, move it again slowly by applying pressure from the left side and make sure it locks in place.

# The printer unit does not run

## Is the power switched on?

Switch on the printer's main power, and then press the sub power switch and make sure the sub power switch lights.

### RELATED LINKS

- P. 24 "Turning the Power On"

## Is [SETUP] lit?

Output is not performed when [SETUP] is not lit. After loading the media, lower the loading lever, and then press [ENTER].

### RELATED LINKS

- P. 66 "Starting Output"

## Are any covers open?

Close the front, left, and right covers.

## Is the top menu displayed?

Top menu

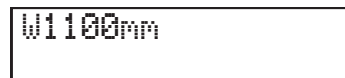

If the top menu isn't displayed, output doesn't start even when data is sent from the computer. To go to the top menu, press [MENU].

### RELATED LINKS

- P. 66 "Starting Output"

## Is [PAUSE] lit?

When [PAUSE] is lit, operation is paused. To resume, press [PAUSE]. [PAUSE] turns off and output resumes.

### RELATED LINKS

- P. 44 "Pausing and Canceling Output"

## Is a message displayed on the screen?

### RELATED LINKS

- P. 195 "Messages"
- P. 198 "Error Messages"

## Are the cables connected?

Connect the cables securely.

---

**RELATED LINKS**

---

- VF2-640 Setup Guide
- 

**Is the LAN routing appropriate?**

Check whether or not the network routing is appropriate. Try connecting the computer and the machine to the same hub or connecting them directly using a cable. If this makes it possible to perform output, it means the problem may be in the network itself.

**Are the LAN settings correct?**

If the cable connections are secure and no problem is found in the network itself, make sure that the IP address and other such settings are appropriate. The settings on both the machine and the computer must be appropriate. Redo the settings, checking to ensure that the IP address does not conflict with the IP address for another device on the network, that the port setting for the software RIP specifies the IP address set on the machine, that the settings have no typing errors, and for other such problems.

---

**RELATED LINKS**

---

- P. 123 "Viewing System Information"
  - VF2-640 Setup Guide
- 

**Did the software RIP end abnormally?**

Make sure the software RIP is running correctly, and then switch the sub power switch off and back on.

---

**RELATED LINKS**

---

- VersaWorks manual
- 

**Has the ink run out?**

When the screen shown in the figure is displayed, output data cannot be accepted. The error can be resolved by replacing the ink pouch with a new one. If there is data that has not yet been output remaining in the machine, output resumes. If there is unsent data in the computer, output resumes when the data is resent.

---

**RELATED LINKS**

---

- P. 48 "Ink Pouch Replacement"
-

# The Media Heating System Doesn't Warm Up

---

## Is the media loaded?

The media heating system does not warm up to the set temperature when [SETUP] is off (by default). Load the media and wait for the machine to warm up.

### RELATED LINKS

---

- P. 86 "Adjusting the Ink-drying Method"
- 

## Is HEATER CONFIG set to OFF?

Even if you set the print heater temperature in the batch settings for printing (the MEDIA SETTING menu), if "POWER" under HEATER CONFIG is set to "OFF", the media heating system will not warm up. Set "POWER" under HEATER CONFIG to "ON".

### RELATED LINKS

---

- P. 93 "Switching Off the Print Heater and Dryer Together"
- 

## Is the temperature of the room too low?

The media heating system may not warm up sufficiently when the ambient temperature is less than 20°C (68°F). Also, even when the media heating system reaches its set temperatures, adequate effectiveness may not be apparent if the media is thoroughly chilled. Before printing, allow the media to come to room temperature.

# Cannot Separate the Media

## Is the separating knife installed?

If the separating knife is not installed, you cannot separate the media.

### RELATED LINKS

- P. 171 "Replacing the Separating Knife"

## Is the cut rail installed?

If the cut rail is not installed, you cannot separate the media. If the cut rail is not installed, open the left cover, and then install the cut rail according to the figure shown below. After installing the cut rail, be sure to close the left cover.

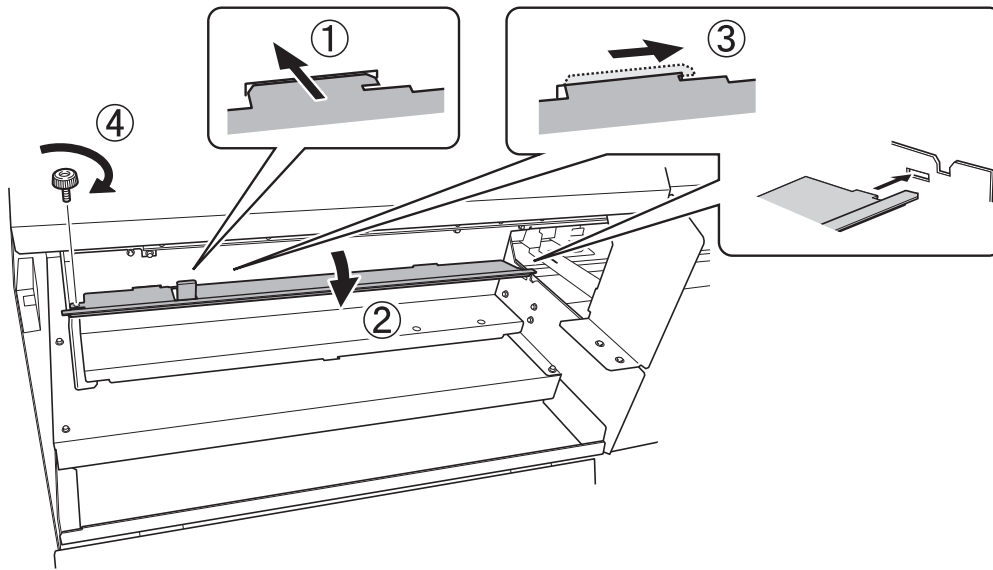



# Printer Cannot Be Operated from the Operation Application

---

## RELATED LINKS

- P. 108 "Important Notes on Using the Operation Application"
- 

### Is the printer's operation panel in use?

When you are using the printer's operation panel, you cannot perform operations from the dedicated mobile operation application (hereinafter referred to as the "operation application"). Stop performing operations from the operation panel. When using the [MENU] or [FUNCTION] menu from the operation panel, press [MENU] or [FUNCTION] to display "SETUP SHEET" or the media width, "W\*\*\*\*mm", on the machine operating screen.

---

## RELATED LINKS

- P. 107 "Using the Operation Application"
- 

### Is printer-side Bluetooth communication turned on?

The printer's Bluetooth communication is turned off in the default settings. When using the operation application, use the printer's operation panel to turn on Bluetooth communication.

---

## RELATED LINKS

- P. 121 "Turning on Bluetooth Communication"
- 

### Is the operation application connected to a different printer?

You can only connect to one printer from a mobile terminal on which the operation application has been installed. If multiple printers have been registered, use the operation application to select the printer that you will connect to.

### Is the printer-side Bluetooth communication normal?

The state of the printer's Bluetooth communication is displayed on the screen.

- "ENABLE": The printer's Bluetooth communication is on, and the printer is waiting for a connection to be established. If you cannot operate this machine from the operation application that you are using, there is a problem with the connection environment. Check the causes of other problems.
- "ENABLE"\* The printer's Bluetooth communication is on, and the printer is connected to the operation application.
- "DISABLE": The printer's Bluetooth communication is off.
- "ERROR": An error has occurred in the printer's Bluetooth communication. Purchase them from your authorized Roland DG Corporation dealer.

However, when the above screen is displayed, you cannot perform operations from the operation application.

---

## RELATED LINKS

- P. 107 "Using the Operation Application"
  - P. 123 "Viewing System Information"
- 

### Is the distance between the printer and the mobile terminal too far?

The valid range for Bluetooth communication is approximately 10 m. Bring the printer and the mobile terminal on which the operation application has been installed as close together as possible.

### **Are there any obstacles between the printer and the mobile terminal?**

If obstacles (such as people, metal, and walls) are present between the printer and the mobile terminal, Bluetooth communication may be unstable. Use the operation application from a location where there are no obstacles between the printer and the mobile terminal.

### **Is the mobile terminal's Bluetooth function turned on?**

Check the Bluetooth status of the mobile terminal. For the usage method of your mobile terminal, refer to its user's manual.

### **Is there a wireless LAN unit or anything else in the vicinity that is causing Bluetooth communication to be unstable?**

The Bluetooth communication status may become unstable if:

- A wireless LAN is in place in the location.
- The devices are in the vicinity of a microwave that is in use.
- Other electromagnetic waves are generated in the location.

# Messages on the Operation Panel

---

|                                         |     |
|-----------------------------------------|-----|
| Messages .....                          | 195 |
| 1 ■ 2 ■ 3 ■ 4 ■ 5 ■ 6 ■ 7 ■ 8 ■ .....   | 195 |
| "CLOSE THE COVER" .....                 | 195 |
| "SHEET NOT LOADED SETUP SHEET" .....    | 195 |
| "CLOSE SLOT COVER" .....                | 195 |
| "END OF THE SHEET" .....                | 195 |
| "EMPTY DRAIN BOTTLE" .....              | 195 |
| "INSTALL DRAIN BOTTLE" .....            | 195 |
| "NOW HEATING..." .....                  | 195 |
| "TIME FOR MAINTENANCE" .....            | 196 |
| "TIME FOR WIPER REPLACE" .....          | 196 |
| "SET CL-LIQUID FOR WIPER" .....         | 196 |
| "CHANGE CL-LIQUID FOR WIPER" .....      | 196 |
| "TIME FOR TRAY CLEANING" .....          | 196 |
| "HEAD PROTECTION ACTIVATED" .....       | 196 |
| "SHAKE ALL INK POUCH TRAY" .....        | 196 |
| Error Messages .....                    | 198 |
| "OPTION DRYER IS NOT CONNECTED" .....   | 198 |
| "TEMPERATURE IS TOO LOW **° C" .....    | 198 |
| "TEMPERATURE IS TOO HIGH **° C" .....   | 198 |
| "CAN'T PRINT CROP CONTINUE?" .....      | 198 |
| "SHEET TOO SMALL CONTINUE?" .....       | 198 |
| "DATA ERROR CANCELING..." .....         | 198 |
| "SHEET SET ERROR SET AGAIN" .....       | 199 |
| "PINCHROLL ERROR LOWER PINCHROLL" ..... | 199 |
| "WRONG CARTRIDGE 12345678" .....        | 199 |
| "CANCELED FOR PUMP PROTECTION" .....    | 199 |
| "AVOIDING DRY-UP TURN POWER OFF" .....  | 199 |
| "SET HEAD HEIGHT TO ****" .....         | 199 |
| "MOTOR ERROR TURN POWER OFF" .....      | 199 |
| "SERVICE CALL ****" .....               | 200 |
| "CLEANING ERROR" .....                  | 200 |

# Messages

These are the main messages that appear on the machine's display to prompt correct operation. They do not indicate any error. Follow the prompts and take action accordingly.

1 ■ 2 ■ 3 ■ 4 ■ 5 ■ 6 ■ 7 ■ 8 ■

Only a small amount of ink remains.

Replace the ink pouch indicated by the flashing number with a new pouch.

## "CLOSE THE COVER"

The front, left, or right cover is open. For safety, some carriage operations are limited while a cover is open.

Close the front, left, or right cover.

## "SHEET NOT LOADED SETUP SHEET"

This message appears when an attempt to perform a printing test was made while no media was loaded.

Load media.

## "CLOSE SLOT COVER"

This message appears if the ink slot cover is open when output starts.

Close the ink slot cover.

## "END OF THE SHEET"

The trailing edge of the media was detected during operation.

Press any key on the operation panel to clear the message. Load new media.

## "EMPTY DRAIN BOTTLE"

This message appears when a certain amount of discharged fluid collects in the drain bottle.

Discard the discharged fluid in the bottle.

### RELATED LINKS

---

- P. 135 "If the Discharged Fluid Disposal Message Appears"
- 

## "INSTALL DRAIN BOTTLE"

Check whether the drain bottle is installed correctly.

Install the drain bottle, and then press [ENTER].

### RELATED LINKS

---

- P. 134 "Disposing of Discharged Fluid"
- 

## "NOW HEATING..."

The media heating system did not reach the set temperature.

Wait until the set temperature is reached. Printing starts when [HEATER] lights. You can stop printing by holding down [PAUSE] for 1 second or longer while this is displayed. Pressing [PAUSE] makes printing start immediately without waiting to reach the preset temperature.

---

### "TIME FOR MAINTENANCE"

It is time to perform manual cleaning.

After verifying the message, press [ENTER], and then perform manual cleaning.

---

#### RELATED LINKS

- P. 144 "Manual Cleaning"
- 

### "TIME FOR WIPER REPLACE"

It is time to replace the wipers.

After verifying the message, press [ENTER], and then replace the wiper.

---

#### RELATED LINKS

- P. 166 "Replacing the Wiper and the Tray Pad"
- 

### "SET CL-LIQUID FOR WIPER"

No TR2 cleaning liquid pouch has been inserted.

Quickly insert a TR2 cleaning liquid pouch.

---

#### RELATED LINKS

- P. 50 "TR2 Cleaning Liquid Pouch Replacement"
- 

### "CHANGE CL-LIQUID FOR WIPER"

The TR2 cleaning liquid pouch is empty.

Quickly replace it with a new TR2 cleaning liquid pouch.

---

#### RELATED LINKS

- P. 50 "TR2 Cleaning Liquid Pouch Replacement"
- 

### "TIME FOR TRAY CLEANING"

It is time to clean the wiper tray.

After verifying the message, press [ENTER]. Clean the wiper tray, and then replace the tray pads.

---

#### RELATED LINKS

- P. 166 "Replacing the Wiper and the Tray Pad"
  - P. 169 "Cleaning the Wiper Tray"
- 

### "HEAD PROTECTION ACTIVATED"

The ink in use may not be a product specified by Roland DG Corporation.

To clear the message, press [ENTER]. To obtain optimal performance, we recommend that you use ink specified by Roland DG Corporation. To purchase ink, contact your authorized Roland DG Corporation dealer.

### "SHAKE ALL INK POUCH TRAY"

It is time to mix the ink.

---

After verifying the message, press [ENTER]. Remove a pouch tray, shake it 50 times (for approximately 20 seconds), and then reinsert it. Perform this operation for all the pouch trays.

**RELATED LINKS**

---

- P. 43 "Preventing Sedimentation in Inks"
  - P. 119 "Thoroughly Mixing the Ink Periodically"
-

# Error Messages

This section describes the error messages that may appear on the machine's display, and how to take action to remedy the problem. If the action described here does not correct the problem or if an error message not described here appears, contact your authorized Roland DG Corporation dealer.

## "OPTION DRYER IS NOT CONNECTED"

When "OPTION DRYER" is set to "ENABLE" with no auxiliary drying unit connected to the printer. Switch the sub power and main power off, and then connect the auxiliary drying unit to the printer.

## "TEMPERATURE IS TOO LOW \*\*° C"

The temperature of the location where the machine is installed has fallen below the ambient temperature at which the machine can operate.

Operation cannot be continued. Turn off the sub power. The displayed temperature is the current ambient temperature of the installation location. Bring the installed location to a temperature at which operation is possible (20 to 32°C [68 to 90°F]), and then turn on the power.

## "TEMPERATURE IS TOO HIGH \*\*° C"

The temperature of the location where the machine is installed has risen above the ambient temperature at which the machine can operate.

Operation cannot be continued. Turn off the sub power. The displayed temperature is the current ambient temperature of the installation location. Bring the installed location to a temperature at which operation is possible (20 to 32°C [68 to 90°F]), and then turn on the power.

## "CAN'T PRINT CROP CONTINUE?"

The size of the data including the crop marks is larger than the printing area of the loaded media.

To continue performing output without correcting this, press [ENTER]. At this time, the crop marks and the portion extending beyond the printing area are not output. To stop output, stop sending data from the computer, and then raise the loading lever. Make the printing area wider, for example, by replacing the media with a larger piece of media, and then send the data again.

The size of the data being output is too small.

Make the horizontal-direction (scan-direction) size of the data at least 65 mm (2.6 in.). To continue performing output without correcting this, press [ENTER]. At this time, the data is output without printing the crop marks. To stop output, stop sending data from the computer, and then raise the loading lever. Change the size of the data, and then send the data again. There is no limitation on the size of the data in the media-feed direction.

## "SHEET TOO SMALL CONTINUE?"

The size of the data is larger than the printing area of the loaded media

To continue performing output without correcting this, press [ENTER]. At this time, the portion extending beyond the printing area is not output. To stop output, stop sending data from the computer, and then raise the loading lever. Make the printing area wider, for example, by replacing the media with a larger piece of media, and then send the data again.

## "DATA ERROR CANCELING..."

Output was stopped because a problem was found in the received data.

Operation cannot be continued. Completing the data cancellation will clear the message. Check for a problem with the connector cable or the computer, or if the printer data has any defects (a color is designated that cannot be output, etc.). Once the problem or defect has been corrected, send the data again.

**"SHEET SET ERROR SET AGAIN"**

"SHEET TYPE" is set to "OPAQUE", but transparent media was loaded.

Raise the loading lever, set "SHEET TYPE" to "CLEAR", and then reload the media. Lower the loading lever, and then press [ENTER].

**RELATED LINKS**

- P. 28 "Setup of Roll Media"
- P. 35 "Setup of Sheet Media"
- P. 79 "Using Transparent Media"

**"PINCHROLL ERROR LOWER PINCHROLL"**

This message appears when the loading lever was raised during initialization or after the media was loaded.

Press any key to clear the error. Alternatively, the error is cleared automatically after a short wait. Never move the loading lever while output is in progress.

**"WRONG CARTRIDGE 12345678"**

Has an ink pouch that cannot be used been installed?

Remove the pouch tray to clear the error. Use an ink pouch of the specified type.

**"CANCELED FOR PUMP PROTECTION"**

The printer made an emergency stop because a state in which ink was not present continued for 10 minutes or longer while cleaning (normal, medium, powerful, damper, super, or automatic cleaning while sub power was switched off) was in progress or during the first ink filling procedure for the machine.

Operation cannot be continued. Turn off the sub power. After turning the power off, contact your authorized Roland DG Corporation dealer.

**"AVOIDING DRY-UP TURN POWER OFF"**

The print heads were forced to the home position to prevent them from drying out.

Operation cannot be continued. Switch the sub power off, and then back on.

**"SET HEAD HEIGHT TO \*\*\*\*"**

Is the height of the print heads lower than the height specified in the software RIP?

This warning indicates that the height of the print heads is too low for the media thickness specified in the software RIP. The print heads move to a location where you can operate the height-adjustment lever. Adjust to the displayed height, and then press [ENTER].

**RELATED LINKS**

- P. 77 "Changing the Print Head Height"

**"MOTOR ERROR TURN POWER OFF"**

A motor error occurred.

Operation cannot be continued. Turn off the sub power. Next, eliminate the cause of the error, then immediately switch on the sub power. If the machine is allowed to stand with the error uncorrected, the print heads may dry out and become damaged. This error may be caused by such factors as a mistake in loading the media, a media jam, or an operation that pulls the media with excessive force.



**The media has jammed.**

Carefully remove the jammed media. The print heads may also be damaged. Perform head cleaning, and then perform a printing test and check the results.

**Has the media been pulled with excessive force?**

Excessive tension was applied to the media, and additional action is necessary to recover from this state. First, raise the loading lever and adjust the media to create a small amount of slack, and then switch on the sub power.

**"SERVICE CALL \*\*\*\*"**

An unrecoverable error occurred or part replacement that must be performed by a service technician is required.

Note the number displayed, and then switch off the sub power. After you switch off the power, inform your authorized Roland DG Corporation dealer of the number that appeared on the display.

**"CLEANING ERROR"**

The printer made an emergency stop for one of the following reasons.

- Ink ran out during "damper cleaning."
- A pouch tray was pulled out during "damper cleaning."
- A pouch tray was pulled out during the first ink filling procedure for the machine.

Operation cannot be continued. Switch the sub power off by holding down the switch for one second or longer, and then switch the sub power back on again. Afterward, redo the "damper cleaning" or ink filling from the start. However, if the printer stopped partway through "damper cleaning," first execute the "SUPER CL." menu item, and then redo the "damper cleaning."

**RELATED LINKS**

---

- P. 157 "Super Cleaning Method"
-

# Appendix

# Operations When Moving the Unit

---

|                                                                  |     |
|------------------------------------------------------------------|-----|
| Preparing to Move the Machine.....                               | 203 |
| Step 1: Removing the Media .....                                 | 203 |
| Step 2: Circulating the Ink (Only When Using White Ink) .....    | 204 |
| Step 3: Discharging the Wiper Tray Cleaning Liquid .....         | 205 |
| Step 4: Secure the print heads in place using the retainer. .... | 207 |
| Step 5: Reinstalling the Machine .....                           | 208 |

# Preparing to Move the Machine

Before moving the machine, dispose of the discharged fluid and secure the print-head carriage in place. Attempting to move the machine without first performing these preparations may result in damage to internal components due to leaking ink or damage to the print heads.

## IMPORTANT

- Once the preparations for moving the machine are complete, move the machine promptly and turn on the machine as soon as possible after the machine is relocated. If you leave the machine alone without turning it on, the precipitated ink will coagulate and result in problems such as the clogging of the print heads.
- When moving the machine, keep it at a temperature from 5 to 40°C (41 to 104°F) and at a humidity from 20 to 80% (with no condensation). Failure to do so may result in a breakdown.
- Handle the machine with care when moving it, keeping it level (not tilted at an angle) and preventing it from striking other objects.
- After the printer is reinstalled, the media holder adjuster must be adjusted by a suitably qualified worker. This work must be performed by a Roland DG Corporation worker. Contact your authorized Roland DG Corporation dealer.

## Step 1: Removing the Media

### Procedure

#### 1. Remove any media.

If any media has been loaded, remove it.

If no media is loaded, raise the loading lever.

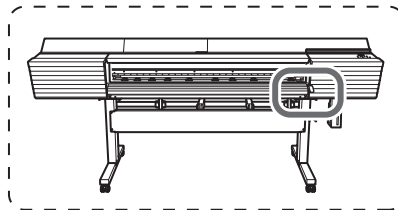
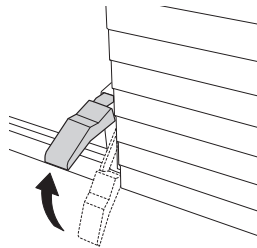

## Step 2: Circulating the Ink (Only When Using White Ink)

\* This operation is not required for the ink types shown below. Proceed to "Step 3: Discharging the Wiper Tray Cleaning Liquid(P. 205)" .

- Four colors: CMYK
- Eight colors: CMYKLcLmLkOr
- Seven colors: CMYKLkOrGr

### Procedure

1. Press [MENU].
2. Press [▼] several times to display the screen shown below.

```
MENU ◀◆
SUB MENU ▶
```

3. Press [▶] once, and then press [▼] several times to display the screen shown below.

```
SUB MENU ◀◆
INK CONTROL ▶
```

4. Press [▶] once, and then press [▼] several times to display the screen shown below.

```
INK CONTROL ◀◆
CIRCULATE INK ↵
```

5. Press [ENTER].

The screen shown below appears, and then the ink circulation starts. The (approximate) remaining time for the procedure is displayed on the screen. (The display shown below is an example. "01:45" = "1 minute and 45 seconds")

```
CIRCULATING INK
>> 01:45
```

Depending on the timing with which the ink circulation is started, the following screen may be displayed and cleaning may start. When cleaning is complete, the ink circulation will start, so wait for the ink circulation to complete. (The display shown below is an example. "01:45" = "1 minute and 45 seconds")

```
CLEANING...
>> 01:45
```

When finished, the screen shown below appears again.

```
INK CONTROL ◀◆
CIRCULATE INK ↵
```

## Step 3: Discharging the Wiper Tray Cleaning Liquid

### Procedure

1. Press [MENU].
2. Press [▼] several times to display the screen shown below.

```
MENU ◀◆
SUB MENU ▶
```

3. Press [▶] once, and then press [▼] several times to display the screen shown below.

```
SUB MENU ◀◆
MAINTENANCE ▶
```

4. Press [▶] once, and then press [▼] several times to display the screen shown below.

```
MAINTENANCE ◀◆
DRAIN TRAY ↵
```

5. Press [ENTER].
6. When the screen shown below appears, remove the drain bottle and discard the discharged fluid.

```
EMPTY
DRAIN BOTTLE ↵
```

### IMPORTANT

When you remove the drain bottle, a few drops of discharged fluid may come out of the machine. Exercise caution to prevent this fluid from soiling your hands or the floor.

- ⚠ CAUTION** Before you detach the drain bottle, be sure to wait for the screen to display "EMPTY DRAIN BOTTLE". After discarding the discharged fluid, promptly attach the drain bottle to the machine.

Failing to follow this procedure may cause discharged fluid to flow out of the tube and spill, soiling your hands or the floor.
- ⚠ WARNING** Never place discharged fluid or ink near an open flame.

Doing so may cause a fire.
- ⚠ CAUTION** To store discharged fluid temporarily, place it in the included drain bottle or in a durable sealed container such as a metal can or polyethylene tank, and cap tightly.

Any spillage or vapor leakage may cause fire, odor, or physical distress.

### IMPORTANT

Do not store discharged fluid in a location where it is exposed to direct sunlight.

When temporarily storing discharged fluid in the included drain bottle, do not store it in a location that is exposed to direct sunlight. The discharged fluid may harden, making the drain bottle unusable. The drain bottle may also deteriorate, leading to discharged fluid leaks.

### IMPORTANT

Dispose of discharged fluid properly, in accordance with the laws in effect in your locale.

Discharged fluid is flammable and contains toxic ingredients. Never attempt to incinerate discharged fluid or discard it with ordinary trash. Also, do not dispose of it in sewer systems, rivers, or streams. Doing so may have an adverse impact on the environment.

7. Quickly attach the emptied drain bottle to the machine once more.
8. Press [ENTER].  
After some time, the sub power turns off.
9. Turn off the main power switch.

**10.** Remove the drain bottle and discard the discharged fluid.

**IMPORTANT**

When you remove the drain bottle, a few drops of discharged fluid may come out of the machine. Exercise caution to prevent this fluid from soiling your hands or the floor.

 **WARNING** Never place discharged fluid or ink near an open flame. Doing so may cause a fire.

 **CAUTION** To store discharged fluid temporarily, place it in the included drain bottle or in a durable sealed container such as a metal can or polyethylene tank, and cap tightly. Any spillage or vapor leakage may cause fire, odor, or physical distress.

**11.** Re-attach the emptied drain bottle.

## Step 4: Secure the print heads in place using the retainer.

Use the retainer that was attached to the bottom of the machine during its installation.

### Procedure

1. Remove the retainer from the bottom of the machine.
2. Use the screw to secure the retainer in the position shown in the figure.

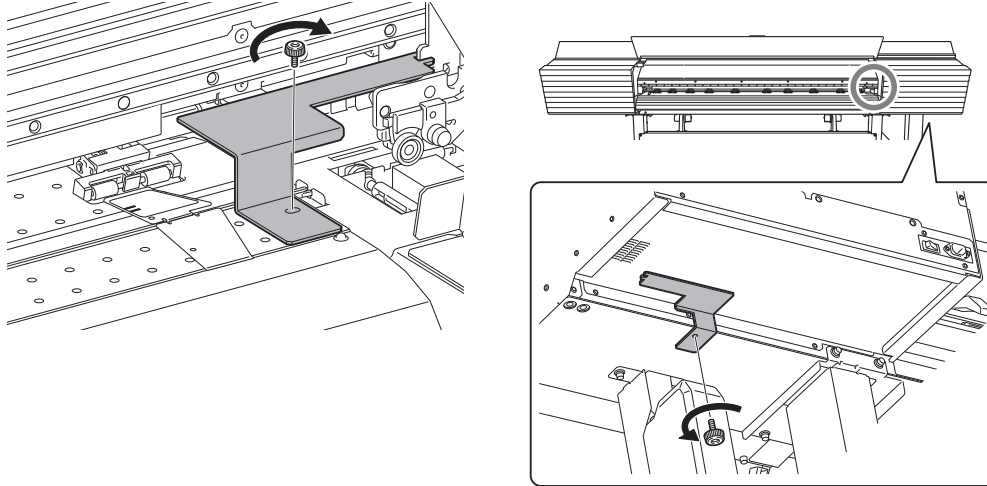



## Step 5: Reinstalling the Machine

### Procedure

1. Once the preparations are complete, move the machine with as little delay as possible.
2. Reinstall the printer immediately, and then remove the retainer securing the print heads in place. For storage, attach the retainer in the position indicated in the figure.

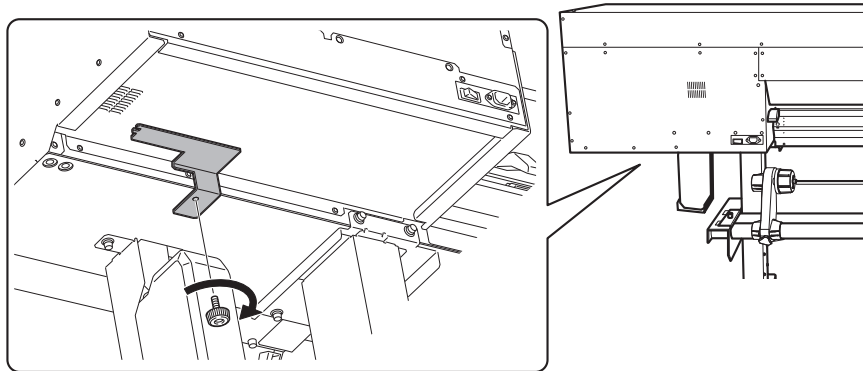

3. Turn on the main power switch.

#### IMPORTANT

To prevent the print heads from being damaged, move the machine with as little delay as possible and switch on the main power as soon as possible after moving the machine. To install the machine again, follow the procedure in the Setup Guide.

4. Press the sub power button.

The screen shown below appears, and then the machine is filled with TR2 cleaning liquid. The (approximate) remaining time for the procedure is displayed on the screen. (The display shown below is an example. "01:40" = "1 minute and 40 seconds")

```
FILLING LIQUID
>>>> 01:40
```

#### MEMO

If the cleaning liquid pouch is empty, or is not attached, the following screen will be displayed. Install a cleaning liquid pouch and press [ENTER].

```
SET CL-LIQUID
FOR WIPER
```

Once the machine is filled with TR2 cleaning liquid, the following screen is displayed and the power turns on.

```
SETUP SHEET
```

#### MEMO

After the printer is reinstalled, the media holder adjuster must be adjusted by a suitably qualified worker. This work must be performed by a Roland DG Corporation worker. Contact your authorized Roland DG Corporation dealer.

### RELATED LINKS

- P. 50 "TR2 Cleaning Liquid Pouch Replacement"

# Main Specifications

---

Maximum Printing Area and Margins ..... 210  
Maximum Printing Area When Using Crop Marks ..... 211  
Media Separation Location during Continuous Printing ..... 212

# Maximum Printing Area and Margins

The printing area along the horizontal plane of the loaded media (the direction in which the carriages move) is determined by the margin setting.

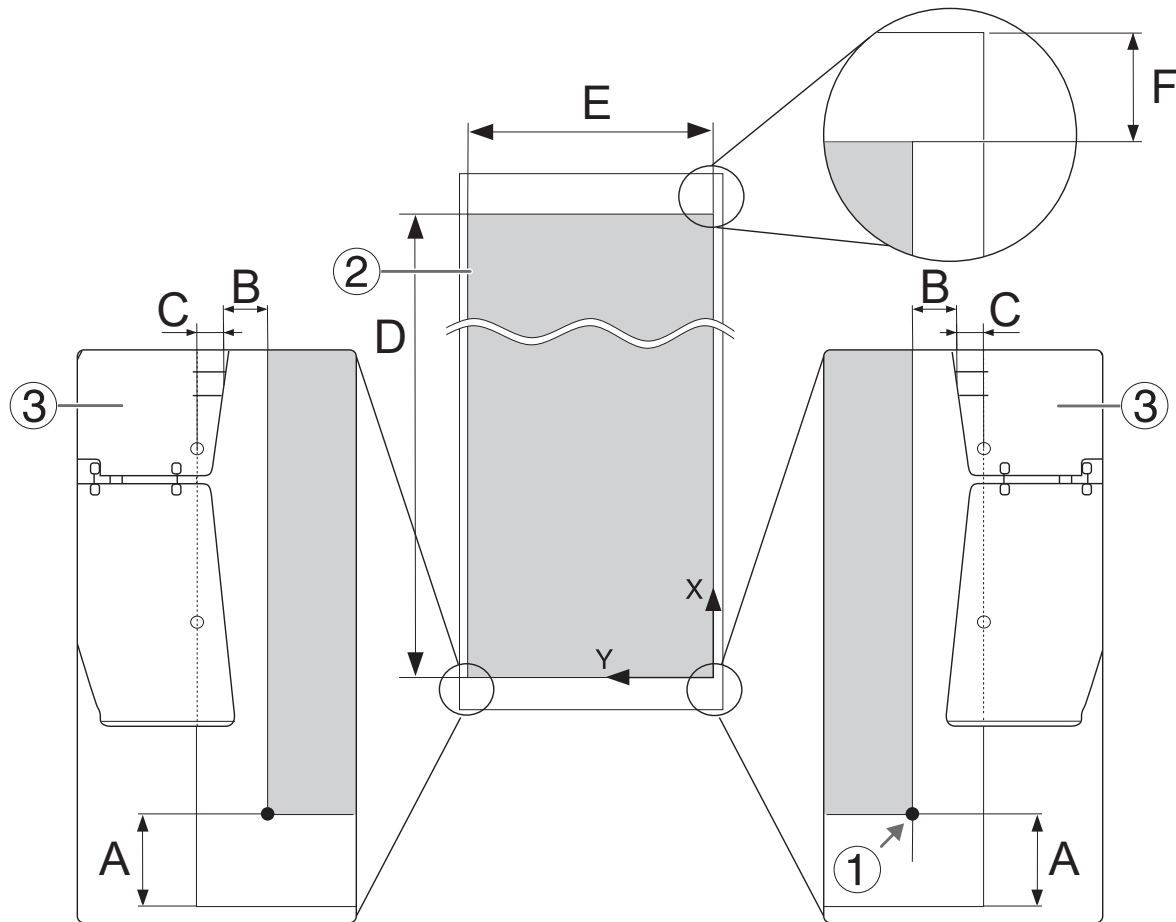

|       |                                                                                                                                                 |
|-------|-------------------------------------------------------------------------------------------------------------------------------------------------|
| ①     | Origin of printing coordinates                                                                                                                  |
| ②     | Printing area                                                                                                                                   |
| ③     | Media clamp                                                                                                                                     |
| A     | 75 mm (3 in.)                                                                                                                                   |
| B     | "SIDE MARGIN" setting value <ul style="list-style-type: none"> <li>• "5 mm"</li> <li>• "10 mm" (Default settings)</li> <li>• "25 mm"</li> </ul> |
| C     | Width clamped by each media clamp: 7 mm (0.28 in.)                                                                                              |
| B + C | Actual margin value*1                                                                                                                           |
| D     | Max. 200,000 mm (7,874 in.)                                                                                                                     |
| E     | Max. 1,615 mm (63.6 in.)<br>* When printing with the media clamps removed                                                                       |
| F     | 105 mm (4.13 in.)                                                                                                                               |

\*1 When the media is set up without attaching the media clamps, B (the "SIDE MARGIN" setting value) alone is used for the margin value without considering C (the width clamped by each media clamp).

## RELATED LINKS

- P. 103 "Set the margins."

# Maximum Printing Area When Using Crop Marks

The maximum printing area when crop marks are used is reduced from the maximum printing area when crop marks are not used by an amount equal to the crop marks.

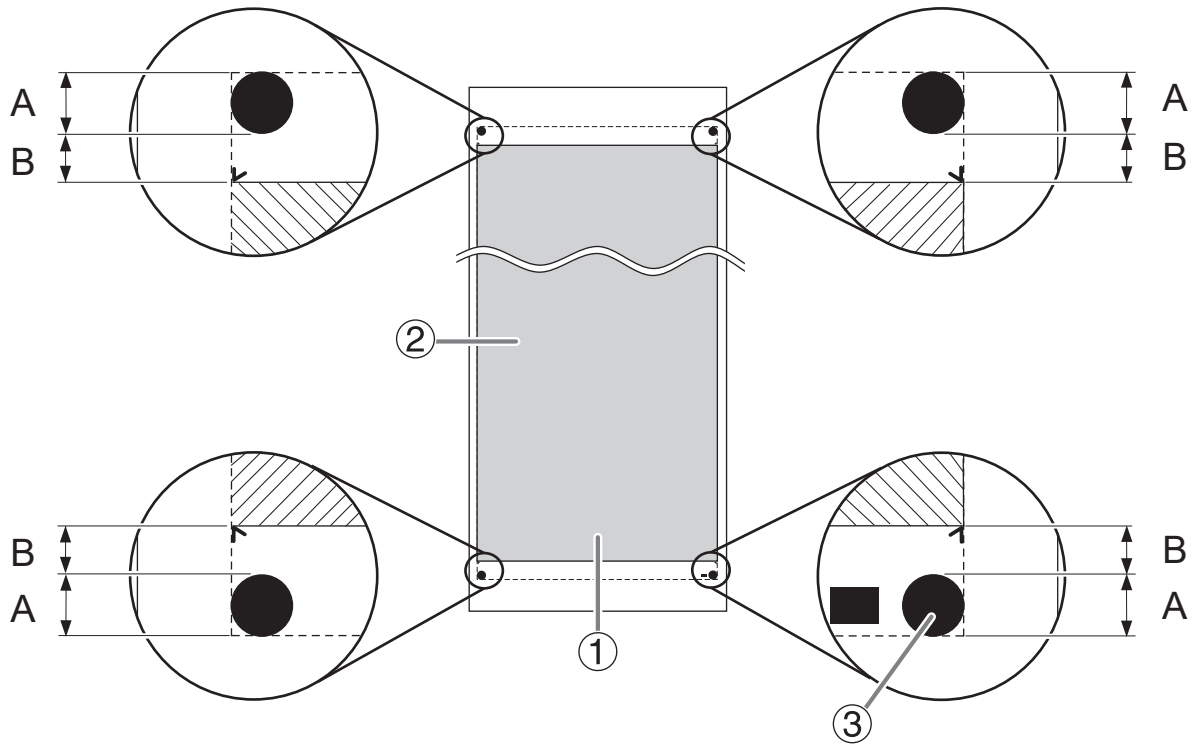

|   |                       |
|---|-----------------------|
| ① | Maximum printing area |
| ② | Printing area         |
| ③ | Crop mark             |
| A | 12.5 mm (0.5 in.)     |
| B | 10 mm (0.4 in.)       |

# Media Separation Location during Continuous Printing

When a command for separating the media is sent from the computer, the separation location on the media is as shown in the figure below.

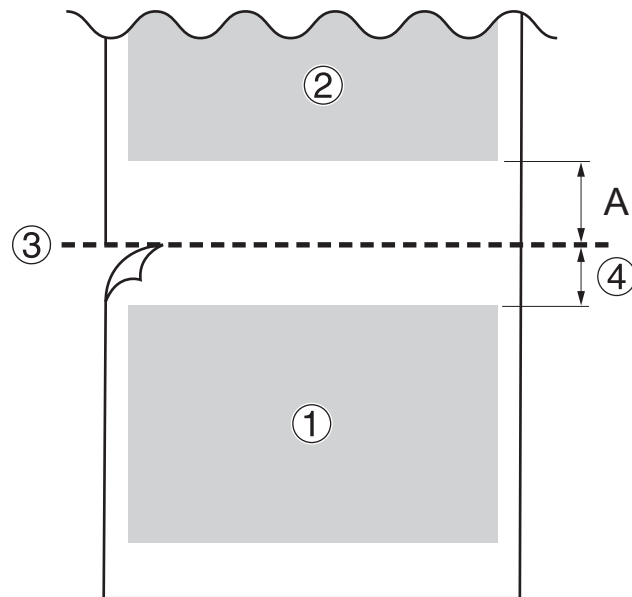

|   |                             |
|---|-----------------------------|
| ① | First page                  |
| ② | Second page                 |
| ③ | Separation location         |
| ④ | Margin (software RIP value) |
| A | 75 mm (3 in.)               |

# Memo

---

This product is equipped with an "eT-Kernel Compact" eT-Kernel and a "PrCONNECT(R)/Pro" TCP/IP protocol stack, both made by eSOL Co., Ltd. eT-kernel and PrCONNECT are registered trademarks of eSOL Co., Ltd.

-----  
Copyright (c) 2012 - 2013, Murata Manufacturing Co., Ltd. All rights reserved.

Redistribution and use in source and binary forms, with or without modification, are permitted provided that the following conditions are met:

- Redistributions in binary form must reproduce the above copyright notice, this list of conditions, and the following disclaimer in the documentation and/or other materials provided with the distribution.

THIS SOFTWARE IS PROVIDED BY THE COPYRIGHT HOLDERS AND CONTRIBUTORS "AS IS" AND ANY EXPRESS OR IMPLIED WARRANTIES, INCLUDING, BUT NOT LIMITED TO, THE IMPLIED WARRANTIES OF MERCHANTABILITY AND FITNESS FOR A PARTICULAR PURPOSE ARE DISCLAIMED. IN NO EVENT SHALL THE COPYRIGHT HOLDER OR CONTRIBUTORS BE LIABLE FOR ANY DIRECT, INDIRECT, INCIDENTAL, SPECIAL, EXEMPLARY, OR CONSEQUENTIAL DAMAGES (INCLUDING, BUT NOT LIMITED TO, PROCUREMENT OF SUBSTITUTE GOODS OR SERVICES; LOSS OF USE, DATA, OR PROFITS; OR BUSINESS INTERRUPTION) HOWEVER CAUSED AND ON ANY THEORY OF LIABILITY, WHETHER IN CONTRACT, STRICT LIABILITY, OR TORT (INCLUDING NEGLIGENCE OR OTHERWISE) ARISING IN ANY WAY OUT OF THE USE OF THIS SOFTWARE, EVEN IF ADVISED OF THE POSSIBILITY OF SUCH DAMAGE.

-----  
Company names and product names are trademarks or registered trademarks of their respective holders.