

SP-300

USER'S MANUAL

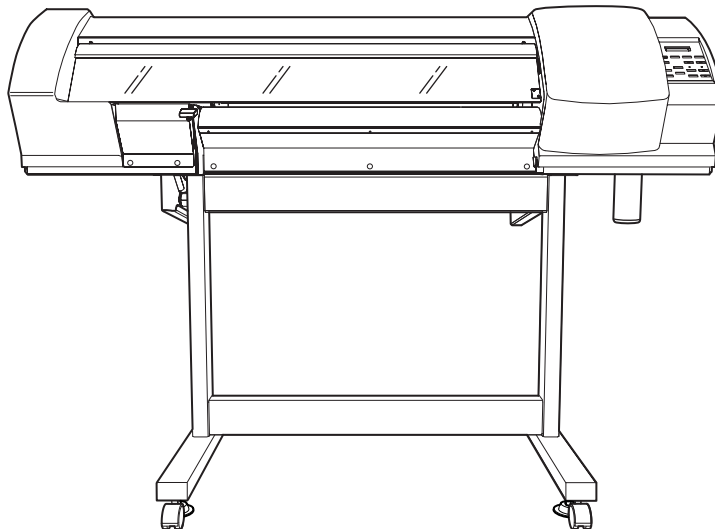

Thank you very much for purchasing this product.

- To ensure correct and safe usage with a full understanding of this product's performance, please be sure to read through this manual completely and store it in a safe location.
 - Unauthorized copying or transferral of this manual, in whole or in part, is prohibited.
 - The contents of this operation manual and the specifications of this product are subject to change without notice.
 - The operation manual and the product have been prepared and tested as much as possible. If you find any misprint or error, please inform us.
 - Roland DG Corp. assumes no responsibility for any direct or indirect loss or damage which may occur through use of this product, regardless of any failure to perform on the part of this product.
 - Roland DG Corp. assumes no responsibility for any direct or indirect loss or damage which may occur with respect to any article made using this product.
-

For the USA

**FEDERAL COMMUNICATIONS COMMISSION
RADIO FREQUENCY INTERFERENCE
STATEMENT**

This equipment has been tested and found to comply with the limits for a Class A digital device, pursuant to Part 15 of the FCC Rules.

These limits are designed to provide reasonable protection against harmful interference when the equipment is operated in a commercial environment.

This equipment generates, uses, and can radiate radio frequency energy and, if not installed and used in accordance with the instruction manual, may cause harmful interference to radio communications.

Operation of this equipment in a residential area is likely to cause harmful interference in which case the user will be required to correct the interference at his own expense.

Unauthorized changes or modification to this system can void the users authority to operate this equipment.

The I/O cables between this equipment and the computing device must be shielded.

NOTICE

Grounding Instructions

Do not modify the plug provided - if it will not fit the outlet, have the proper outlet installed by a qualified electrician.

Check with qualified electrician or service personnel if the grounding instructions are not completely understood, or if in doubt as to whether the tool is properly grounded.

Use only 3-wire extension cords that have 3-prong grounding plugs and 3-pole receptacles that accept the tool's plug.

Repair or replace damaged or worn out cord immediately.

Operating Instructions

KEEP WORK AREA CLEAN. Cluttered areas and benches invites accidents.

DON'T USE IN DANGEROUS ENVIRONMENT. Don't use power tools in damp or wet locations, or expose them to rain. Keep work area well lighted.

DISCONNECT TOOLS before servicing; when changing accessories, such as blades, bits, cutters, and like.

REDUCE THE RISK OF UNINTENTIONAL STARTING. Make sure the switch is in off position before plugging in.

USE RECOMMENDED ACCESSORIES. Consult the owner's manual for recommended accessories. The use of improper accessories may cause risk of injury to persons.

NEVER LEAVE TOOL RUNNING UNATTENDED.
TURN POWER OFF. Don't leave tool until it comes to a complete stop.

For Canada

CLASS A NOTICE

This Class A digital apparatus meets all requirements of the Canadian Interference-Causing Equipment Regulations.

CLASSE A AVIS

Cet appareil numérique de la classe A respecte toutes les exigences du Règlement sur le matériel brouilleur du Canada.



ROLAND DG CORPORATION

1-6-4 Shinmiyakoda, Hamamatsu-shi, Shizuoka-ken, JAPAN 431-2103

MODEL NAME : See the MODEL given on the rating plate.

RELEVANT DIRECTIVE : **EC LOW VOLTAGE DIRECTIVE (73/23/EEC)**

EC ELECTROMAGNETIC COMPATIBILITY DIRECTIVE (89/336/EEC)

WARNING

This is a Class A product. In a domestic environment this product may cause radio interference in which case the user may be required to take adequate measures.



As an ENERGY STAR® Partner, Roland DG Corp. has determined that this product meets the ENERGY STAR® guidelines for energy efficiency.

The International ENERGY STAR® Office Equipment Program is an international program that promotes energy saving through the penetration of energy efficient computers and other office equipment. The program backs the development and dissemination of products with functions that effectively reduce energy consumption. It is an open system in which business proprietors can participate voluntarily. The targeted products are office equipment such as computers, monitors, printers, facsimiles, copiers, scanners, and multifunction devices. Their standards and logos are uniform among participating nations.

Contents

Contents	1
Features of the SP-300	4
⚠ To Ensure Safe Use	5
About the Labels Affixed to the Unit	9
⚠ Pour utiliser en toute sécurité	10
À propos des étiquettes collées sur l'appareil	14
1. Getting Started	15
1-1 Checking Accessories	16
1-2 Names and Functions	17
1-3 Assembling and Installing	19
Installation Environment	19
Step 1: Assemble the Stand	20
Step 2: Install the Included Items	22
Step 3: Remove the Protective Media	24
Step 4: Connect the Power Cord	25
Step 5: Set the Voltage Switches	26
Step 6: Change the Settings for the Language and Unit of Measurement, and Check the Voltage Settings	27
Step 7: Fill Ink	28
Step 8: Match the Machine to the Environment Where Installed	30
Step 9: Install the Blade	31
Step 10: Connect to the Computer	32
2. Basic Operation	33
2-1 Switching the Power On and Off	34
Switching On the Power	34
Switching Off the Power at the End of the Day	35
2-2 Menu Operations	36
Displaying the Menus	36
Basic Menu Operations	37
2-3 Loading Media	38
Loading Roll Media	38
Loading Sheet Media	41
Securing in Place Using the Media Clamps (Only When Printing)	42
2-4 Heater Operation	45
3. Performing Output	47
3-1 Points to Check Before Performing Output	48
Making the Temperature Setting for the Heaters	48
Checking the State of the Printing Heads	49
Checking the Cutting Condition Settings	50
3-2 Performing Output	52
When You're Performing Printing Only	52
When You're Performing Cutting Only	53
When You're Performing Printing and Cutting	53
3-3 Separating the Media	54
3-4 Stopping or Pausing Output Operations	55

4. A wide variety of Operations	57
4-1 Setting the Location Where Output Starts	58
Setting the Start Location	59
4-2 Making Corrections for Printing	60
Feed Correction	60
Bidirectional Correction	62
4-3 Detailed Descriptions of Cutting Conditions	65
4-4 Making Corrections for Printing and Cutting	66
Adjusting Automatically	66
Adjusting Manually	67
4-5 Reloading the Media and Performing Cutting	68
Printing with Crop Marks	68
Aligning Automatically	69
Aligning Manually	70
4-6 Checking the Remaining Ink Level	71
4-7 When Not in Use for a Prolonged Period	72
5. Maintenance	73
5-1 Replacing the Ink Cartridges	74
Care and Handling of Ink Cartridges	74
Replacing with New Ink Cartridges	74
If Ink Runs Out During Printing	75
5-2 Cleaning the Printing Heads	76
Cleaning the Printing Heads	76
If Drop-out Persists Even After Carrying Out Cleaning Several Times	77
Cleaning Using the Cleaning Kit	78
5-3 Other Cleaning Tasks	83
5-4 Replacing the Consumable parts	84
Replacing the Wiper	84
Replacing the Ink-Absorbing Material	86
How to Replace the Blade	87
How to Replace the Separating Knife	88
5-5 Disposing of Discharged Ink	89
5-6 When Moving the Unit	90
6. About the Menus	93
6-1 Menu Flowchart	94
6-2 Detailed Descriptions of the Menus	99
Main Menu	99
Cutting Configuration Menu	101
Heater Configuration Menu	102
Language/unit Menu	102
Maintenance Menu	102

7. What to Do If... 103

- 7-1 What to Do If... 104
 - The Machine Doesn't Run 104
 - Attractive Printing or Cutting Is Impossible 104
 - The Media Becomes Jammed 106
 - What to Do If the Printing Carriage Does Not Operate 106
- 7-2 Responding to a Message 107
 - Action-prompting Messages 107
 - Error Message 107

8. Appendix 109

- 8-1 Specifications 110
- 8-2 Usable Media 111
- 8-3 Printing or Cutting Area 112
 - Maximum Area 112
 - Area When Using Crop Marks 112
 - The Media-cutoff Location During Continuous Printing 113
- 8-4 About Blade Life 114

ECO-SOL INK™ is trademark of Roland DG Corporation.
 ENERGY STAR® is a U.S. registered mark.
 Other company names and product names are trademarks or registered trademarks of their respective holders.

Features of the SP-300

The SP-300 is capable of printing and cutting. This makes possible not only use as either a printer or a cutting machine, but also enables versatile uses such as performing printing followed by cutting.

Using the crop-mark feature enables you to perform cutting with accurate alignment when you remove the media for lamination or the like, then load the media on the machine again.



Also, two heaters are built in: a printing heater and a dryer. These help to fix and dry the ink, thereby enhancing work efficiency. The temperature setting for each can be preset to match the ambient environment and the media used.

Even better weatherability is achieved through use of ECO-SOL INK.







With these features, the SP-300 can accommodate a wide variety of uses, ranging from the creation of stickers and cut-out text and small-lot label printing to the production of panels, outdoor signs, and more.

To Ensure Safe Use

About WARNING and CAUTION Notices

 WARNING	Used for instructions intended to alert the user to the risk of death or severe injury should the unit be used improperly.
 CAUTION	Used for instructions intended to alert the user to the risk of injury or material damage should the unit be used improperly. * Material damage refers to damage or other adverse effects caused with respect to the home and all its furnishings, as well to domestic animals or pets.

About the Symbols

	The  symbol alerts the user to important instructions or warnings. The specific meaning of the symbol is determined by the design contained within the triangle. The symbol at left means "danger of electrocution."
	The  symbol alerts the user to items that must never be carried out (are forbidden). The specific thing that must not be done is indicated by the design contained within the circle. The symbol at left means the unit must never be disassembled.
	The  symbol alerts the user to things that must be carried out. The specific thing that must be done is indicated by the design contained within the circle. The symbol at left means the power-cord plug must be unplugged from the outlet.

WARNING



Do not disassemble, repair, or modify.
Doing so may lead to fire or abnormal operation resulting in injury.



Ground the unit with the ground wire.
Failure to do so may result in risk of electrocution in the event of a mechanical problem.



Do not use with any electrical power supply that does not meet the ratings displayed on the unit.
Use with any other power supply may lead to fire or electrocution.



Do not connect the power cord with other electrical loads on a single electrical outlet.
Doing so may generate heat and cause fire.



Do not use while in an abnormal state (i.e., emitting smoke, burning odor, unusual noise, or the like).
Doing so may result in fire or electrocution. Immediately switch off first the sub power, then the main power, unplug the power cord from the electrical outlet, and contact your authorized Roland DG Corp. dealer or service center.



Do not operate in a location exposed to open flame, sparking, or static electricity, or in a location exposed to high temperatures, such as in the immediate vicinity of a heater. Also, do not place undried media in such locations.
Doing so may result in fire due to combustion of ink or cleaning liquid.



Do not spill combustible liquid over the platen.
Doing so may cause fire.



Use only with the power cord included with this product.
Use with other than the included power cord may lead to fire or electrocution.

⚠ WARNING



Do not store ink cartridges, cleaning liquid, or discharged ink in locations such as the following.

- Near open flame
- Locations exposed to high temperatures, such as in the immediate vicinity of a heater
- Near bleach, chemicals, explosives, or the like

Doing so may cause fire.



Do not place any potentially flammable object on the platen while the heater is in operation.

Doing so may cause fire.

⚠ CAUTION



Ensure adequate ventilation for the work area.

Failure to do so may result in odor, physical distress, or fire.



If ink or cleaning liquid comes in contact with the eyes, immediately flush with running water for at least 15 minutes. If eye irritation continues, seek treatment by a physician.



If ink or cleaning liquid is accidentally swallowed, do not induce vomiting, and immediately seek treatment by a physician.



When storing discharged ink temporarily, place in the included drain bottle or a durable sealed container such as a metal can and polyethylene tank, and cap tightly.

Leakage of discharged ink or its vapor may result in odor, physical distress, or fire.



Before switching on the power, set the voltage switch to match the voltage of the region where the unit is used.

When set incorrectly, the heater may fail to operate normally. The temperature of the heater may rise to undue levels, which may result in fire, or the temperature may fail to rise at the correct speed.



Do not allow ink or cleaning liquid to come into contact with eyes or skin. Do not drink or deliberately smell ink or cleaning liquid.

Doing so may be hazardous to your health.



If ink or cleaning liquid comes in contact with the skin, immediately wash well with soap and water. If irritation or inflammation occur, seek treatment by a physician.



If the odor of the ink or cleaning liquid causes physical distress, move to a well-ventilated location and rest quietly. If dizziness or nausea persists, seek treatment by a physician.



Store ink cartridges out of the reach of children.

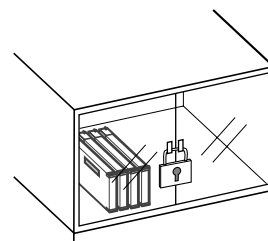



When unplugging the electrical power cord from the power outlet, grasp the plug, not the cord.

Unplugging by pulling the cord may damage it, leading to fire, electrical shock, or electrocution.

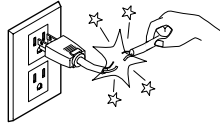

Do not attempt to unplug the power-cord plug with wet hands.

Doing so may result in electrical shock or electrocution.

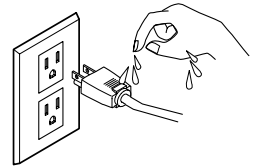

Do not damage or modify the electrical power cord, subject it to excessive bending, twisting, pulling, binding, or pinching, or place any object or weight on it.

Doing so may damage the electrical power cord, leading to fire, electrical shock, or electrocution.

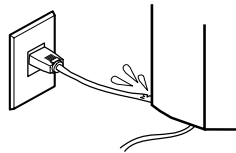

Do not use with a damaged power cord or plug, or with a loose electrical outlet.

Doing so may lead to fire, electrical shock, or electrocution.

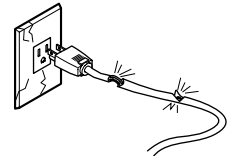

Do not allow liquids, metal objects or flammables inside the machine.

Such materials can cause fire.

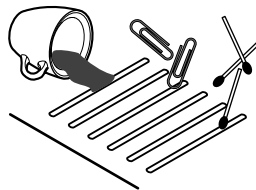

Unpacking, and installation must be carried out by four or more persons.

Otherwise the machine or the stand may fall, resulting in injury.



Use care to avoid pinching the fingers when placing the unit on the stand.

Doing so may result in injury.

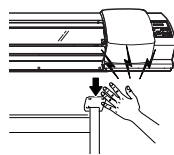

Install in a level and stable location.

Failure to do so may result in the unit tipping over, leading to injury.

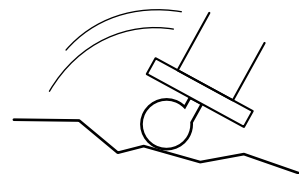

Use the joining screws to secure the unit to the stand.

Failure to do so may result in falling of the unit, leading to injury.

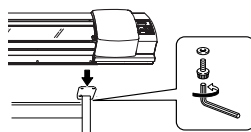

Release the caster locks for the stand before attempting to move.

Otherwise the unit may tip over and cause injury.

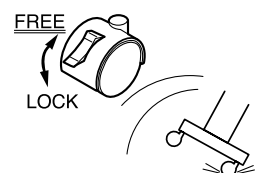

 **Be sure to install the media guide when loading roll media.**

Otherwise the roll may fall and cause injury.

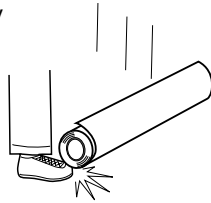

 **Load roll media at the proper position.**

Otherwise the roll may fall, resulting in injury.

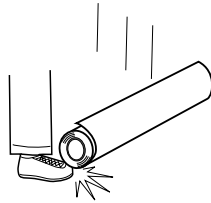

 **When cleaning the unit, be sure to wait approximately 30 minutes or more after switching off the power of the printer until the temperature of the platen falls sufficiently.**

Doing so may cause burns because the platen is hot.

 **Do not touch the control panel while head cleaning or other cleaning is in progress.**

The printing carriage may move and cause injury.

 **Do not touch the platen when the heater is operating.**

Doing so may cause burns because the platen is hot.

 **Before switching on the power, be sure to install the drain bottle.**

Otherwise discharged fluid may leak from the machine.

 **Do not touch the tip of the blade with your fingers.**

Doing so may result in injury, and the cutting performance of the blade will be impaired.

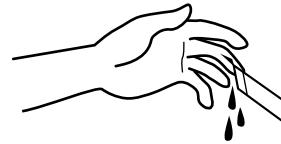

 **Do not touch the tip of the separating knife with your fingers.**

Doing so may result in injury.



 **Do not place hands within the space to the front of the unit while in operation.**

Doing so may result in injury.

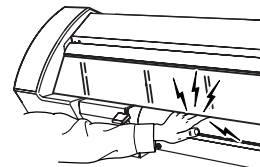

About the Labels Affixed to the Unit

These labels are affixed to the body of this product.
The following figure describes the location and content of these messages.

Front

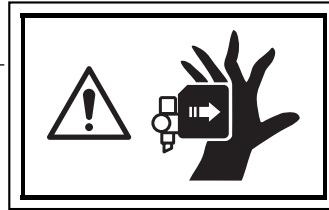
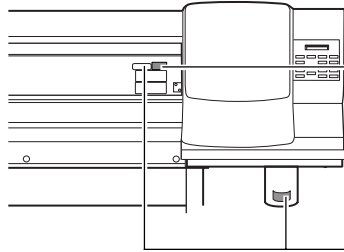

Do not place hands within the space to the front of the unit while in operation.

Left

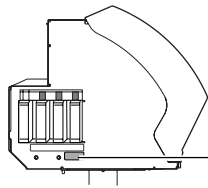

Ink and discharged ink are flammable. Keep away from open flame.



Ink and discharged ink are toxic. Avoid contact with the body. Use only in a well-ventilated area.

Ink Cartridge

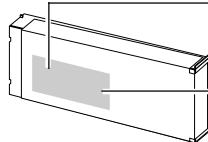

Do not dismantle the cartridge. Keep out of reach of children. Do not store the cartridge in high or freezing temperatures.

Right

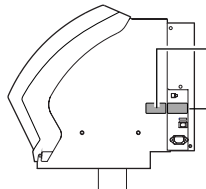

Read manuals before connecting.
Lire les manuels avant d'effectuer les liaisons.
Lesen Sie die Handbücher vor dem Anschluss.
Lea los manuales antes de hacer las conexiones.
Reggere i manuali prima di connettersi.
電源接続前に取扱説明書を必ずお読みください。

Rating label
Use a rated power supply.

Inside the Front Cover

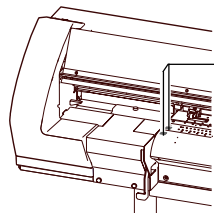

Do not touch the platen. It is hot when the heater is operating.

Inside the Cover

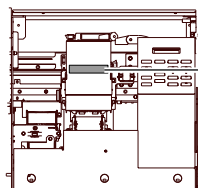

CAUTION : Read all Warnings and Procedures in the "User's MANUAL" before performing any cleaning.



In addition to these symbols, the symbols shown below are also used.

 **Notice** : Indicates information to prevent machine breakdown or malfunction and ensure correct use.



 **Point** : Indicates a handy tip or advice regarding use.

Pour utiliser en toute sécurité

Avis sur les avertissements

 ATTENTION	Utilisé pour avertir l'utilisateur d'un risque de décès ou de blessure grave en cas de mauvaise utilisation de l'appareil.
 PRUDENCE	Utilisé pour avertir l'utilisateur d'un risque de blessure ou de dommage matériel en cas de mauvaise utilisation de l'appareil. * Par dommage matériel, il est entendu dommage ou tout autre effet indésirable sur la maison, tous les meubles et même les animaux domestiques.

À propos des symboles

	Le symbole \triangle attire l'attention de l'utilisateur sur les instructions importantes ou les avertissements. Le sens précis du symbole est déterminé par le dessin à l'intérieur du triangle. Le symbole à gauche signifie "danger d'électrocution".
	Le symbole \otimes avertit l'utilisateur de ce qu'il ne doit pas faire, ce qui est interdit. La chose spécifique à ne pas faire est indiquée par le dessin à l'intérieur du cercle. Le symbole à gauche signifie que l'appareil ne doit jamais être démonté.
	Le symbole \bullet prévient l'utilisateur sur ce qu'il doit faire. La chose spécifique à faire est indiquée par le dessin à l'intérieur du cercle. Le symbole à gauche signifie que le fil électrique doit être débranché de la prise.

ATTENTION



Ne pas démonter, réparer ni modifier.
Démonter, réparer ou modifier l'appareil risque de provoquer un incendie ou de causer un fonctionnement anormal entraînant des blessures.



Mettre l'appareil à la terre avec le fil de mise à la terre.
Ne pas respecter cette consigne peut créer un risque d'électrocution en cas de panne mécanique.



Ne pas utiliser avec une source d'alimentation électrique non conforme à la norme indiquée sur l'appareil.
Utiliser l'appareil avec une autre source d'alimentation risque de provoquer un incendie ou de causer une électrocution.



Ne pas brancher d'autres appareils dans la même prise que l'appareil.
Ne pas respecter cette consigne risque de causer une surchauffe et de provoquer un incendie.



Ne pas utiliser l'appareil s'il est dans un état anormal (p.ex., émission de fumée, odeur de brûlé, bruit inhabituel ou autre anomalie).
Ne pas respecter cette consigne risque de provoquer un incendie ou une électrocution. Couper immédiatement l'alimentation secondaire et ensuite l'alimentation principale, débrancher le fil de la prise et communiquer avec le revendeur ou le centre de service autorisés de la société Roland DG.



Ne pas utiliser près d'une flamme nue, dans un endroit où se produisent des étincelles ou de l'électricité statique, ni dans un endroit où les températures sont élevées, par exemple à proximité d'un appareil de chauffage.
De plus, il ne faut pas placer le support humide dans de tels endroits car la combustion de l'encre ou du liquide nettoyant peut créer un risque d'incendie.



Ne pas répandre de liquide combustible sur la plaque d'exposition.
Cela crée un risque d'incendie.



Utiliser l'appareil uniquement avec le fil électrique fourni.
Utiliser l'appareil avec un autre fil risque de provoquer un incendie ou une électrocution.

⚠ ATTENTION



Ne pas entreposer les cartouches d'encre, le liquide nettoyant ou l'encre usée dans les endroits suivants :

- près d'une flamme nue,
- dans des endroits où les températures sont élevées, par exemple à proximité d'un appareil de chauffage,
- près de javellisants, de produits chimiques, d'explosifs ou autres produits semblables.

Cela crée un risque d'incendie.



Ne jamais poser d'objets potentiellement inflammables sur la plaque d'exposition lorsque le chauffage fonctionne.

Cela crée un risque d'incendie.

⚠ PRUDENCE



S'assurer que le lieu de travail est bien aéré.

Sinon, des odeurs fortes peuvent se dégager et il y a risque de malaises physiques ou d'incendie.



Si de l'encre ou le liquide nettoyant viennent en contact avec les yeux, rincer immédiatement à l'eau courante pendant au moins 15 minutes. Si les yeux sont toujours irrités, consulter un médecin.



Si de l'encre ou du liquide nettoyant sont avalés accidentellement, ne pas provoquer le vomissement, et consulter un médecin immédiatement.



Pour entreposer temporairement l'encre usée, la placer dans un solide contenant scellé, par exemple un contenant en métal et un réservoir en polyéthylène, et fermer hermétiquement.

Les fuites d'encre usée ou la vapeur qui s'en échappe peuvent causer des odeurs fortes, des malaises physiques ou un incendie.



Avant de mettre l'appareil sous tension, régler le sélecteur de tension sur la tension locale.

Le chauffage risque de ne pas fonctionner normalement si la tension n'est pas correctement sélectionnée. La température du chauffage peut augmenter anormalement et provoquer un incendie, ou bien la température peut ne pas augmenter à la vitesse correcte.



Ne pas mettre le liquide nettoyant en contact avec les yeux ou la peau. Ne pas boire ou ni respirer délibérément l'encre ou le liquide nettoyant.

Cela est dangereux pour la santé.



Si de l'encre ou du liquide nettoyant entrent en contact avec la peau, immédiatement laver à fond avec de l'eau et du savon. Si la peau devient irritée ou inflammée, consulter un médecin.



Si l'odeur de l'encre ou du liquide nettoyant cause un malaise physique, amener immédiatement la personne dans un endroit bien aéré et la laisser se reposer. Si l'étourdissement ou les nausées persistent, consulter un médecin.



Ranger les cartouches d'encre hors de portée des enfants.

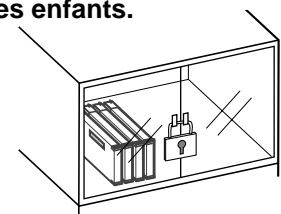



Pour débrancher l'appareil, saisir la fiche et non le fil électrique.

Tirer sur le fil peut l'endommager, ce qui risque de provoquer un incendie ou de causer une décharge électrique ou une électrocution.

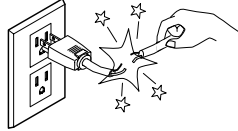

Ne pas débrancher le fil avec des mains mouillées.

Ne pas respecter cette consigne risque de provoquer des décharges électriques ou une électrocution.

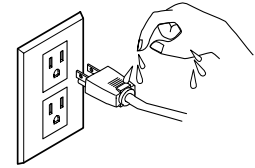

Ne pas endommager ni modifier le fil électrique. Ne pas le plier, le tordre, l'étirer, l'attacher ou le serrer de façon excessive. Ne pas placer d'objet ou de poids sur le fil.

Négliger de suivre cette consigne peut endommager le fil électrique, ce qui risque de provoquer un incendie ou de causer une décharge électrique ou une électrocution.

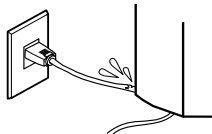

Ne pas utiliser si le fil ou la fiche électriques sont endommagés; ne pas brancher dans une prise mal fixée.

Négliger de suivre cette consigne risque de provoquer un incendie ou de causer une décharge électrique ou une électrocution.

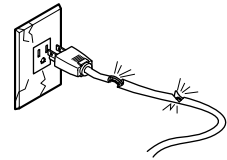

Ne pas laisser de liquides ni d'objets métalliques ou inflammables s'infiltrer dans l'appareil.

De telles infiltrations peuvent provoquer un incendie.

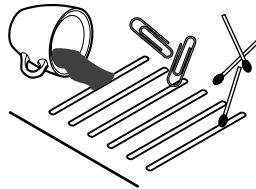

Le déballage, l'installation et le déplacement de l'appareil doivent être effectués par quatre personnes ou plus.

Le non-respect de cette consigne pourrait causer des défauts dans l'appareil entraînant des blessures.



Manipuler avec précaution pour éviter de se coincer les doigts lors de l'installation de l'appareil sur le support.

Une négligence à ce niveau pourrait provoquer des blessures.

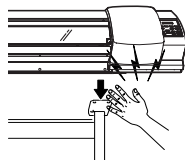

Installer sur une surface stable et de niveau.

Sinon, l'appareil risque de se renverser et de causer des blessures.

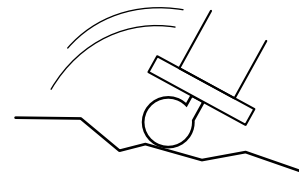

Utiliser les vis fournies pour bien fixer l'appareil sur le support.

Le non-respect de cette consigne pourrait causer des défauts dans l'appareil entraînant des blessures.

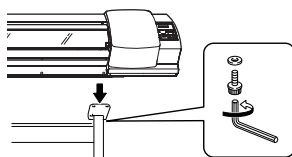

Débloquer le mécanisme d'arrêt des roulettes du support avant de le déplacer.

Sinon l'appareil pourrait se renverser et provoquer des blessures.

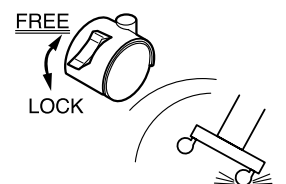



Ne pas oublier d'installer le guide de média quand un rouleau est chargé.

Le rouleau peut tomber et causer des blessures.

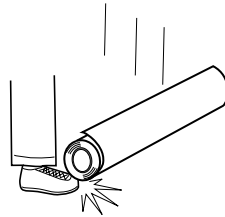

Avant de mettre la machine sous tension, installer la bouteille de vidange, sinon du liquide peut fuir de la machine.



Le rouleau doit être placé quand la barre est en position adéquate.

Une négligence à ce niveau pourrait provoquer la chute du rouleau et causer des blessures.

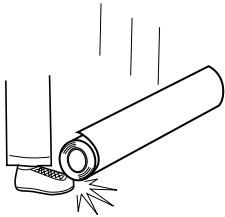

Ne pas toucher à l'extrémité de la lame avec vos doigts.

Une négligence à ce niveau pourrait provoquer des blessures.

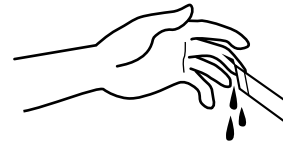

Avant de nettoyer le bloc de chauffage, attendre au moins 30 minutes après l'extinction du chauffage et de l'alimentation secondaire de l'imprimante pour que la température de la plaque d'exposition soit suffisamment basse.

La plaque étant très chaude, il est possible de se brûler.



Ne pas toucher le bout de la lame séparatrice avec les doigts.

Une négligence à ce niveau pourrait provoquer des blessures.



Ne pas toucher le panneau de commande pendant le nettoyage des têtes ou d'autres pièces.

Le chariot d'impression peut bouger et causer des blessures.



Ne pas mettre les mains dans l'espace du devant quand l'appareil est en marche.

Une négligence à ce niveau pourrait provoquer des blessures.

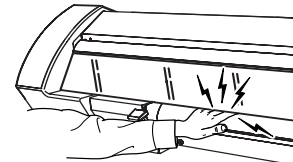

Ne pas toucher la plaque d'exposition lorsque le chauffage fonctionne.

La plaque étant très chaude, il est possible de se brûler.

À propos des étiquettes collées sur l'appareil

Ces étiquettes sont collées à l'extérieur de l'appareil.
Les dessins suivants indiquent l'endroit et le contenu des messages.

Avant

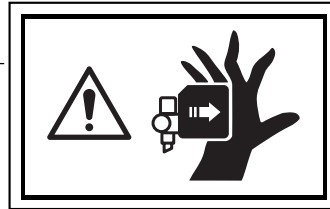
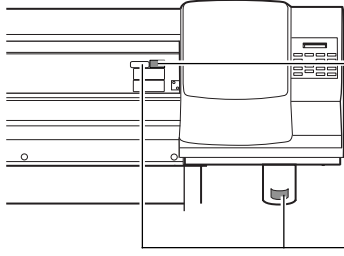

Ne pas mettre les mains dans l'espace devant l'élément quand celui-ci est en marche.

Gauche

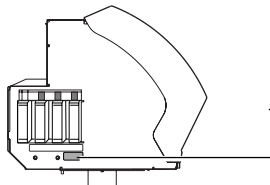

L'encre et l'encre usée sont inflammables. Les garder loin de toute flamme nue.



L'encre et l'encre usée sont toxiques. Éviter tout contact avec le corps. Utiliser uniquement dans un endroit bien aéré.

La cartouche d'encre

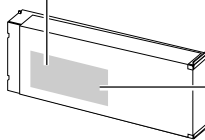

**Ne pas démonter la cartouche.
Conserver hors de la portée des enfants.
Ne pas emmagasiner à des températures hautes ou basses.**

Droite

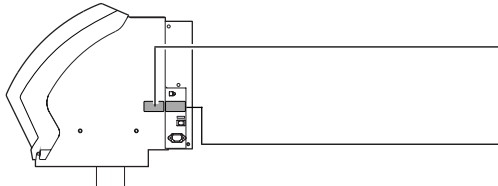

Read manuals before connecting.
Lire les manuels avant d'effectuer les liaisons.
Lesen Sie die Handbücher vor dem Anschluss.
Lea los manuales antes de hacer las conexiones.
Reggere i manuali prima di connetterli.
電源接続前に取扱説明書を必ずお読みください。

**Étiquette des caractéristiques électriques
Utiliser l'alimentation appropriée**

Intérieur de le couvercle

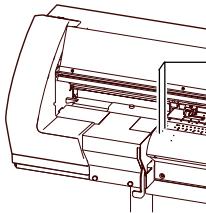

**Ne pas toucher la plaque d'exposition lorsque le chauffage fonctionne.
La plaque étant très chaude.**

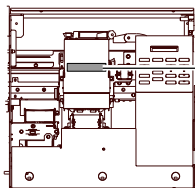

CAUTION : Read all Warnings and Procedures in the "User's MANUAL" before performing any cleaning.

Lire tous les avertissements et toutes les procédures dans le "Mode d'emploi" avant le nettoyage.

1. Getting Started

This section describes what to do when you first open the packing carton, including how to install the machine and connect it to a computer.

1-1 Checking Accessories

The following items are packed together with the unit. Make sure they are all present and accounted for.

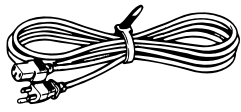

Power cord: 1

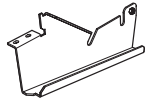

Arm (right): 1

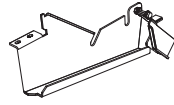

Arm (left): 1

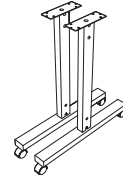

Stand legs: 2

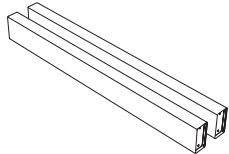

Stays: 2



Shafts: 2

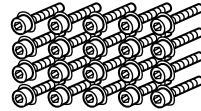

Large bolts : 20



Small Bolts: 2

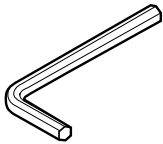

Hexagonal wrench: 1

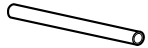

Pipe: 1

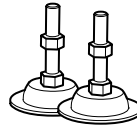

Adjusters: 2



Wrench: 1

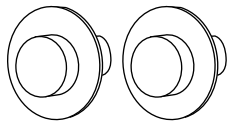

Media flanges: 2

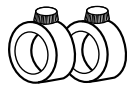

Stoppers: 2

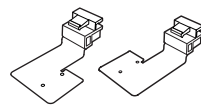

Short media clamp :
1 each on left and right(*1)

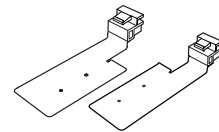

Long media clamp:
1 each on left and right

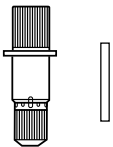

Blade holder: 1
Pin: 1



Blade: 1

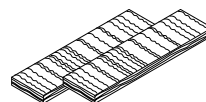

Ink-absorbing materials: 2



Drain bottles: 2

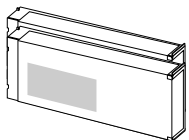

SOL INK cleaning
cartridges: 2

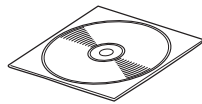

CD-ROMs: 2

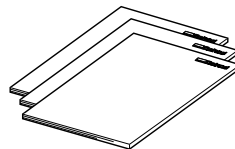

Manuals: 3

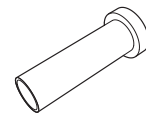

Stay mounting bracket: 1

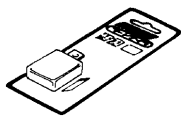

Replacement blade for
separating knife: 1

Cleaning kit



Cleaning sticks: 10



Tweezers: 1

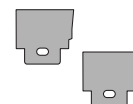

Wipers: 2

*1 The short media clamps are installed on the machine.

1-2 Names and Functions

Front View

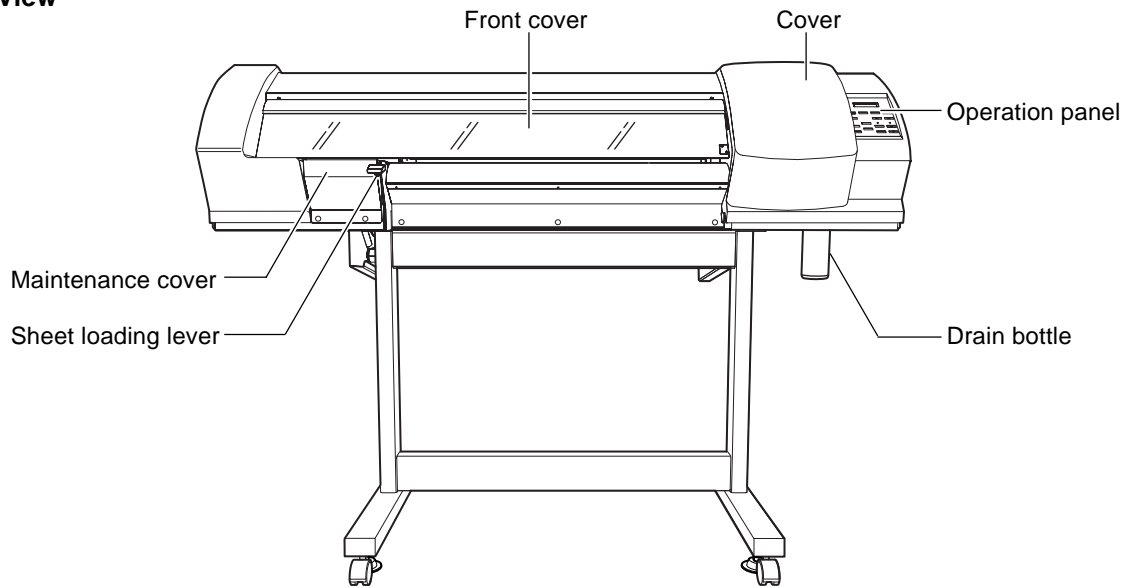

Side View

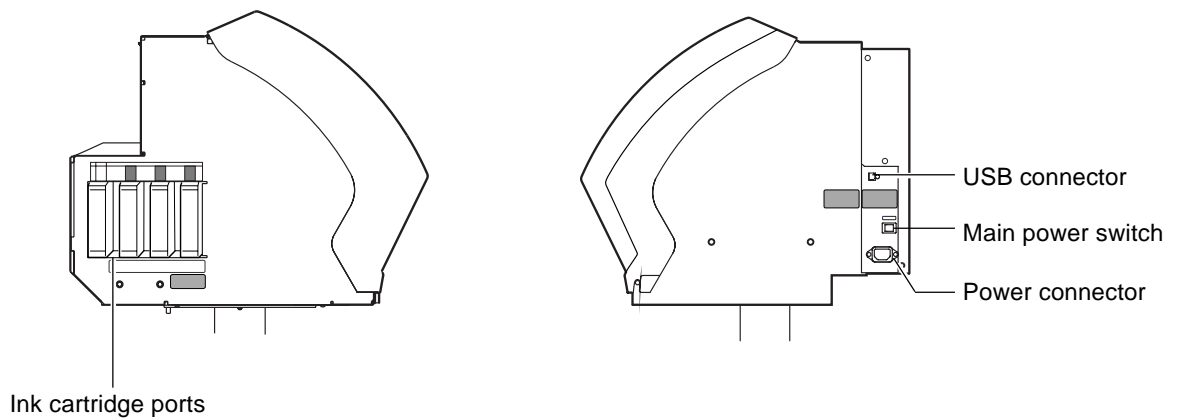

Items Inside the Front Cover

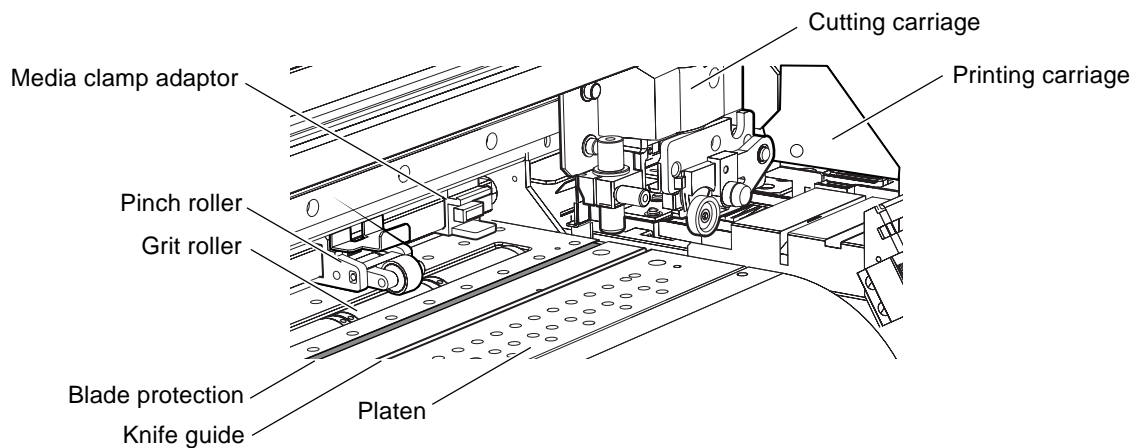

Operation Panel

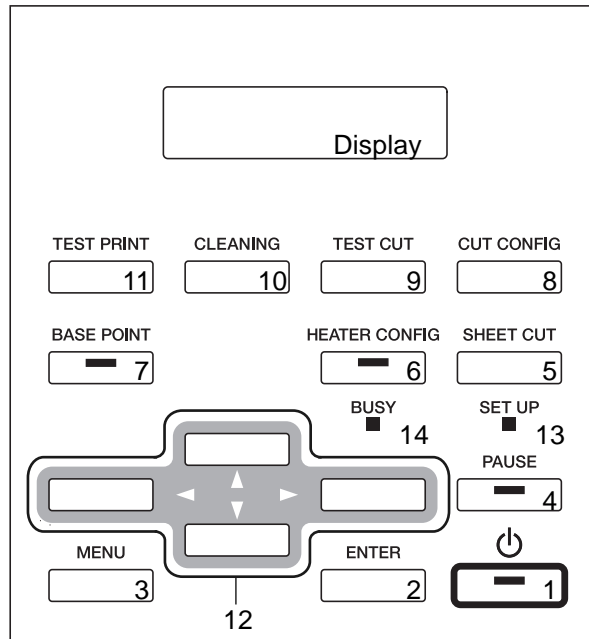

1 [POWER] key

This is used to switch the sub power on and off. When on, the light is illuminated. When in sleep mode, the light flashes slowly.

2 [ENTER] key

This enables setting values and executes operations.

3 [MENU] key

This displays the main menu.

4 [PAUSE] key

This pauses output operation. Pressing it for one second or longer stops output operation. The light is illuminated when operation is paused.

5 [SHEET CUT] key

Pressing and holding this down for one second or longer cuts off the media.

6 [HEATER CONFIG] key

This displays the heater configuration menu. During warm-up the light flashes. When the preset temperature is reached the light remains lit continuously.

7 [BASE POINT] key

This sets the starting position for printing or cutting or align points, and also performs detection of crop marks. The light is illuminated when the starting position is set.

8 [CUT CONFIG] key

This displays the menu for making settings for cutting.

9 [TEST CUT] key

Pressing and holding this down for one second or longer starts the cutting test.

10 [CLEANING] key

Pressing and holding this down for one second or longer starts cleaning of the printing heads.

11 [TEST PRINT] key

Pressing and holding this for one second or longer down starts the printing test.

12 Arrow keys ([▲], [▼], [◀], [▶])

When loading media, you use this to set the print (or cut)-start position.

When at a menu screen, you use this to select setting values or change screens.







13 [SET UP] light

This lights up when media setup ends.

14 [BUSY] light

This lights up when printing or cutting is in progress.

1-3 Assembling and Installing

-  Do not operate in a location exposed to open flame, sparking, or static electricity, or in a location exposed to high temperatures, such as in the immediate vicinity of a heater. Also, never place undried media in such locations. Doing so may result in fire due to combustion of ink or cleaning liquid.
-  Ensure adequate ventilation for the work area.
Failure to do so may result in odor, physical distress, or fire.
-  Unpacking and installation must be carried out by four or more persons.
Otherwise the machine or the stand may fall, resulting in injury.
-  Install in a level and stable location.
Otherwise the machine may tip over and cause injury.
-  Use care to avoid pinching the fingers when placing the machine on the stand.
Failure to do so may result in injury.
-  Use the joining bolts to secure the machine to the stand.
Failure to do so may result in falling of the machine, leading to injury.

Installation Environment

Notice

Never install the machine in any of the following situations, as it could result in breakdown or faulty operation:

- Places with excessive electrical noise.
- Places with excessive humidity or dust.
- Places with poor ventilation, because this machine generates considerable heat during operation.
- Places with excessive vibration.
- Places exposed to strong illumination or direct sunlight.

Never stand on the stand legs. Doing so may damage them.

Never place objects on the machine, as doing so may result in breakdown.

The required installation space for this model is indicated below.

3000 (W) x 1800 (D) x 1800 (H) mm (118-2/16 (W) x 70-7/8 (D) x 70-7/8 (H) in.)

Notice

About the Ambient Temperature During Heater Use

To ensure stable printing quality, we recommend use in an environment where the ambient temperature is 20°C (68°F) or higher.

At low temperatures, warm-up may take a long time, or the heater temperature may fail to reach the preset temperature, or large differences in temperature may occur. Inadequate temperature may result in coarse printing.

Step 1: Assemble the Stand

First assemble the stand, then mount the machine on top of the stand.
To secure the bolts, use the hexagonal wrench and pipe.

- 1 Place the stand legs sideways and attach the stays and adjusters. Tighten the bolts loosely.

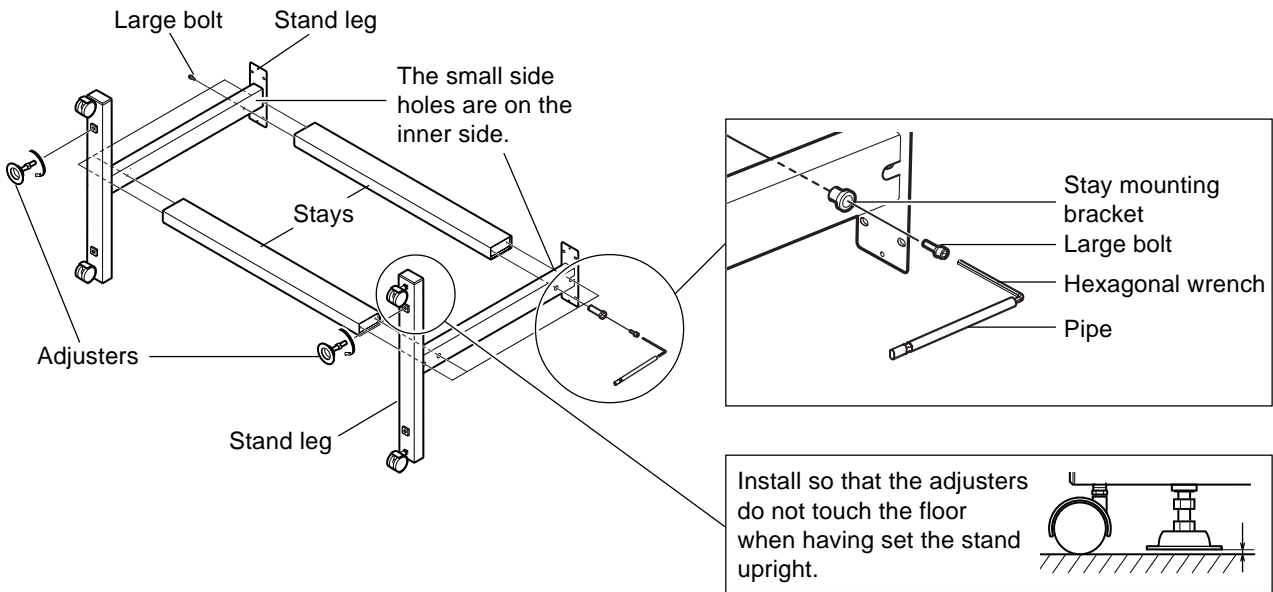

- 2 Set the stand upright and tighten the bolts securely.
Loose bolts may cause the stand to wobble.

- 3 Attach the included small bolts.

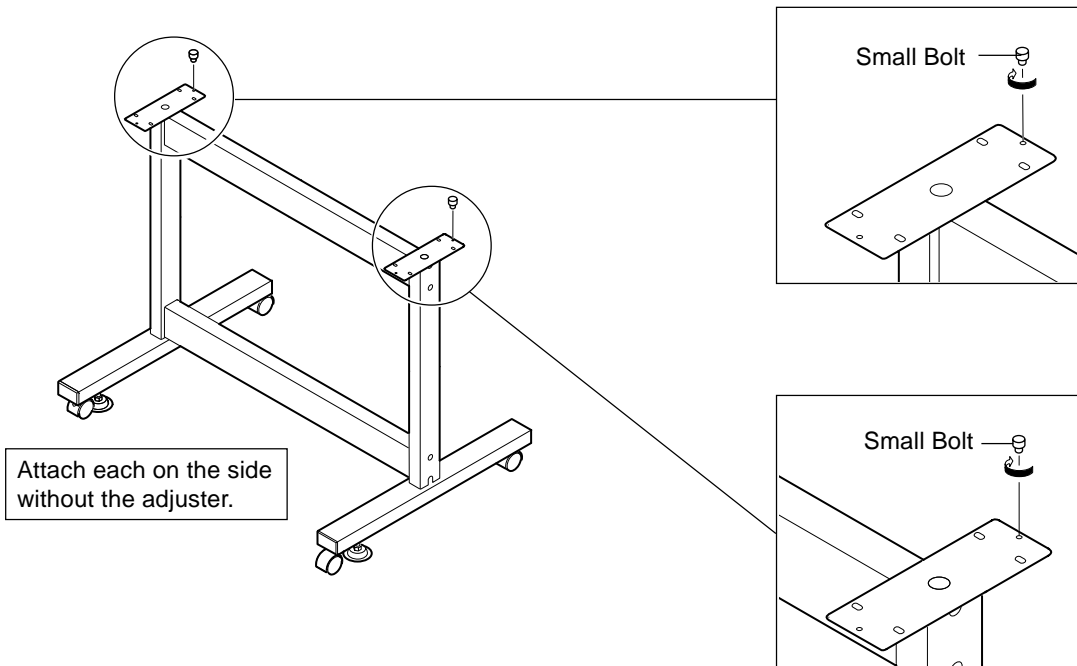

4 Mount the machine and adjust the adjusters to secure the stand in place and keep it from moving.

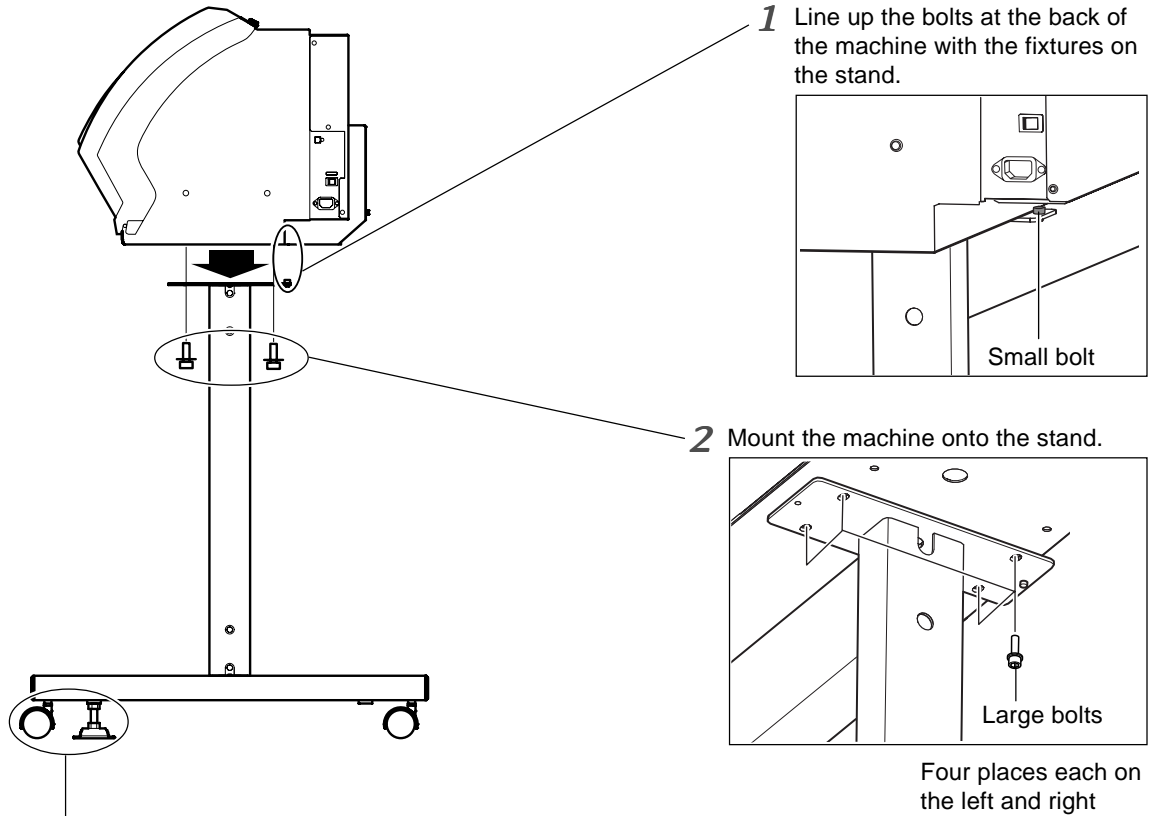

3 Adjust the adjusters to secure the stand in place and keep it from moving.

1. Turn the adjusters in the direction shown in the figure to raise the casters off the floor.

Adjuster
Wrench
Caster

2. Tighten the nut at the top of the adjusters securely.

Wrench

Adjust the clearance between the caster and the floor to 5 millimeters or less.
A larger clearance may make correct printing impossible.

Step 2: Install the Included Items

Install the arms, the shafts, and the drain bottle onto the machine. To secure the bolts, use the hexagonal wrench and pipe.

- 1 Attach the arms onto the back of the machine at the locations shown in the figure. Attach the arms, and secure them using the included large bolts.

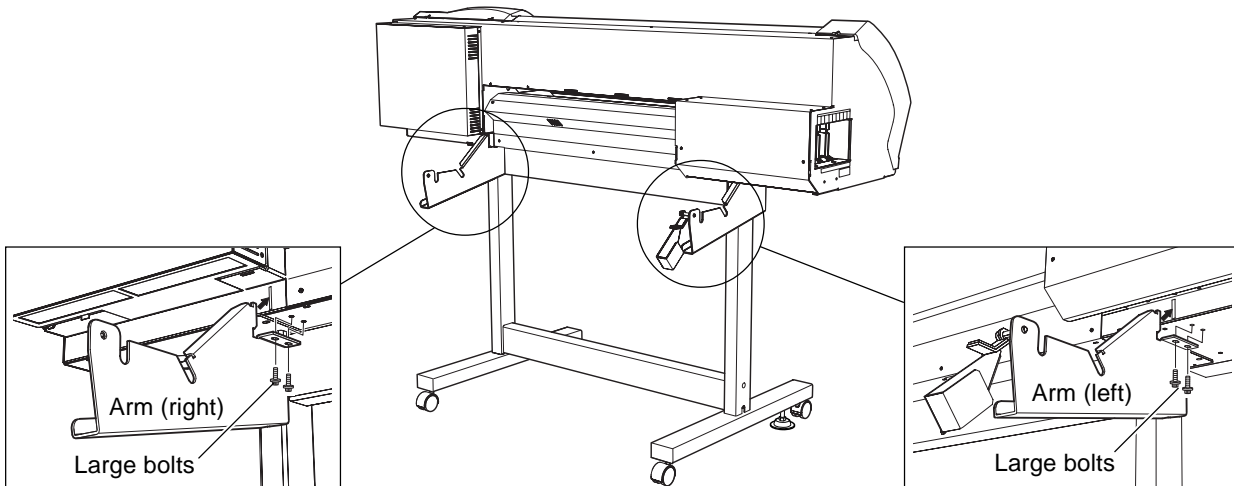

- 2 Pass the stoppers onto both ends of the shaft. When passing the shaft through the stopper, be sure to loosen the screws on the stopper first.

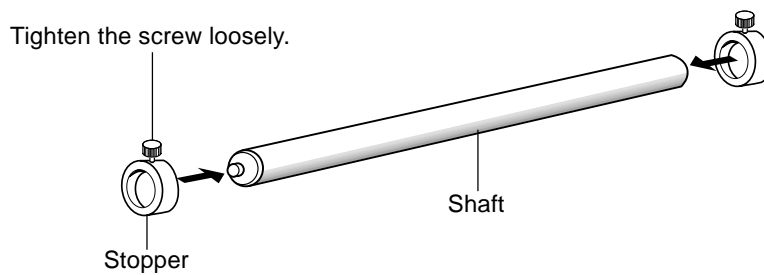

- 3** Attach the two shafts to the arms, and engage the brake. Install the shafts so that the one with the stopper is in front of the back of the machine.

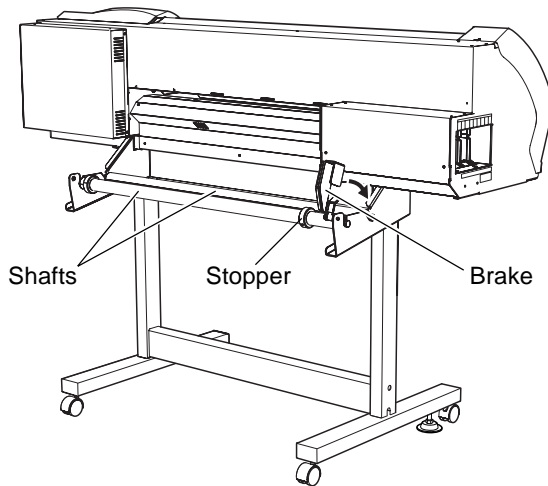
**Point**

Make sure the shaft brake is engaged. Using the machine with the brake disengaged may result in unstable media feed, leading to poor image quality.

- 4** Install the drain bottle. Remove the bottom plug from the bottom surface on the right side of the machine, then screw in the drain bottle in the direction indicated by the arrow. When threading the bottle onto the machine, turn the bottle without applying excessive force.

**Notice**

Leave the drain bottle attached at all times, removing it only when moving the machine or disposing of collected ink.

The bottom plug is needed when moving the machine, so do not discard it.

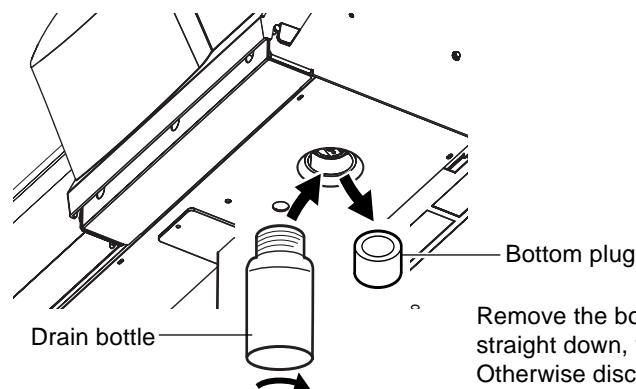
The bottom of the machine

Remove the bottom plug by pulling straight down, without tilting the plug. Otherwise discharged fluid that has collected inside the bottom plug may spill.

Step 3: Remove the Protective Media

The protective media shown below is attached to this machine when it is shipped from the factory. When you have finished installing the machine, remove all protective media.

Front

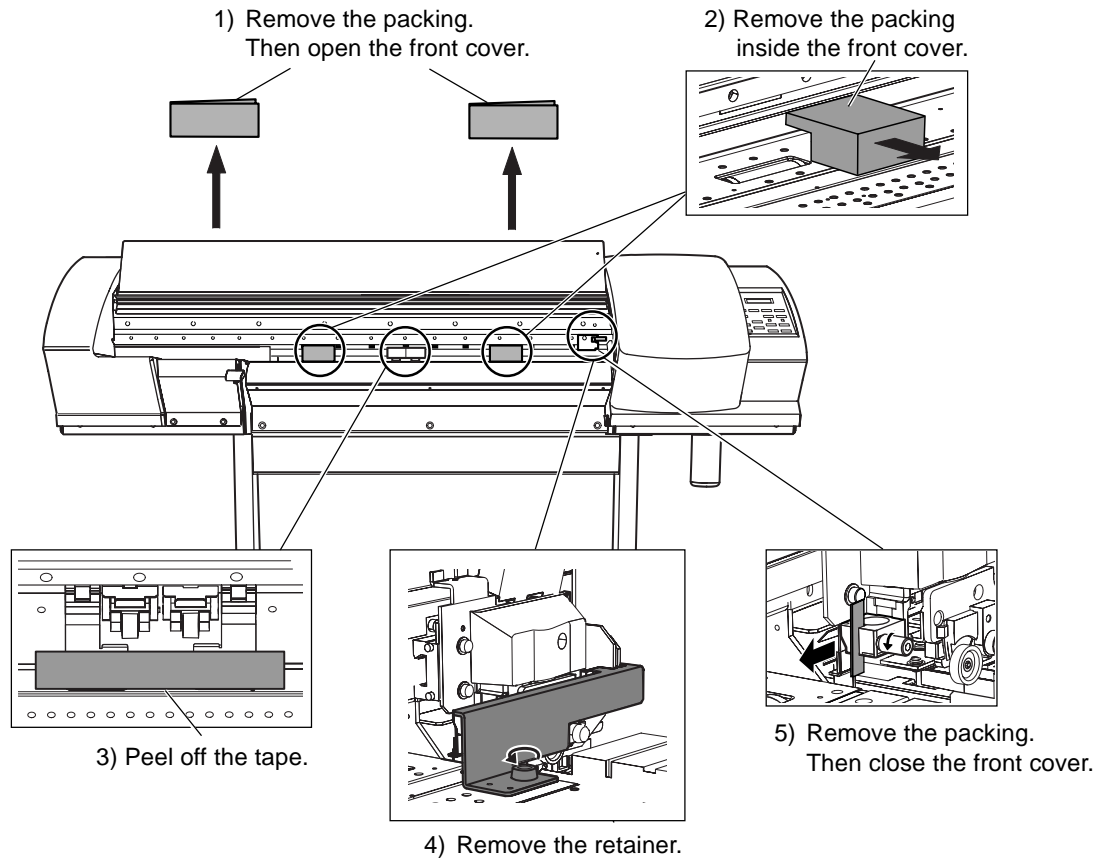

Rear

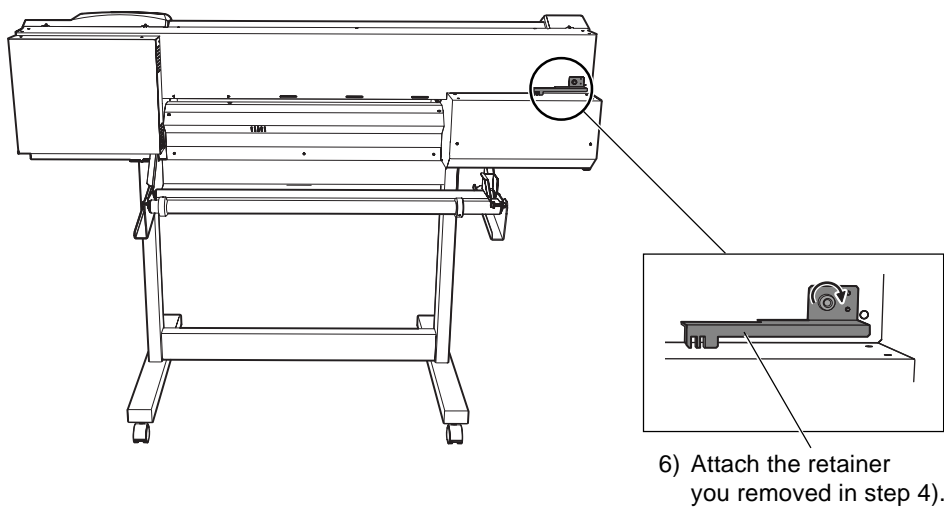

Step 4: Connect the Power Cord



Ground the unit with the ground wire.

Failure to do so may result in risk of electrical shock in the even of a mechanical problem.



Use only with the power cord included with this product.

Use with other than the included power cord may lead to fire or electrocution.



Use only with a power supply of the same rating as indicated on the unit.

Use with any other power supply may lead to fire or electrocution.

Connect the power cord to the machine.



Notice

Securely connect the power cord so that it will not become detached and during operation. Failure to do so may lead to faulty operation or breakdown.

Arrange the power cord and interface connection cable to prevent tripping when moving around the unit.

Right side of the machine

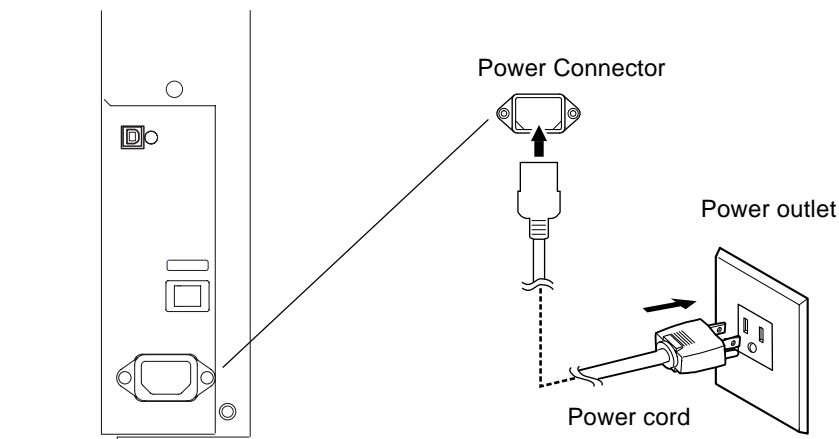

Step 5: Set the Voltage Switches

! Before switching on the power, set the voltage switch to match the voltage of the region where the machine is used. When set incorrectly, the heater may fail to operate normally. The temperature of the heater may rise to undue levels, which may result in fire, or the temperature may fail to rise at the correct speed.

Set the voltage switches to match the voltage of the region where the machine is used.

! Notice
Two voltage switches are located on the bottom of the machine. Make sure both voltage settings are correct, then switch on the power.

The bottom of the machine

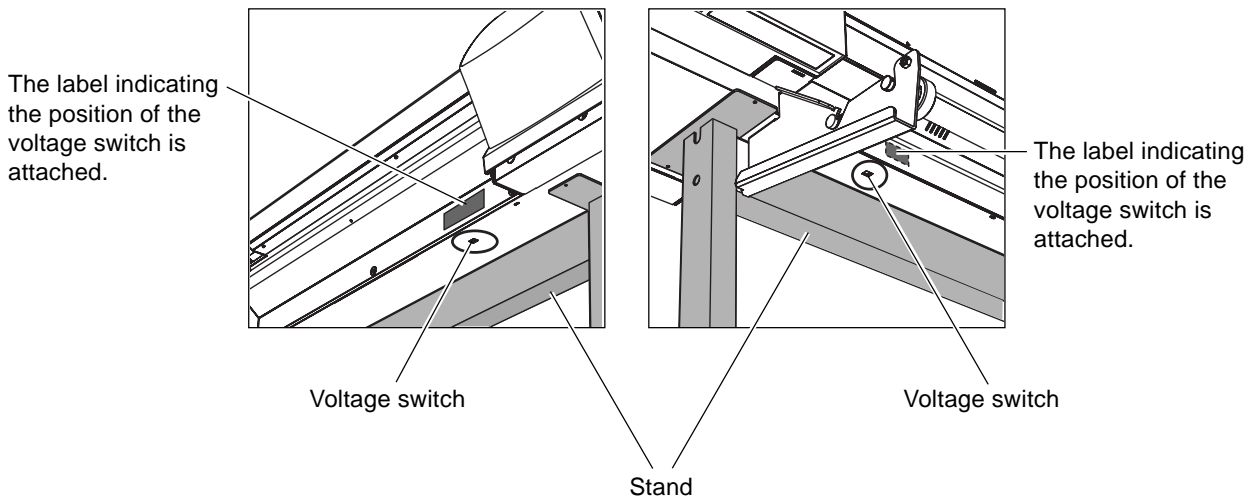

How to Make the Settings for the Voltage Switches

If your region is 100 to 120 V, move the switch to the location where [115 V] is visible. If your region is 220 to 240 V, move the switch to the location where [230 V] is visible. The default setting is [230V].

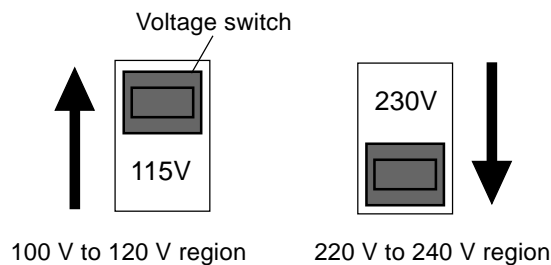

Step 6: Change the Settings for the Language and Unit of Measurement, and Check the Voltage Settings

Change the settings for the language and measurement unit used for the display, and check the settings of the voltage switches.

- 1 Switch on the main power switch on the back of the machine.

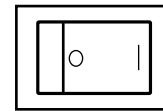

Switch to the "I" side.

- 2 Hold down the [MENU] key and press the [POWER] key.

The sub power is switched on.

The screen in the figure appears on the display.

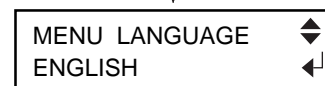
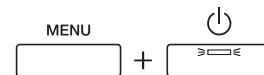

- 3 Use the [▼] key to select [ENGLISH], then press the [ENTER] key.

Make sure the text shown on the display is in English.

- 4 Make the setting for the measurement unit used for lengths.

Use the [▼] key to select [mm] or [INCH], then press the [ENTER] key.

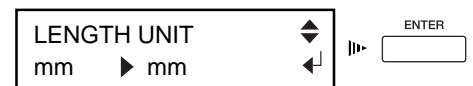

- 5 Make the setting for the measurement unit used for temperatures.

Use the [▼] key to select [°C] or [°F], then press the [ENTER] key.

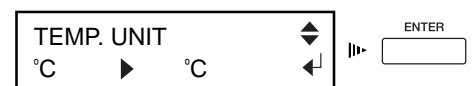

- 6 After a short interval the screen shown in the figure appears.

Make sure the two voltage switches are set correctly, then press the [ENTER] key.

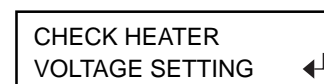

Notice

If the voltage switches have not been set correctly, then stop operation.
Follow the steps below to set the voltage switches, then start over from the beginning.

1. Press the [POWER] key to switch off the sub power.
2. Switch off the main power switch.
3. Refer to the previous section, "Set the Voltage Switches," and make the settings for the voltage switches.

Step 7: Fill Ink



Store ink cartridges out of the reach of children.



If ink or cleaning liquid comes in contact with the eyes, immediately flush with running water for at least 15 minutes. If eye irritation continues, seek treatment by a physician.



Notice

Never drop or allow to fall an ink cartridge. The impact from a fall may cause damage, making it unusable.

When installing and removing an ink cartridge, never rush.

Use only ECO-SOL INK. Never insert any other type of ink cartridge.

Confirming the Ink-insertion Sites

The ink-cartridge ports are located on the side of the machine. Examine the labels affixed to the ink-cartridge ports and make sure of the locations for inserting the cartridges.

Left side of the machine

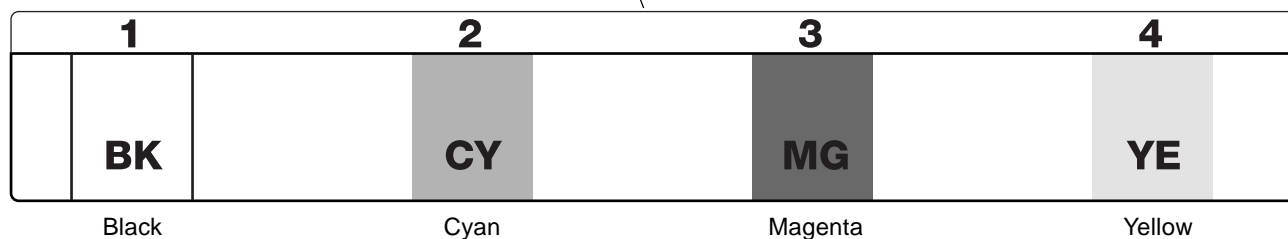
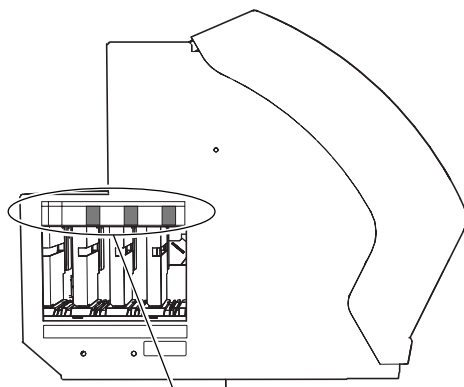

Filling Ink

Installing ink cartridges for the first time after purchase requires two SOL INK cleaning cartridges.

- 1 After checking the settings for the voltage switches, the screen shown in the figure appears. After checking it, then press the [ENTER] key.



- 2 The following screen appears. Make sure the drain bottle is installed at the bottom of the machine, then press the [ENTER] key.



- 3 Insert the SOL INK cleaning cartridges into the ink-cartridge ports shown by flashing on the display. Insert the two cartridges firmly, as far as they will go.

Cleaning starts. Cleaning may take some time. The cartridges are inserted and removed while the operation is in progress. Follow the messages on the display to carry out the procedure.

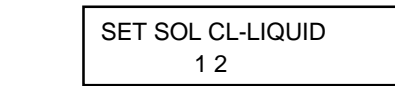

Ink cartridge ports

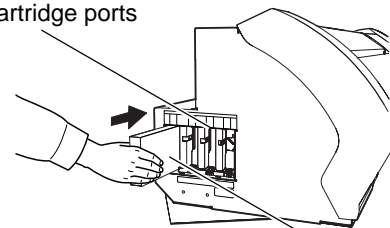

SOL INK cleaning cartridge

- 4 When cleaning ends, the following screen appears. Remove the cleaning cartridges.

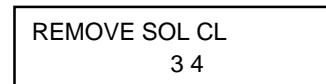

- 5 Gently shake the ECO-SOL INK cartridges for each of the colors and firmly insert them as far as they will go.

Ink filling starts.

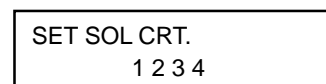

Gently shake,
then insert.

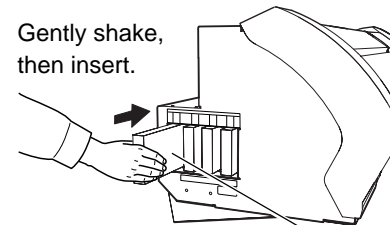

ECO-SOL INK cartridge

Notice

When cutting is performed after printing, the cap tip of the blade holder may scratch the printed surface. If this is the case, increase the amount of blade extension.

- 6 When ink filling ends, the following screen appears.



Step 8: Match the Machine to the Environment Where Installed

The machine performs automatic adjustment to optimize its state to the environment where it is used (temperature and humidity).

Performing automatic adjustment reduces misalignment in the scanning direction (the direction of movement of the carriage) during printing and cutting.

- 1 Press the [MENU] key, then press the [▼] key to select [ENV. MATCH].

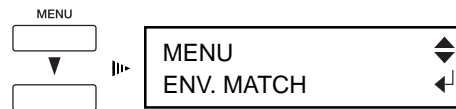

- 2 Press the [ENTER] key.
The printing carriage moves and automatic adjustment starts.
When automatic adjustment ends, the following screen appears.



- 3 Press the [ENTER] key.
The display returns to the screen shown in step 1.

Step 9: Install the Blade



Never touch the tip of the blade with your fingers. Doing so may result in injury, and the cutting performance of the blade will be impaired.



Notice

Never leave the tool-mounting screw tightened. Tightening the screw makes it more difficult to install the blade holder.

Install the blade to the cutting carriage.

- 1** Insert the pin into the blade holder.
- 2** Insert a blade into the blade holder until it snaps into place with an audible click.
- 3** Press the [MENU] key, then press the [▼] key to select [REPLACE KNIFE].
- 4** Press the [ENTER] key.
When the following screen appears, the printing carriage simultaneously moves to the left.
- 5** Open the front cover, then loosen the screw shown in the figure.
- 6** Support the tool-mounting screw from below and install the blade holder.
- 7** Tighten the screw.
Tug the blade holder upward to make sure it does not come loose.
- 8** Close the front cover, then press the [ENTER] key.

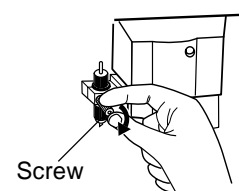
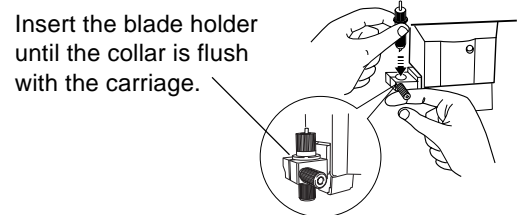
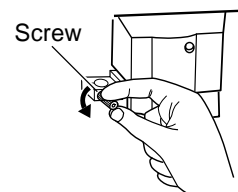
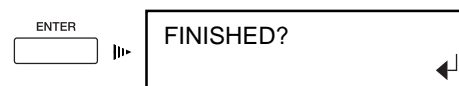
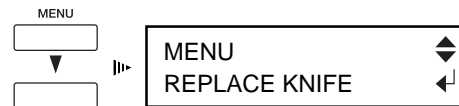
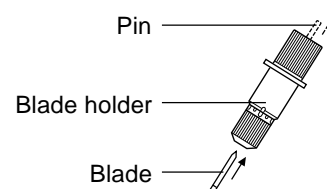
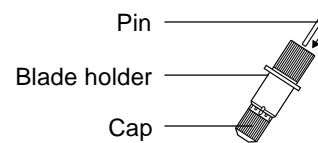

Point

If installed without supporting the screw in this way, cutting quality may become poor.

Step 10: Connect to the Computer

Be sure to make the connection between the machine to the computer during the course of installing the driver. If the cable connection is made before you start installation of the driver, driver installation may fail and the machine may become unusable.

Use a USB cable to make the connection to the computer. Cables are available separately. One which you are sure matches the model of computer being used should be selected.

Notice

Use a shielded USB cable having a length of three meters or less. Never use a USB hub or the like.

Arrange the power cord and interface connection cable to prevent tripping when moving around the unit.

Never attempt to connect a USB cable before starting installing the driver.

Make the cable connections as shown in the figure below. For more information about the connection procedure and driver installation, refer to the documentation for the driver.

Right side of the machine

Be sure to make the connection between the machine to the computer during the course of installing the driver.

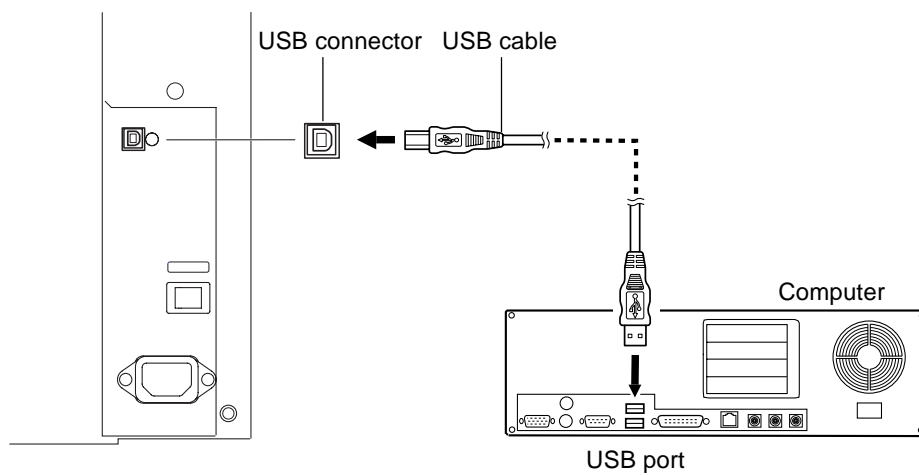

2. Basic Operation

This describes such basic operations as how to switch the power on and off, menu operations, and how to load and set up media.

2-1 Switching the Power On and Off

There are two power switches on the machine; the main power switch and the [POWER] key. Once you have switched on the main power, you should normally leave it on.

In day-to-day use, you switch the machine on and off using only the sub power.

Switching On the Power

Press the [POWER] key to switch the sub power on.

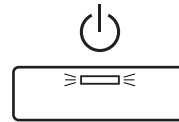

The [POWER] light lights up.

Notice

Points to Keep in Mind When Switching the Power On and Off

Never switch off the main power while the sub power is switched on. The printing heads may be left uncapped (that is, the printing carriage may remain over the platen). If the machine is allowed to stand with the printing heads uncapped for a prolonged period, the printing heads may become irreversibly clogged.

Before switching off the main power, be sure to hold down the [POWER] key for one second or longer to switch off the sub power.

If the printing carriage stops while over the platen, press the [POWER] key to reset the power. The printing carriage moves and the printing heads are capped.

If the printing carriage does not move even when you reset the power using the [POWER] key, go to "7-1 What to Do If..." and refer to "What to Do When the Printing Carriage Does Not Move."

Switching Off the Power at the End of the Day

Press and hold down the [POWER] key for one second or longer.
The sub power is switched off.

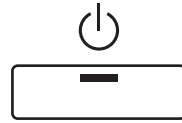

The [POWER] light goes out.

Notice

Raise the sheet loading lever to leave the pinch rollers raised when not in use.
Deformation may occur if left lowered for a prolonged period.

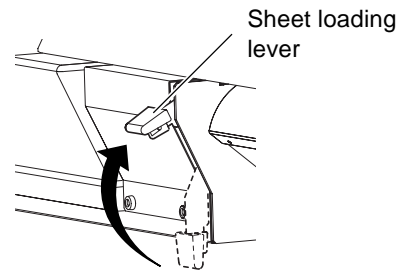

Point

The Power-saving Feature

This machine is provided with a power-saving feature that switches to a low-power "sleep mode" when a fixed interval passes with no operation. The factory default for the time after which the machine switches to the sleep mode is 30 minutes. You can change the setting for the time of the shift to the sleep mode. You can also switch off the power-saving feature. For more information, go to "6-2 Detailed Descriptions of the Menus" and refer to [SLEEP].

When the machine enters the sleep mode, the [POWER] light flashes slowly. Also, heater operation stops. Normally the display goes blank, although it may not go blank in the event of an error message or the like.

To cancel the sleep mode, perform any of the following operations.

- Press any key on the operation panel.
- Send data from the host computer (when media is loaded).
- Open the front cover or the like.
- Move the sheet loading lever.

To reduce power consumption, we recommend leaving the power-saving feature enabled and setting the interval until the sleep mode is activated to a time of 30 minutes or less.

2-2 Menu Operations

Displaying the Menus

Pressing the following buttons displays the corresponding menu screens.

MENU



Main menu

CUT CONFIG



Cutting configuration menu

HEATER CONFIG



Heater configuration menu

When you have displayed a menu, pressing the key for displaying the menu a second time returns the display to the top menu. For more information about the top menu, refer to the following section, "Basic Menu Operations."



Point

For Detailed Information on Using the Menus:

- 3-1 "Points to Check Before Performing Output -- Making the Temperature Setting for the Heaters"
"Points to Check Before Performing Output -- Checking the Cutting Condition Settings"
- 6-1 "Menu Flowchart"
- 6-2 "Detailed Descriptions of the Menus"

Basic Menu Operations

This section describes the items on the main menu. For more information about the heater configuration menu and the cutting configuration menu, see "3-1 Points to Check Before Performing Output."

How to View the Display

Top Menu

When media is loaded, the display shows the printable (or cuttable) width. This screen is called the "top menu."

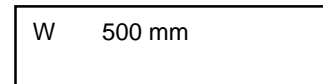

Top menu

Menu Screen

The figures show examples of main-menu screen displays. The operations that you can perform when a symbol is displayed are described below.

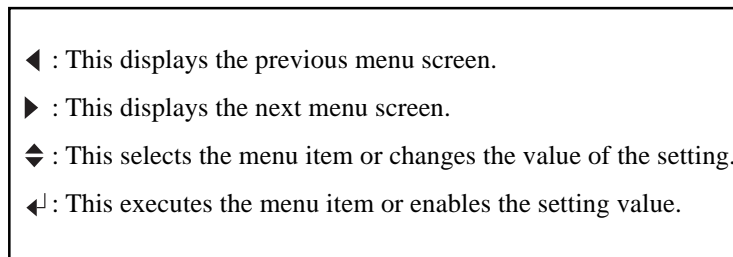

Pressing the [▲] and [▼] keys displays other menu items under [ADJUST BI-DIR].

Pressing the [◀] key returns you to the previous menu screen.







Pressing the [ENTER] key executes a printing test.



Basic menu operations



When you are at the main menu, the keys function as follows.

- 



 This selects a menu item or changes the value of a setting.
- 

 This displays a menu that is one level lower.
- 

 This displays the menu that is one level higher.
- 

 At any menu screen, pressing the [MENU] key returns you to the top menu.
- 

 This executes a menu item or enables a setting value. The value for any setting is enabled only by pressing the [ENTER] key.

Point

Neither printing nor cutting is performed while menu settings are being made. When you have finished making menu settings, press the [MENU] key to go back to the top menu.

2-3 Loading Media

! When loading roll media, be sure to install the shafts.
Otherwise the roll may fall and cause injury.

! Load roll media at the proper position.
Otherwise the roll may fall, resulting in injury.

! Notice

Never touch the rail or the inner sides of the covers.
Touching the area may cause the fingers to be soiled by grease or ink, and may result in diminished image quality.

Loading Roll Media

- 1 Open the front cover.
- 2 Line up the media flanges with the edges of the roll media, aligning them with the inner diameter of the core of the roll media.

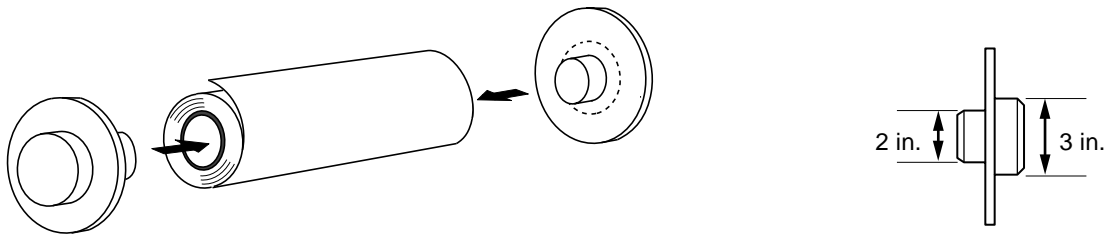

- 3 Place the roll media on the shaft.
Pass the end of the media between the pinch rollers and the grit rollers so that it extends from the front of the machine.

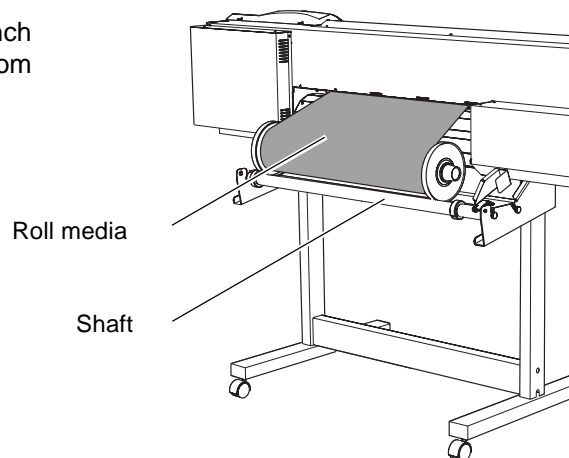

- 4** Load the media as shown in the figure below. Position the media so that its left edge is over grit roller A, B, or C and its right edge is over the grit rollers on the right side as viewed. Align the media so that it is straight, and move the pinch rollers so that they are positioned above the grit rollers. Also position the pinch rollers at the two edges of the media.

Inside the front cover

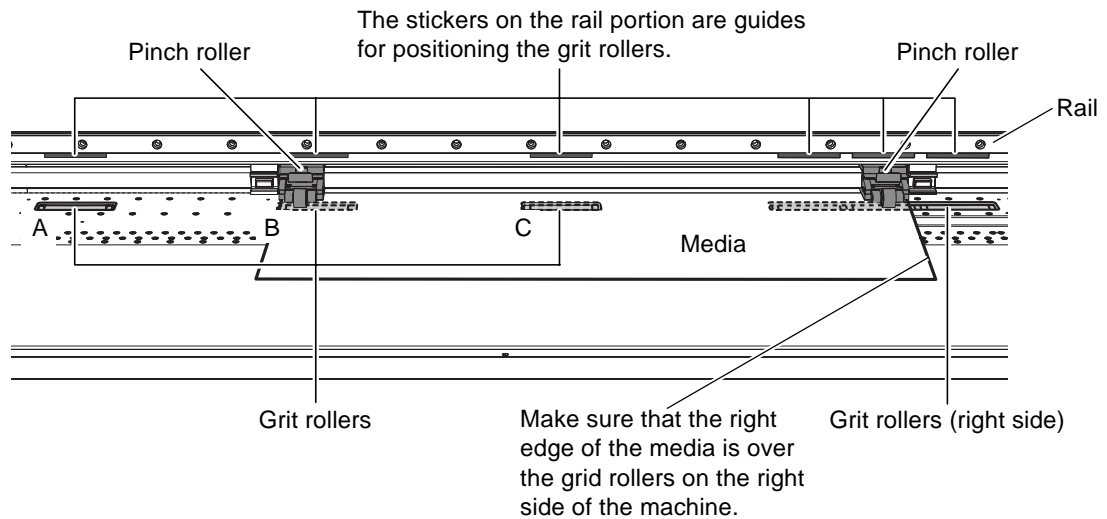

Rear view

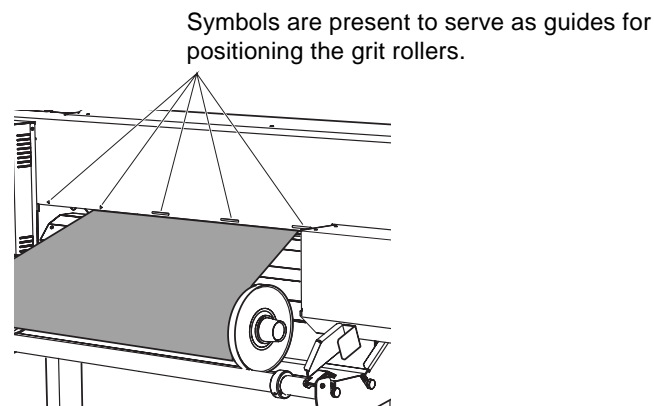

- 5** Align the left and right stoppers with the width of the media and tighten the screws to secure in place.

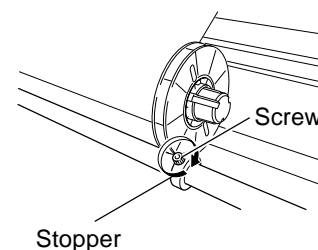

- 6** Pull out the media so that at least 50 cm (20 in.) hangs down at the front of the machine.

- 7** Turn the media flanges by hand to take up the media to a location where the portion hanging from the front of the machine is positioned over the sensor. .

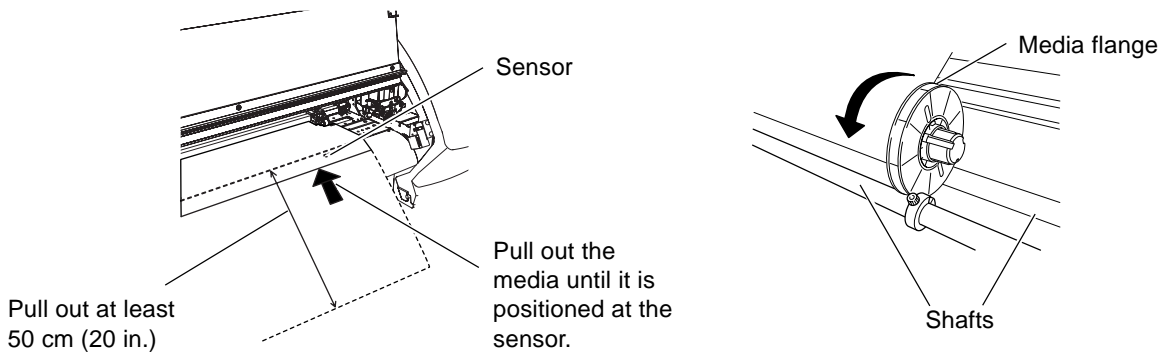

- 8** With the media that is pulled out from the roll stretched taut with no slack, lower the sheet loading lever.

The pinch rollers descend to hold the media in place. The [SET UP] light begins to flash and the screen in the figure appears.

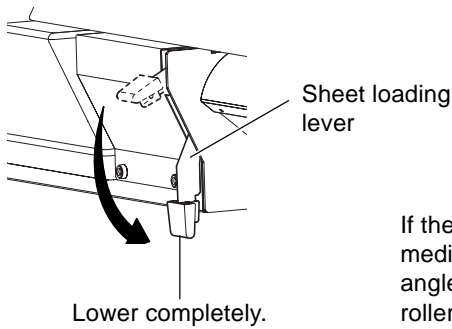

If there is slackness in the loaded media, the media may move at an angle and come loose from the pinch rollers.

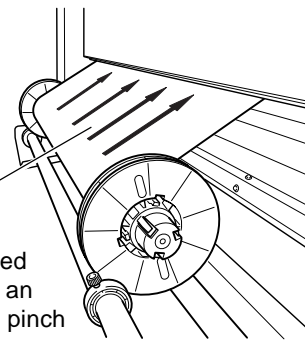

- 9** Close the front cover. This detects the width of the media and displays the printable width. The heater temperature also begins to rise. The [SET UP] light lights up.

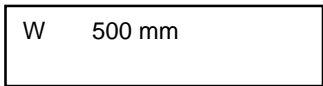

Point

For more information about the operation of the heaters, refer to "2-4 Heater Operation."

If a pinch roller is positioned over an area where there is no grit roller, the screen shown in the figure appears when you close the front cover. Check the positioning of the pinch rollers and make sure they are aligned at the correct locations.

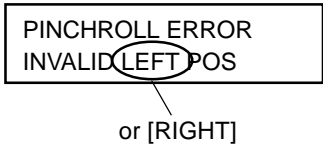

Notice

If the machine is to remain unused for an extended period, remove the roll media from the machine and store it. If roll media is left mounted on the machine for an extended period, the entire roll may warp, resulting in poor printed image quality or motor errors.

Loading Sheet Media

As with standard-size media, make sure of the following points when loading sheet media.

■ Front View

Align the front edge of the media with the location shown in the figure.

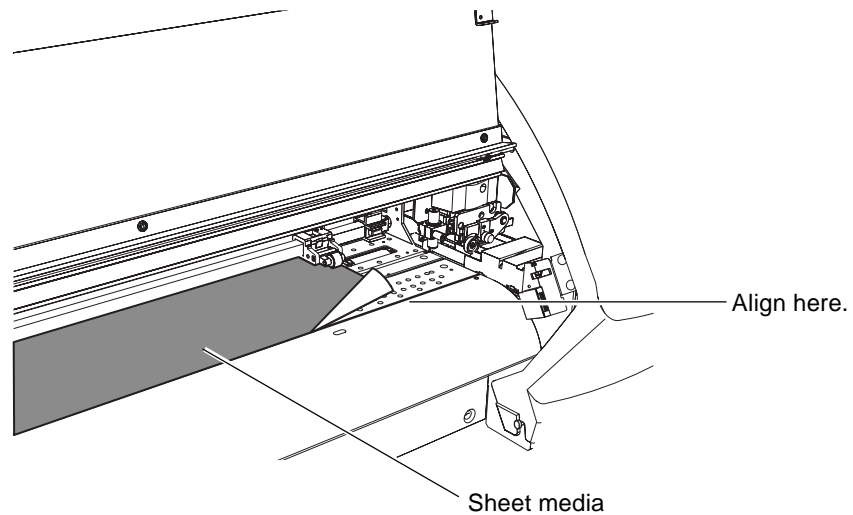

■ Rear View

Remove the shaft and roll media at the back of the unit.

Securing in Place Using the Media Clamps (Only When Printing)

When performing printing, be sure to use the media clamps to secure the media in place. Performing printing without using the media clamps may result in warping of the edges of the media due to thermal expansion or contraction. Warping of the media may result in catching on the printing carriage or other problems that prevent correct printing.

When performing cutting, remove the media clamps. Doing so may damage the equipment.

Types of Media Clamps

There are two types of media clamps. They each have different uses, as described below.

Short Media Clamps

You normally use the short media clamps. (These are installed on the machine when it is shipped from the factory.)

Long Media Clamps

You use these when you want to hold the media in place more securely, such as when you're printing media that warps easily.

The long media clamps interfere with the separating knife. When using them, refer to "Using the Long Media Clamps" on the following page to make the setting so that the media-cutoff operation is not performed.

Notice

When you're using the long media clamps, be sure to make the setting so that the media-cutoff operation is not performed. Failing to make this setting may result in damage to the cutting carriage or the media clamps, or machine malfunction.

Never use any of the following kinds of media, even if it is possible to secure it in place with the media clamps. Attempting to force the use of such media may result in malfunction.

- Media whose warping is not corrected by securing it in place
- Media that deforms the media clamps when it is secured in place
- Media with a strong tendency to curl

Attaching the Media Clamps

Insert firmly into the component on the outside of the pinch roller, until it clicks into place.

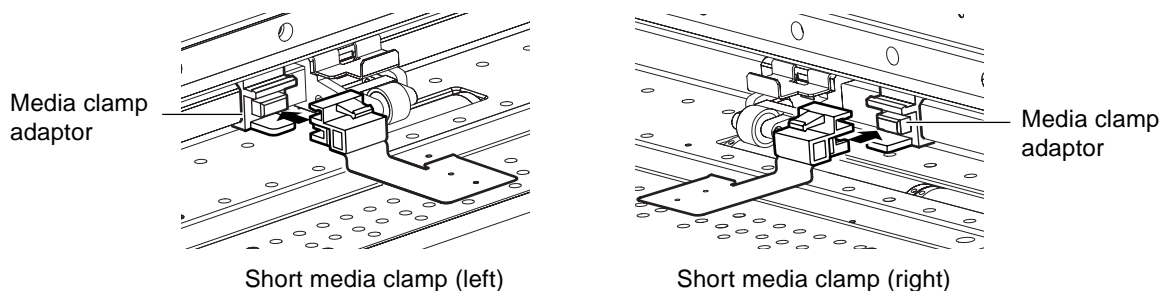

Removing the Media Clamps

While holding down the area shown in the figure, pull back toward you to detach.

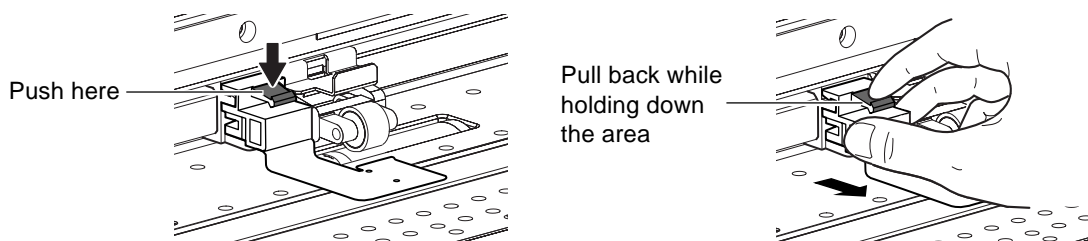

Point

The attachment and detachment methods are the same for both the short and the long media clamps.

You can attach and remove the media clamps even when no media is loaded or when the sheet loading lever is raised.

Using the Long Media Clamps

When you're using the long media clamps, be sure to first make the setting below before you attach the media clamps.

- 1 Press the [MENU] key. Press the [▼] key to select [MEDIA CLAMP].

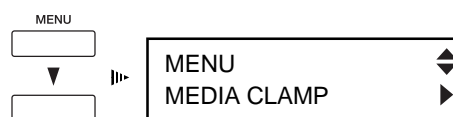

- 2 Press the [▶] key.
The following screen appears.



- 3 Press the [▼] key to select [LONG], then press the [ENTER] key.
The setting is changed.



- 4 Press the [MENU] key.
Go back to the top menu.

Making the setting just described keeps the media-cutoff operation from being executed.

For detailed information about the [MEDIA CLAMP] menu, refer to "6-2 Detailed Descriptions of the Menus."
For more information about media cutoff, refer to "3-3 Separating the Media."

■ Setting the Media Clamps

Line up the holes in the media clamps with the left and right edges of the media.

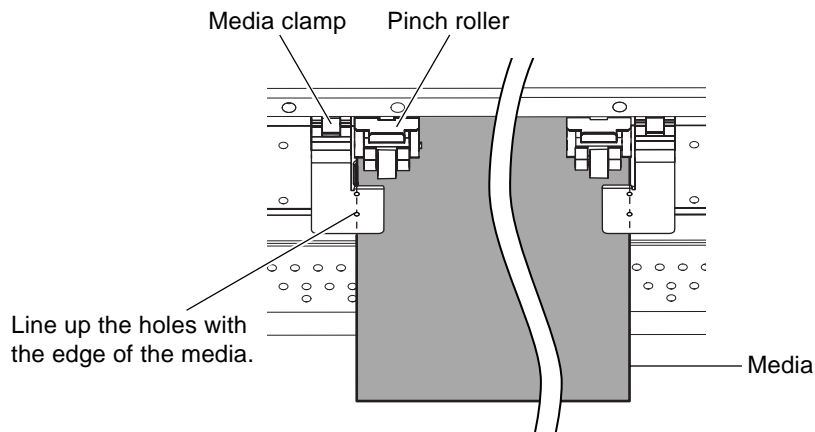

! Notice

Set the media clamps at the correct locations. If they are not set at the correct locations, the media may catch or cause other problems that prevent successful printing.

When you cut off media while using the short media clamps, then depending on the media, it may come loose from the media clamps. After you cut off the media, check to make sure that the media has not come loose from the media clamps.

As printing proceeds, the media may move to the left or right and touch or come loose from the media clamps. After about 1 m (3 ft.) of media has been fed, check the positioning of the media clamps. If the media looks like it may come loose from the media clamps, adjust the positioning of the media clamps.

2-4 Heater Operation

This machine has two types of heaters.

The printing heater warms the media before printing, improving ink adhesion.

The drier warms the media after printing, making the ink dry more rapidly.

When the machine is shipped from the factory, it is set up so that, by default, the heaters run when the sub power is switched on.

When you switch on the sub power, the [HEATER CONFIG] light begins to flash and the heaters start to run.

The heaters run until a preset temperature is reached, then continue to maintain the temperature at the preset level. The [HEATER CONFIG] light is illuminated at this time.

The temperature that is maintained varies as follows, depending on whether media is loaded.

When no media is loaded

The "warm-up temperature," which is lower than the operating temperature, is maintained.

When media is loaded

The temperature preset using the heater configuration menu is maintained.

The [HEATER CONFIG] light flashes while heater temperature is rising, and remains steadily lighted when the preset temperature is reached.

This machine uses automatic control that keeps printing from starting until the heaters reach the preset temperature. You can speed up the wait time until the preset temperature is reached after loading and setting up media by maintaining the warm-up temperature before you load the media.

You can use the [PREHEATING] menu to make the settings for heater operation and warm-up temperature when no media is loaded. For more information, refer to "6-2 Detailed Descriptions of the Menus."

For more information about the heater configuration menu, go to "3-1 Points to Check before Performing Output" and refer to "Making the Temperature Setting for the Heaters."

3. Performing Output

This section describes points to check before you carry out printing or cutting, as well as printing and cutting methods and other matters.

3-1 Points to Check Before Performing Output



Do not touch the platen when the heater is operating.
Doing so may cause burns because the platen is hot.

Before starting printing or cutting, make sure the following points have been carried out.

- Media is loaded and a blade is installed.
- The front cover is closed.
- The [SETUP] light and the [HEATER CONFIG] light are illuminated.

When media setup finishes, the display shows the printable or cuttable width (top menu).

W 550 mm

Top menu

When the top menu appears, check the settings for the following items to ensure that correct printing or cutting is possible.

Making the Temperature Setting for the Heaters

To set the heater temperature, press the [HEATER CONFIG] key then follow the steps below to make the setting.
The printing heater warms the media before printing, improving ink adhesion.
The drier warms the media after printing, making the ink dry more rapidly.



Point

You can set the temperature either to "OFF" or to a value from 35 to 50°C [40 to 122°F] (in steps of 1°C [2°F]). Adjust the temperature to a suitable value matched to the type of media and the ambient environment. In particular, when you're using the machine in a low temperature environment, it may be a good idea to set the preset temperature to a slightly high value.

You can change the setting for the heater temperature even when printing is in progress or when no media is loaded.

If the software you're using is provided with a feature for setting the heater temperature, you can use your software to adjust the temperature. For information on how to do this, refer to the documentation for your software.

- 1 Press the [HEATER CONFIG] key.
The heater configuration menu appears.

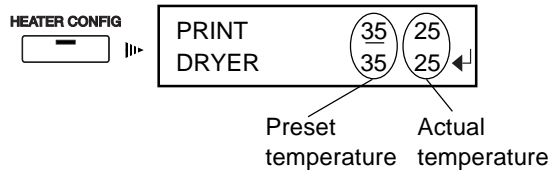

- 2 Press the [▲] and [▼] keys to enter the preset temperature for [PRINT], then press the [ENTER] key.
This enables the preset temperatures for the print heater.

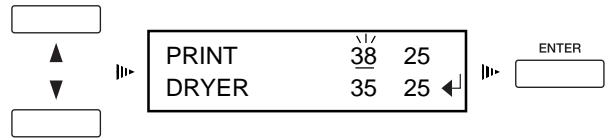

- 3 Press the [▶] key to move the cursor to [DRYER].



- 4 In the same way as in step 2, enter the preset temperature and press the [ENTER] key.
This enables the preset temperatures for the dryer.

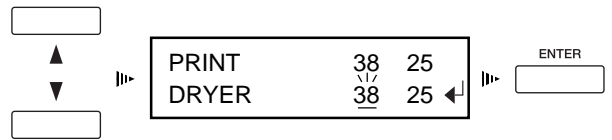

- 5 Press the [HEATER CONFIG] key.
The top menu appears.

Checking the State of the Printing Heads

Before you start to print, carry out a printing test to check the state of the heads. Problems such as missing dots may reduce the printing quality.

If the test results show a problem, carry out head cleaning to restore the heads to their proper state.

- 1 Press and hold the [TEST PRINT] key for at least one second.
The test pattern is printed.

- 2 If dot drop-out is present, clean the heads.
For more information about head cleaning, see "5-2 Cleaning the Printing Heads."

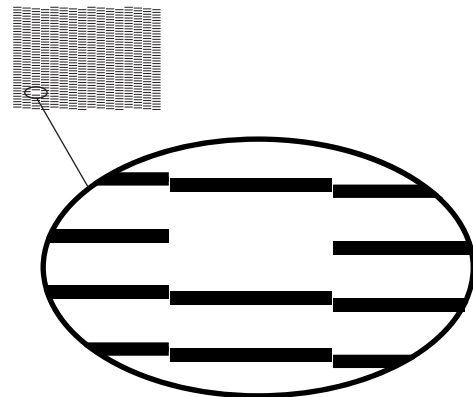

Checking the Cutting Condition Settings

Before you carry out actual cutting, perform a cutting test to check whether the unit performs cutting satisfactorily.

- 1** Install a blade and load media, then close the front cover.
Make sure the [SETUP] light lights up.
- 2** Use the arrow keys to move the cutting carriage to the place where the test cutting is to be performed.
- 3** Press and hold the [TEST CUT] key for one second or longer.
A square and a circle are cut, as shown in the figure.
- 4** Peel off the two shapes and examine the cutting results for the media.

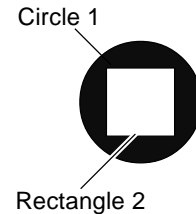

If the two shapes peel off together, or if uncut areas remain, follow the steps below to change the settings for the cutting conditions. For detailed information about verifying the settings for cutting conditions, refer to "4-3 Detailed Descriptions of Cutting Conditions."

Setting Cutting Conditions

Press the [CUT CONFIG] key to display the cutting configuration menu.

- 1** Press the [CUT CONFIG] key.
The following screen appears.
A screenshot of the CUT CONFIG menu. The screen shows "CUT CONFIG" at the top left, followed by a right-pointing arrow and a box containing "FORCE" and "50 gf". To the right of "50 gf" is another right-pointing arrow and "50 gf". On the far right are four arrow keys: left, up, down, and right.
- 2** Use the [◀] and [▶] keys to select the menu item.
A screenshot of the CUT CONFIG menu. The screen shows a left-pointing arrow and a box containing "SPEED". To the right of the box is a right-pointing arrow and "30 cm/s". On the far right are four arrow keys: left, up, down, and right.
- 3** Use the [▲] and [▼] keys to enter the value, then press the [ENTER] key.
The adjustment value is changed

The cutting conditions that you can set using the cutting configuration menu include "blade force," "cutting speed," and the like. For detailed information, refer to "6-2 Detailed Descriptions of the Menus."

Incorrect cutting conditions may cause symptoms such as those described below.

Blade force

- Large
- The media is easily torn during cutting.
 - The blade requires frequent replacement.
 - Cutting extends through the base paper, and normal advancing of the media becomes impossible.
 - The unit suffers damage.
- Small
- Some parts of media remain uncut

Cutting speed

- Fast
- Uncut areas remain in places.
 - The cut depth differs according to the location.
 - The cut shape is distorted.
 - The media is easily torn during cutting.
- Slow
- Cutting takes a long time.

For more information about detailed descriptions of cutting conditions, refer to "4-3 Detailed Descriptions of Cutting Conditions."



Point

Giving Priority to the Cutting Conditions Set on the Machine

When [CUTTING PRIOR] on the machine's display menu has been set to [COMMAND], the program's settings for the cutting conditions take priority. This is set to [COMMAND] by default.

To give priority to the cutting conditions set on the machine, turn off the program settings, or set the [CUTTING PRIOR] menu item to [MENU].

For more information about the [CUTTING PRIOR] menu item, see the section "6-2 Detailed Descriptions of the Menus."

3-2 Performing Output

Notice

Never open the front cover. Opening the front cover while printing or cutting is in progress causes an emergency stop. This means that printing or cutting may not be carried out correctly even if operation is resumed, due to drop-out or misalignment of the image.

The printing heads may be left uncapped (that is, the printing carriage may remain over the platen). If the machine is allowed to stand with the printing heads uncapped for a prolonged period, the printing heads may become irreversibly clogged. If the printing carriage stops while over the platen, press the [POWER] key to reset the power. The printing carriage moves and the printing heads are capped.

If the printing carriage does not move even when you reset the power using the [POWER] key, go to "7-1 What to Do If..." and refer to "What to Do When the Printing Carriage Does Not Move."

During printing, never touch the portion of the media that's already been discharged. Doing so may obstruct media feed or cause the media to rub against the heads, which may result in a paper jam or damage to the heads.

Sending data starts printing or cutting.

You can perform a wide variety of operations depending on the setting for how data is sent.

Sending data only for printing or only for cutting from the computer executes the corresponding printing or cutting only. When data for both printing and cutting is sent, then after printing finishes, cutting starts automatically (Printing & Cutting).

It's also possible to perform operations such as detaching the media after printing, carrying out lamination or the like, then reloading the media and cutting it.

For information on how to make the settings, refer to the documentation for the software you're using.

Point

If the top menu isn't displayed, printing doesn't start even when data is sent from the computer. If another menu screen is displayed, press the corresponding menu key to go back to the top menu.

The important points to note for printing only, for cutting only, and for printing and cutting are different.

When You're Performing Printing Only

In order to perform printing, the heaters must reach the preset temperature. If the heaters have not reached the preset temperature when printing is started, the [HEATER CONFIG] light flashes and the screen shown in the figure appears.

NOW HEATING...

When the heaters reach the preset temperature, the [HEATER CONFIG] light stops flashing and remains continuously lit, and printing starts automatically.

When You're Performing Cutting Only

Notice

When cutting never use media clamps.

If you're using roll media, then before you start cutting, leave media hanging freely at the rear. Turn the media flanges by hand to pull out the necessary length from the roll. If cutting is started without doing this first, a motor error may occur or the roll may fall because the media is pulled with excessive force.

Also, setting the heater temperature to [OFF] may obtain output results that are more stable. For more information about setting the heater temperature, refer to "3-1 Points to Check Before Performing Output."

When You're Performing Printing and Cutting

Allow the Media to Dry Sufficiently Before Starting Cutting

Before you start cutting, allow the media to dry sufficiently. (The required drying time varies according to the type of media.) If the media is not dry enough, the pinch rollers or the blade may smudge the printed surface during cutting. Setting the drying time on the software you're using lets you start cutting after waiting for a fixed interval. For information on how to make this setting, refer to the documentation for the software you're using.

Adjusting the Blade Extension

When you perform printing followed by cutting, the end of the cap for the blade holder may rub against and damage the printed surface. (Damage is even more likely when the media has not been allowed to dry completely.)

If this happens, increase the amount of extension of the blade tip slightly.

For more information about adjusting the blade extension, refer to "4-3 Detailed Descriptions of Cutting Conditions."

3-3 Separating the Media

To cut off a printed portion from the media, use the [SHEET CUT] key.

- 1 Make sure the [SET UP] light lights up.
- 2 Hold down the [SHEET CUT] key for at least one second.
The piece is cut off at the present location of the printing-start line.

SHEET CUT

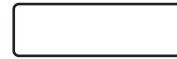

This step is not necessary when cutoff is performed automatically by sending a media-cutoff command from the computer.

Notice

When You're Using the Long Media Clamps

When the long media clamps are attached, they interfere with the separating knife.

When using them, be sure to set the [MEDIA CLAMP] menu item to [LONG] to prevent execution of media cutoff.

When you make this setting, media cutoff is not performed, even if the [SHEET CUT] key is pressed or a media-cutoff command is sent from the computer.

If you want to separate the media after printing has finished, be sure to first detach the long media clamps, then set the [MEDIA CLAMP] menu item to a setting other than [LONG].

For information on how to make the setting, go to "2-3 Loading Media" and refer to "Securing in Place Using the Media Clamps (Only When Printing) -- Using the Long Media Clamps."

For more information about the [MEDIA CLAMP] menu, refer to "6-2 Detailed Descriptions of the Menus."

Point

Depending on the composition of the media, cutoff may not be possible.

Depending on the composition of the media, it may remain on the platen after cutoff. If this happens, remove it by hand.

When you're performing cutoff, never use the [▲] key to pull the media back. Unless the end of the media has been pulled out to a location to the front of the platen, cutoff may not be performed smoothly.

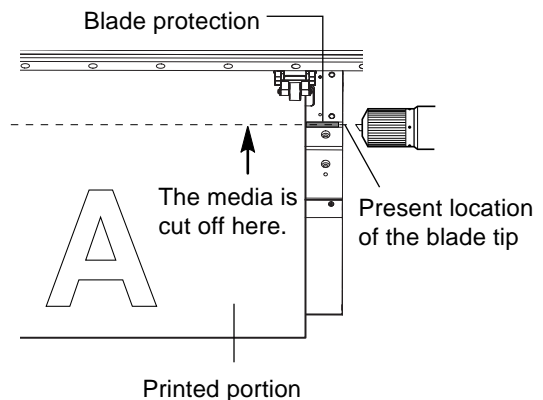

3-4 Stopping or Pausing Output Operations

Use the [PAUSE] key to stop or pause printing or cutting.

Press the [PAUSE] key to pause printing or cutting.
The screen in the figure appears.

TO CANCEL, HOLD
DOWN PAUSE KEY

PAUSE

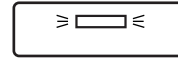

The [PAUSE] light lights up.

After making sure that this screen is on the display, press the [ENTER] key again.
How you press the [PAUSE] key this time determines whether printing or cutting stops or resumes.

Stopping Printing or Cutting

Hold down the [PAUSE] key for one second or longer.
The screen shown in the figure appears and printing is stopped.

CANCELING. . .

Any remaining data is cleared.

To Resume Printing or Cutting

Press the [PAUSE] key again.
Printing or cutting is resumed.

PAUSE



The [PAUSE] light goes out.

4. A wide variety of Operations

This section describes a wide variety of operations and functions, grouped by task.

4-1 Setting the Location Where Output Starts

Set the location where printing or cutting starts at the desired place.

Use the arrow keys and the [BASE POINT] key to set the start points (origin points) for the feed direction (the direction of forward and backward movement) and for the scan direction (the direction of movement of the printing carriage).

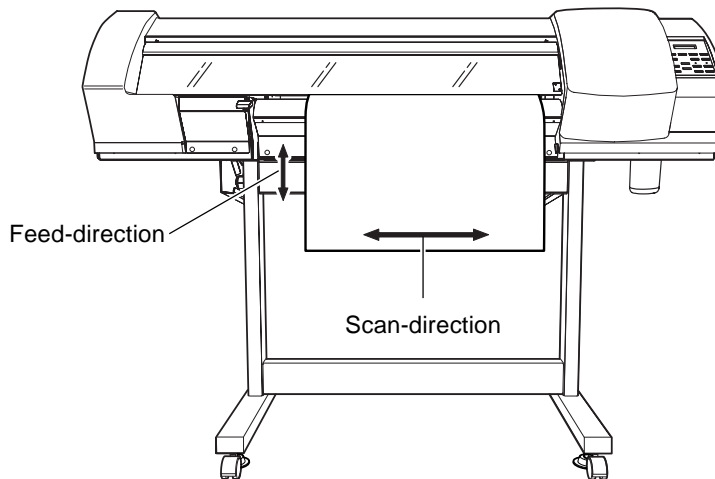
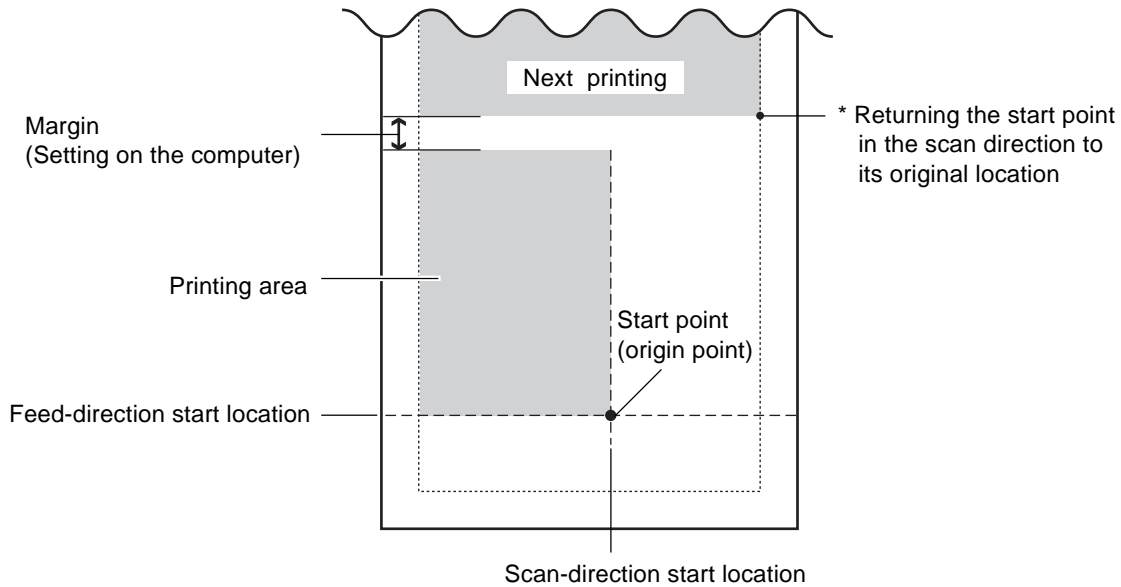

Point

When using the [BASE POINT] key to change the print-start location, then before you set the start position, check the size of the data to print.

Setting the Start Location

- 1 Load media and install a blade.
- 2 Use the arrow keys to align the center of the blade with the new start location for printing or cutting.

The center of the blade



- 3 Press the [BASE POINT] key.
The display shown in the figure appears and the [BASE POINT] lamp is illuminated.

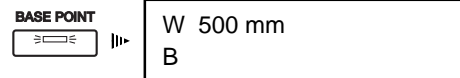

! Notice

When you're performing printing, using the arrow keys to pull back the media should be avoided as much as possible. Doing so may cause the reduce of printing accuracy or sagging printing. Otherwise printing accuracy may reduce or printing may sag.

🔍 Point

When the Start Location Is Specified Using the [▲] [▼] Keys

When the operation is performed using only the [▲] [▼] keys, the cutting carriage comes to a stop inside the cover. Pressing the [BASE POINT] key while in this state sets just the start position for the feed direction (the direction of front-to-back movement). For the scanning direction (the direction of carriage movement), the setting is made at the edge of the printing area.

■ To cancel the setting

The position set using the [BASE POINT] key is canceled in the following situations.

- When printing, cutting, or printing and cutting for one page finish
- When the setup for the media is canceled

4-2 Making Corrections for Printing

When you have replaced the media with media of a different type, or when you're using the machine in a location subject to severe changes in temperature, carry out correction as described below.

Feed Correction

This corrects for errors in the amount of feed of the grit rollers due the type of media. Be sure to make this setting when you have replaced the media with a different type. Correcting the amount of feed improves the dot-positioning accuracy in the feed direction, which can help enhance image quality.



Point

When correcting the amount of feed, make the settings for the same conditions for the type of media used, the configuration of the media (roll media or sheet media), and the heater temperature as when actually performing printing.

When performing test printing for feed correction, load the media correctly (see "2-3 Loading Media"). If the media is not loaded correctly, the results of the printing test may not show accurate adjustment values.

When you can make a setting for error in the amount of feed for the grit rollers on the computer, the computer's setting takes priority. To make the machine's setting take priority, turn off the computer's setting.

Setting the Adjustment Value

- 1 Press the [MENU] key, then press the [▼] key to select [CALIBRATION].

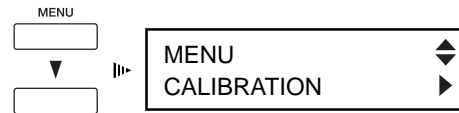

- 2 Press the [▶] key twice, then from the [PRINTING ADJ.] menu, select [TEST PRINT].

The following screen appears on the display.



- 3 Press the [ENTER] key.
A test pattern is printed.



Test Pattern

- 4** Check the printing result. If the correct result is not obtained, then proceed from step 5 and after. Refer to the figure below and modify the adjustment value.

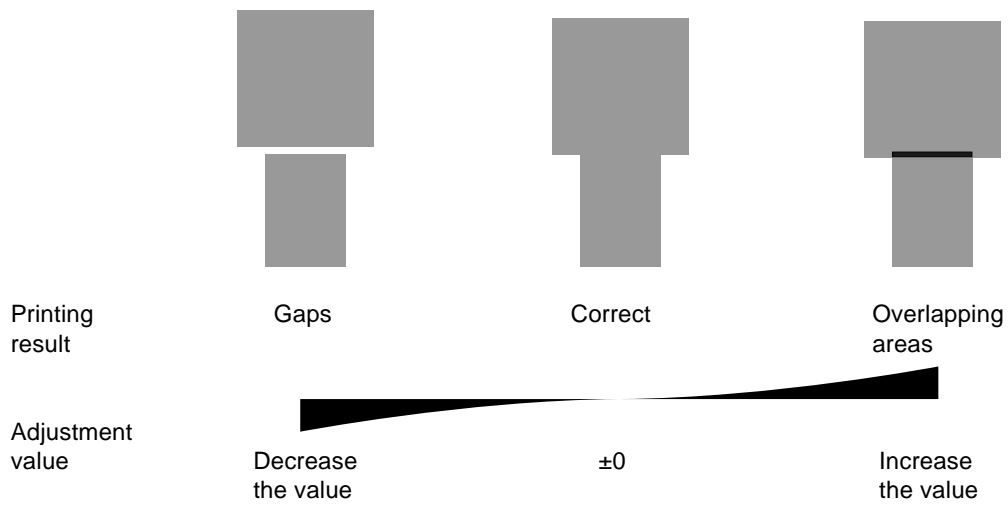

- 5** Press the [▼] key to select [SETTING].



- 6** Press the [▶] key.
The screen shown in the figure appears.

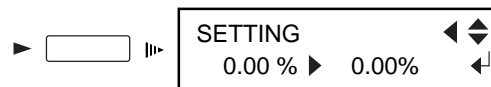

- 7** Use the [▲] and [▼] keys to set the value, then press the [ENTER] key.
The adjustment values are changed.

Bidirectional Correction

This adjusts for misalignment that occurs during bidirectional printing. Perform adjustment for bidirectional correction when media is replaced with a different type or when you're using the machine in a location subject to large changes in temperature.



Point

Bidirectional correction is enabled only when you're performing bidirectional printing.

Setting the Adjustment Value

- 1 Press the [MENU] key, then press the [▼] key to select [ADJUST BI-DIR].

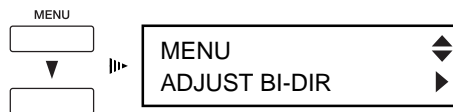

- 2 Press the [▶] key. The screen shown in the figure appears.

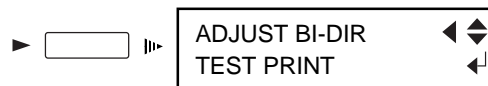

- 3 Press the [ENTER] key. A test pattern is printed. After the printing test has finished, the media is fed to a position that lets you view the test pattern.

- 4 Check the test pattern and select the adjustment value (a value that produces no displacement).

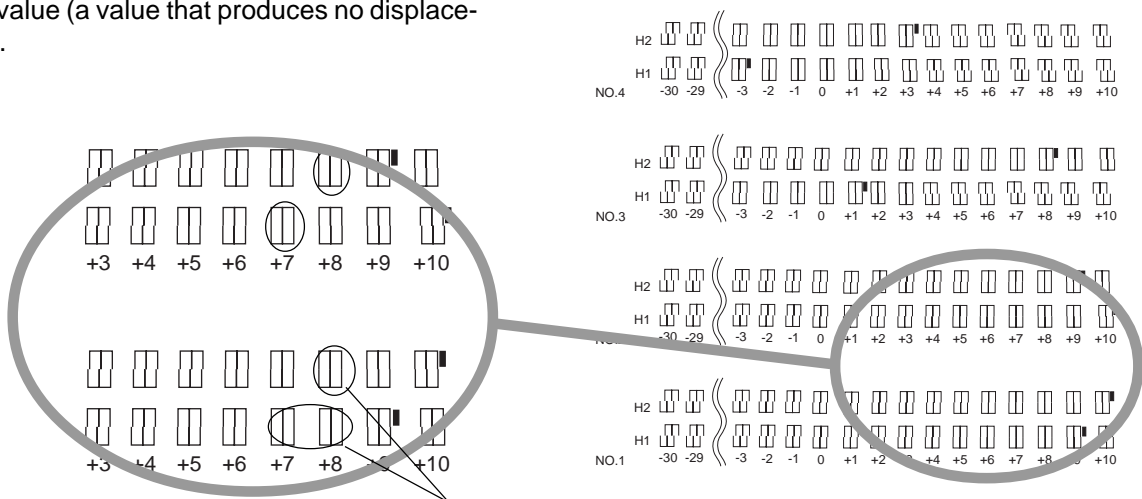

Adjustment value
(The value with no displacement)
In this figure, the No. 1 adjustment values are H1 = 7 1/2 and H2 = 8.

- 5 Check the adjustment value, then press the [ENTER] key.

The media returns to its position where the printing test ended.

- 6** Press the [▼] key to select [SETTING NO. 1].
You can select from [SETTING NO. 1] through [SETTING NO. 4].

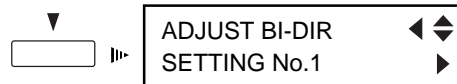

- 7** Press the [▶] key.
The screen shown in the figure appears.

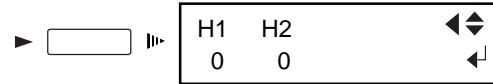

- 8** Use the [◀] and [▶] keys to select H1 or H2.
Use the [▲] and [▼] keys to set the value you checked in step 4.

When you have entered all the adjustment values, press the [ENTER] key.
The adjustment values are changed.

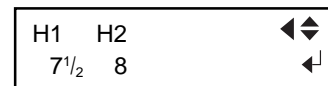

In this case, for [SETTING NO. 1], enter H1 = 7 1/2 and H2 = 8.

- 9** Repeat steps 6 through 8 to enter adjustment values for [SETTING No. 2] through [SETTING NO. 4].

■ Saving and Loading a Bidirectional-correction Value

You can save up to eight patterns of adjustment values for bidirectional correction that you've set in memory. Saving different adjustment values for different types of media lets you load the adjustment value simply and easily when you change the media type.

Saving an Adjustment Value

1 Follow the steps in the previous section, "Setting the Adjustment Value," to enter adjustment values.

2 Press the [▼] key to select [SAVE PRESETTING].

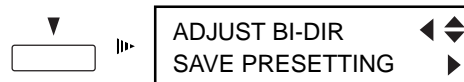

3 Press the [▶] key to display the screen shown in the figure. Select a memory to save to from among [PRESETTING 1] through [PRESETTING 8], then press the [ENTER] key.

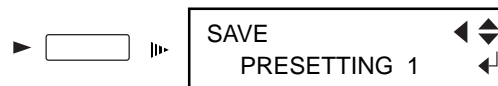

The adjustment values are saved in the memory number you selected.

To select the number, Use [▲] and [▼] keys.

Point

It may be a good idea to keep notes of the memory numbers and the kind of media whose adjustment value is saved in each number.

Loading an Adjustment Value

1 Press the [MENU] key, then press the [▼] key to select [ADJUST BI-DIR].

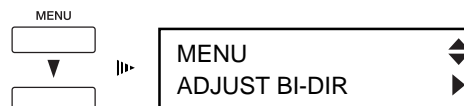

2 Press the [▶] key.
The screen shown in the figure appears.

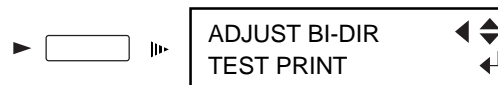

3 Press the [▼] key to select [LOAD PRESETTING].

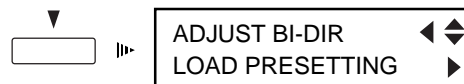

4 Press the [▶] key to display the screen shown in the figure.



Select the memory number to load, then press the [ENTER] key.

The selected adjustment value is loaded.

To select the number, Use [▲] and [▼] keys.

Point

This operation deletes adjustment values that are not saved in memory. If there are adjustment values that you want to keep, save them in memory first.

4-3 Detailed Descriptions of Cutting Conditions

Cutting quality is affected by the blade and media being used, and by the cutting conditions. There are four cutting conditions: cutting speed, blade force, blade offset, and amount of blade extension. For high-quality cutting, it is necessary to set the appropriate cutting conditions for the blade and media in actual use. Repeat cutting tests and adjustments to the cutting conditions until the cutting quality for the media improves.

This section describes how to use the results of cutting tests to check the cutting conditions.

1 Peel off circle 1 (indicated by ●).

- When it can be peeled by itself, without disturbing rectangle 2 (indicated by □), the blade force is set appropriately.
- If it peels, the setting for either the blade force or the amount of blade extension is insufficient.
- If uncut areas remain in some places, the cutting speed is too fast.

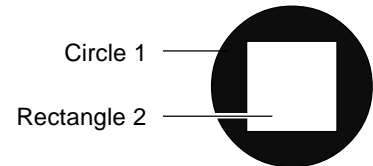

2 Peel off rectangle 2 (indicated by □).

- The optimum blade pressure (blade force) is correct if you can clearly make out the lines left by the blade.
- If the blade trace is indistinct or too strong, you need to adjust the blade force or the amount of blade extension.

3 Check the shape of rectangle 2.

- If the corners are cut fully and properly as shown in A, the conditions are correct.
- If the corners are rounded as shown in B, the setting for blade offset is insufficient.
- If the corners have "horns" as shown in C, the setting for blade offset is too large.
- If the cut shape is distorted, the cutting speed is too fast.

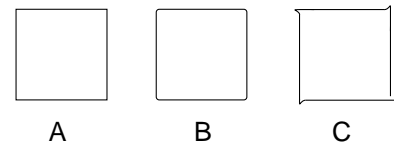

Check the points described above, and if the cutting quality of the media is less than good, adjust the cutting conditions. For information on how to perform a cutting test and adjust the cutting conditions, go to "3-1 Points to Check Before Performing Output" and refer to "Checking the Cutting Condition Settings," and refer also to "6-2 Detailed Descriptions of the Menu."

Adjusting the Blade Extension

When you want to perform accurate and fine adjustment of the cutting-in amount, such as when cutting media with thin carrier paper, you can obtain good results by adjusting the tip of the blade. Turn the cap portion of the blade holder to adjust the amount of blade extension.

A change in extension of 0.5 mm can be made by rotating the cap one full turn.

Note that making the amount of blade extension too small may cause the end of the cap for the blade holder to touch and damage the printed surface. It's important to be especially careful about this when you're using media that has poor ink-adhesion properties.

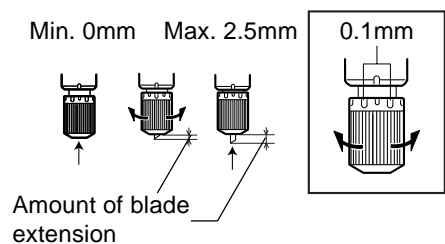

Point

Rough Estimate for the Amount of Blade Extension

Use the following dimension as a rough estimate for setting the amount of blade extension.

$$\text{Amount of blade extension} = \text{Thickness of the media portion} + \frac{\text{Thickness of the carrier paper}}{2}$$

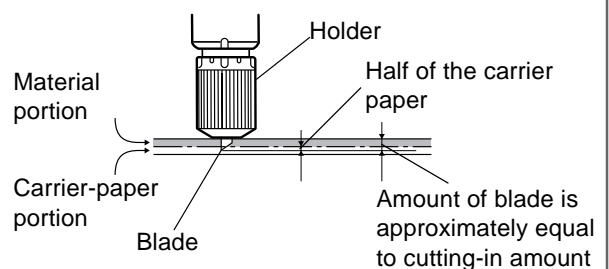

4-4 Making Corrections for Printing and Cutting

If the locations of printing and cutting become misaligned, you use the [PRINT-CUT ADJ.] menu item to perform position alignment.

Adjusting Automatically

- 1 Load a media.
Make sure the [SET UP] light is illuminated.

- 2 Go to "1-3 Assembling and Installing" and refer to "Step 8: Match the Machine to the Environment Where Installed" to execute [ENV. MATCH].



- 3 After finishing, press the [▼] key to select [PRINT-CUT ADJ.].

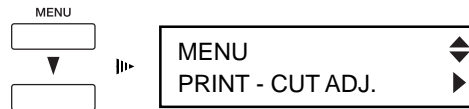

- 4 Press the [▶] key.
The screen shown in the figure appears.

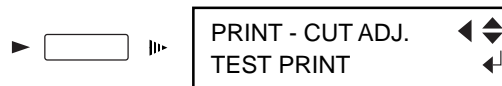

- 5 Press the [▲] key to select [AUTO].



- 6 Press the [ENTER] key to print a square mark and read it automatically.

Position alignment starts. Printing and reading of the square marks is performed automatically. When the operation has finished the screen shown in the figure appears.

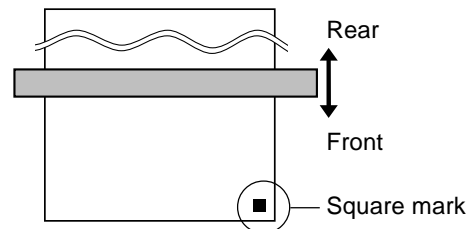
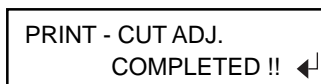

- 7 Press the [ENTER] key.
The display returns to the screen in step 4.

Point

Depending on the type of media, it may not be possible to perform correction automatically. If this happens, read in the offset value from a test pattern and align the positions for printing and cutting. For information on how to read an offset value from a test pattern, see the next section, "Adjusting Manually."

Adjusting Manually

Read the adjustment value from the test pattern printed and cut on the media. Enter the read adjustment value with the operation panel, then align the printing and cutting positions.

- 1 Load media and install a blade.
Make sure the [SET UP] light is illuminated.

- 2 Go to "Adjusting Automatically" on the previous page and carry out steps 2 through 4.
The screen shown in the figure appears.

- 3 Press the [ENTER] key.
Printing and cutting a test pattern are performed.

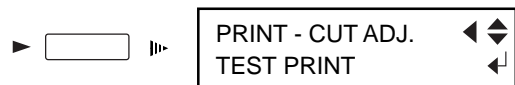

- 4 From the test pattern, read the value at the location shown in the figure.

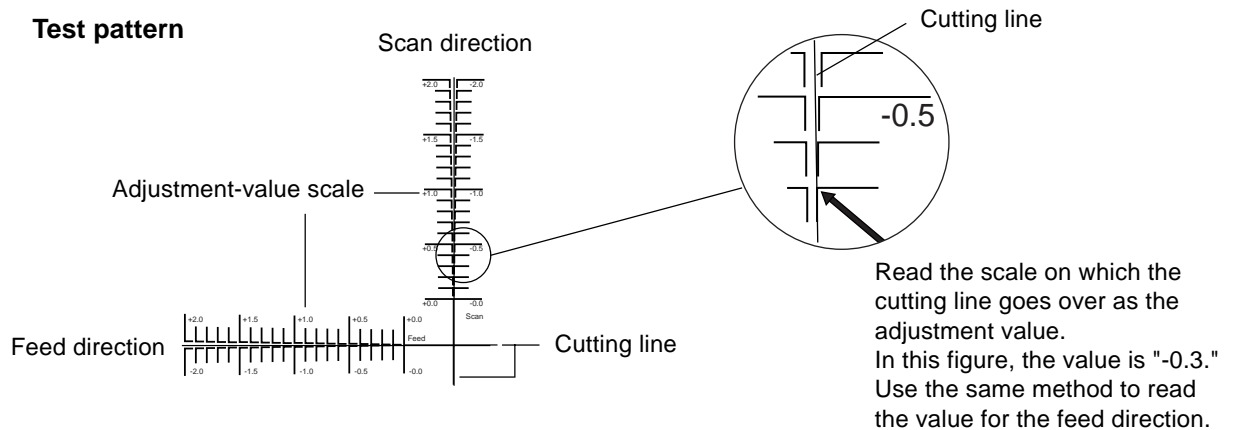

- 5 Press the [▼] key to select [FEED SETTING].

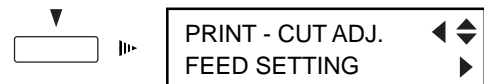

- 6 Press the [▶] key.
The screen shown in the figure appears.

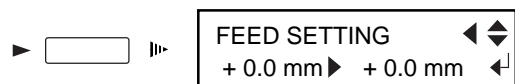

- 7 Press the [▲] and [▼] keys to enter the feed-direction adjustment value read in step 5, then press the [ENTER] key.

- 8 Repeat steps 6 through 8 and enter the adjustment value for [SCAN SETTING].

4-5 Reloading the Media and Performing Cutting

When you are performing printing, then performing lamination or the like, reloading the media, and performing cutting, using the alignment function makes it possible to align the printing and cutting positions. Alignment of the printing and cutting positions uses crop marks. Printing with crop marks added enables automatic detection of the crop marks during cutting, thereby making alignment possible.

Printing with Crop Marks

Load media and output the data. Crop marks are automatically printed at four places. Use your software to make the setting for printing crop marks. For information on how to make the setting, refer to the documentation for the software you're using.

You can use BASE POINT and ALIGN POINT 1 through ALIGN POINT 3 to perform alignment automatically or manually. For information about how to make the settings, see the following section.

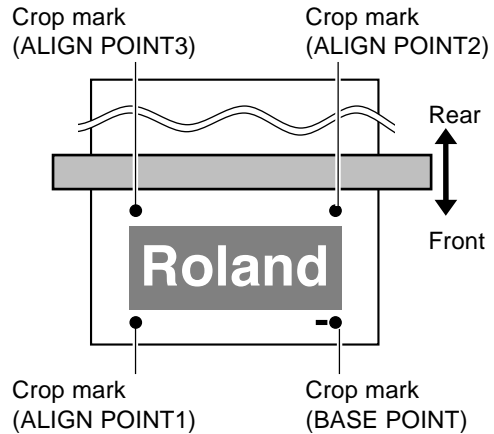

Point

Crop marks and the like drawn with computer programs cannot be used as crop marks by this machine.

Media Sizes Allowing Automatic Crop-mark Detection

When you are printing with crop marks, set a margin of at least 90 mm (3-9/16 in.) before the next print-start position. You can set the margin value with the software you're using. For information on how to make the setting, refer to the documentation for the software you're using.

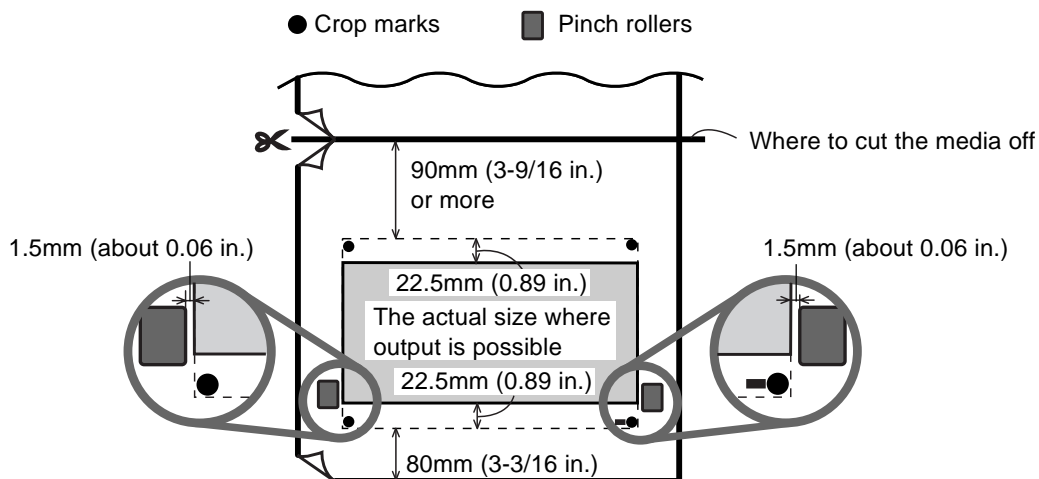

Aligning Automatically

When you make the setting for reading crop marks when sending cutting data from the computer, alignment is performed with the presence or absence of crop marks determined automatically. For information on how to make the setting, refer to the documentation for the software you're using.

- 1 Align the crop marks with the blade protector and load a media.

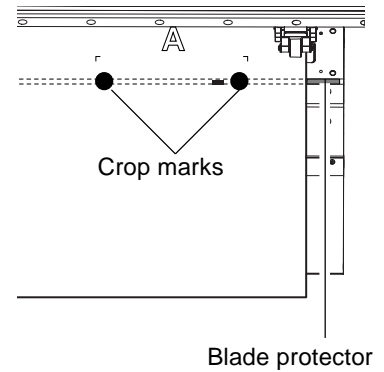
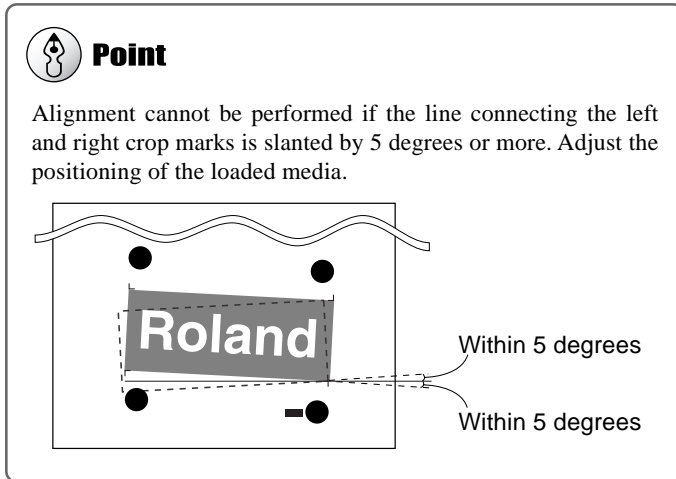

- 2 When you send data, alignment is performed automatically, then cutting starts.

 **Point**

If Automatic Alignment Cannot Be Performed

If the machine fails to detect the crop marks, the screen shown at right appears and operation stops.

If this happens, press the [ENTER] key, then take action as follows.

- (a) The media is slanted at too great an angle, or its loaded location is misaligned.
Try redoing steps 1 and 2 described above.
- (b) The media may not be suitable for automatic crop-mark detection.
Perform alignment manually.

Lengthy media is prone to large error due to warping and the like, making it unsuited to cutting alignment. We recommend dividing the image data into segments that are as short as possible, then performing output separately for each segment. To perform alignment by hand, refer to the next section, "Aligning Manually."

To Stop Detection

To stop crop-mark detection while in progress, follow the steps below.

1. Press the [PAUSE] key. The screen shown in the figure appears.
2. Press the [ENTER] key.



Aligning Manually

Depending on the type of media, it may not be possible to detect crop marks automatically. When crop marks cannot be detected automatically, you perform alignment manually.

- 1 Set the location of the origin point. Use the arrow keys to move the center of the blade to the position above the lower-right crop mark.

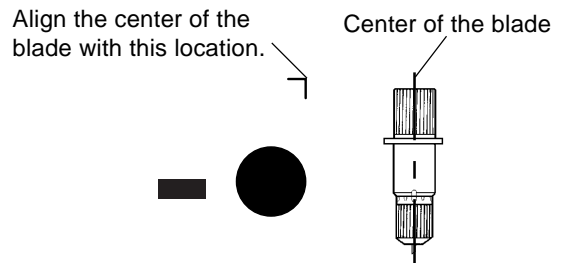

- 2 Press the [BASE POINT] key.
The [BASE POINT] light lights up.
The location where the BASE POINT is set is displayed.

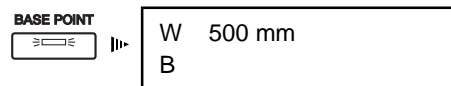

- 3 Use the arrow keys to align the center of the blade with any of the align points (ALIGN POINT 1 through ALIGN POINT 3), then press and hold the [BASE POINT] key for one second or longer.

Align the center of the blade with this location.



- 4 When the screen shown in the figure appears, press the [ENTER] key.
The align point is set.

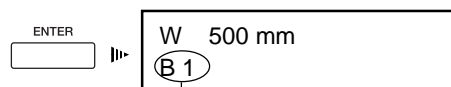
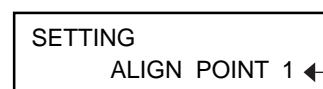

This screen shows BASE POINT and ALIGN POINT 1 are set.

Point

You can make settings for up to three align points. Change the number of points set with [ALIGN POINT] as required.

The locations on the media of ALIGN POINT 1 through ALIGN POINT 3 are fixed. The machine automatically determines from the location of the BASE POINT setting which align point or points have been set. The screen display the number of each align point that has been set. For information about the location of align points, see the previous section, "Printing with Crop Marks."

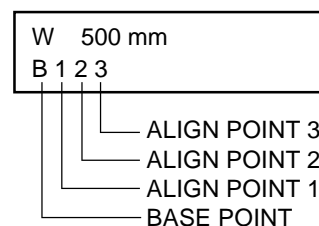

The ALIGN POINT settings cannot be made unless the BASE POINT has been set. Setting the BASE POINT after setting ALIGN POINTs clears all the previously set ALIGN POINTs.

4-6 Checking the Remaining Ink Level

You can use the [INK REMAINING] menu item to check how much ink is left after the ink cartridges have been installed. Use this information as a guide for replacing the ink cartridges.

For more information about using and replacing ink cartridges, refer to "5-1 Replacing the Ink Cartridges."



Point

In situations such as the following, the actual amount of ink remaining is not displayed.

- When a partly used ink cartridge is removed and reinstalled
- When a partly used ink cartridge is installed

The installed ink cartridge is taken to be an unused cartridge and the default amount of remaining ink is displayed.

- 1** Press the [MENU] key, then press the [▼] key to select [INK REMAINING].

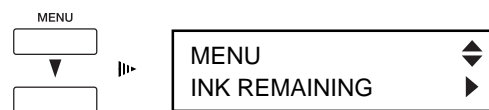

- 2** Press the [▶] key.

The amount of remaining ink for all ink cartridges appears on the display. The numerals on the display indicate the numbers on the labels for the ink-cartridge ports. The figure shows that little ink remains for No. 3 (magenta).

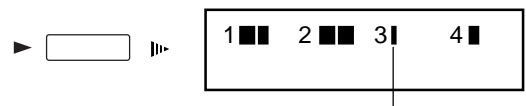

The fewer the markers, the less is the amount of ink left.

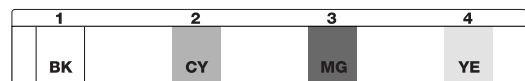

Ink-cartridge port label

- 3** After checking, press the [MENU] key to return to the top menu.

4-7 When Not in Use for a Prolonged Period

When the machine will remain unused for an extended period, we recommend switching off only the sub power and leaving the main power on.

About once a month a warning beep sounds to prompt cleaning as indicated below.

- 1 When the machine remains unused for about a month, a warning beep sounds and the following message appears on the display.

PRESS THE POWER
KEY TO CLEAN

- 2 Press the [POWER] key to switch on the sub power.
Cleaning is performed automatically.



The [POWER] light
lights up.

- 3 After cleaning has finished, hold down the [POWER] key for one second or longer to switch off the sub power.

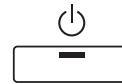

The [POWER] light
goes out.

Switch on the power at least once a month, even when the main power is switched off. Switching on the sub power automatically performs cleaning.

Notice

Even when the machine is not in use, keep it in an environment where the temperature is 5 to 40°C (41 to 104°F) and the humidity is 20 to 80% (with no condensation). Be especially careful not to expose the machine to high temperatures of 40°C (104°F) or more.

5. Maintenance

This section describes replacement of the ink cartridge, cleaning for the printing heads, daily care and maintenance, and the like.

5-1 Replacing the Ink Cartridges

If ink runs out, replace the ink cartridges.

Be sure to use genuine ECO-SOL INK cartridges from Roland DG Corp.

Care and Handling of Ink Cartridges

Give attention to the following points when handling ink cartridges.

Notice

Never attempt to disassemble.

Never drop or allow to fall. The impact from a fall may cause damage, making the cartridge unusable.

Store unopened in a well-ventilated location where the temperature is from -20°C (-40°F) to 40°C (104°F).

Once an ink cartridge has been installed, never remove it until the ink has been used up, except when moving the machine. Frequent insertion and removal may cause air to enter the ink tube, resulting in dot drop-out or other problems in printing quality.

Replacing with New Ink Cartridges

Before you attempt to replace an ink cartridge, check the following points.

- The machine is switched on.
- Operation is stopped or paused.

Also, always be sure to gently shake the ink cartridge before you install it. Installing it without shaking it first may result in unstable colors during printing.

Notice

Removing or inserting an ink cartridge while operation is in progress may cause air to get inside the cartridge, resulting in poor image quality.

Never attempt to install any ink other than an ECO-SOL INK cartridge. Doing so may result in malfunction or faulty operation.

After removing an ink cartridge, never allow the machine to stand with the ink-cartridge port remaining empty -- install a new ink cartridge immediately. Failure to do so may result in clogging of the heads.

Replacing an Ink Cartridge

- 1 Remove the ink cartridge from the ink-cartridge port.

Notice

Remove an ink cartridge gently. Sudden movement when removing may cause ink to be spilled.

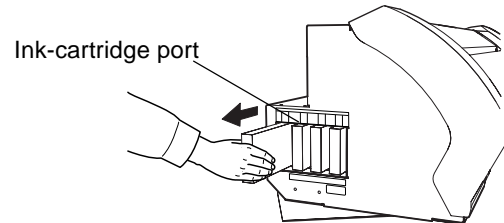

- 2 Gently shake the new ink cartridge, then insert it slowly.

If Ink Runs Out During Printing

If ink runs out during printing, a warning beep sounds and the screen shown in the figure appears. Replace the ink cartridge. Ignoring the message and continuing printing without replacing the ink may adversely affect image quality, resulting in faintness or other problems.

When a cartridge runs out of ink, its number and "_" flash.

Replacing Ink (When Set to the [STOP] Mode)

- 1 Pull out the ink cartridge indicated by the flashing number on the display.
- 2 Gently shake the new ink cartridge, then insert it slowly.

Point

The behavior that occurs when it becomes necessary to replace ink while printing is in progress differs according to whether the selection for [EMPTY MODE] under [INK CONTROL] is set to [CONT.] or to [STOP]. (The default setting is [STOP].)

When Set to [STOP] (Pause)

[STOP] causes operation to pause immediately when ink needs to be replaced. Printing is resumed by replacing the cartridge. Note, however, that colors of an image in progress may no longer match perfectly. Before you perform lengthy printing, replace with ink cartridges that contain enough ink.

When Set to [CONT.] (Continue Printing)

Select this when ink cannot be replaced immediately while printing is in progress, such as during unattended operation at night. When the machine is set to [CONT.], an alarm sounds approximately 1 m² before ink runs out, but printing continues without pausing. Because printing continues with only a small amount of remaining ink, the printed ink may be faint. As a general guide, about 1 m² of printing is possible with the remaining ink, but the amount of ink used varies greatly depending on the image. Printing can be continued only for the data for which printing is currently in progress. The machine stops when it finishes outputting one image.

5-2 Cleaning the Printing Heads

Switching on the sub power automatically performs maintenance operations, including cleaning of the printing heads. This means that there is normally no need to perform cleaning otherwise. If drop-out occurs with printed images, clean the printing heads.

Notice

Perform head cleaning only when there is dot drop-out (gaps) or printing becomes faint. Performing head cleaning more than necessary subjects the heads to wear and consumes ink. In particular, cleaning performed using the [POWERFUL] menu setting for [HEAD CLEANING] can cause premature head wear and consume large amounts of ink. (Performing cleaning at the [POWERFUL] setting consumes approximately 30 cc of ink for all ink cartridges.)

Cleaning the Printing Heads

If drop-out occurs with printed images, you first use the [CLEANING] key to perform cleaning.

1 Load media for printing-test use.

2 Hold down the [CLEANING] key for at least one second.

Cleaning of printing heads starts.



3 After head cleaning has ended, hold down the [TEST PRINT] key for one second or longer.

The test pattern is printed.



4 Go to "3-1 Points to Check Before Performing Output" and refer to "Checking the State of the Printing Heads" and check the printing-test results. If a problem is found, repeat the cleaning.

If performing cleaning several times does not correct the image drop-out problem, perform head cleaning by selecting the [HEAD CLEANING] menu from the main menu. For more information, refer to "If Drop-out Persists Even After Carrying Out Cleaning Several Times" on the next page.

If Drop-out Persists Even After Carrying Out Cleaning Several Times

If drop-out persists even after carrying out cleaning several times, follow the steps below to perform head cleaning.

1 Load media for printing-test use.

2 Press the [MENU] key, then press the [▼] key to select [HEAD CLEANING].

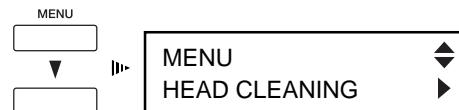

3 Press the [▶] key, then press the [▼] key to select [POWERFUL] or [MEDIUM].

Press the [ENTER] key.

Head cleaning starts.

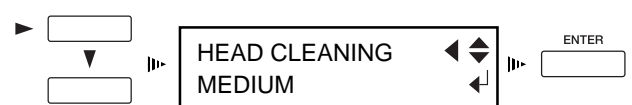

4 When head cleaning finishes, perform a printing test to check the result.



Point

If Performing Powerful Cleaning Several Times Does Not Correct the Drop-out Problem

If performing cleaning several times at the [POWERFUL] menu setting does not correct the image drop-out problem, then perform cleaning using the included cleaning kit. For information on how to use the cleaning kit, refer to the following section, "Cleaning Using the Cleaning Kit."

Cleaning Using the Cleaning Kit

Cleaning using the cleaning kit should be carried out when automatic cleaning and forced cleaning performed using the [HEAD CLEANING] menu item fail to correct image drop-out. It removes any ink buildup and accumulated dust or grime from around the printing heads, as these can cause image drop-out or ink drips. We also recommend performing periodic cleaning using the cleaning kit to prevent problems like these during printing.

If image drop-out persists even after performing cleaning with the cleaning kit, or if the cleaning kit has been used up, contact your authorized Roland DG Corp. dealer or Roland DG Corp. service center.

The heads are consumable parts. The useful life is six billion shots per nozzle.

Notice

Before you attempt cleaning, read through this section carefully to familiarize yourself with the procedures, then carry out the cleaning operations quickly and accurately.

Cleaning is performed while the caps on the printing heads are detached, so cleaning must be completed before the heads dry out. It is suggested that cleaning be completed in thirty minutes or less.

If it appears that cleaning operations may take more than thirty minutes, stop the cleaning operations and follow the steps below.

1. Attach the cover for the right side of the machine.
2. Press the [ENTER] key. (Cleaning of the printing heads starts.)
3. Again carry out cleaning using the cleaning kit.

Before Starting Cleaning

- 1 Switch on the main power switch on the back of the machine.
Leave media unloaded at this time.

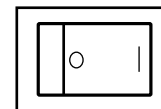

Switch to the "I" side.

- 2 While holding down the [CLEANING] key, switch on the [POWER] key.
The screen in the figure appears.



- 3 Select [CLEANING], then press the [ENTER] key.
The screen in the figure appears.

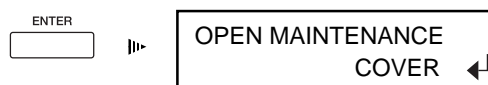

- 4** Open the front cover and detach the maintenance cover.

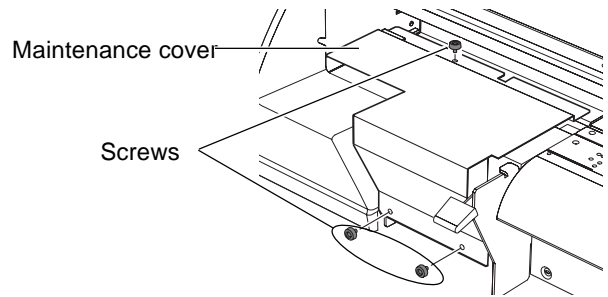

- 5** Close the front cover, then press the [ENTER] key.
The printing carriage moves, and the screen shown in the figure appears.

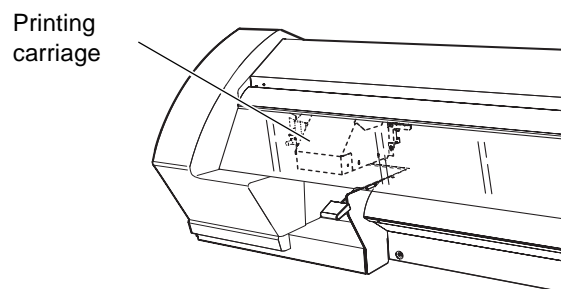
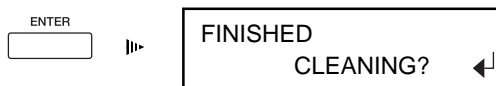

- 6** Open the front cover, then remove the two screws and the cover.
Lift the cover up and remove it.

! Notice
Take care not to drop the cover when removing it. If dropped, the impact may cause it to break.

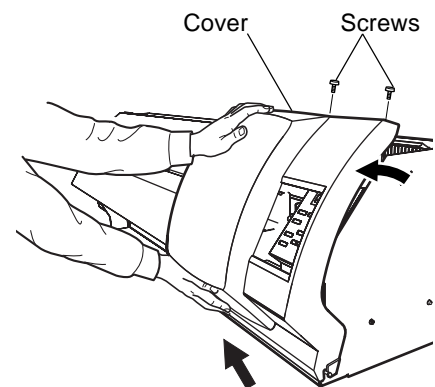

- 7** To discharge static electricity from your body, touch the location shown in the figure.

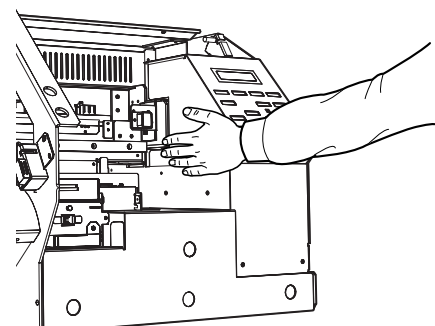

Cleaning Using the Cleaning Kit

- 1 Clean the heads and the area around the heads on the left side of the machine. Use a cleaning stick to wipe off any grime from the stainless-steel frame for the heads and the plastic areas on either side of the heads.

! Notice

Be sure to use one of the included cleaning sticks. Never touch the nozzle surface of the heads.

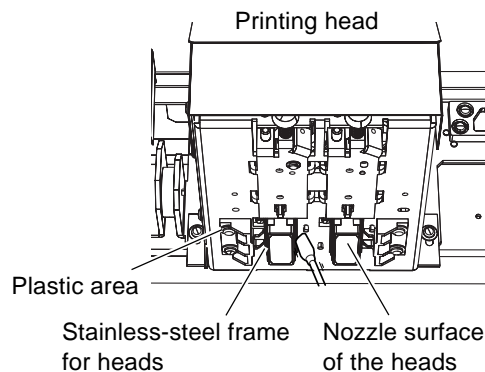

- 2 Clean the surface of the stainless-steel frame on the right side of the machine. Use a cleaning stick to wipe away any buildup of dust and ink from the surface of the stainless-steel frame.

! Point

Give special attention to removing the fibrous dust that tends to build up on the heads.

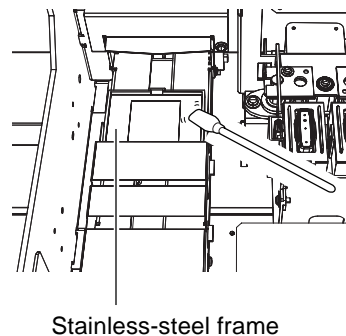

- 3 Clean the rubber caps and the area around them. Use a cleaning stick to wipe off any buildup of dust or grime from the rubber caps. If dust is present on the sponges, wipe it off with the cleaning stick.

! Notice

If no grime is present, never touch the sponges inside the rubber caps.

When removing grime adhering to the sponge inside a rubber cap, touch the sponge gently with the tip of the cleaning stick to pick up the grime. Rubbing forcefully may damage the surface of the sponge.

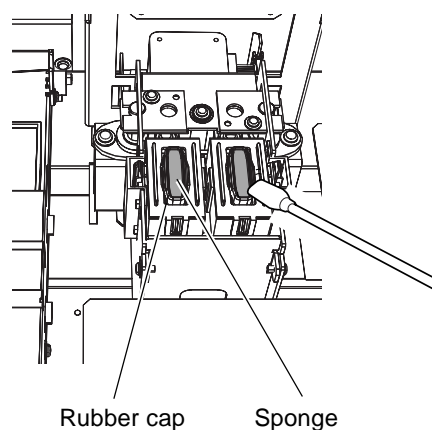

- 4** Clean the wiper.
Use the [▼] key to extract the wiper.

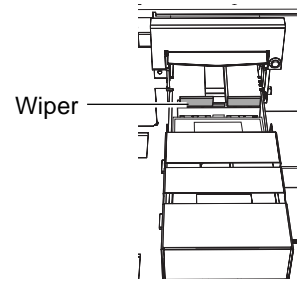

- 5** Use a cleaning stick to wipe away any buildup of dust and grime from the wiper.



Point

Replacing the Wiper

If the message [REPLACE WIPER] appears on the display, replace the wiper with a new one. As a rule of thumb, the message prompting you to replace the wiper appears when cleaning has been performed 1500 times.

For information on how to replace the wiper, refer to "5-4 Replacing the Consumable Parts," the section "Replacing the Wiper."

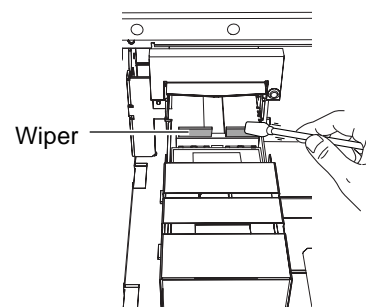

After Finishing Cleaning

- 1 Attach the cover of the machine, then close the front cover.

Engage the cover on the hooks to install.

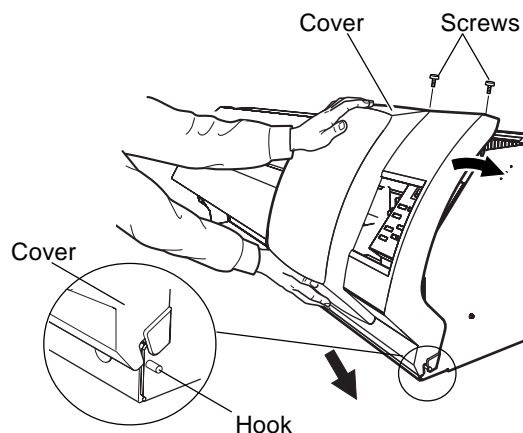

- 2 Press the [ENTER] key.

The screen in the figure appears.

The printing heads return to the standby position, and head cleaning starts automatically.

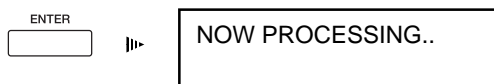

- 3 Make sure the screen in the figure appears on the display, then open the front cover and attach the maintenance cover.

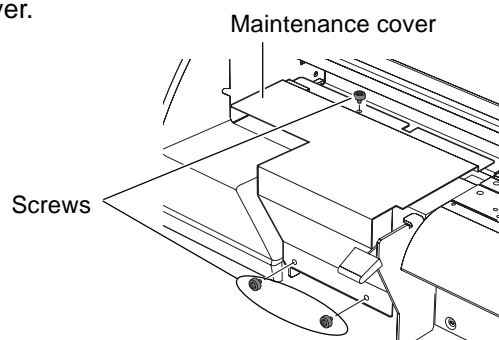
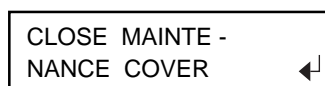

- 4 Close the front cover and press the [ENTER] key.

The sub power is switched off.

- 5 Again press the [POWER] key to switch on the sub power.

- 6 Load media and carry out a printing test.

Examine the results of the printing test and make sure that all dots are printed attractively. If necessary, perform head cleaning to make the dots clean and even.

5-3 Other Cleaning Tasks

The machine and the inside of the front cover may become soiled with ink during printing. The cleaning methods described below let you continue printing without affecting the printed media or the machine.

Notice

When carrying out any cleaning other than cleaning using cleaning sticks, switch off the main power.

* Before turning off the main power, press the [POWER] key to switch off the sub power.

Never lubricate the mechanisms.

Never clean with solvents (such as benzine or thinners).

Periodically clean the platen, grit rollers, and media clamps.

Never touch the printing heads or allow the printing heads to come in contact with anything except ink.

Cleaning the Body

Use a cloth moistened with water then wrung well, and wipe gently to clean. Wipe the operation panel and display gently with a clean, soft cloth.

Cleaning the Platen

Moisten a cloth with neutral detergent diluted with water, wring dry, and wipe gently.

For buildup of cutting dust on the platen, use a commercially available brush to brush away the buildup toward the front.

When doing this, never use a metal brush.

Cleaning the Grit Rollers

Use a commercially available brush to remove dust and other detritus.

Any adhering grime may prevent the media from being held in place securely.

Cleaning the Pinch Rollers

Moisten a cloth with neutral detergent diluted with water, wring dry, and wipe gently.

Cleaning the Front Cover

Use a cloth moistened with water then wrung well, and wipe gently to clean.

Cleaning the Media Clamps

If there is buildup of ink or dust, moisten a cloth with neutral detergent diluted with water, wring dry, and gently wipe the surface.

5-4 Replacing the Consumable parts

Replacing the Wiper

If the screen shown in the figure appears, replace the wiper with a new one.

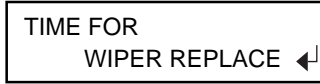

- 1 Follow steps 1 through 2 in "5-2 Cleaning Using the Cleaning Kit -- Before Starting Cleaning" to go to the maintenance menu. Press the [▼] key to select [WIPER REPLACE], then press the [ENTER] key.

The printing carriage moves to a position above the platen.



- 2 Follow steps 6 and 7 in "5-2 Cleaning Using the Cleaning Kit -- Before Starting Cleaning" to detach the right cover and discharge static electricity from your body.

- 3 Attach the stoppers at the locations shown in the figure.

Make sure the following screen appears.
For the stopper, use a cleaning stick or the like.

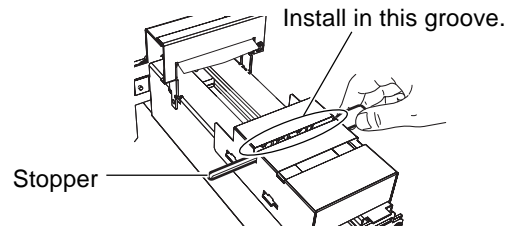
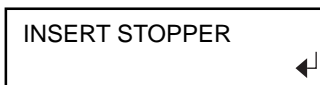

- 4 Press the [ENTER] key.

The wiper moves.

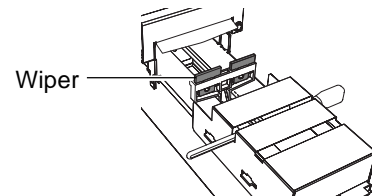

- 5 Using tweezers, grasp the bottom portion of the wiper and take it off the hook.

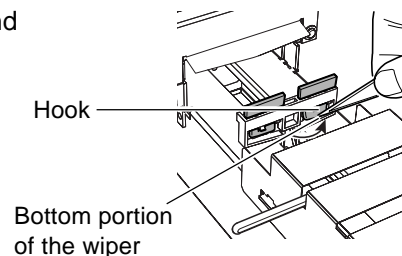

- 6 Remove the wiper and install the new one.



Point

The wiper has a rubber surface and a felt surface. Attach the wiper so that the rubber surface faces the front.

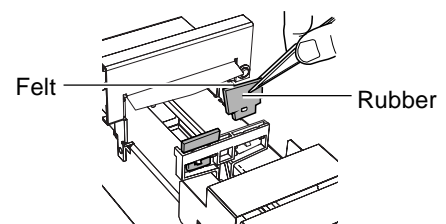

- 7** Use the tweezers to press the area shown in the figure and engage the wiper on the hook.

! Notice

When installing the wiper, be sure to engage it on the hook. If the wiper is not hooked, it may fall off during use.

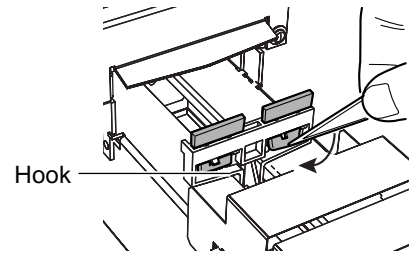

- 8** Make sure the screen shown in the figure is displayed, then remove the stopper you attached in step 3.

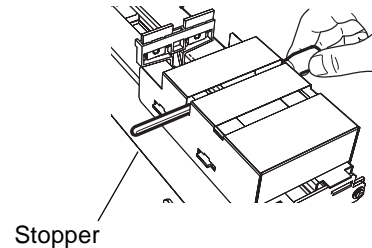

- 9** Follow step 1 in "5-2 Cleaning Using the Cleaning Kit -- After Finishing Cleaning" to attach the right cover of the machine.

- 10** Press the [ENTER] key.

The screen shown in the figure appears, the printing heads return to the standby position, and head cleaning starts automatically.

After cleaning has finished, switch off the sub power.

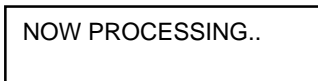

- 11** Press the [POWER] key to switch on the sub power.

- 12** Load media and carry out a printing test.

Examine the results of the printing test and make sure that all dots are printed attractively. If necessary, perform head cleaning to make the dots clean and even.

Replacing the Ink-Absorbing Material

If the screen shown in the figure appears, replace the ink-absorbing material with a new one.

Point

Wear gloves when replacing the ink-absorbing material.

If any ink gets on your hands or clothing, wash it off as soon as possible.

Dispose of used absorbent material in accordance with your local laws.

- 1 Switch off the sub power and the main power.
- 2 Follow steps 6 in "5-2 Cleaning Using the Cleaning Kit -- Before Starting Cleaning" to detach the right cover.

- 3 Pull out the discharged-ink tray and replace the absorbent material.

- 4 Secure the discharged-ink tray in place and re-attach the cover and follow step 1 in "5-2 Cleaning Using the Cleaning Kit -- After Finishing Cleaning" to attach the right cover of the machine.

- 5 Switch on the main power and the sub power.
The screen shown in the figure appears.

- 6 Press the [ENTER] key.

TIME FOR
SPONGE REPLACE ◀

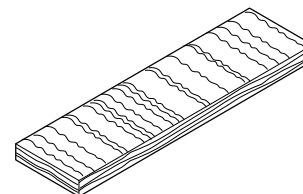

Ink-absorbing material

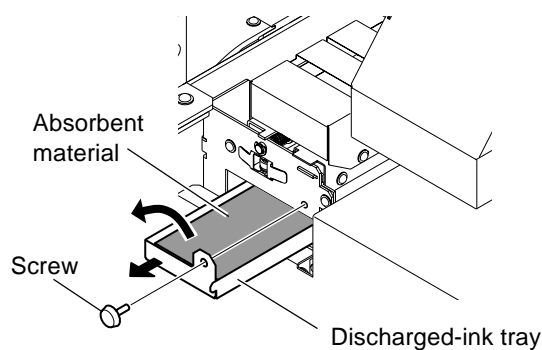
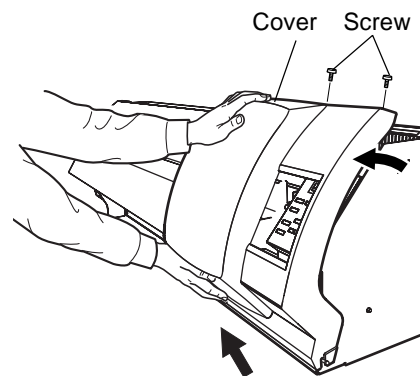

TIME FOR
SPONGE REPLACE ◀

How to Replace the Blade

 Do not touch the tip of the blade with your fingers. Doing so may result in injury, and the cutting performance of the blade will be impaired.

If the blade becomes dull, replace it with the included replacement blade. The blade is a consumable item that will eventually wear out. For more information about the useful life of the blade, refer to "8-4 About Blade Life."

1 Press the [MENU] key, then press the [▼] key to select [REPLACE KNIFE.]



2 Press the [ENTER] key. When the screen shown in the figure appears, the printing carriage simultaneously moves to the left.

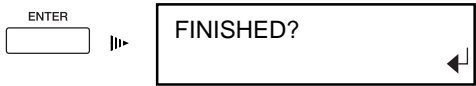

3 Loosen the tool-mounting screw shown in the figure, then remove the blade holder from the cutting carriage.

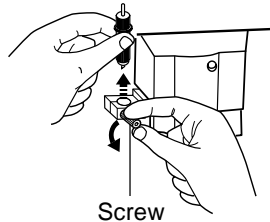

4 Remove the old blade.

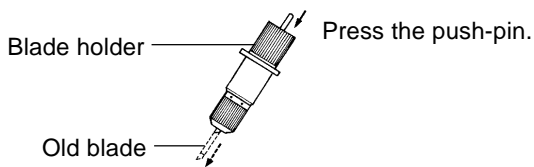

5 Replace with a new blade.

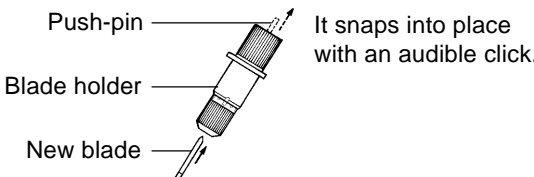

6 Support the tool-mounting screw from below and install the blade holder.

 **Point**
If installed without supporting the screw in this way, cutting quality may become poor.

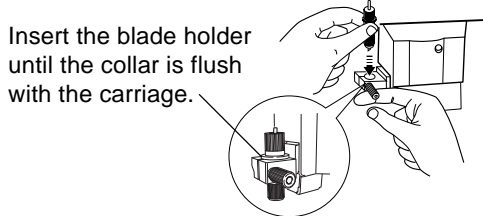

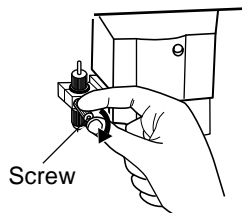

7 Tighten the tool-mounting screw. Tug the blade holder upward to make sure it does not come loose.



8 Close the front cover, then press the [ENTER] key.

How to Replace the Separating Knife

-  Do not touch the tip of the separating knife with your fingers. Doing so may result in injury.
-  Do not touch the operation panel while replacing the separating knife is in progress. The cutting carriage may move and cause injury.

If the separating knife becomes dull, replace it with the included replacement blade.

- 1** Press the [MENU] key, then press the [▼] key to select [REPLACE KNIFE].



- 2** Press the [ENTER] key. When the screen shown in the figure appears, the printing carriage moves to the left.

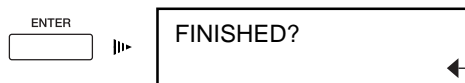

- 3** Open the front cover, then remove the separating knife.



Point

If the blade remains in the cutting carriage, use the tweezers in the cleaning kit to remove it.

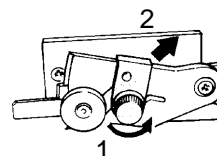

- 1) Loosen the screw until it slips out.
- 2) Grasp the screw portion, and slowly pull it out in the direction of the arrow. When doing this, do not pull it back toward you.

- 4** Replace with a new knife. The knife is secured in place by the magnet.

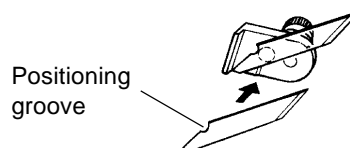

- 5** Install the separating knife.

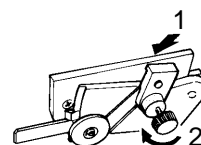

- 1) Grasp the screw portion and slowly insert it into the groove.
- 2) Tighten the screw. Take care to ensure that the knife does not slip out of position at this time.

- 6** Close the front cover and press the [ENTER] key.

5-5 Disposing of Discharged Ink

Dispose of ink in the drain bottle as described below.

Notice

Discharged ink is flammable and contains toxic ingredients. Never attempt to incinerate discharged ink or discard it with ordinary trash. Also, never dispose of it in sewer systems, river, or streams. Doing so may have an adverse impact on the environment.

Procedure for Disposing of Discharged Ink

- 1 Press and hold the [POWER] key for at least one second to switch off the sub power.
- 2 Remove the drain bottle and attach the bottom plug.

The bottom of the body

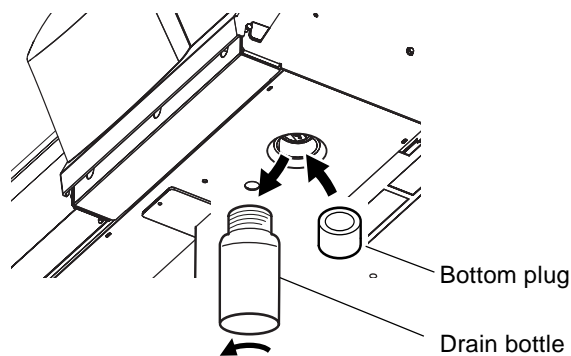

- 3 Dispose of discharged ink properly, in accordance with local laws and regulations.
- 4 Remove the bottom plug and attach the drain bottle.

Point

If any ink gets on your hands or clothing, wash it off as soon as possible. Ink stains may become difficult to remove if allowed to stand.

5-6 When Moving the Unit

When you move the machine, you first clean the heads. Cleaning of the heads requires four SOL INK cleaning cartridges.

When head cleaning finishes, detach the cables connected to the machine and remove the drain bottle.

Finally, secure the printing carriage in place to finish preparing the machine to be moved.

Notice

Be sure to use SOL INK cleaning cartridges. Use of any other type may result in breakdown.

Cleaning the Heads

1 If there is media loaded, remove the media.

2 Press the [MENU] key. Press the [▼] key to select [INK CONTROL].



3 Press the [▶] key.
The following screen appears.

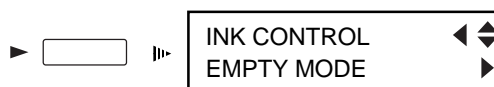

4 Press the [▼] key to select [HEAD WASH], then press the [ENTER] key.

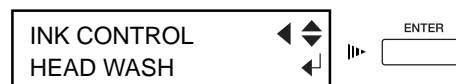

5 When the following screen appears, discard the discharged ink in the drain bottle.

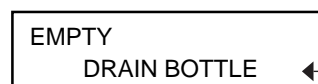

Notice

Be sure to discard the discharged ink. Attempting to clean the heads while discharged ink remains may cause discharged ink to overflow from the bottle. For more information about how to dispose of discharged ink, refer to "5-5 Disposing of Discharged Ink."

6 Attach the drain bottle and press the [ENTER] key.

The following screen appears.

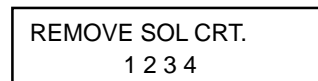

All numbers flash.

- 7** Pull out all the ink cartridges.
The following screen appears.

SET SOL CL-LIQUID 1 2 3 4

All numbers flash.

- 8** Insert SOL INK cleaning cartridges into all of the ink-cartridge ports.

Head cleaning starts. Cleaning may take some time. The cartridges are inserted and removed while the operation is in progress. Follow the messages on the display to carry out the procedure.

When head cleaning finishes, the sub power shuts of automatically.

- 9** Switch off the main power switch.

After Head Cleaning Has Finished

- 1** Detach the power cord and the cable connecting the unit to the computer.
- 2** Remove the drain bottle and attach the bottom plug. (Refer to "5-5 Disposing of Discharged Ink.")
- 3** Secure the printing carriage in place.
For information on how to secure in place, go to "1-3 Assembling and Installing" and refer to "Step 3: Remove the Protective Media."

Notice

After completing the move, immediately follow the steps in "1-3 Assembling and Installing" to carry out installation and fill with ink.

6. About the Menus

This chapter provides detailed item about the operation menus.

6-1 Menu Flowchart

For details about each of the menus, see the "6-2 Detailed Descriptions of the Menus."

When Switching on the Power

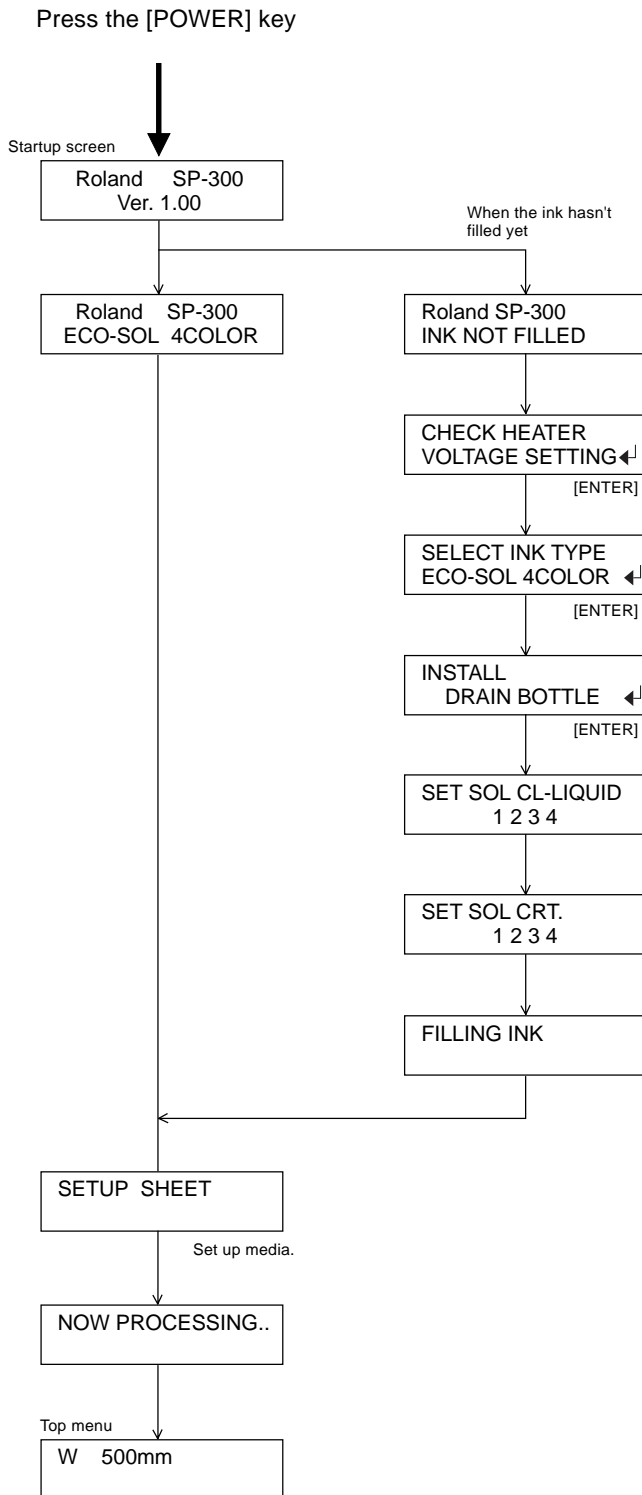

Language/unit Menu

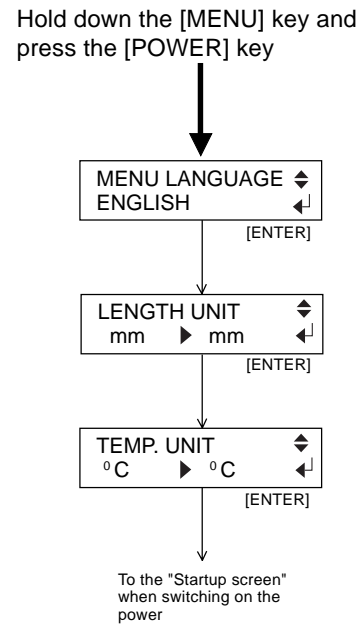

Cutting Configuration Menu

Press the [CUT CONFIG] key.

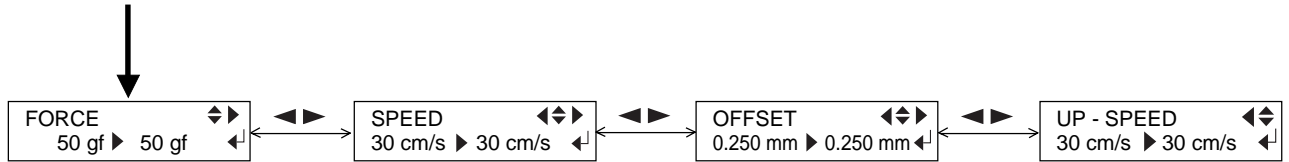

Maintenance Menu

Press and hold down the [CLEANING] key for one second or more.

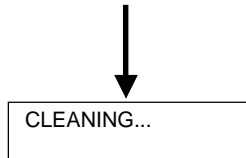

Hold down the [CLEANING] key, and press the [POWER] key.

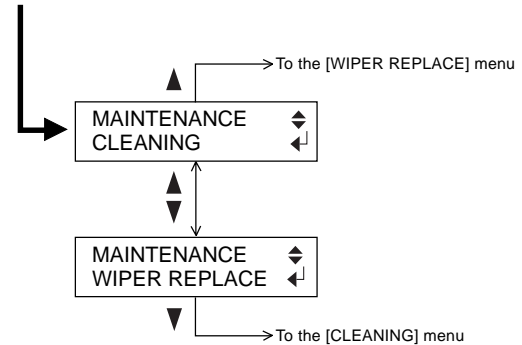

Heater Configuration Menu

Press the [HEATER CONFIG] key.

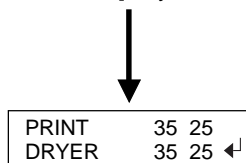

Main Menu

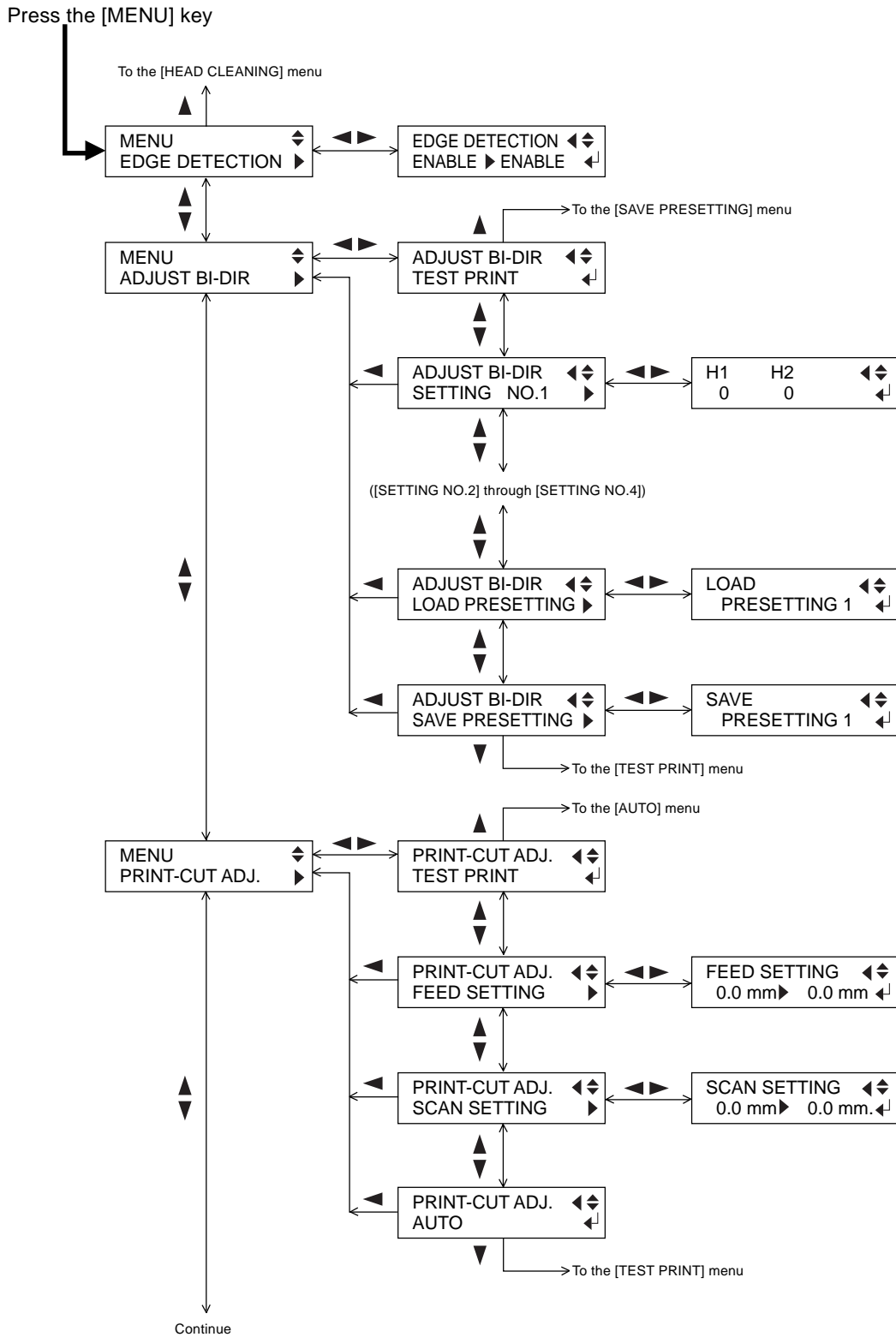

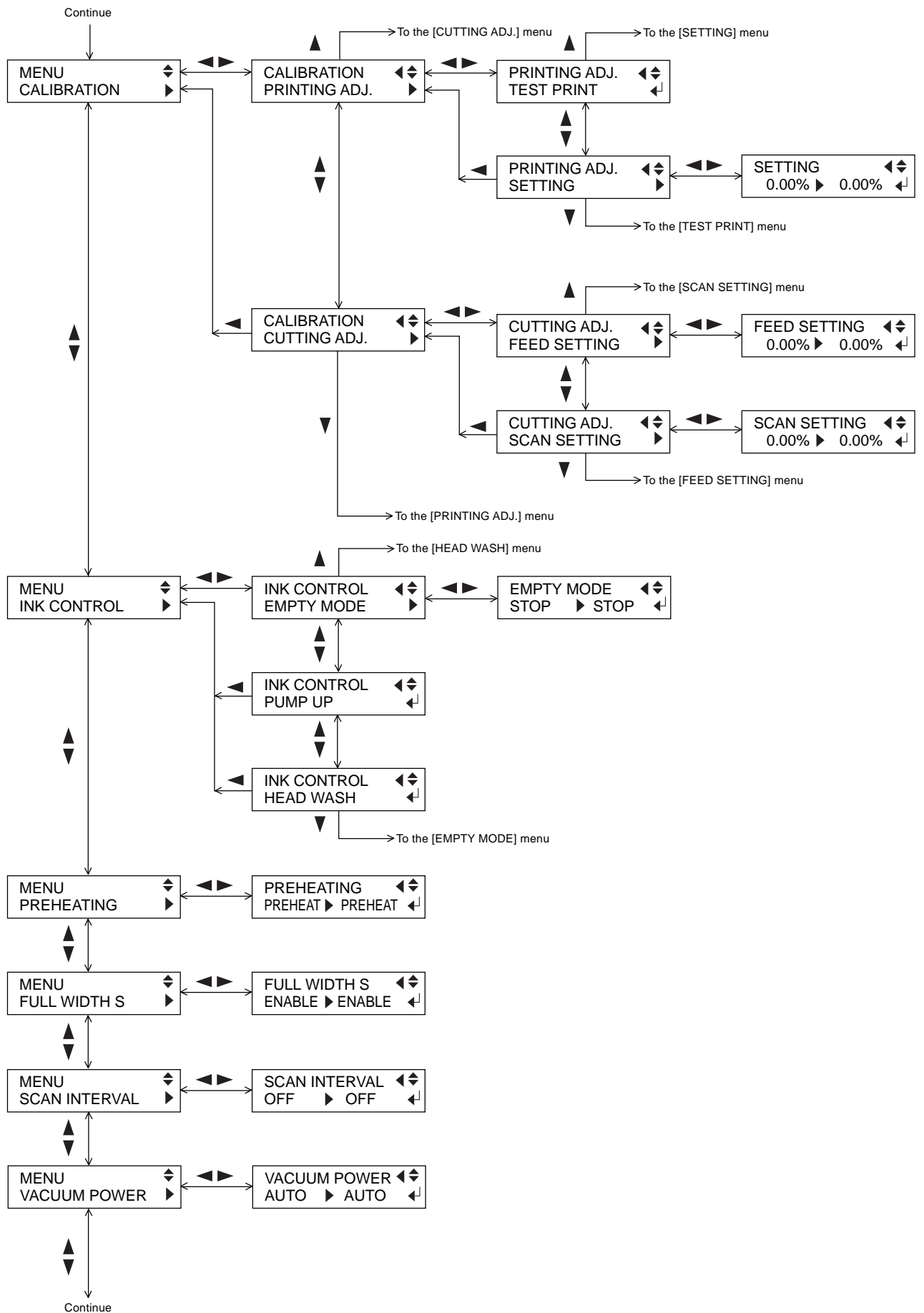

6-1 Menu Flowchart

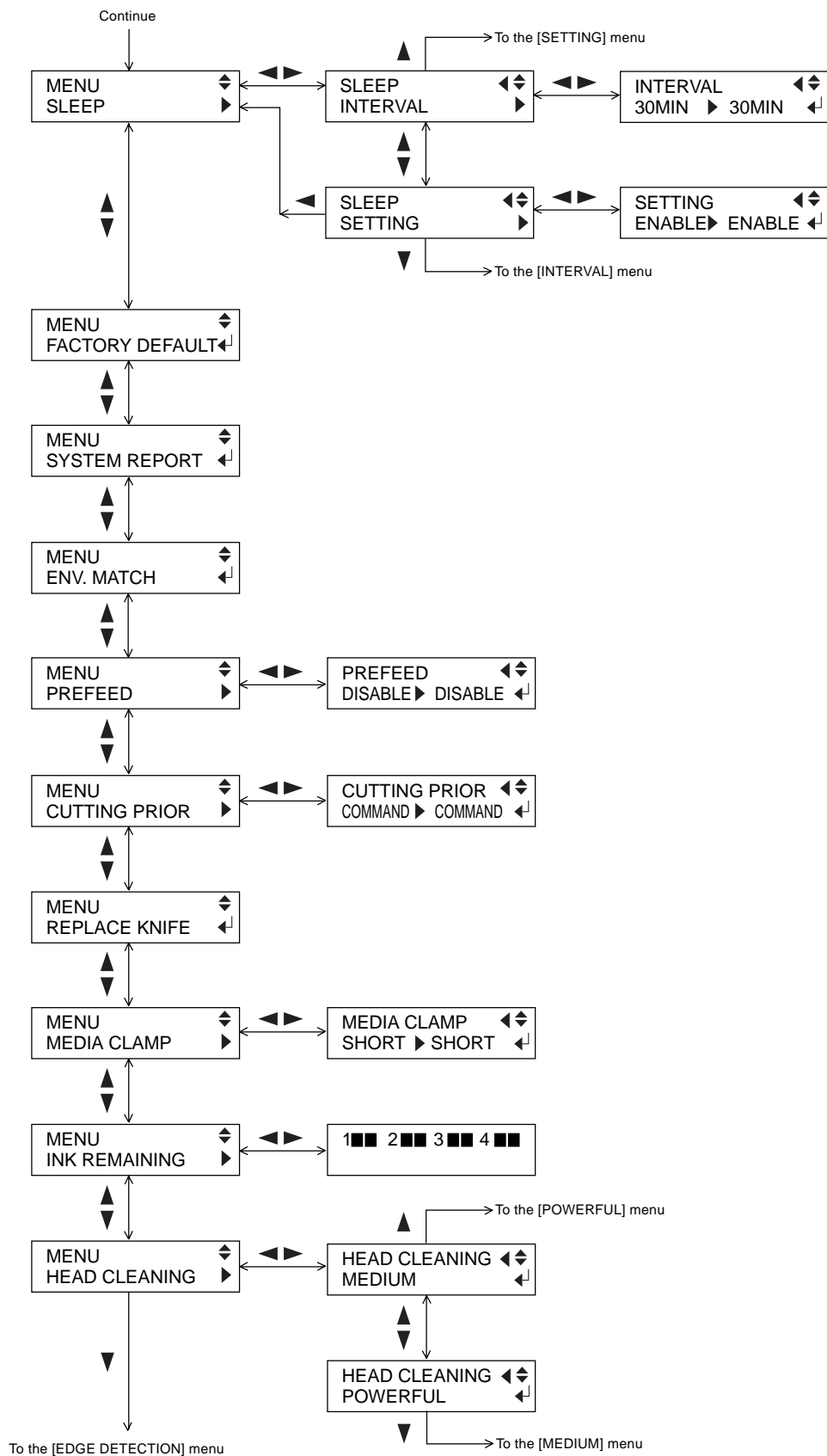

6-2 Detailed Descriptions of the Menus

Main Menu

[EDGE DETECTION]

Setting range: ENABLE, DISABLE
Default value: ENABLE

This specifies whether detection of the front and rear edges of the media is enabled or disabled.

This should normally be set to [ENABLE].

When loading transparent media, set this to [DISABLE]. When doing this, ensure a margin of 80 mm (3-3/16 in.) or more from the leading edge of the media to the start position for printing or cutting.

[ADJUST BI-DIR] > [TEST PRINT]

This prints a test pattern for adjustment of bidirectional printing.

[ADJUST BI-DIR] > [SETTING No.1 to 4]

Setting range: -30 to +10 (in steps of 1/2)
Default value: 0

This sets the adjustment values.

[ADJUST BI-DIR] > [LOAD PRESETTING]

This loads the adjustment values saved in memory 1 through 8.

[ADJUST BI-DIR] > [SAVE PRESETTING]

This saves the values of [SETTING NO.1 - 4] as [PRESETTING 1] through [PRESETTING 8]. You can save up to eight adjustment-value patterns.

[PRINT-CUT ADJ.] > [TEST PRINT]

This prints a test pattern for adjustment use.

[PRINT-CUT ADJ.] > [FEED SETTING]

Setting range: -5.0 to +5.0 mm (in steps of 0.1 mm)
Default value: 0 mm

This sets the adjustment value for the media-feed direction.

[PRINT-CUT ADJ.] > [SCAN SETTING]

Setting range: -5.0 to +5.0 mm (in steps of 0.1 mm)
Default value: 0 mm

This sets the adjustment value for the scan direction (the carriage-movement direction).

[PRINT-CUT ADJ.] > [AUTO]

Alignment of the printing and cutting positions is performed automatically.

[CALIBRATION] > [PRINTING ADJ.] > [TEST PRINT]

This prints a test pattern for verifying the adjustment.

[CALIBRATION] > [PRINTING ADJ.] > [SETTING]

Setting range: -2.00% to +2.00% (in steps of 0.05%)
Default value: 0%

This corrects for errors in the amount of feed of the grit rollers due the type of media. Be sure to make this setting when you have replaced the media with a different type. Make this setting again when horizontal stripes are plainly visible on printing results.

[CALIBRATION] > [CUTTING ADJ.] > [FEED SETTING]

Setting range: -2.00% to +2.00% (in steps of 0.01%)
Default value: 0%

This corrects for the cutting length (media-feed direction) when using the machine for cutting only. When using the machine for printing and cutting, always set the offset value to [0].

[CALIBRATION] > [CUTTING ADJ.] > [SCAN SETTING]

Setting range: -2.00% to +2.00% (in steps of 0.01%)
Default value: 0%

This corrects for the cutting length (carriage-movement direction) when using the machine for cutting only. When using the machine for printing and cutting, always set the offset value to [0].

[INK CONTROL] > [EMPTY MODE]

Setting range: CONT., STOP
Default value: STOP

When replacement of the ink cartridge becomes necessary while printing is in progress, this setting determines whether printing continues or pauses. This setting is used when the ink cartridge cannot be changed immediately during printing, such as during unattended operation at night.

[CONT.] causes printing to continue without pause even if ink refilling becomes necessary. To replace an ink cartridge, press the [PAUSE] key to pause operation, then replace with a new cartridge. Pressing the [PAUSE] key again resumes printing.

Printing continues with the small amount of ink remaining, so the printed image may become faint as the ink runs out. In general, it would be possible to perform about 1 m² (10 ft²) of printing once this message appears, although the actual amount varies widely according to the amount of ink needed for the particular image. Printing is continued only for the data currently being printed. Operation stops after one image is output.

[STOP] causes operation to pause immediately when the ink cartridge needs to be changed. Printing is resumed by replacing the cartridge. Note, however, that the colors of an image in progress may no longer match perfectly. Before you perform lengthy printing, replace with ink cartridges that contain enough ink.

[INK CONTROL] > [PUMP UP]

This drains ink from the printing heads.

[INK CONTROL] > [HEAD WASH]

This washes the printing heads using optionally available cleaning cartridges.

[PREHEATING]

Setting range: PREHEAT, MENU, OFF
Default value: PREHEAT

This sets the temperature of the printing heater and the dryer when no media is loaded and set up.

[PREHEAT]: This maintains the warm-up temperature (which is lower than the normal operating temperature) when no media is loaded and set up. When media is loaded and set up, the heaters are at the temperature values set at the heater configuration menu.

[MENU]: This maintains the heaters at the temperature values set at the heater configuration menu even when no media is loaded and set up.

[OFF]: The heaters do not operate when no media is set up and loaded. When media is loaded and set up, the heaters are at the temperature values set at the heater configuration menu.

[FULL WIDTH S]

Setting range: ENABLE, DISABLE
Default value: ENABLE

This sets the movement width of the printing carriage during printing. Using this function may improve printing quality because the speed of feeding media becomes uniform, but printing may take more time. When you're using the heater unit, be sure to set this menu item to [ENABLE].

[ENABLE]: The movement width of the printing carriage is always the full range.

[DISABLE]: The movement width varies according to the printing data.

[SCAN INTERVAL]

Setting range: OFF, 0.1 to 10.0 sec. (in steps of 0.1 sec.)
Default value: OFF

This sets the ink-drying time. If problems with ink stains occur, setting this to a longer value may improve printing quality.

[VACUUM POWER]

Setting range: AUTO, 0 to 100% (in steps of 10%)
Default value: AUTO

This adjusts the suction force of the fan installed under the platen to make the media contact the platen.

Adjust this value when the media warps due to heat or sticks to the platen. Increasing the value makes the suction force stronger, but because it lowers the temperature of the platen, the media may become difficult to warm.

[AUTO]: The suction force is adjusted automatically according to the width of media. Set this menu item to [AUTO] normally.

[0 to 100%] (in steps of 10%): The suction force remains constant at the set value.

[SLEEP] > [INTERVAL]

Setting range: 15 to 120 min. (in steps of 15 min.)
Default value: 30 min.

This sets the time until the machine enters the sleep mode.

[SLEEP] > [SETTING]

Setting range: ENABLE, DISABLE
Default value: ENABLE

This sets whether the power-saving feature is enabled.

When set to [ENABLE], the machine enters the sleep mode when the time set with the [INTERVAL] menu item is reached.

[FACTORY DEFAULT]

This returns all menu settings to their original values when shipped from the factory. For more about the factory defaults for the various settings, see the "Default value" entry for each menu setting in this section.

[SYSTEM REPORT]

This prints the current status of settings and other system information.

[ENV. MATCH]

This performs automatic adjustment on the machine to obtain a state optimized to the operating environment (temperature and humidity).

[PREFEED]

Setting range: DISABLE, ENABLE
Default value: DISABLE

This specifies whether the media prefeed function is enabled.

When set to [ENABLE], an amount of media equal to the size of the data sent from the computer is fed out first, and then printing or cutting is performed.

When using the [PREFEED] function, set [EDGE DETECTION] to [ENABLE].

[CUTTING PRIOR]

Setting range: COMMAND, MENU
Default value: COMMAND

When set to [COMMAND], cutting conditions set with a program are to be given priority.

When set to [MENU], cutting is performed using the values set with the machine.

[REPLACE KNIFE]

This setting is used when replacing the separating knife, or when installing or removing the media-cutting blade.

[MEDIA CLAMP]

Setting range: LONG, SHORT, NONE
Default value: SHORT

This makes the setting for the type of media clamps used.

[LONG]: Select this value when you're using the long media clamps. Note that the long media clamps interfere with the separating knife, so when [LONG] is selected, media-separation operations are not performed.

[SHORT]: Select this value when you're using the short media clamps.

[NONE]: Select this value when you're not using any media clamps.

[INK REMAINING]

This shows the amount of ink left after each of the ink cartridges has been installed. The fewer the markers, the less ink is left.

If a partially used ink cartridge is removed and reinstalled, or if a partially used ink cartridge is installed, the cartridge is taken to be unused, and the displayed amount of remaining ink is not true.

[HEAD CLEANING] > [MEDIUM]

This performs cleaning of the printing heads. This performs cleaning that is more powerful than the cleaning carried out by pressing the [CLEANING] key. If no improvement is obtained by performing cleaning several times using the [CLEANING] key, then execute this menu item.

This cleaning causes more head wear and uses up more ink than cleaning using the [CLEANING] key, so you should execute it only as seldom as necessary.

[HEAD CLEANING] > [POWERFUL]

This performs cleaning of the printing heads. This performs cleaning that is more powerful than the cleaning carried out by using [MEDIUM]. If no improvement is obtained by performing cleaning several times using [MEDIUM], then execute this menu item. This cleaning causes more head wear and uses up more ink than cleaning using [MEDIUM], so you should execute it only as seldom as necessary.

Cutting Configuration Menu**[FORCE]**

Setting range: 30 to 300gf (in steps of 5gf)
Default value: 50gf

This sets the blade force used during cutting.

When [CUTTING PRIOR] on the main menu has been set to [COMMAND], the program's settings for the cutting conditions take priority. To give priority to the cutting conditions set on the machine, turn off the program settings, or set the [CUTTING PRIOR] menu item to [MENU].

[SPEED]

Setting range: 1 to 30cm/s (in steps of 1cm/s)
Default value: 30cm/s

This sets the cutting speed used during cutting.

When [CUTTING PRIOR] on the main menu has been set to [COMMAND], the program's settings for the cutting conditions take priority. To give priority to the cutting conditions set on the machine, turn off the program settings, or set the [CUTTING PRIOR] menu item to [MENU].

[OFFSET]

Setting range: 0.000 to 1.500mm (in steps of 0.025mm)
Default value: 0.250mm

This sets the blade offset used during cutting.

When [CUTTING PRIOR] on the main menu has been set to [COMMAND], the program's settings for the cutting conditions take priority. To give priority to the cutting conditions set on the machine, turn off the program settings, or set the [CUTTING PRIOR] menu item to [MENU].

[UP-SPEED]

Setting range: 1 to 30cm/s (in steps of 1cm/s)
Default value: 30cm/s

This sets the up speed for the blade (the speed when the blade is raised).

When [CUTTING PRIOR] on the main menu has been set to [COMMAND], the program's settings for the cutting conditions take priority. To give priority to the cutting conditions set on the machine, turn off the program settings, or set the [CUTTING PRIOR] menu item to [MENU].

Heater Configuration Menu

[PRINT/DRYER]

Setting range: OFF, 35 to 50°C (in steps of 1°)
or 94 to 122°F (in steps of 2°)

These specify the preset temperature for the printing heater and for the dryer. They also display the actual temperatures. The value on the left side of the display is the preset temperature, and the value on the right side is the actual temperature.

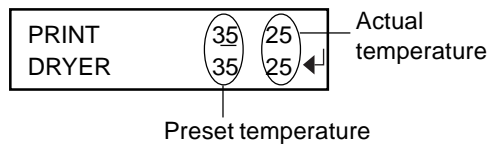

Language/unit Menu

[MENU LANGUAGE]

Setting range: ENGLISH, JAPANESE

This specifies the language used for the display. After you have made your selection, pressing the [ENTER] key displays the [LENGTH UNIT] menu.

[LENGTH UNIT]

Setting range: mm, inch

This specifies the measurement unit for the lengths shown on the display. After you have made your selection, pressing the [ENTER] key displays the [TEMP. UNIT] (temperature unit) menu.

[TEMP. UNIT]

Setting range: °C, °F

This specifies the measurement unit for temperatures shown on the display. After you have made your selection, pressing the [ENTER] key exits the menus, and initialization starts.

Maintenance Menu

[MAINTENANCE] > [CLEANING]

This performs operations for cleaning around the printing heads using the cleaning kit. For more information, go to "5-2 Cleaning the Printing Heads" and refer to "Cleaning Using the Cleaning Kit."

[MAINTENANCE] > [WIPER REPLACE]

This performs operations for replacing the wiper. For more information, go to "5-2 Cleaning the Printing Heads" and refer to "Replacing the Wiper."

7. What to Do If...

This section describes error messages that may appear on the display and how to resolve problems that can occur during operation.

7-1 What to Do If...

The Machine Doesn't Run

The Machine

Is the power switched on?

After you switch on the main power, press the [POWER] key and make sure the POWER light illuminates.

Is the [SETUP] light illuminated?

Load media correctly, then lower the sheet loading lever and close the front cover.

Is the front cover open?

Close the front cover.

Is the top menu displayed?

If the top menu isn't displayed, printing doesn't start even when data is sent from the computer. Press the [MENU] key to display the top menu.



Top menu

Is the PAUSE light illuminated?

If the PAUSE light is lighted, the unit has been paused. To resume printing or cutting, press the [PAUSE] key. The PAUSE light goes dark and printing or cutting resumes.

Has ink run out?

When printing or cutting data is sent while the screen shown in the figure is displayed, a message appears and a warning beep sounds. At the same time, operation pauses. When the ink cartridge is replaced with a new one, printing or cutting starts.



This screen shows the ink 1 is ran out.

Is any message shown on the display?

Refer to "7-2 Responding to a Message" elsewhere in this chapter.

The Connector Cable

Is the cable connected?

Connect the cable securely.

Are you using a lengthy connector cable or a USB hub?

Use a shielded USB cable having a length of three meters or less. Never use a USB hub or the like.

Attractive Printing or Cutting Is Impossible

The Results of Printing Are Coarse

Do the printing heads exhibit dot drop-out?

Carry out a printing test and make sure no dot drop-out occurs. If dot drop-out is present, perform cleaning. For more information, refer to "3-1 Points to Check Before Performing Output", the section "Checking the State of the Printing Heads" and "5-2 Cleaning the Printing Heads."

Have you carried out feed correction?

Large misalignment in the amount of feed of the media may result in printing that seems coarse or in horizontal stripes. Either make the setting on the computer to match the type of media you're using, or go to "4-2 Making Corrections for Printing" and refer to "Feed Correction -- Setting the Adjustment Value" to make the setting for correction on the printer.

Have you carried out bidirectional correction?

If you're performing bidirectional printing, use the [ADJUST BIDI] menu to perform correction. (Go to "4-2 Making Corrections for Printing" and refer to "Bidirectional Correction -- Setting the Adjustment Value.") The optimal adjustment value may vary, depending mainly on the thickness of the media. Set or select an adjustment value that is suited to the media.

Is the printing heater set at an appropriate temperature?

The results of printing may be coarse when the media is not warm enough. In particular, the edges of the media tend not to become as warm as the center, which may result in ink drips or unevenness, depending on the printing data. If this happens, increase the preset temperature and perform printing again. If the printing results don't improve even when you increase the preset temperature, the ambient temperature may be too low. Be sure to perform printing in the recommended operating environment. Setting the [SCAN INTERVAL] menu item for the printer may improve printing quality. Please refer to "6-2 Detailed Descriptions of the Menus."

Is the printer installed in a level and stable location?

Never install the machine in a location where it is tilted or where it may wobble or experience vibration. Also, ensure that the printing heads are not exposed to wind or blown air. These factors may lead to missing dots or reduced printing quality.

Is the media loaded and set up correctly?

If the media is not loaded and set up correctly, media feed may not be smooth, or printing or cutting may be adversely affected. Refer to the following section, "The Media Comes Loose from the Bed or Feed Is Unstable," and take action accordingly.

Colors Are Not Stable

Did you shake the ink cartridges gently before installing them?

Before you install a new ECO-SOL INK cartridge, gently shake the cartridge.

Is the media loaded and set up correctly?

If the media is not loaded and set up correctly, media feed may not be smooth, or printing or cutting may be adversely affected. Refer to the following section, "The Media Comes Loose from the Bed or Feed Is Unstable," and take action accordingly.

Was printing paused partway through?

When printing is paused, the coloring at the seam may be altered when printing resumes. Avoid pausing printing. With the factory-default settings, printing pauses when an ink cartridge runs empty. Before you perform lengthy printing, check the amount of ink remaining in the ink cartridges.

Printing may also pause when data is not sent from the computer quickly enough. We recommend not performing any other tasks with the computer while printing is in progress.

Is the printer installed in a level and stable location?

Never install the machine in a location where it is tilted or where it may wobble or experience vibration. Also, ensure that the printing heads are not exposed to wind or blown air. These factors may lead to missing dots or reduced printing quality.

■ Cutting Is Misaligned or Skewed**Is the media loaded and set up correctly?**

If the media is not loaded and set up correctly, media feed may not be smooth, or printing or cutting may be adversely affected. Refer to the following section, "The Media Comes Loose from the Bed or Feed Is Unstable," and take action accordingly.

Are the settings for the cutting conditions appropriate?

Misalignment or skewing may occur if the cutting speed is too fast or the blade force is too high. Try changing the cutting conditions. With media having a strong adhesive layer, the adhesive layer reattaches to itself immediately after cutting. However, if a cutting test shows that the peeling of the media and the blade traces on the backing paper are optimal, then the media is being cut properly. Be careful not to make the blade force too high.

Is the length of printing too long?

For printing and cutting in particular, the longer the page length (that is, the longer the distance the media is returned after printing), the greater is the chance of misalignment occurring. It is a good idea to keep the size of each single page to the minimum necessary.

Are you using media that exhibits large expansion and contraction?

When you're performing printing and cutting, misalignment occurs if the media expands or contracts. If this happens, try performing printing with crop marks, then setting the base point and one or more align points and performing cutting. This corrects for expansion and contraction of the media.

Has the [ENV. MATCH] menu item been executed?

The printing length in the carriage direction may change depending on the operating environment (temperature and humidity). Execute [ENV. MATCH] to adjust the machine to match the operating environment. (Refer to "1-3 Assembling and Installing" and see "Step 8: Match the Machine to the Environment Where Installed.")

Is the offset value for [CUTTING ADJ.] something other than zero "0"?

When you're performing printing and cutting, go to [CALIBRATION] and set the [CUTTING ADJ.] menu item to "0."

■ The Media Becomes Soiled When Printed**Is the media loaded and set up correctly?**

If the media is not loaded and set up correctly, media feed may not

be smooth, or printing or cutting may be adversely affected. Refer to the following section, "The Media Comes Loose from the Bed or Feed Is Unstable," and take action accordingly.

Are the printing heads dirty?

The following may cause ink to drip on the media during printing.

- Dust or fiber-containing grime around the heads may have absorbed ink.
- The heads scraping the media may have caused ink to fail to be discharged, resulting in ink buildup in the heads.

If this happens, refer to "5-2 Cleaning the Printing Heads -- If Drop-out Persists Even After Carrying Out Cleaning Several Times" and clean the heads. We recommend carrying out periodic head cleaning. Also, before you start printing, perform a printing test to make sure there is no dot drop-out.

Are the pinch rollers dirty?

Refer to "5-3 Other Cleaning Tasks" and perform periodic cleaning of the pinch rollers.

■ The Media Comes Loose from the Bed or Feed Is Unstable

Unstable media feed may cause various problems. The quality of printing or cutting may be affected, the media may scrape the printing heads, or misalignment or jamming of the media may occur. Refer to the following and take appropriate action.

Is the media loaded and set up correctly?

If the media is not loaded correctly, it may come loose, or media feed may not be straight. Refer to "2-3 Loading Media" and make sure the media is loaded correctly. For roll media in particular, it is important to make sure the media is loaded perfectly straight and is stretched taut.

Is the media striking against anything?

If the media strikes some obstruction that subjects the media to excessive force or impedes its movement, the quality of printing or cutting may be adversely affected or the media may jam or become misaligned. Remove the obstruction and ensure that the media feed is smooth.

Has the media come loose from the bed, or is the media warped?

- 1) Make sure the media is loaded correctly and does not strike some obstruction.
- 2) Use the media clamps when printing. Some media easily warps the edge.
- 3) Load media when the heaters are cool (at standby temperature), and ensure that the media is warmed gradually.
- 4) Never allow the media to set up for any length of time. After finishing printing, raise the sheet loading lever or remove the media. Heating the media for a long time may cause wrinkles of the media.

Is the media too thick?

Media that is too thick may not only cause unstable feed, but may scrape the printing heads, resulting in malfunction. Never use such media.

Are the grit rollers dirty?

Check to make sure the grit rollers are free of buildup of foreign material such as media scraps. If such buildup is present, refer to "5-3 Other Cleaning Tasks" and perform cleaning.

The Media Becomes Jammed

If [MOTOR ERROR: TURN OFF POWER] Appears and Operation Stops

Follow the steps below to clear the error.

1. Press the [POWER] key to switch off the sub power.
2. Remove the jammed media. Cut off any creased or torn portions.
3. Press the [POWER] key to turn on the sub power.
4. Correct whatever caused the media to jam.
5. Press the [CLEANING] key to perform head cleaning and a printing.



Point

Jammed media may damage or soil the printing heads. Be sure to perform head cleaning first before sending the printing data.

What to Do If the Printing Carriage Does Not Operate

During operation, if for some reason the printing carriage does not return to the standby position, then following the procedure, cap the printing heads, and contact your authorized Roland DG Corp. dealer or service center.

If the printing carriage is allowed to stand for a prolonged period with the printing heads uncapped (that is, with the printing carriage over the platen), the heads may become clogged or even damaged.

1. Make sure the main power is switched off, then detach the cover on the right side of the machine.
2. Open the front cover and move the printing carriage to the standby position by hand.

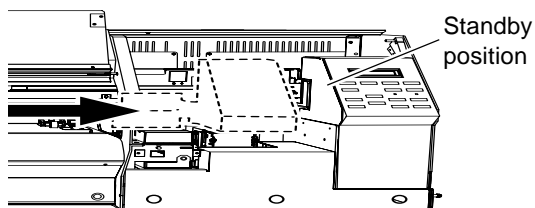

3. Insert the oval end of the pipe included with the machine into the hole in the bottom of the machine, then rotate the pipe. The cap unit rises.

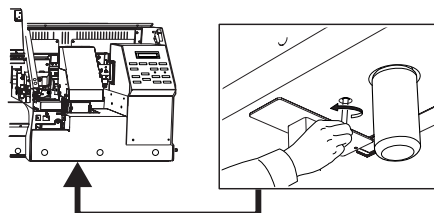

4. Align the guides at the two ends of the cap unit with the guides at the two ends of the printing carriage. Turn the pipe more to bring the cap unit close to the printing carriage.

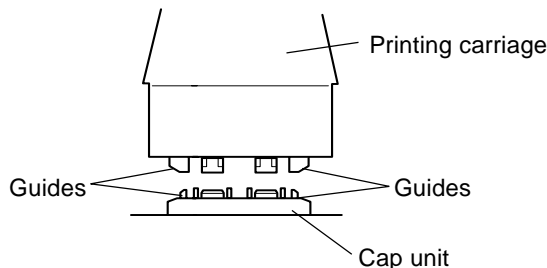

5. When the printing carriage comes into contact with the caps, rotate the pipe one or two turns more.

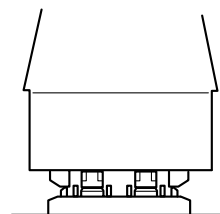

Make sure the printing carriage and the caps are touching, then contact your authorized Roland DG Corp. dealer or service center.

7-2 Responding to a Message

Action-prompting Messages

These are the main messages that appear on the machine's display to prompt correct operation. They do not indicate any error. Follow the prompts and take action accordingly.

[CLOSE THE COVER]

Close the front cover and the cover. For safety, the carriage does not operate while a cover is open.

[SHEET NOT LOADED SETUP SHEET]

Load media. This message appears when an attempt to perform a printing test was made while no media was loaded.

[1 ■ 2 ■ 3 ■ 4 ■]

Only a small amount of ink remains. Replace the cartridge indicated by the flashing number with a new cartridge.

[SET SOL CRT. 1 2 3 4]

Insert the ink cartridge indicated by the flashing number. This message appears at times such as during cartridge replacement.

[REMOVE SOL CRT. 1 2 3 4]

Remove the ink cartridge indicated by the flashing number. This message appears at times such as during head cleaning.

[SET SOL CL-LIQUID 1 2 3 4]

Insert the cleaning cartridge indicated by the flashing number. This message appears at times such as during head cleaning.

[REMOVE SOL CL 1 2 3 4]

Remove the cleaning cartridge indicated by the flashing number. This message appears at times such as during head cleaning.

[EMPTY DRAIN BOTTLE]

Remove the drain bottle from the machine, discard the collected ink, then reinstall the drain bottle. Press the [ENTER] key to continue. This message appears before operations that will discharge large amounts of ink.

[INSTALL DRAIN BOTTLE]

Make sure that the drain bottle is set in position. Set the drain bottle in place. Press the [ENTER] key to continue.

[TIME FOR MAINTENANCE]

It is time to clean the printing heads. After checking, press the [ENTER] key. Go to "5-2 Cleaning the Printing Heads" and refer to "If Drop-out Persists Even After Carrying Out Cleaning Several Times," and perform cleaning promptly.

[TIME FOR WIPER REPLACE]

It is time to replace the wiper. After checking, press the [ENTER] key. Go to "5-4 Replacing Consumable Parts" and refer to "Replacing the Wiper," and perform replacement promptly.

[TIME FOR SPONGE REPLACE]

It is time to replace the ink-absorbing material. Go to "5-4 Replacing Consumable Parts" and refer to "Replacing the Ink-Absorbing Material," and perform replacement promptly. After replacing, press the [ENTER] key.

[PRESS THE POWER KEY TO CLEAN]

When the main power switch is left on and the machine remains unused for about a month, a warning beep sounds and this message appears. Refer to "4-7 When Not in Use for a Prolonged Period," and perform cleaning.

Error Message

This describes the error messages that may appear on the machine's display, and how to take action to remedy the problem. If the action described here does not correct the problem, or if an error message not described here appear, contact your vendor or the nearest Roland DG Corp. service center.

[SHEET SET ERROR SET AGAIN]

The sheet loading lever was lowered while no media was loaded.

Raise the sheet loading lever, place media at the correct location on the bed, then lower the lever again. This message appears when the media is not at the correct location. Refer to "2-3 Loading Media."

An attempt was made to load media that is too small.

Raise the sheet loading lever, then replace the media with media of a loadable size.

[EDGE DETECTION] is set to [ENABLE], but transparent media was loaded.

Raise the sheet loading lever, set the [EDGE DETECTION] menu item to [DISABLE], then reload the media. (Refer to "6-2 Detailed Descriptions of the Menu.")

[PINCHROLL ERROR INVALID RIGHT POS]

The right pinch roller is positioned at a location where it does not pinch the media.

Raise the sheet loading lever and move the right pinch roller to the correct location. (Refer to "2-3 Loading Media.")

[PINCHROLL ERROR INVALID LEFT POS]

The left pinch roller is positioned at a location where it does not pinch the media.

Raise the sheet loading lever and move the left pinch roller to the correct location. (Refer to "2-3 Loading Media.")

[DATA ERROR CANCELING...]

Output was stopped because a problem was found in the data received.

Operation cannot be continued. Check for problems with the connector cable or the computer, then redo the operation, starting with reloading the media.

[SHEET TOO SMALL CONTINUE?]

The size of the data is larger than the printing or cutting area of the loaded media.

To continue performing output without correcting this, press the [ENTER] key. At this time, the portion extending beyond the printing or cutting area is not output. To stop output, stop sending data from the computer, then raise the sheet loading lever. Make the printing or cutting area wider such as by replacing the media with a larger piece of media or by changing the positions of the pinch rollers, then send the data again.

[CAN'T PRINT CROP CONTINUE?]

The size of the data including the crop marks is larger than the printing area of the loaded media.

To continue performing output without correcting this, press the [ENTER] key. At this time, the portion extending beyond the printing or cutting area and crop marks is not output. To stop output, stop sending data from the computer, then raise the sheet loading lever. Make the printing or cutting area wider such as by replacing the media with a larger piece of media or by changing the positions of the pinch rollers, then send the data again.

The size of the data being output is too small.

Make the size of the data of the scan direction at least 65 mm (2-9/16 in.). To continue performing output without correcting this, press the [ENTER] key. At this time, the data is output without printing the crop marks. To stop output, stop sending data from the computer, then raise the sheet loading lever. Change the size of the data, then send the data again.

The size of the data of the feed direction is not limited.

[CROPMARK ERROR NOT FOUND]

Automatic detection of crop marks could not be accomplished.

Load the media at the correct position and perform detection of crop marks again. Depending on the media, it may not be possible to detect crop marks automatically. If repeating automatic crop-mark detection results in an error again, then perform manual crop-mark detection.

[CANCELED FOR PROTECTING MOTOR]

Continuous operation caused the pump motor to become hot, so operation was paused.

Press any key to cancel the error. Allow the unit to stand for about 40 minutes, then resume operation.

[CHECK HEATER VOLTAGE SETTING]

The heaters didn't reach their preset temperatures although approximately 20 minutes had passed since printing started. Raise the temperature of the room if it is low.

When this message appears in spite of using the machine in the recommended environment (refer to "8-1 Specifications"), check if the voltage switches match the voltage of the region where the machine is used.

To continue waiting for reaching the preset temperature, press the [ENTER] key.

To start printing although the heaters have not reached their preset temperature, press the [PAUSE] key.

[MOTOR ERROR TURN OFF POWER]

A motor error occurred.

Operation cannot be continued. [Use the [POWER] key to switch the power off and back on again. After rectifying the cause of the error (a media jam or the like), switch on the power. Never leave the unit with the printing carriage not in standby position.

[TEMPERATURE IS TOO LOW]

The air temperature where installed is lower than the minimum ambient temperature at which the unit can operate (approx. 5°C [41°F]).

Operation cannot be continued. Use the [POWER] key to switch the power off. First raise the temperature of the area where installed, then switch on the power.

[TEMPERATURE IS TOO HIGH]

The air temperature where installed is higher than the maximum ambient temperature at which the unit can operate (approx. 40°C [104°F]).

Operation cannot be continued. Use the [POWER] key to switch the power off. First lower the temperature of the area (15 to 35°C [59 to 95°F] where installed), then switch on the power.

[HEATER VOLTAGE SETTING ERROR]

The heater temperature experienced a sudden rise because the settings for the voltage switches are incorrect.

Operation cannot be continued. Press the [POWER] key to switch off the power, then switch off the main power switch. Next, go to "1-3 Assembling and Installing" and refer to "Step 5: Set the Voltage Switches," and make the correct settings for the voltage switches. Finally, switch on the main power switch, then switch on the sub power.

[AVOIDING DRY-UP TURN OFF POWER]

Forced movement to the standby position was performed in order to prevent the heads from drying out.

Operation cannot be continued. Press the [POWER] key to switch the power off and back on again. Opening the front cover while printing is in progress causes an emergency stop, and when the machine is left in this state for ten minutes or more, forced retraction of the printing heads is performed.

[CARRIAGES ARE SEPARATED]

The cutting carriage and the printing carriage were improperly disconnected.

A problem such as a media jam occurred, impeding correct operation. Operation cannot be continued. Press the [POWER] key to switch the power off and back on again.

[SERVICE CALL No: * * * *]

An unrecoverable error occurred, or part replacement that must be performed by a service technician is required.

Check the number shown on the display, then press the [POWER] key to switch off the power. After you switch off the power, inform your authorized Roland DG Corp. dealer or service center of the number that appeared on the display.

8. Appendix

8-1 Specifications

		SP-300
Printing/Cutting method		Piezo ink-jet method/media-moving method
Printing/Cutting width (*1)		147 to 736 mm (5-13/16 to 29 in.)
Acceptable media widths		182 to 762 mm (7-3/16 to 30 in.)
Ink cartridges	Type	Exclusive ECO-SOL INK cartridge
	Capacity	220 cc ±5 cc
	Color	The four colors cyan, magenta, yellow, black
Printing resolution (Printing dot resolution)		Max. 1440 dpi
Acceptable tool		Special blade for CAMM-1 series
Cutting Speed		10 to 300 mm/s
Blade force		30 to 300 gf
Blade offset compensation		0.000 to 1.500 mm
Setting range of the preset temperature (*2)	Printing Heater	35 to 50°C (94 to 122°F)
	Dryer	35 to 50°C (94 to 122°F)
Software resolution (When cutting)		0.025 mm/step
Distance accuracy (Printing while using heater)		Error of less than ±0.4% of distance traveled, or 0.5 mm, whichever is greater (in Roland SV-G-610G, print travel: 1 m, temperature: 20°C, humidity: 50%, heater temperature setting: 40°C)
Distance accuracy (When cutting) (*3)		Error of less than ±0.4% of distance traveled, or 0.3 mm, whichever is greater When distance correction ([CUTTING ADJ.] menu item) has been performed: error of less than ±0.2% of distance traveled, or 0.1 mm, whichever is greater
Repetition accuracy (When cutting) (*3)		0.1 mm or less (excluding stretching/contraction of the media)
Repetition between printing and cutting (*3)		±0.5 mm max. at 25°C (excluding possible shift caused by expansion/contraction of the media and/or by reloading the media)
Interface		USB interface (compliant with Universal Serial Bus Specification Revision 1.1)
Power-saving function		Automatic sleep feature (compliant with the International ENERGY STAR® Office Equipment Program)
Power supply	Voltage and frequency	AC 100 to 120 V ±10% 50/60 Hz or AC 220 to 240 V ±10% 50/60 Hz
	Required power capacity	6.0A (100 to 120 V) or 3.0 A (220 to 240 V)
Power consumption	Printing mode	Approx. 650 W
	Sleep mode	Approx. 29 W
Acoustic noise level	Printing mode	64 dB (A) or less (according to ISO 7779)
	Standby mode	40 dB (A) or less (according to ISO 7779)
Dimensions (With stand)		1720 [W] x 770 [D] x 1275 [H] mm (67-3/4 [W] x 30-3/8 [D] x 50-1/4 [H] in.)
Weight (With stand)		130 kg (287 lb.)
Packed dimensions		1890 [W] x 830 [D] x 900 [H] mm (74-1/2 [W] x 32- 3/4 [D] x 35-1/2 [H] in.)
Packed weight		161 kg (355 lb.)
Environment	Power on (*4)	Temperature: 15 to 32°C (59 to 90°F) (20°C [68°F] or more recommended), Humidity: 35 to 80% (no condensation)
	Power off	Temperature: 5 to 40°C (41 to 104°F), Humidity: 20 to 80% (no condensation)
Included items		Exclusive stand, cleaning liquid cartridges, media flanges, small media clamps, large media clamps, blade, blade holder, replacement blade for separating knife, ink-absorbing materials, cleaning kit, CD-ROMs, power cord, manuals

*1 The length of printing or cutting is subject to the limitations of the program or driver.

*2 The heater temperature may not reach the preset temperature depending on ambient conditions or the width of the media.

*3 Accuracy is assured within a range in which the media-feed length is 3,000 mm or less and expansion or contraction due to heater use is excluded.
And the setting for heater use requires a warm-up period of about 5 minutes after powerup. (Time may vary depending on the operating environment.)

*4 Environment

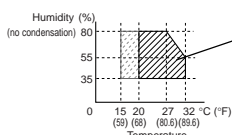

We recommend use in an operating environment within the range shown by solid lines.

8-2 Usable Media

Use genuine media for this machine.

A) Cuttable media thickness

0.08 to 0.22 mm (0.00315 to 0.00866 in.)
(depending on media composition)

B) Maximum media thickness including backing paper

Printing only: 1.0 mm (0.039 in.)
When performing cutting: 0.4 mm (0.0157 in.)

C) Maximum outer diameter of roll media

180 mm

D) Core inner diameter for roll media

50.8 mm (2 in.) or 76.2 mm (3 in.)

E) Maximum weight for roll media

12 kg (26 lb.)

F) Roll-method conditions

- Outward curl (printed surface on outer side)
- Beginning of media curl not attached to paper tube (core)

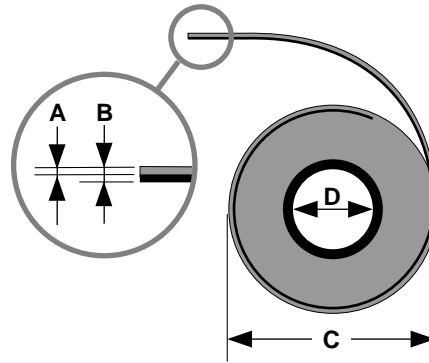

Side view of roll media

8-3 Printing or Cutting Area

Maximum Area

The printing or cutting area along the horizontal plane (the direction in which the carriage moves) is determined by the position of the pinch rollers. The workable area spans the length between the two rollers, minus a margin of approx. 1.5 mm (approx. 0.06 in.) on both sides.

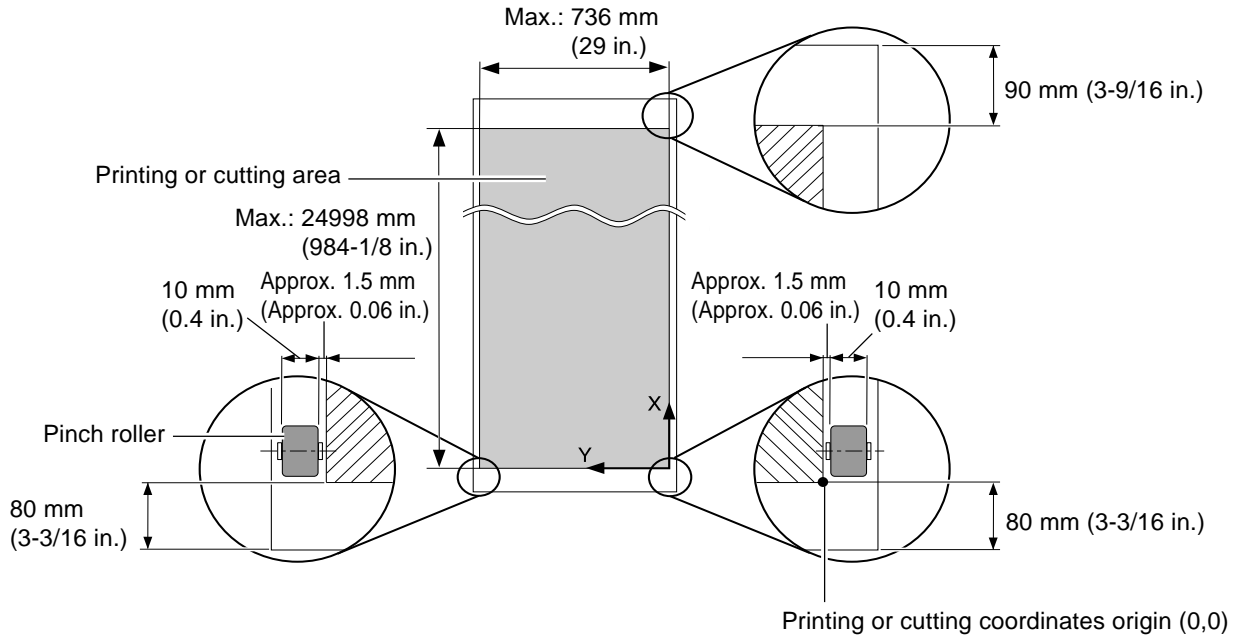

Area When Using Crop Marks

When crop marks are used, the printing or cutting area is reduced from the maximum area by an amount equal to the crop marks.

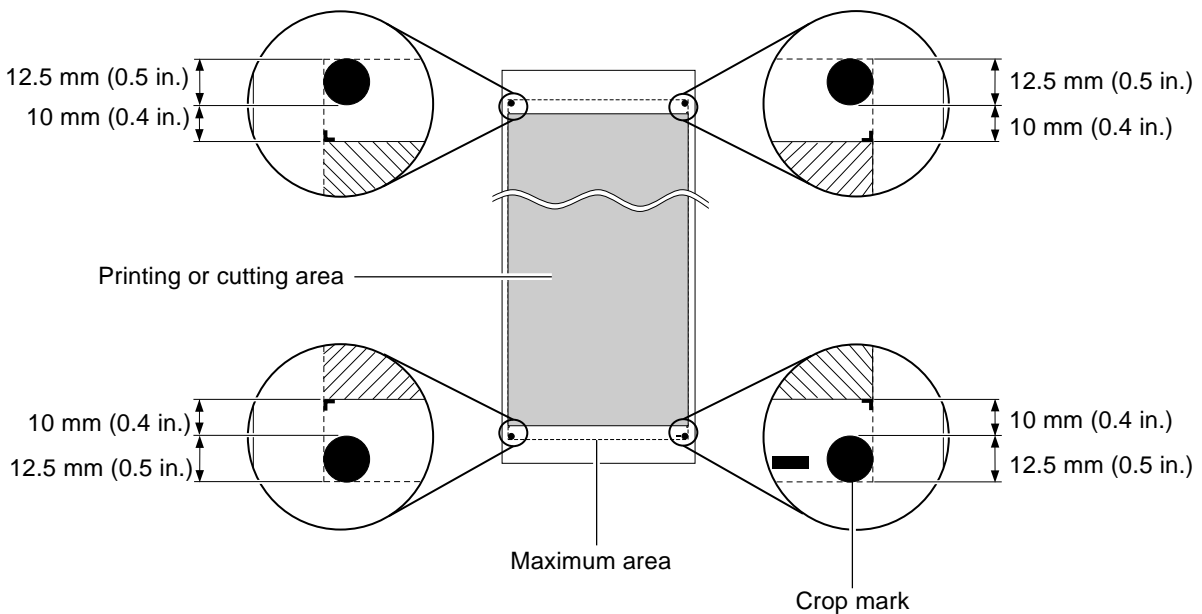

The Media-cutoff Location During Continuous Printing

The media-cutoff location that is used when a media-cutoff command is sent from the computer is determined as follows.

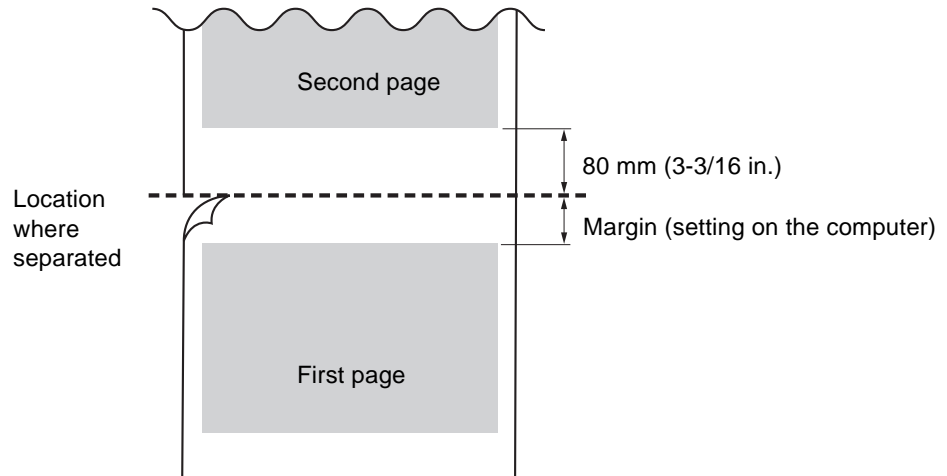

8-4 About Blade Life

Cutting conditions and blade life vary according to the hardness of the media and the usage environment. Making the settings for the conditions described below does not automatically guarantee attractive cutting results in all situations. Before performing actual cutting, be sure to carry out a cutting test and make any necessary adjustments. (See "3-1 Points to Check Before Performing Output.")

If the media is not cut through completely even when the tool force is increased by 50 to 60 gf more than the tool force values shown below, it means that the useful life of the blade has ended. Replace with a new blade.

Blade	Media	Tool-force	Amount of cutter offset	Life of a blade (General guide)
ZEC-U1005	General Signage Vinyl	50 to 150 gf	0.25 mm	8000 m
ZEC-U5025	General Signage Vinyl	30 to 100 gf	0.25 mm	4000 m
	Fluorescent Vinyl	120 to 200 gf	0.25 mm	4000 m
	Reflective Vinyl	100 to 200 gf	0.25 mm	4000 m

* The values for the life of a blade are intended to serve as a general guide when cutting media of identical type.

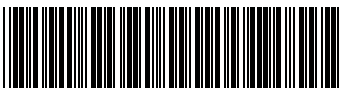

26015442-R4

R4-040610