

BY-20

User's Manual

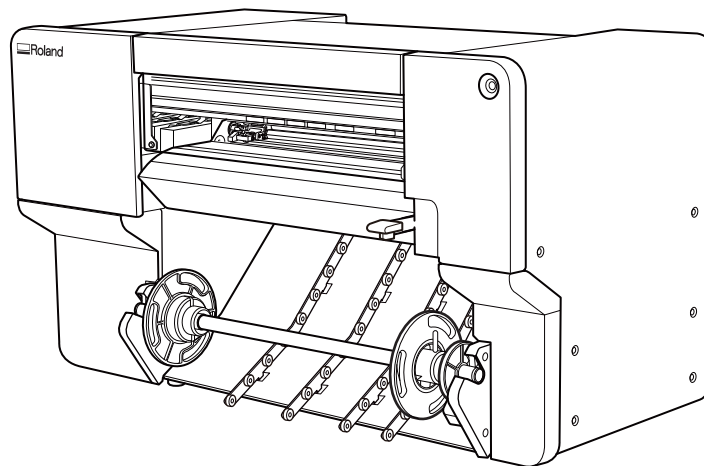

Thank you very much for purchasing this product.

- To ensure correct and safe usage with a full understanding of this product's performance, please be sure to read through this manual completely.
- Unauthorized copying or transferal, in whole or in part, of this manual is prohibited.
- The specifications of this product and the contents of this operation manual are subject to change without notice.
- The operation manual and the product have been prepared and tested as much as possible. If you find any misprints or errors, please inform us.
- Roland DG Corporation assumes no responsibility for any direct or indirect loss or damage that may occur through use of this product, regardless of any failure to perform on the part of this product.
- Roland DG Corporation assumes no responsibility for any direct or indirect loss or damage that may occur with respect to any article made using this product.

Contents

Basic Handling Methods	7
Basic Information	8
Introduction	9
Part Names and Functions.....	9
System Configuration Diagrams	14
About This Manual	14
Starting/Exiting Utility.....	15
Starting Utility	15
Exiting Utility	15
Utility Home Screen	16
Menu List.....	18
About the Media Used.....	27
Media type.....	27
Usable Media	27
Four Different Output Methods	28
Important Points During Use	28
Printing-start Location	29
Basic Operations.....	30
Power Supply Operations	31
Turning the Power On	31
Turning the Power Off (Sub-power Off)	34
Precautions When Operating the Power Supply.....	36
Sleep Mode (Power-saving Feature)	36
Setup of New Media	37
Setup of Roll Media.....	37
Setup of Sheet Media	53
Setup of Registered Media.....	63
Setup of Roll Media.....	63
Setup of Sheet Media	78
Checking before Output	86
LAN (Local Area Network) Settings	86
Preventing Sedimentation in Inks	86
Pausing and Canceling Output	88
Pausing and Resuming Output	88
Canceling Output	89
Separating the Media.....	91
Output Method	93
Printing Method.....	94
Preparations for Output	95
Step 1: Performing a Nozzle Drop-out Test	95
Step 2: Normal Cleaning Method	97
Starting Print Output.....	99
Cutting Method	101
Preparations for Output	102
Step 1: Switching Off the Print Heater and Dryer	102
Step 2: Preventing Pulling of the Media with Undue Force	103
Step 3: Adjusting Cutting.....	104
Starting Print Output.....	106
Printing and Cutting Method.....	108

Preparations for Output	109
Step 1: Performing a Nozzle Drop-out Test	109
Step 2: Normal Cleaning Method	111
Step 3: Adjusting Cutting.....	113
Step 4: Correcting the Misalignment of Printing and Cutting	115
Starting Print Output	117
How to Cut with Crop Marks	119
Preparations for Output with Crop Marks	120
Step 1: Performing a Nozzle Drop-out Test	120
Step 2: Normal Cleaning Method	122
Step 3: Adjusting Cutting.....	124
Step 4: Correcting the Misalignment of Printing and Cutting with Crop Marks	126
Starting Output with Crop Marks	128
Preparations for Cutting Output.....	130
Step 1: Setting Up Media with Crop Marks.....	130
Step 2: Switching Off the Print Heater and Dryer	131
Step 3: Preventing Pulling of the Media with Undue Force	132
Starting Cutting Output.....	133

Optimizing Quality and Efficiency 134

Optimizing the Output Quality	135
Using the Correction Functions	136
Automatically Making Required Adjustments	136
Manual Adjustment: Reducing Horizontal Bands (Feed Correction)	138
Manual Adjustment: Adjusting the Misalignment of the Ink Landing Position (Media Gap Adjustment)	140
Configuring Settings to Match the Properties of the Media	142
Using Hard-to-Dry Media	142
Using Media That Wrinkles Easily/Does Not Move Smoothly	143
Using Sticky Media.....	144
Preventing Ink Discharge Issues.....	145
Preventing Soiling of the Media, Dot Drop-out, and Dot Displacement	145
Adjusting the Ink-drying Method	147
What Is the Media Heating System?.....	147
Setting the Print Heater Temperature	149
Setting the Dryer Temperature.....	151
Hints and Tips for Temperature Control	153
Setting the Temperature during Standby	154
Drying the Trailing Edge of the Printing Area on the Dryer	155
Accurately Adjusting the Cutting Settings	157
Fine-tuning the Cutting Conditions	157
Adjusting the Amount of Blade Extension	159
Performing Distance Correction during Cutting.....	160
Cutting to Make It Possible to Cut Corners Attractively (Over Cut)	161
Accurately Adjusting the Settings for Printing and Cutting	163
Correcting the Misalignment of Printing and Cutting	163
Accurately Adjusting the Settings for Cutting with Crop Marks	167
Correcting the Misalignment of Printing and Cutting with Crop Marks (Crop Cut Position Adjustment [Media Not Removed]).....	167
Correcting the Misalignment of Printing and Cutting with Crop Marks (Separate Test for Printing and Cutting with Crop Marks [Media Removed]).....	172
Correcting the Reading Sensor (Multi Sensor Adjustment)	179
Optimizing Work Efficiency	180
Managing the Media Settings.....	181
Changing the Media Settings.....	181
Checking the Registered Media Settings	183

Changing the Media Name	185
Duplicating Media Settings	186
Deleting Media Settings	188
Adjusting the Output-start Location	189
Setting the Base Point	189
Reducing Output Time	192
Speeding Up Output for Narrow Media	192
Other Functions	193
Adjusting the Right Media Clamp Position	193
Performing Printing Tests Arranged Horizontally	194
Optimizing Operation Management	195
Managing the Operations Appropriately and Efficiently	196
Checking the Remaining Media	196
Printing the Amount of Remaining Media	198
Setting the Activation Interval for Sleep Mode (Power-saving Feature)	199
Setting the Duration of the Warning Beep	200
Managing the Basic Settings of the Printer	201
Changing the Units of Measurement	201
Viewing Printer Information	202
Viewing Network Information	203
Changing the Network Settings	204
Returning Adjustments to Their State Prior to the Initial Settings	212
Resetting All Adjustments to Factory Default Values	213

Maintenance214

Introduction	215
Important Notes on Handling and Use	216
Printer Unit	216
Ink Cartridges	216
Basic Maintenance Knowledge	217
Automatic Maintenance Feature and Notes	217
Types and Timing of Maintenance	217
When Not in Use for a Prolonged Period	218
Regular Maintenance	219
Maintenance of Ink Cartridges (White Ink Only)	220
Start-up Cleaning	221
Start-up Cleaning Methods	222
Print Head Check before Printing	224
Cleaning the Machine	225
Daily Shut-down Cleaning	226
Daily Shut-down Cleaning Methods	226
Disposing of Discharged Fluid	228
About Care and Maintenance of the Print Heads	232
Advanced Maintenance	233
Periodical Cleaning Maintenance	234
Medium Cleaning	234
Powerful Cleaning	236
Handling Severe Dot Drop-out	238
Replacing Consumable Parts	239
Replacing Ink Cartridges	240
Out-of-ink Warnings	240
Replacing Ink Cartridges	241

Replacing Parts for Maintenance	243
Replacing the Wiper.....	243
Replacing the Felt Wiper	245
Replacing the Wiper Pad	246
Replacing the Blade	248
Replacing the Separating Knife.....	250
Replacing the Cap Top	252

Troubleshooting Methods.....254

Output Quality Problems	255
Printed results are coarse or contain horizontal stripes	256
Do the Print Heads Show Nozzle Drop-Out?	256
Have you carried out [Feed Correction]?	256
Have you carried out [Media Gap Adjustment]?	256
Is the temperature of the room too low?	257
Is the printer installed in a level and stable location?.....	257
Is the media heating system at a suitable temperature?.....	257
Is the printer installed in a location out of direct sunlight?	257
Is the media loaded and set up correctly?.....	257
Colors are unstable or uneven	258
Did you shake the ink cartridges before installing them?	258
Is the media wrinkled?.....	258
Was printing paused partway through?.....	258
Is the printer installed in a level and stable location?.....	259
Is the printer being used in a location subject to severe changes in the operating environment?	259
Is the media loaded and set up correctly?.....	259
The media becomes soiled when printed	260
Are the print heads dirty?	260
Are the pinch rollers or the media clamps dirty?.....	260
Cutting is misaligned or skewed	261
Is the media loaded and set up correctly?.....	261
Are the settings for the cutting conditions appropriate?.....	261
Is the length of output too long?.....	261
Are you using media that exhibits large expansion and contraction?	261
Is the setting for the [Cutting Distance Correction] menu item (under [List of Media Settings]) correct?.....	261
Have you corrected the misalignment of printing and cutting?	262
Is the cutting tool installed appropriately?.....	262
Is the blade worn?	262
Is there any buildup of pieces of media or dust inside the blade holder?	262
The printed surface is damaged when cutting	263
Does the tip of the blade holder cap scrape the printed surface?.....	263
Problems in Cutting with Crop Marks	264
Automatic Detection of Crop Marks Fails	265
Is the media wrinkled or warped?	265
Is the media size too large?.....	265
Are you using media that is likely to reflect light?.....	265
Are you using transparent media?	265
Printing and Cutting Are Misaligned.....	266
Have you corrected the misalignment of printing and cutting with crop marks?	266
Media Feed Problems	267
Media Wrinkles or Shrinks	268
Is the media loaded securely and straight?.....	268
Was loaded media allowed to stand for some time?	268
Are the media clamps installed?	268
Was the media loaded while the print heater was hot?	268

Is the temperature of room too low?	268
Is the humidity of the room too high?	268
Is the using media deflected?	268
Media Feed Is Not Straight	269
Is the media loaded securely and straight?	269
Media Feed Is Not Smooth	270
Is some other object coming into contact with the media?	270
Is the media too thick?	270
Are the grit rollers dirty?	270
A Media Jam Occurs!	271
Is an error message displayed?	271
Is the media warped or wrinkled?	271
Are the grit rollers dirty?	271
Are the media clamps installed?	271
Is the media loaded securely and straight?	271
Is some other object coming into contact with the media?	271
Is the media too thick?	272
Is the machine's installation site appropriate?	272
Is the machine on a table of the recommended size?	272
Machine Problems	273
Why Has the Print-Head Carriage Stopped Moving?	274
What to Do First	274
If the Print Heads Still Do Not Move	274
The Printer Unit Doesn't Run	276
Is the power switched on?	276
Is [Output possible.] displayed in the Utility window?	276
Are any covers open?	276
Is the message [Output is currently paused.] displayed in the Utility window?	276
Is a message displayed in the Utility window?	276
Is an [Ink Cartridge Error] displayed?	276
Are the cables connected?	277
The Media Heating System Doesn't Warm Up	278
Has the media been set up?	278
Is the temperature of the room too low?	278
Cannot Separate the Media	279
Are the separating knife and media clamps attached?	279
Handling Messages and Error Messages	280
Messages	281
[When output, cleaning, and other operations are completed, discard the discharged fluid.]	281
[The time for Daily shut down cleaning has arrived.]	281
[The time for wiper replacement has arrived.]	281
[The time for felt wiper replacement has arrived.]	281
[Print head protection mode has activated.]	281
[High-temperature alert]	281
Error Messages	283
[Ink Cartridge Error]	283
[Cover Open Error]	283
[Media End Error]	283
[Loading Lever Error]	284
[Media Loading Error]	284
[Replace the drain pack.]	284
[Crop Mark Detection Error]	285
[Pinch Roller Error]	285
[Insufficient Media Width]	285
[Media clamps could not be detected.]	286
[The connection to the unit was lost.]	286
[Motor Error]	286

[Print Head Dry-out Error] 287
[Low Temperature Error] 287
[High Temperature Error] 287
[Pump Stop Error] 288
[Cleaning Error] 288
[Service Call] 288

Appendix.....289

Operations When Moving the Unit290
 Preparing to Move the Machine 291
 Procedures from Preparing to Move to Reinstallation 291

Main Specifications296
 Printing Area 297
 Maximum Area 297
 Maximum Area When Using Crop Marks 298
 Media Separation Location during Continuous Printing 299
 About the Blade 300
 Specifications..... 301

Basic Handling Methods

Basic Information

Introduction	9
Part Names and Functions	9
System Configuration Diagrams	14
About This Manual.....	14
Starting/Exiting Utility	15
Starting Utility	15
Exiting Utility	15
Utility Home Screen.....	16
Menu List	18
About the Media Used	27
Media type	27
Usable Media	27
Four Different Output Methods.....	28
Important Points During Use.....	28
Printing-start Location.....	29

Introduction

Part Names and Functions

Front

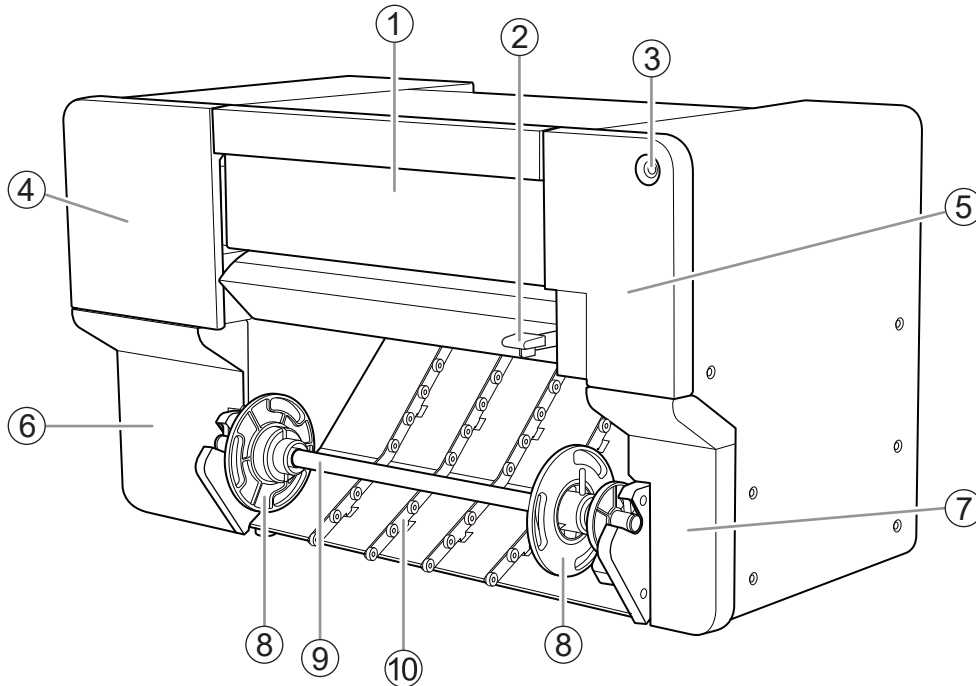

No.	Name	Function overview
①	Front cover	Prevents contact with the print-head carriage and other such fast-moving parts when the machine is operating. This cover also prevents dust from entering the machine. Keep this cover closed when not loading media or performing maintenance.
②	Loading lever	Secures the media in place and releases it. Lowering this lever secures the media in place.
③	Sub power button	Switches the sub power of the machine on/off.
④	Left cover	Provides access to the interior of the upper-left side of the machine. Open this cover when performing maintenance such as replacing ink cartridges and cleaning around the print heads.
⑤	Right cover	Provides access to the interior of the upper-right side of the machine. Open this cover when performing maintenance such as cleaning and part replacement.
⑥	Lower-left cover	Provides access to the interior of the lower-left side of the machine, where maintenance supplies and similar items are stored.
⑦	Lower-right cover	Provides access to the interior of the lower-right side of the machine. Open this cover when performing maintenance such as drain pack replacement.
⑧	Media flange	Hold the roll media. Fit the paper tube of the media onto the media flanges of the media holders.

Introduction

No.	Name	Function overview
⑨	Shaft	Holds the media flanges. The left media flange is moved to the left or right along this shaft to match the width of the media.
⑩	Media feed rollers	Reduce the contact resistance when there is slack in the media such as during media pullback.

Inside the Cover

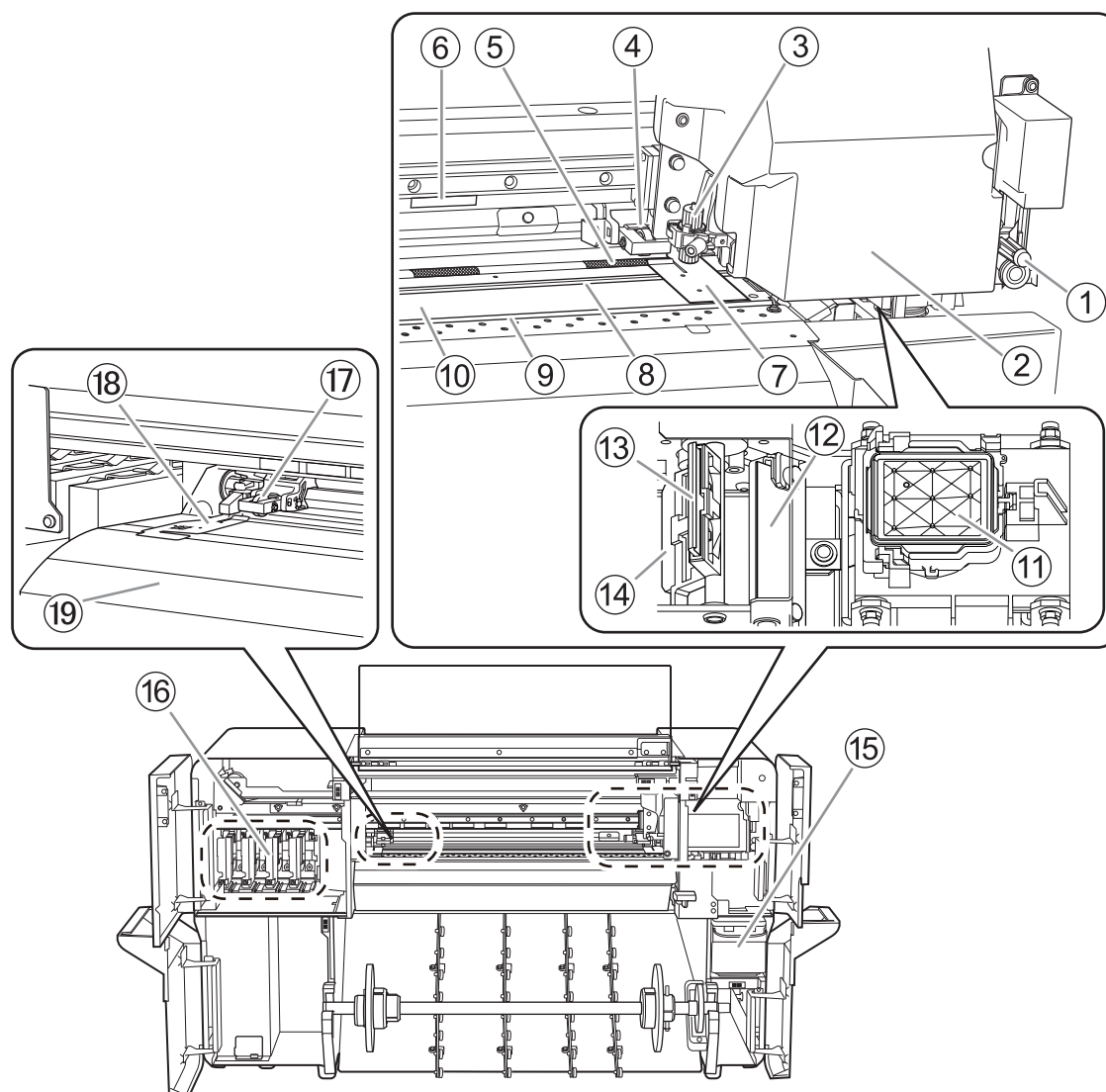

No.	Name	Function overview
①	Replacement blade for separating knife	The knife used to separate the media.
②	Print-head carriage	Transports the built-in print heads, blade, and separating knife to the left and right.
③	Blade holder	Holds the blade used during cutting.
④	Right pinch roller	Each pinch roller is lowered/raised according to the operation of the loading levers. Lowering a loading lever lowers the pinch rollers, clamping the media. You can move this roller to the left and right within the range of the right-edge grit roller.
⑤	Grit roller	Transports the media.
⑥	Grit pattern	Indicates the positions in which the left pinch roller can be positioned. When loading media, be sure to place the left pinch roller within the range indicated by this pattern.
⑦	Right media clamp	Holds down the right edge of the media, keeping the media from coming loose and preventing fuzz on the cut edge of the media from touching the print heads.

Introduction

No.	Name	Function overview
⑧	Blade protector	This is the path that the blade takes during cutting. It protects the tip of the blade.
⑨	Separating groove	The path for the separating knife during sheet cutting.
⑩	Platen	This is the path over which the media passes. A suction fan that keeps the media from coming loose and a print heater that helps fix the ink are built in.
⑪	Cap top	Prevents the print heads from drying out by sealing the print heads to protect the ink emission surface when the print-head carriage is at the right side of the machine, such as when waiting for printing.
⑫	Scraper	Removes ink and dirt that have adhered to the wiper.
⑬	Wiper	Cleans the print heads, removing dirt and excess ink that have adhered to these heads.
⑭	Felt wiper	Cleans the edges of the print heads after wiper operation, suctioning dirt and excess ink that remain on these edges.
⑮	Drain cartridge	Accumulates the discharged ink. If the drain pack in this cartridge is full of discharged fluid, a message prompting you to replace the pack will appear in the Utility window. If this message appears, replace the drain pack in the drain cartridge.
⑯	Ink slots	Store the ink cartridges.
⑰	Left pinch roller	Each pinch roller is lowered/raised according to the operation of the loading levers. Lowering a loading lever lowers the pinch rollers, clamping the media. Position this roller within the range of the grit pattern.
⑱	Left media clamp	Holds down the left edge of the media, keeping the media from coming loose and preventing fuzz on the cut edge of the media from touching the print heads.
⑲	Apron	This has a built-in dryer to speed up drying of the ink.

Left Side

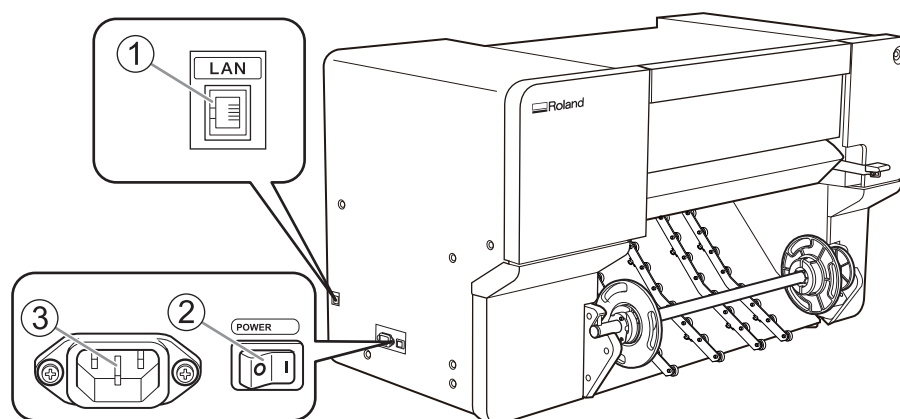

No.	Name	Function overview
①	Ethernet connector	Use this to connect an Ethernet cable.
②	Main power switch	Switches the main power of the machine on/off.
③	Power-cord connector	Used to connect the power cable from which power is supplied to the machine.

Machine State Indicated by the Sub Power Button's LED Lamp

The machine states are indicated with LED lamp colors and flashing patterns. The LED lamp allows you to check the state of the machine at a distance.

LED lamp state	Machine state
Off	The power is off.
Lit in yellow	The media setup is complete and output is possible.
Flashing in yellow	The machine is paused, or heater warm up is in progress.
Lit in green	Printing or cutting output is in progress.
Lit in blue	Media has not been set up, such as during maintenance operations.
Flashing in blue	The machine is in sleep mode or is being turned off.
Lit in red	An abnormality has occurred in the machine.

System Configuration Diagrams

The image below shows the data flow from creating a design in Roland DG Connect Designer to printing on the machine.

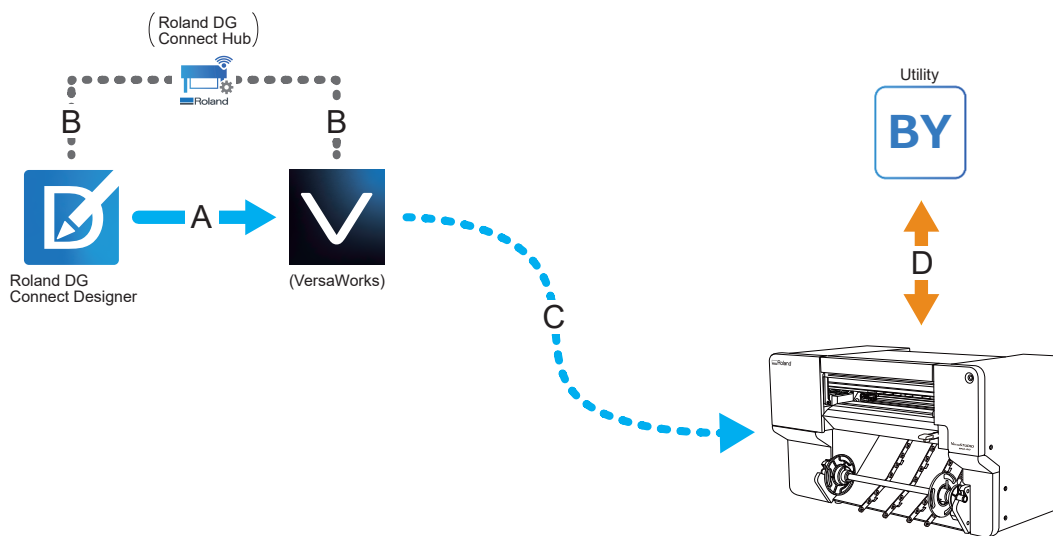

A	Drafting data transmission
B	Drafting data transmission support
C	Printing data transmission
D	Operating and setting the machine

About This Manual

Some images in this manual show the BN2-20/20A, but the details are the same for this machine.

Starting/Exiting Utility

Starting Utility

Procedure

1. Start Roland DG Connect Hub.

- Windows 11 (version: 24H2)
Click [Start]>[All apps], and then click [Roland DG Connect Hub].
- Windows 10 (version: 22H2)
Click [Start], and then click [Roland DG Corporation]>[Roland DG Connect Hub].
- Mac (macOS 15.1)
Click the [Roland DG Connect Hub] icon on the Dock.

2. Select the machine to use.

The applications that can be used with the selected machine are displayed at the bottom of the window.

3. Click [Open] next to Utility.

The Utility home screen appears.

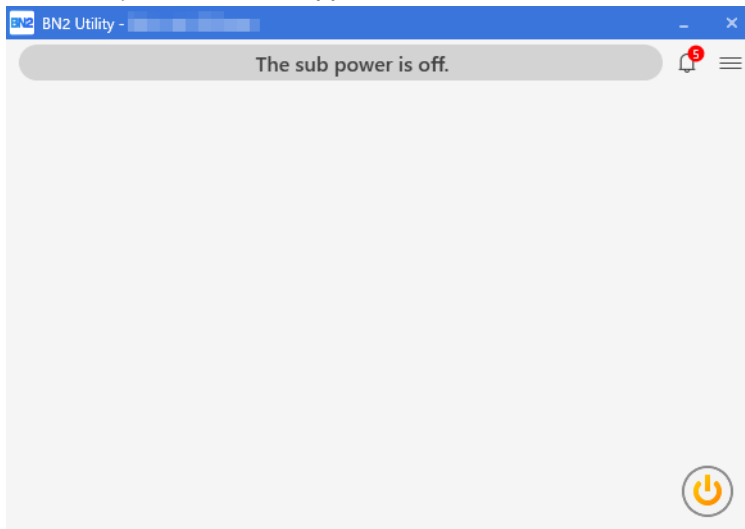

Exiting Utility

Procedure

1. Click  in the upper-right corner of the Utility window.

This exits the utility.

Utility Home Screen

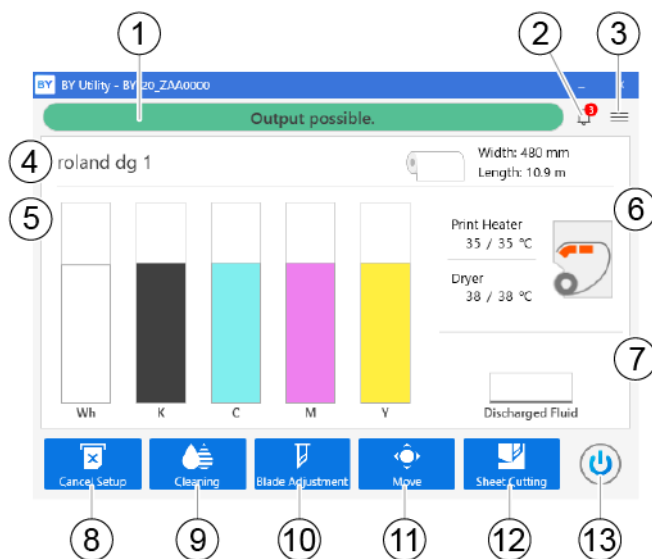

No.	Name	Details
①	Status bar	Displays the printer status and indicates the next operation.
②	Notifications	Displays important information. When there are notifications, their number is displayed next to the icon.
③	Menu	Displays various setting menus.
④	Media information	Displays media information. When media is set up, the media name, printable width, and amount of media remaining*1 are displayed.
⑤	Amount of ink remaining	Displays the amount of ink remaining in each cartridge. If it is time to replace a color,  is displayed next to the corresponding ink cartridge. Click this icon to display the detailed information for the ink.
⑥	Heater Temperature	The print heater and dryer temperatures are displayed as current temperature/set temperature. Click one of these items to display a screen for: <ul style="list-style-type: none"> Turning [Print Heater] on/off and setting its temperature. Turning [Dryer] on/off and setting its temperature.
⑦	Discharged Ink	Displays the amount of discharged fluid in the drain pack.
⑧	[Setup]/[Cancel Setup]	Starts/cancels the setting up of the media. <ul style="list-style-type: none"> • Setup of New Media(P. 37) • Setup of Registered Media(P. 63)
⑨	[Cleaning]	Displays the menu related to the printing test and cleaning for the nozzle drop-out check.
⑩	[Blade Adjustment]	Sets cutting conditions. This is only enabled when media has been set up.
⑪	[Move]	Feeds the media and moves the print-head carriage. You can also set the position moved to as the right edge of the output area (the base point). Setting the Base Point(P. 189)

No.	Name	Details
⑫	[Sheet Cutting]	Activates the separating knife to separate the media. You can also specify perforation.
⑬	Sub power	Operates the sub power of the machine.

*1 This information is only displayed when media has been set up and the amount of media remaining has been set.

Menu List

Click  to display the [Menu] window.

List of Media Settings

This window displays the setting information of the media that has been set up. This window is not displayed if the media has not been set up.

You can check, change, and adjust the settings made when the media was registered.

Click [Batch Automatic Correction] to carry out the following adjustments and corrections.

- Multi sensor adjustment
- Feed correction: simple correction (auto)
- Media gap adjustment: simple correction (auto)

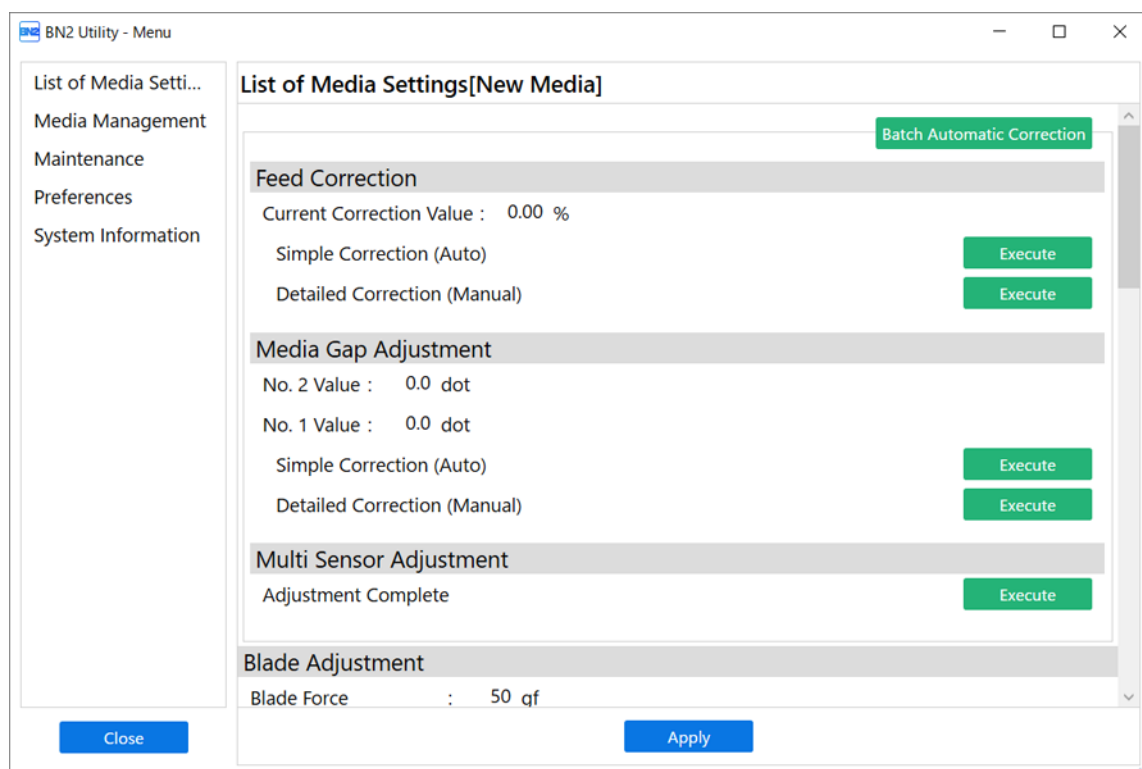

Feed Correction

This correction value is used to make the band-shaped "stripes" on the printed surface less noticeable. To change the current correction value, click [Execute].

- Simple Correction (Auto)
Performs automatic correction with the multi sensor.
- Detailed Correction (Manual)
Allows you to visually check the test results to determine and enter the correction values.
For more information, refer to [Manual Adjustment: Reducing Horizontal Bands \(Feed Correction\)](#).

Media Gap Adjustment

These correction values eliminate ink landing position misalignment due to the print head height or the media thickness.

To change the current correction value, click [Execute].

- **Simple Correction (Auto)**
Performs automatic correction with the multi sensor.
- **Detailed Correction (Manual)**
Allows you to visually check the test results to determine and enter the correction values.
For more information, refer to [Manual Adjustment: Adjusting the Misalignment of the Ink Landing Position \(Media Gap Adjustment\)](#).

Multi Sensor Adjustment

The multi sensor is used when reading crop marks and with the automatic correction function. If **[Not Adjusted]** is displayed or to perform adjustment again, click **[Execute]**.

Blade Adjustment

Displays the current blade settings.

To perform adjustment again, click **[Execute]**.

For more information, refer to [Fine-tuning the Cutting Conditions](#).

Print & Cut Position Adjustment

These correction values eliminate misalignment of the printing and cutting positions.

To perform adjustment again, click **[Execute]**.

For more information, refer to [Step 4: Correcting the Misalignment of Printing and Cutting](#).

Crop Cut Position Adjustment

These correction values eliminate cutting position misalignment when reading crop marks and cutting.

To perform adjustment again, click **[Execute]**.

- **Crop Cut Position Adjustment [Media Not Removed]**
For more information, refer to [Correcting the Misalignment of Printing and Cutting with Crop Marks \(Crop Cut Position Adjustment \[Media Not Removed\]\)](#).
- **Separate Test for Printing/Cutting with Crop Marks [Media Removed]**
For more information, refer to [Correcting the Misalignment of Printing and Cutting with Crop Marks \(Separate Test for Printing and Cutting with Crop Marks \[Media Removed\]\)](#).

Cutting Distance Correction

These correction values eliminate differences in the length of the cutting line set with the data and the length that is actually cut.

The cutting distance correction values can be changed.

For more information, refer to [Performing Distance Correction during Cutting](#).

Over Cut

Displays the over cut setting.

Cutting the corners of the border of the cutting line slightly longer makes it possible to cut the corners attractively.

You can enable/disable over cutting.

For more information, refer to [Cutting to Make It Possible to Cut Corners Attractively \(Over Cut\)](#).

Heater Temperature

Displays the current print heater and dryer settings.

The main roles of the print heater and dryer are as follows:

- Preventing loose media
- Improving ink adhesion

- Preventing ink blurring
- Drying the ink

You can turn the print heater and dryer on/off and change their temperatures.

For more information, refer to [Adjusting the Ink-drying Method](#).

Dry After Printing

Displays the current settings for drying after printing.

These settings are used to feed the media to the dryer after printing, facilitating the drying of the ink.

You can enable/disable the drying feed and change the drying time.

For more information, refer to [Drying the Trailing Edge of the Printing Area on the Dryer](#).

Drying Time Per Scan

Displays the current setting for the drying time per scan.

Sets the drying time per scan operation of the print-head carriage during printing.

You can change the drying time per scan.

For more information, refer to [Using Hard-to-Dry Media](#).

Media Suction Force

Displays the current Media Suction Force.

You can change the settings of the media suction fan.

For more information, refer to [Using Media That Wrinkles Easily/Does Not Move Smoothly](#).

Printing Movement Range

Displays the current Printing Movement Range.

You can change the movement range of the print-head carriage during printing to match the media or the output data.

For more information, refer to [Reducing Output Time](#).

Media Sticking Prevention

Displays the current setting.

You can change the setting to match the characteristics of the media.

For more information, refer to [Using Sticky Media](#).

Media Management

Displays a list of registered media. Up to 50 media names can be saved.

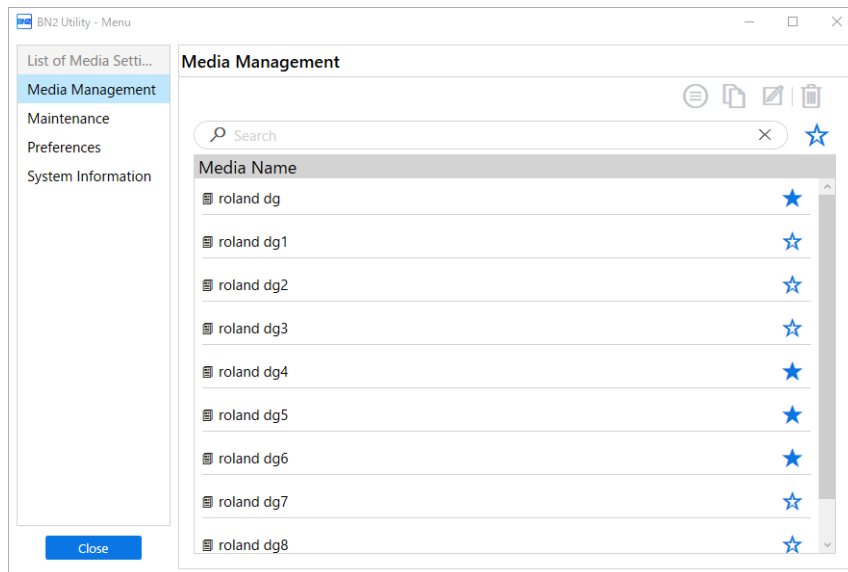

You can view, duplicate, delete, and perform other operations on the details set for the registered media.

: Display Media Settings

Displays the details set for the registered media.

: Duplicate Media

Duplicates details set for the registered media, registering the duplicate as separate media.

: Change Media Name

Changes the name of the registered media.

: Delete Media

Deletes the registered media that is selected.



: View Procedure Videos

You can view reference videos on how to set up your media.

We recommend that you view these videos to understand the overall flow of work.

Search Function and Favorites Function

You can search for a media name with the search box. Furthermore, you can set commonly used media as favorites and display only these favorites. You can also search while favorites are displayed.

1. Click  next to a media name to change this icon to .
2. Click  next to the search box.

The icon changes to , and the list of media set as favorites appears.

Click  again to display the list of all media.

Maintenance

Use this window to replace consumable parts and perform other machine maintenance.

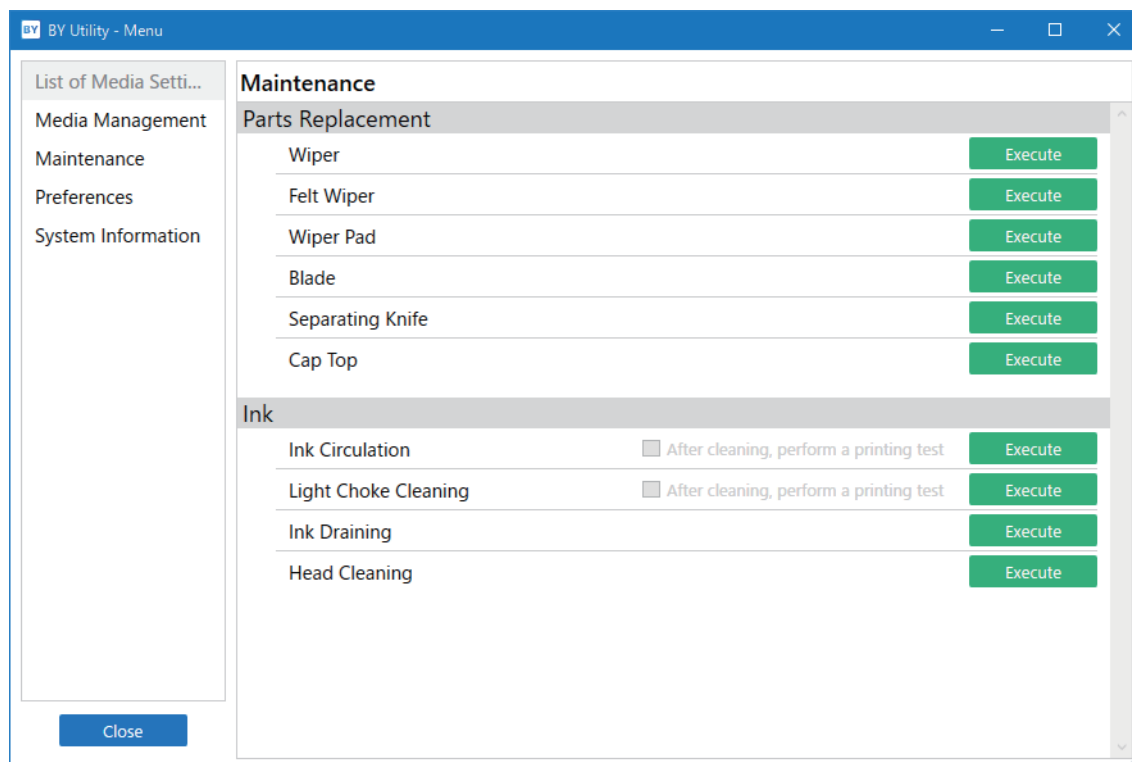

Wiper

Click **[Execute]** to switch to **[Wiper Replacement]** execution screen. Follow the on-screen instructions to replace the wiper.

For more information, refer to [Replacing the Wiper](#).

Felt Wiper

Click **[Execute]** to switch to **[Felt Wiper Replacement]** execution screen. Follow the on-screen instructions to replace the felt wiper.

For more information, refer to [Replacing the Felt Wiper](#).

Wiper Pad

Click **[Execute]** to switch to **[Wiper Pad Replacement]** execution screen. Follow the on-screen instructions to replace the wiper pad.

For more information, refer to [Replacing the Wiper Pad](#).

Blade

Click **[Execute]** to switch to **[Blade Replacement]** execution screen. Follow the on-screen instructions to replace the blade.

For more information, refer to [Replacing the Blade](#).

Separating Knife

Click **[Execute]** to switch to **[Separating Knife Replacement]** execution screen. Follow the on-screen instructions to replace the separating knife.

For more information, refer to [Replacing the Separating Knife](#).

Cap Top

Click **[Execute]** to switch to **[Cap Top Replacement]** execution screen. Follow the on-screen instructions to replace the cap top.

For more information, refer to [Replacing the Cap Top](#).

Ink

- **Ink Circulation**

Circulates ink to prevent uneven color issues with white ink.

Click **[Execute]** to display the **[Ink Circulation]** window.

MEMO

If the media has already been set up, the **[After cleaning, perform a printing test]** menu appears. When this is turned on, a printing test is performed after cleaning.

- **Light Choke Cleaning**

Performs cleaning to improve uneven color issues with ink and severe dot drop-out.

Click **[Execute]** and check the remaining amount of white ink. Then, click **[OK]** to start **[Light Choke Cleaning]**.

When there are uneven color issues with ink

Perform **[Light Choke Cleaning]** if uneven color issues are not improved by carrying out the following operations in order: ink mixing, **[Ink Circulation]** (only when uneven color issues with white ink occur), and **[Powerful Cleaning]**.

When there is severe dot drop-out

When ink discharge issues such as dot drop-out are not resolved even after you perform normal, medium, and powerful cleaning, perform **[Light Choke Cleaning]**.

IMPORTANT

Light choke cleaning consumes a lot of ink, and overly frequent use may damage the print heads themselves. Avoid performing this operation more than necessary.

MEMO

If the media has already been set up, the **[After cleaning, perform a printing test]** menu appears. When this is turned on, a printing test is performed after cleaning.

- **Ink Draining**

Drains the ink from the machine so ink does not leak when the machine is tilted, such as when it is moved. Ink drying in the ink paths may damage the print heads, leading to malfunctions. Fill the machine with ink as soon as possible after the machine is moved.

Click **[Execute]** to switch to **[Ink Draining]** execution screen. Follow the on-screen instructions to drain the ink.

- **Head Cleaning**

Perform this maintenance before moving the machine.

The ink will be drained from the machine, and the ink paths will be cleaned with cleaning liquid.

Click **[Execute]** to switch to **[Head Cleaning]** execution screen. Follow the on-screen instructions to execute the head cleaning.

For more information, refer to [Operations When Moving the Unit](#).

Preferences

Change the operation settings of the machine to match the usage environment.

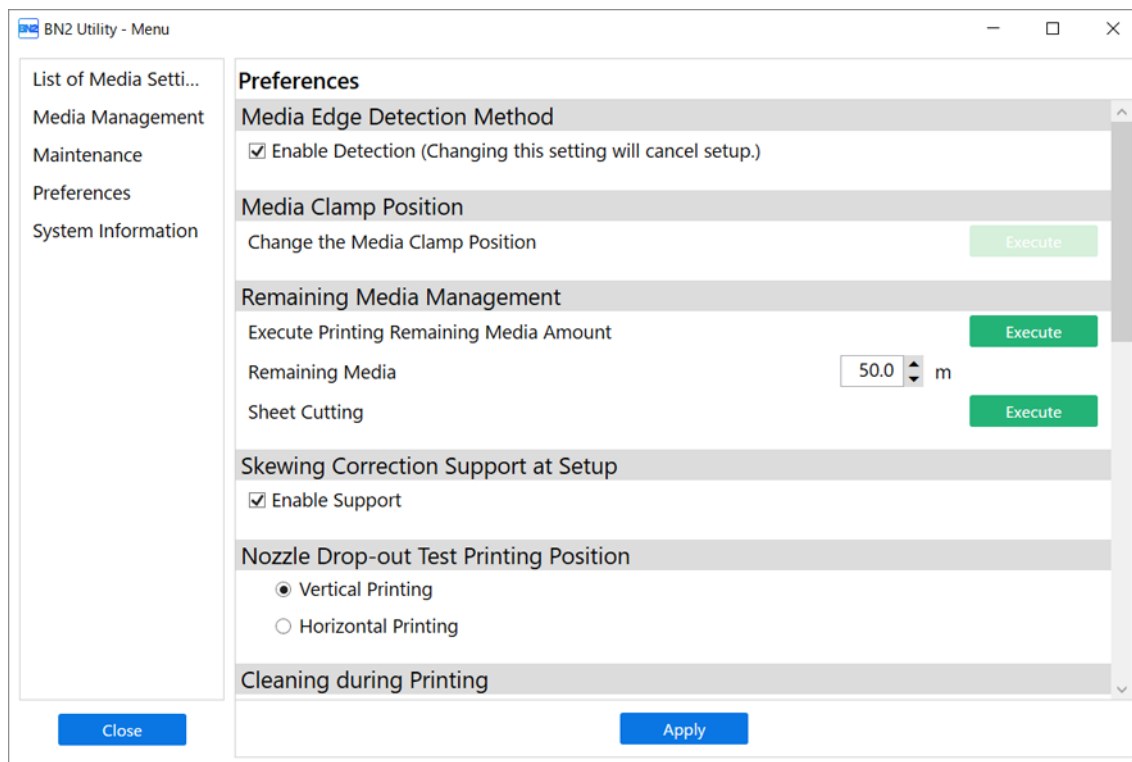

Media Edge Detection

Sets whether to detect the leading and trailing edges of the media. When using transparent media, whose edges cannot be detected, clearing this check box makes it possible to set up the media without detecting the edges.

Media clamp position

This menu is used to change the right media clamp position when loading media on the machine. This item cannot be used when media has been set up.

Click [Execute] to move the print-head carriage to the left, allowing you to adjust the right media clamp position.

For more information, refer to [Adjusting the Right Media Clamp Position](#).

Remaining Media Management

When you set the amount of remaining media that has been set up, this amount is displayed on the Utility home screen.

Click [Execute] next to [Execute Printing Remaining Media Amount] to print the amount of remaining media.

Skewing Correction Support at Setup

Selecting this check box provides support, preventing skewed installation of the media by making a sound and operating an automatic suction fan during setup.

Nozzle Drop-out Test Printing Position

Sets the direction for test pattern printing: [Vertical Printing] or [Horizontal Printing].

Cleaning during Printing

Selects the frequency of cleaning during printing from the following options.

- **[No Cleaning]**
Automatic cleaning during printing is not performed.
- **[Every Page]**
Automatic cleaning is performed each time prior to the start of printing.
- **[Periodically (Job Priority)]**
Automatic cleaning is performed prior to the start of the next printing operation, and cleaning during printing is not performed.
- **[Periodically (Time Priority)]**
Automatic cleaning is performed when the cumulative printing time reaches the value you set here.

If you select **[Periodically (Job Priority)]** or **[Periodically (Time Priority)]**, set the interval from the previous cleaning operation to the next cleaning operation.

Standby Heater Temperature

Sets the heater temperature when media has not been set up.

Prefeeding at Output

If you select this check box, the media will be prefed when it is fed out, such as during cutting, preventing the pulling of the media with undue force.

Priority for Cutting Settings

Sets whether to prioritize the cutting settings of the machine or the software.

Ink Circulation Interval

Sets the frequency of white ink circulation to prevent uneven color issues.

Sleep Time

Sets the time until sleep mode (the state in which the power-saving features operate) activates.

Stopping the Warning Beep

Sets the duration of the warning beep that sounds when, for example, an error occurs.

Date and Time

Changes the date and time printed on printing tests such as nozzle drop-out tests and print & cut position adjustment.

Initialize Settings

Click **[Execute]** next to **[Return the Settings to Their Factory Default Values]** to return all settings other than Units to their factory default values.

Click **[Execute]** next to **[Initialize the Adjustment Value Set at the First Startup]** to clear the correction and adjustment values used in the initial settings.

MEMO

[Initialize the Adjustment Value Set at the First Startup] is only enabled when the sub power is off.

System Information

You can use this window to check the machine and network information.

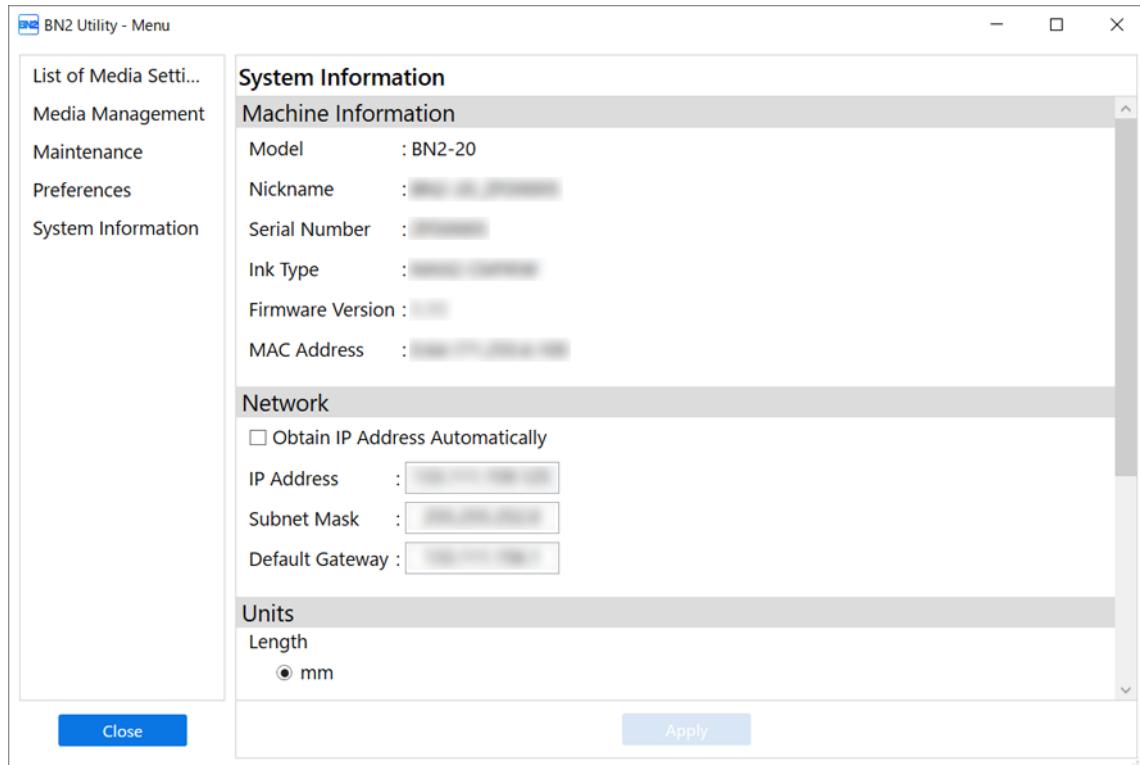

Machine information

You can check the following information:

- [Model]
- [Nickname]
- [Serial Number]
- [Ink Type]
- [Firmware Version]
- [MAC Address]

Network

You can check and edit the network settings of the connected machine.

When the [Obtain IP Address Automatically] check box is selected, the IP address of the machine is set automatically.

Units

Sets the [Length] and [Temperature].

Language

Sets the Utility display language.

Version

Displays the Utility version information.

About the Media Used

Media type

In this manual, the paper used for output is called "media." The two main types of media used in this machine are shown below.

- Roll media: Media wound onto a paper tube
- Sheet media: Media not wound onto a paper tube such as standard-size media

Various paper qualities of roll media and sheet media are selectable according to the purpose. For detailed information about each media, contact your media supplier. Media can also be purchased from our website.

RELATED LINKS

- <https://www.rolanddg.com/>

Usable Media

This machine cannot print on every kind of media. Before selecting media, be sure to perform trial printing to check whether satisfactory output quality is obtained.

Size

	Usable Media
Width *1	150 to 515 mm (5.91 to 20.27 in.)
Cuttable media thickness*1	Max. 0.22 mm (8.66 mil; depending on the media composition)
Maximum media thickness (including backing paper)*1	When only printing: 1.0 mm (39.4 mil) When performing cutting: 0.4 mm (15 mil)
Maximum roll outer diameter	150 mm (5.9 in.)
Paper tube (core) inner diameter	76.2 mm (3 in.) or 50.8 mm (2 in.)

*1 Applies to both roll and sheet media

Maximum roll weight

6 kg (13.23 lb.)

Other conditions

Media such as the following cannot be used.

- Media whose end is attached to the paper tube (core)
- Media that is severely warped or that has a strong tendency to reroll
- Media that cannot withstand the heat of the media heating system
- Media whose paper tube (core) is bent or crushed
- Media that bends under its own weight when loaded
- Media on a sagging roll
- Media that is rolled unevenly

Four Different Output Methods

The following four output methods are available for this machine.

Printing (Only)	Printing using ink. It is also called "Printing Only" to distinguish from "Printing and Cutting."
Cutting (Only)	Cutting using a blade such as for seal die cutting. It is also called "Cutting Only" to distinguish from "Printing and Cutting."
Printing and Cutting	Printing method in which printing is followed by cutting. If output data that contains both printing and cutting information is sent to the printer, the cutting operation starts after printing finishes.
Cutting with Crop Marks	Output method using "Crop Marks" to align the printing and cutting results. If you are printing on the media, removing it so it can be laminated, and then setting up the media again to cut it, use the crop marks to align the media.

You can also use sheet cutting to print on media and then separate it. The media is fed and pulled back to separate it at the desired location. You can also specify perforation.

Important Points During Use

Use the machine periodically

We recommend using the machine at least once a week. If left unused for a long period of time, the ink may settle, resulting in unstable discharge (and nozzle clogging). Any dry ink will need to be discharged.

Printing-start Location

The output-start location is always the point shown in the figure below.

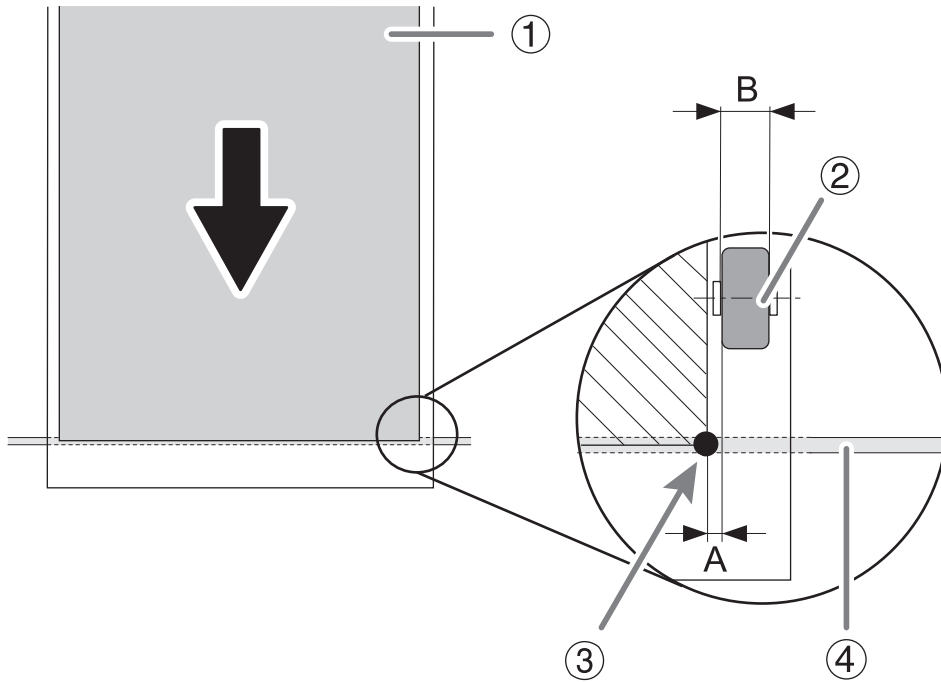

①	Printing area
②	Right pinch roller
③	Output-start location
④	Blade protector
A	1.5 mm (0.06 in.)
B	5 mm (0.2 in.)

Basic Operations

Power Supply Operations	31
Turning the Power On	31
Turning the Power Off (Sub-power Off)	34
Precautions When Operating the Power Supply	36
Sleep Mode (Power-saving Feature)	36
Setup of New Media	37
Setup of Roll Media	37
Setup of Sheet Media	53
Setup of Registered Media	63
Setup of Roll Media	63
Setup of Sheet Media	78
Checking before Output	86
LAN (Local Area Network) Settings	86
Preventing Sedimentation in Inks	86
Pausing and Canceling Output	88
Pausing and Resuming Output	88
Canceling Output	89
Separating the Media	91

Power Supply Operations

You can switch the sub power on and off with a button on the machine and an icon in the Utility window.

MEMO

This machine has a feature that automatically performs maintenance periodically. Even if the sub power is off, the automatic maintenance feature may activate, causing the machine to operate.

Turning the Power On

⚠ WARNING

Remove any loaded media or switch off the sub power when printing is not being performed.

The continued application of heat at a single location may cause the release of toxic gases from the media or pose a fire hazard.

Turning the Power On with the Button on the Machine

Procedure

1. Close the front cover.
2. Turn on the main power switch.

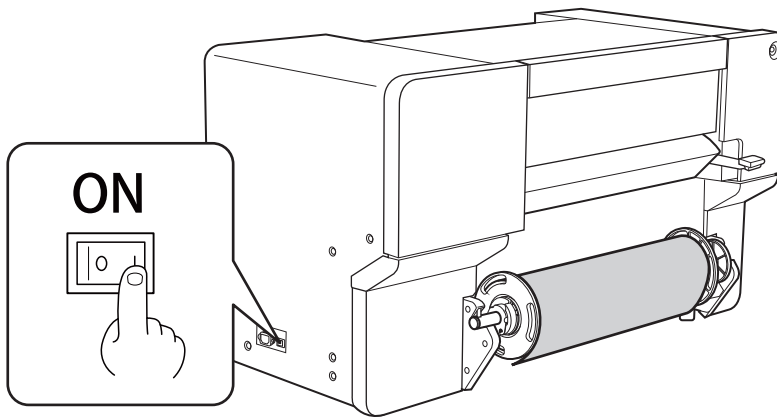

3. Press the sub power button.

The sub power is switched on. When the sub power button indicator changes from flashing to steady, startup is finished.

MEMO

After switching on the main power, wait some time before pressing the sub power button.

Firmware initialization starts when the main power is turned on, and there will be no response when pressing the sub power button until initialization is complete.

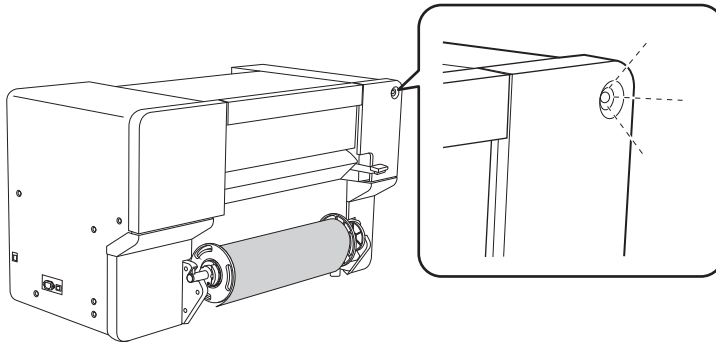

Turning the Machine On from the Utility Window

Procedure

1. Close the front cover.
2. Turn on the main power switch.

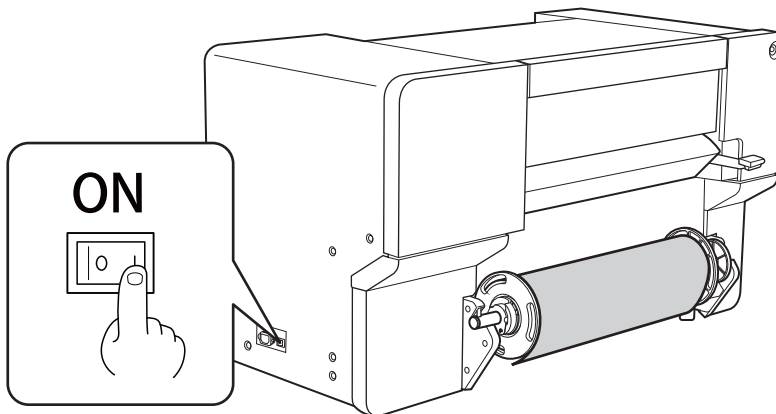



3. Start Utility.

MEMO

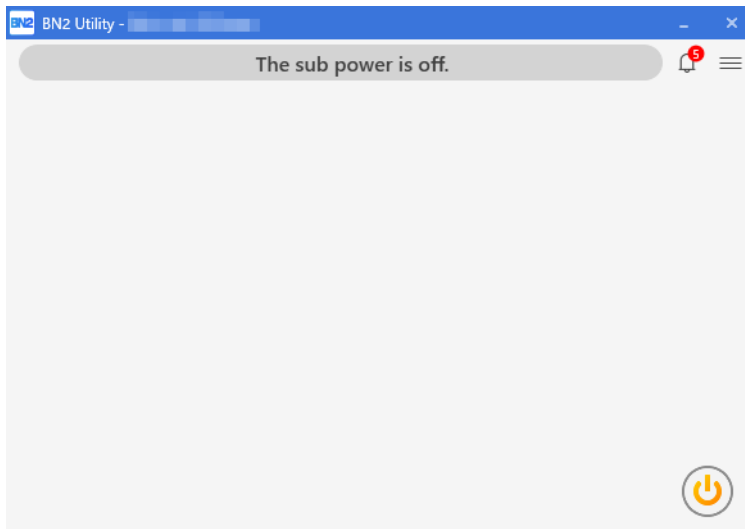
After switching on the main power, wait some time before starting Utility.
Utility cannot start until the connection between the machine and the computer finishes.



4. Click .

The sub power is switched on. When the sub power of the machine switches on, the  button in the Utility window changes to .



Turning the Power Off (Sub-power Off)

⚠ WARNING

Remove any loaded media or switch off the sub power when printing is not being performed. The continued application of heat at a single location may cause the release of toxic gases from the media or pose a fire hazard.

Turning the Machine Off by Operating It

Procedure

1. When output finishes, hold down the sub power button for 1 second or longer.
When the sub power button's indicator turns off, the machine has finished switching off.
2. Raise the loading lever and remove the media.
When not using the machine, raise the loading lever even if the sub power is on.

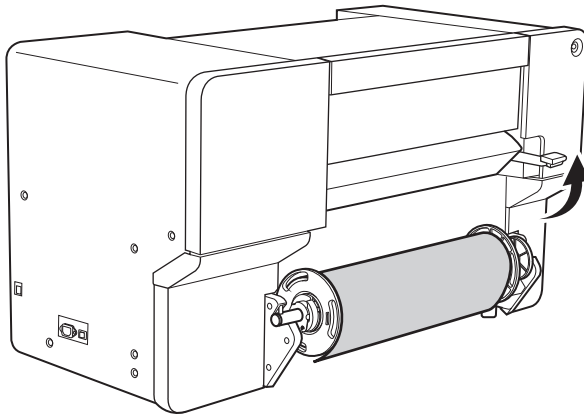



Turning the Machine Off from the Utility Window

Procedure

1. When output finishes, click  in the Utility window.

Click [OK] to switch the sub power off.

When the sub power of the machine switches off, the  button in the Utility window changes to .

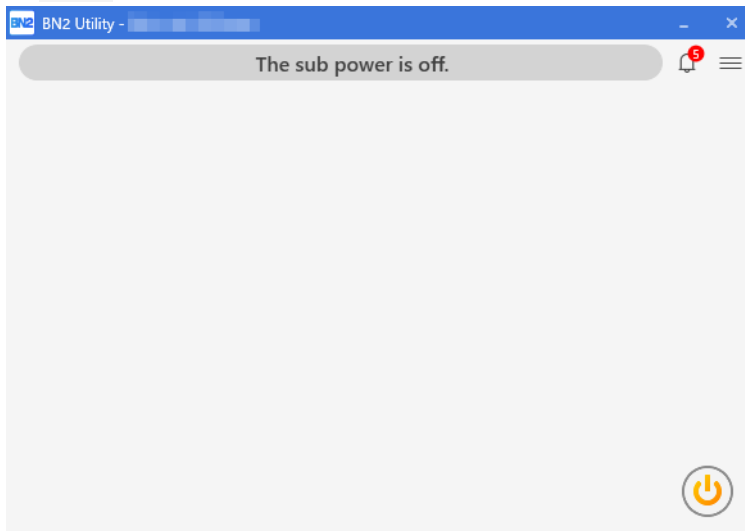

2. Raise the loading lever and remove the media.

When not using the machine, raise the loading lever even if the sub power is on.

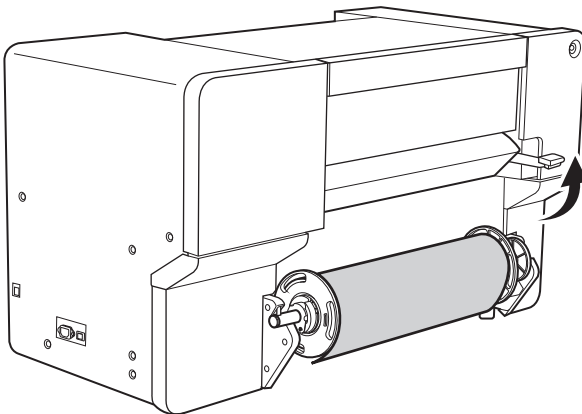

Precautions When Operating the Power Supply

IMPORTANT

Always keep the main power switched on.

Never switch off the main power. Leaving the main power enables the automatic maintenance to be carried out periodically. If the automatic maintenance is not carried out, it may result in the breakdown of this machine, such as the breakdown of the print heads.

Never switch off the main power or unplug the power cord suddenly while operation is in progress.

Switching off the main power or unplugging the power cord suddenly while operation is in progress may damage the print heads. Be sure to first hold down the sub power button to switch off the sub power.

If the main power is accidentally switched off, immediately turn the main power and sub power back on.

Sleep Mode (Power-saving Feature)

This machine is provided with a power-saving feature that switches to a low-power "sleep mode" when a fixed interval passes with no operation.

When the machine is in the sleep mode, the sub power button flashes slowly. Operating the sub power button or sending printing data from the computer when media has been set up restores the machine to the normal mode.

MEMO

- Default setting: [30 min]

RELATED LINKS

- [P. 199 Setting the Activation Interval for Sleep Mode \(Power-saving Feature\)](#)

Setup of New Media

Setup of Roll Media

Load the roll media on the printer. When the loading is finished, [Output possible.] is displayed as the status. This work is referred to as "Setup of Media."

⚠ CAUTION

Load the roll media correctly.
Otherwise the media may fall and cause injury.

1. Load the roll media.

Load the roll media onto the media flange and then load it in the machine. This procedure is not necessary when using sheet media.

MEMO

Use the following link to view a reference video for this procedure. We recommend that you view this video to understand the overall flow of work.

<https://vimeo.com/1003476467/d0c94b8c81>

The BN2-20/20A is shown in this video, but the work and operation procedures are the same for this machine.

Procedure

1. Remove the media shaft from the machine.
2. Open the lock lever (①) on the left media flange in the direction of the arrow, and remove the flange from the media shaft.

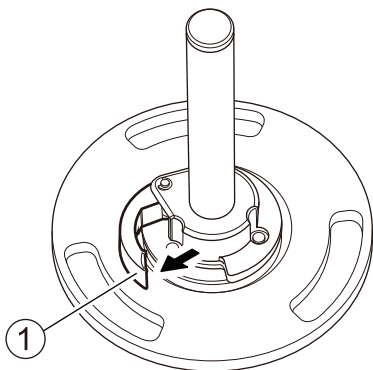

3. Check the orientation of the right media flange (①).

With the factory default settings, the right media flange is installed so that loading of roll media with a 3-inch paper tube inner diameter is possible.

To load roll media with a 2-inch paper tube inner diameter, change the orientation of the right media flange using the following procedure.

- (1) Remove the snap pin (②) and pull out the mounting pin (③).
- (2) Remove the right media flange from the media shaft (④).
- (3) Change the orientation of the right media flange and install it on the media shaft with the 3-inch side (⑤) facing the stopper (⑥).

(4) Secure the right media flange and media shaft with the mounting pin, and then attach the snap pin.

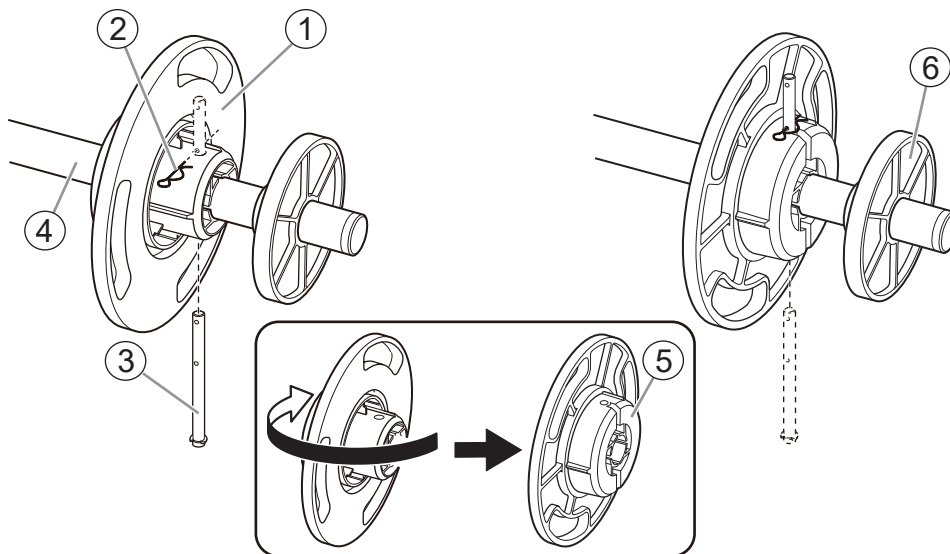

4. Load the roll media onto the media flange.

Place the media shaft flange at the bottom and load the roll media so that the media feeds in the clockwise direction when viewed from above.

MEMO

Media cannot be loaded correctly if the direction of the roll media is incorrect.
Install the roll media so there is no gap between it and the media flange.
To keep the printing result from being negatively affected, prevent contact with the media print surface as much as possible.

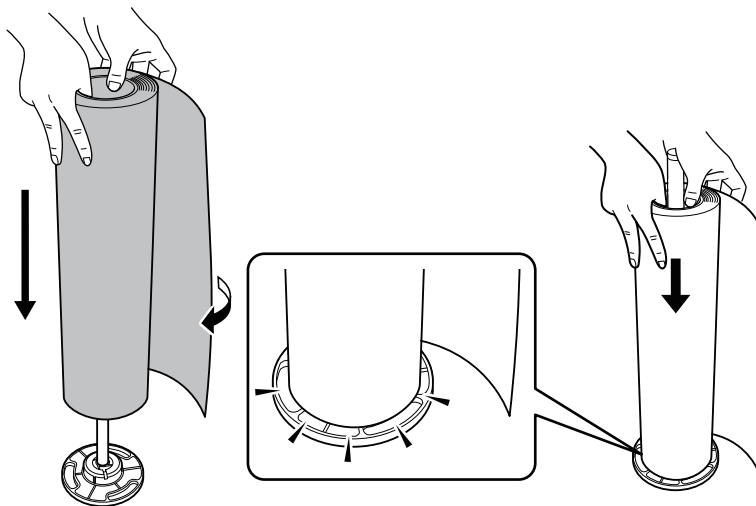

5. Install the left media flange.

Install the media flange so there is no gap between it and the roll media.

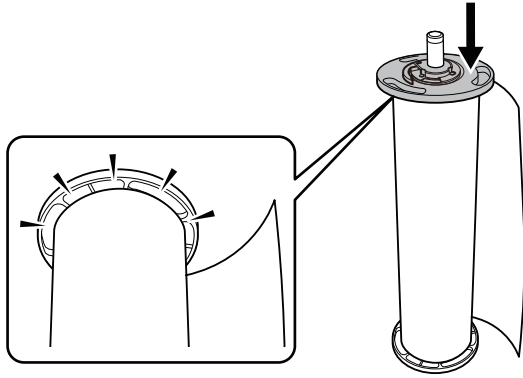

6. Secure the left media flange in place.

Close the lock lever in the direction of the arrow to secure the left media flange in place.

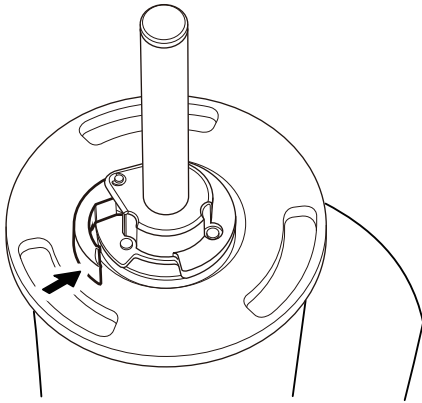

7. Load the roll media on the printer.

IMPORTANT

When loading the media, hold by the media flange to prevent contact with the media print surface.

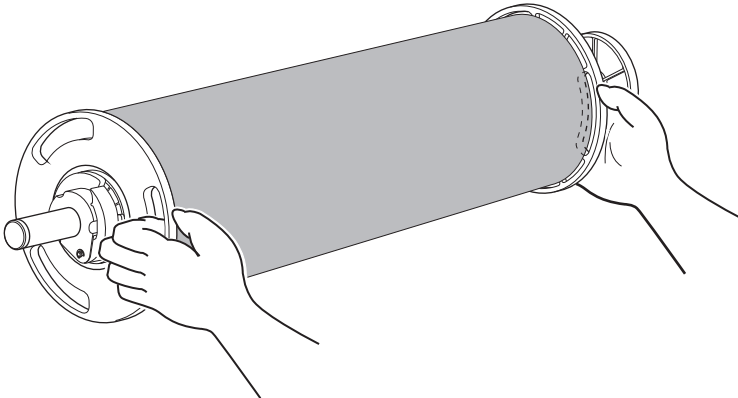

(1) Align the stopper (①) with the guide (②).

(2) Press the left and right ends of the media shaft into the shaft holder until you hear a click.

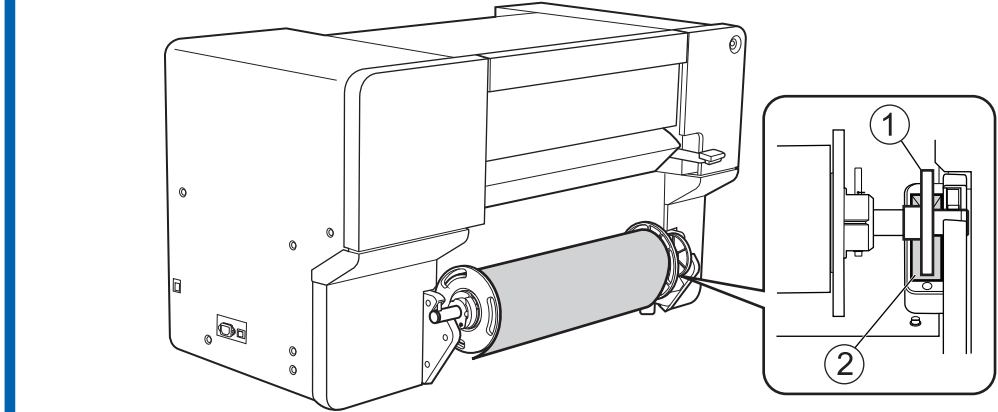

2. A: Determining the Positions of the Media

This section describes how to use the suction fan to prevent media skewing. When using transparent media, whose edges cannot be detected, and when [Enable Detection] under [Preferences]>[Media Edge Detection Method] is set to [Off], the suction fan does not activate, so media cannot be loaded with this procedure. In these cases, refer to 2. B: Determining the Positions of Media (If [Media Edge Detection Method]: Off)(P. 45). By default, [Skewing Correction Support at Setup] is set to [Enable Support].

MEMO

Use the following link to view a reference video for this procedure. We recommend that you view this video to understand the overall flow of work.

<https://vimeo.com/1003476339/5eb7f8a611>

The BN2-20/20A is shown in this video, but the work and operation procedures are the same for this machine.

Procedure

1. Open the front cover.

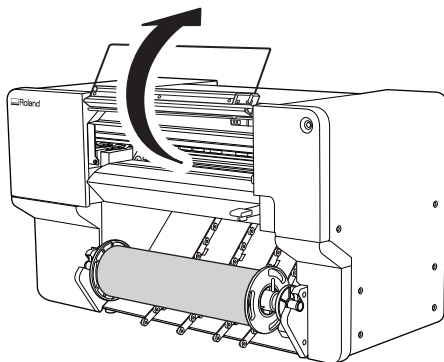

2. Move the right pinch roller (①) and the right media clamp (②) to the right end.

Press the part indicated by the arrow on the right pinch roller to move the roller and the right media clamp together.

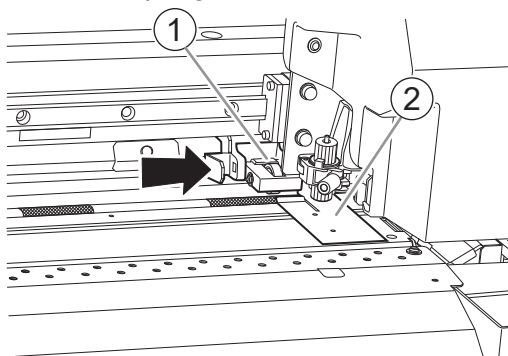

3. Move the left pinch roller (①) and the left media clamp (②) to the left end.

Press the part indicated by the arrow on the left pinch roller to move the roller and the left media clamp together.

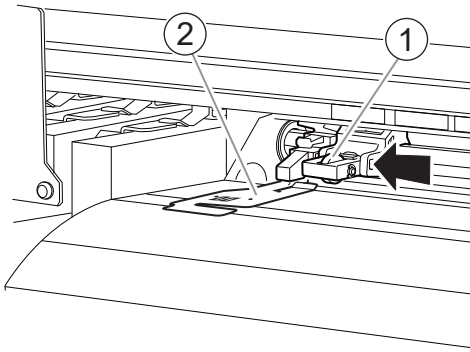

4. Use the following procedure to load the media.

- (1) Pull out the media and load it from above the plate in front with the arrow stickers.

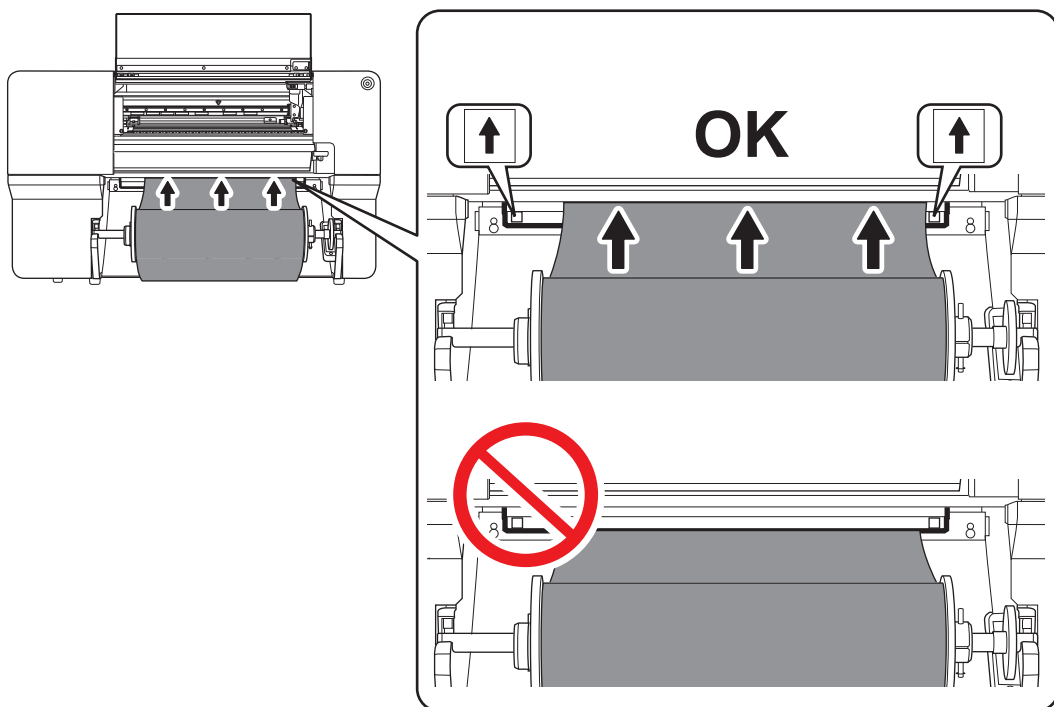

- (2) Pass the media (①) between the right grit roller (②) and right pinch roller (③).

MEMO

If the left edge of the media is left of the left pinch roller, pass the media between the left grit roller and left pinch roller as well.

- (3) Pass the media (①) under the right media clamp (②), and pull it out about 20 cm (7.87 in.) from the edge of the apron (③).

MEMO

If the left edge of the media hits the left media clamp, pass the media under the left media clamp.

MEMO

You will hear a beep. Approximately 2 seconds later, you will hear two beeps, and then the suction fan will activate. While this fan is operating, the position of the media will be maintained even if you remove your hands from it.

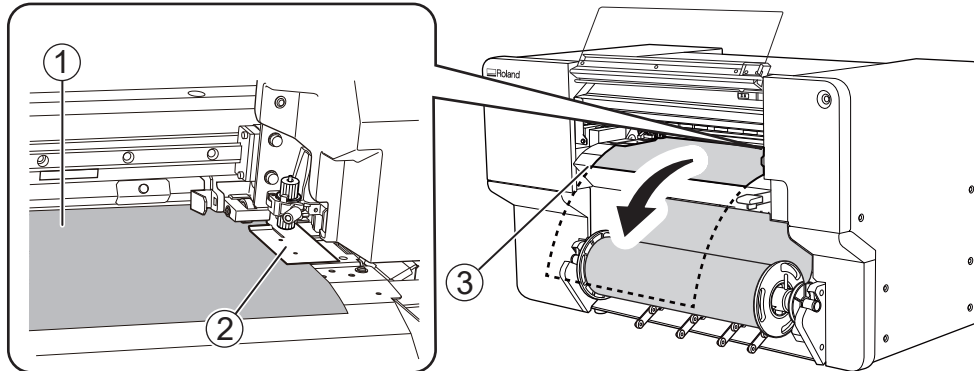

- (4) Hold the media holder flange and take up about 20 cm (7.87 in.) of media.

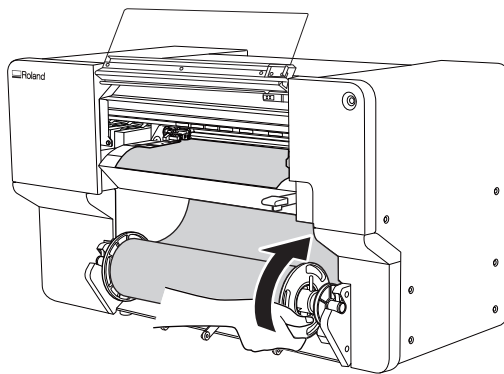
**MEMO**

When taking up the media (1), ensure that the sensor (2) remains hidden.

If you take up too much media and make the sensor visible, you will hear two short beeps and the suction fan will stop. If the media comes off or is not straight, take up the media and redo the procedure from step 4.

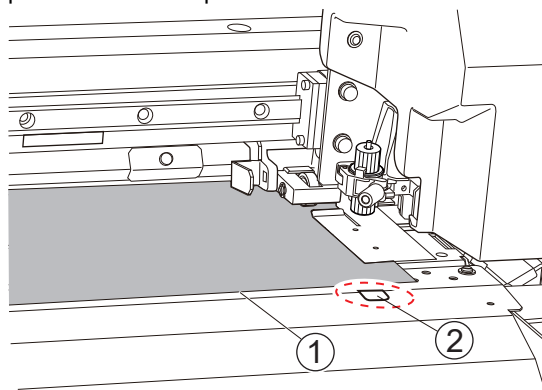

5. Place the left media clamp and the left pinch roller.

Place the left pinch roller (2) within the grit pattern (1).

Ensure that margin A from the left edge of the media to the left edge of the left pinch roller is at least 10 mm (0.39 in.).

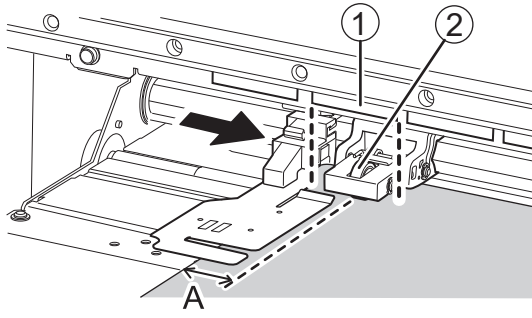

6. Lower the loading lever.

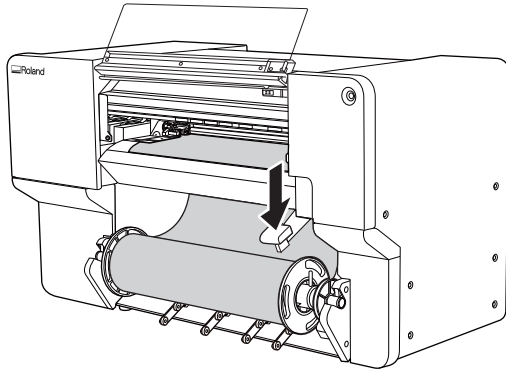

7. Line up the edges of the media with the centers of the holes of the left media clamp.

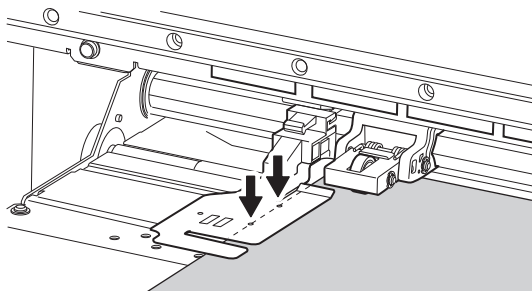

8. Close the front cover.

2. B: Determining the Positions of Media (If [Media Edge Detection Method]: Off)

This section describes how to determine the positions of the media without using the suction fan. Use this method in the following situations.

- When you are using transparent media whose edges cannot be detected.
- When [Enable Detection] under [Preferences]>[Media Edge Detection Method] is set to off.

Procedure

1. Open the front cover.

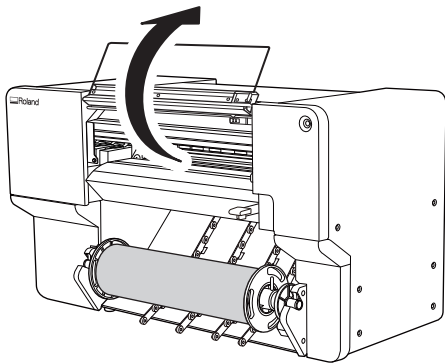

2. Move the right pinch roller (①) and the right media clamp (②) to the right end.

Press the part indicated by the arrow on the right pinch roller to move the roller and the right media clamp together.

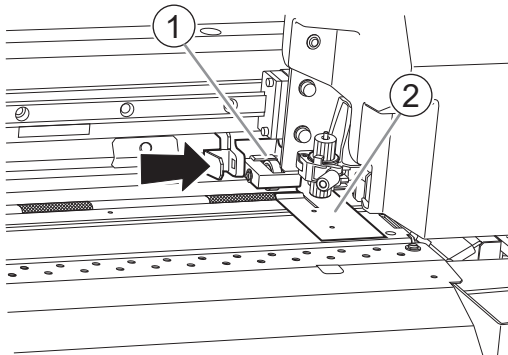

3. Move the left pinch roller (①) and the left media clamp (②) to the left end.

Press the part indicated by the arrow on the left pinch roller to move the roller and the left media clamp together.

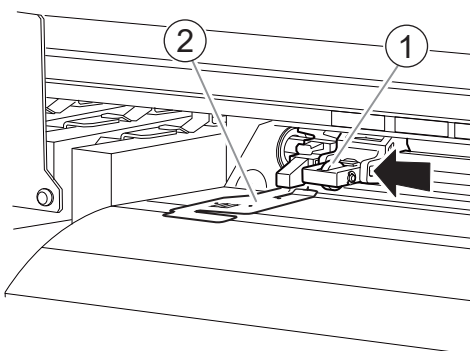

4. Use the following procedure to load the media.

- (1) Pull out the media and load it from above the plate in front with the arrow stickers.

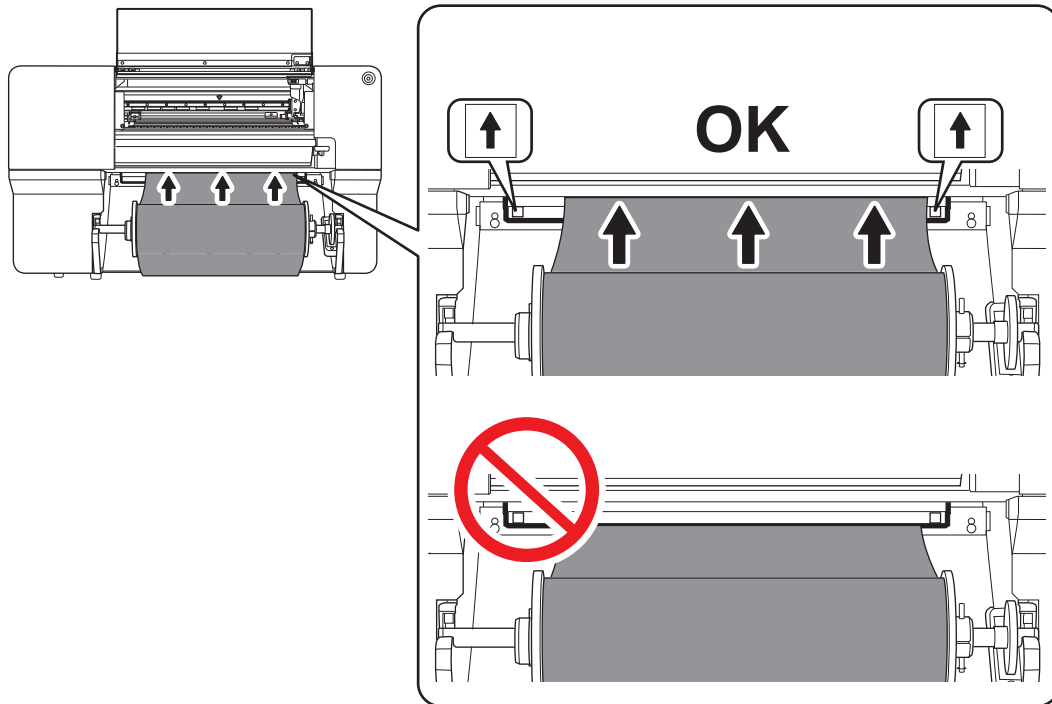

- (2) Pass the media (①) between the right grit roller (②) and right pinch roller (③).

MEMO

If the left edge of the media is left of the left pinch roller, pass the media between the left grit roller and left pinch roller as well.

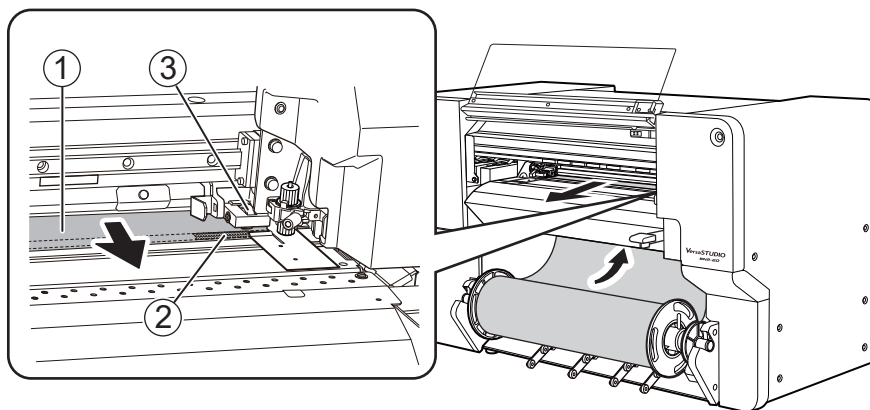

- (3) Pass the media (①) under the right media clamp (②), and pull it out about 20 cm (7.87 in.) from the edge of the apron (③).

MEMO

If the left edge of the media hits the left media clamp, pass the media under the left media clamp.

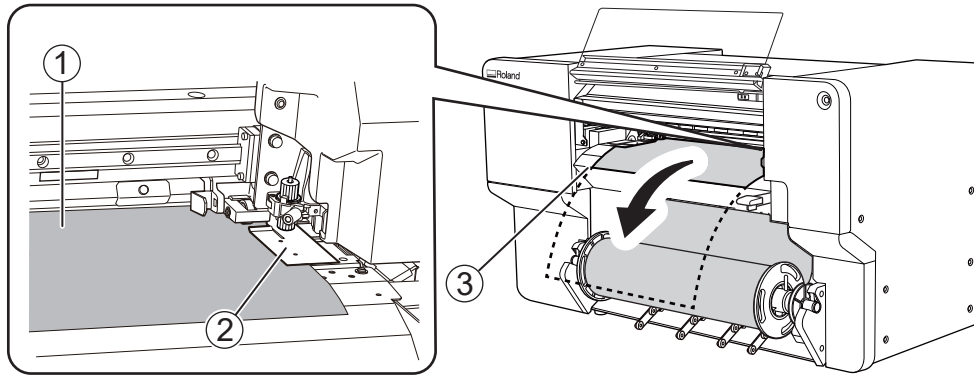

- (4) While lightly holding down the media, hold a media holder flange and take up approximately 20 cm (7.87 in.) of media.

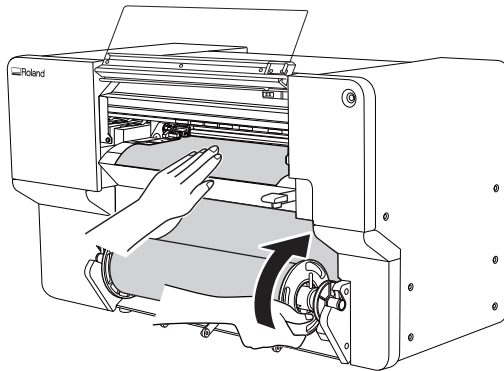

5. While lightly holding down the media by hand, position the left media clamp and the left pinch roller.

Place the left pinch roller (2) within the grit pattern (1).

Ensure that margin A from the left edge of the media to the left edge of the left pinch roller is at least 10 mm (0.39 in.).

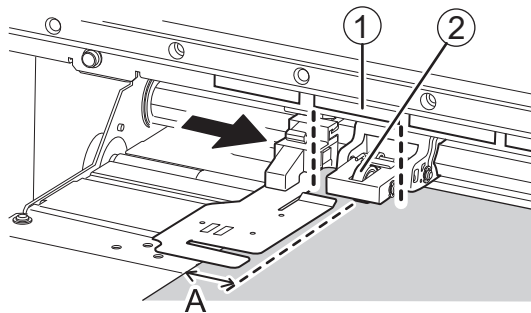

6. Lower the loading lever.

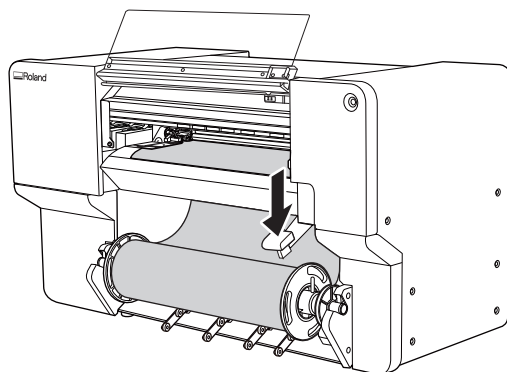

7. Line up the edges of the media with the centers of the holes of the left media clamp.

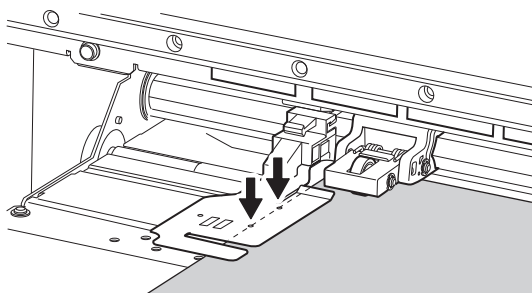

8. Close the front cover.

3. Register the media.

Procedure

1. Click  [Setup].

2. Click .

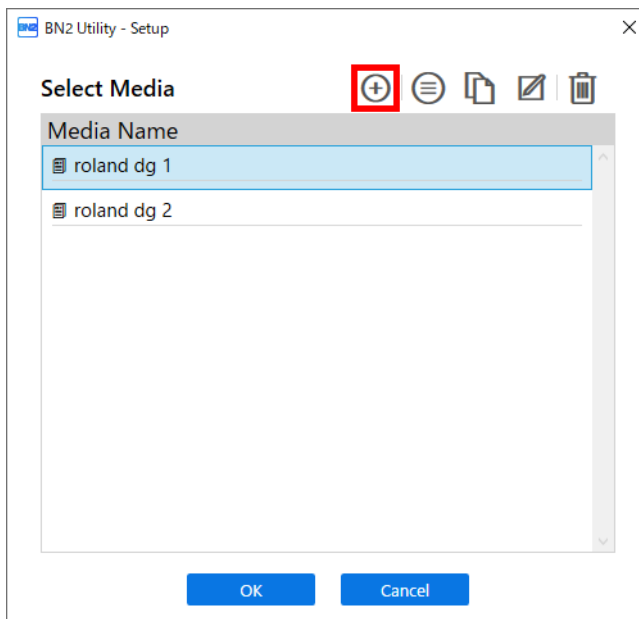

3. Enter a new media name and click [OK].

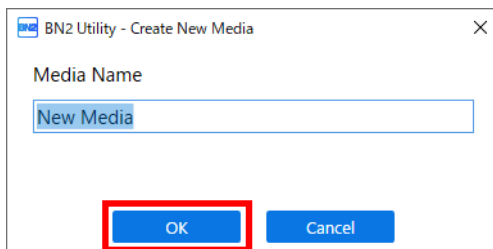

4. When the [Load the media, and then make sure that the loading lever is lowered. Start setup.] window appears, click [OK].

The print-head carriage moves, performing the setup operation.

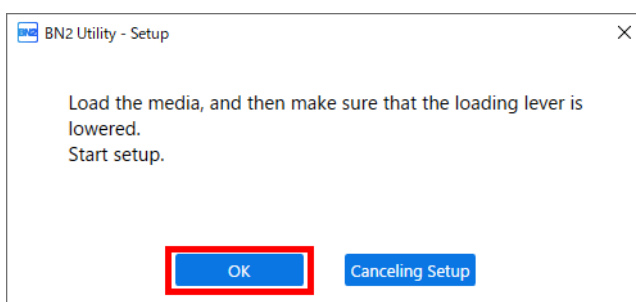

MEMO

Setup is not possible if a cover is open or the loading lever is raised. Close the covers and lower the loading lever.

If an error appears, check the error message, clear the error, and then click **[OK]**.

[P. 283 Error Messages](#)

MEMO

After clearing the error, if a setup error occurs, click **[OK]**.

4. Configure settings to match the media.

To ensure the optimal output according to the media size and type, set the minimal amount of items. All items set here can be set individually as well.

Procedure

1. On the [Select Media Output Type] window, select the output type, and then click [OK].

- [Print Only/Print & Cut]

Proceed to step 2.

- [Cut Only]

Switch to [Multi Sensor Adjustment].

Click [OK] to perform adjustments automatically. When adjustment is finished and a message appears, click [OK] to switch to the home screen. This completes the setup.

If the adjustment failed, respond to the failure according to the information in [Correcting the Reading Sensor \(Multi Sensor Adjustment\)](#).

2. In the [Nozzle Drop-out Test] window, click [Output].

Printing of the test pattern starts.

3. Check the result of the printing test.

If the result of the printing test is satisfactory, click [OK].

MEMO

If dot drop-out or dot displacement occurs, click [Normal Cleaning]>[Execute] under [Head Cleaning].

For the action to perform when dot drop-out or dot displacement is not corrected after performing [Normal Cleaning] multiple times, refer to [Medium Cleaning](#).

4. On the [Select Media Adjustment Method] window, select the adjustment method.

Here, the media feed correction for reducing horizontal bands and the correction of the landing position of the ink will be adjusted.

The printing area must be 300 mm (11.82 in.) or more with simple correction (automatic) and 340 mm (13.39 in.) or more with detailed correction (manual).

MEMO

[Simple Correction (Auto)] is the recommended adjustment. You can determine the correction values with [Detailed Correction (Manual)].

[Simple Correction (Auto)] may not be possible depending on the media you are using. For example, this method cannot be used with transparent media.

If the message [Adjustment failed.] appears, perform manual correction.

- Follow the procedure below to make automatic adjustments.

- a. Select [Simple Correction (Auto)], and then click [OK].

- b. When the automatic correction items appear, click [OK].

Printing of the test pattern starts, and correction is performed automatically.

On successful completion of automatic adjustment, the message [New media setup is complete.] appears. Click [OK] to finish the corrections.

For more information, refer to [Automatically Making Required Adjustments](#).

- Follow the procedure below to make manual adjustments.

- a. Select [**Detailed Correction (Manual)**], and then click [**OK**].
- b. In the [**Multi Sensor Adjustment**] window, click [**OK**].

On successful completion of adjustment, the [**Detailed Feed Correction (Manual)**] window appears.

If the adjustment failed, respond to the failure according to the information in [Correcting the Reading Sensor \(Multi Sensor Adjustment\)](#).
- c. In the [**Detailed Feed Correction (Manual)**] window, click [**Output**].

Set the correction values from the printing result of the test pattern. For more information, refer to [Manual Adjustment: Reducing Horizontal Bands \(Feed Correction\)](#).
- d. When you have set the correction values, click [**OK**].
- e. In the [**Detailed Media Gap Adjustment (Manual)**] window, click [**Output**].

Set the correction values from the printing result of the test pattern. For more information, refer to [Manual Adjustment: Adjusting the Misalignment of the Ink Landing Position \(Media Gap Adjustment\)](#).
- f. When you have set the correction values, click [**OK**].
- g. When the [**New media setup is complete.**] window appears, click [**OK**].

This completes the corrections. The home screen appears.

This completes the setup of the media.

Setup of Sheet Media

Load the sheet media on the printer. When the loading is finished, [Output possible.] is displayed as the status. This work is referred to as "Setup of Media."

1. Determining the Positions of the Media

When loading sheet media in the machine, use the right edge of the media as a reference. This is because the range of movement of the right pinch roller is fixed.

Place the media in a position where the following conditions are met and where media waste will be minimized.

- Position of right edge of media

Within the right pinch roller movable range and where about 10 mm (0.39 in.) between the right roller edge of the right pinch roller and the right edge of the media can be secured.

- Position of left edge of media

Where about 10 mm (0.39 in.) between the left edge of the roller and the left edge of the media can be secured when placing the left pinch roller within the range of the grit pattern.

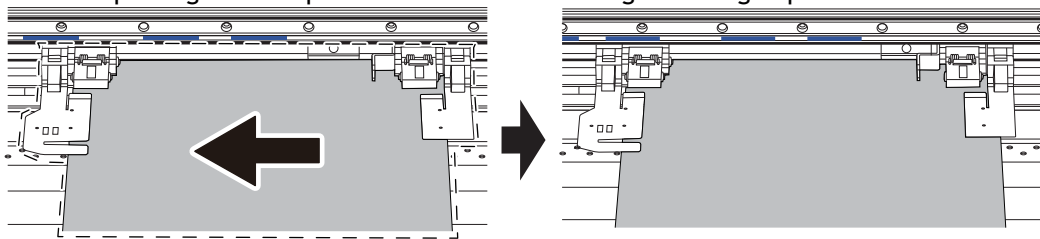

MEMO

Use the following link to view a reference video for this procedure. We recommend that you view this video to understand the overall flow of work.

<https://vimeo.com/1003475093/b41e56efdf>

The BN2-20/20A is shown in this video, but the work and operation procedures are the same for this machine.

Procedure

1. Open the front cover.

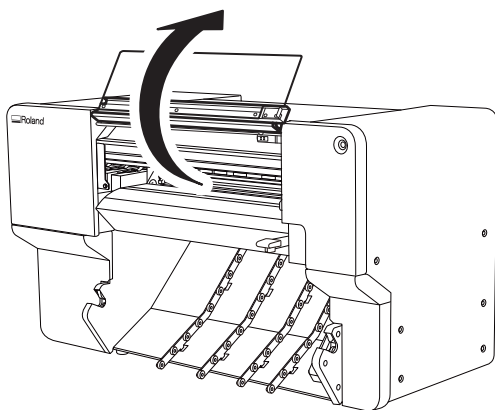

2. Move the right pinch roller (①) and the right media clamp (②) to the right end.

Press the part indicated by the arrow on the right pinch roller to move the roller and the right media clamp together.

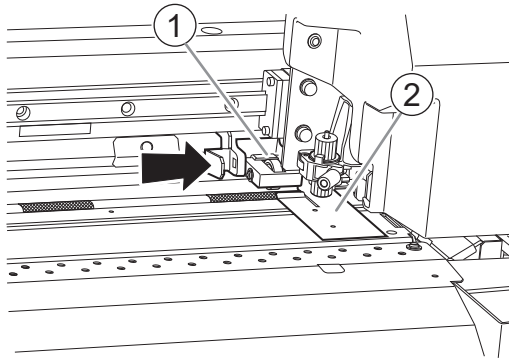

3. Move the left pinch roller (①) and the left media clamp (②) to a position farther left than the media width.

Press the part indicated by the arrow on the left pinch roller to move the roller and the left media clamp together.

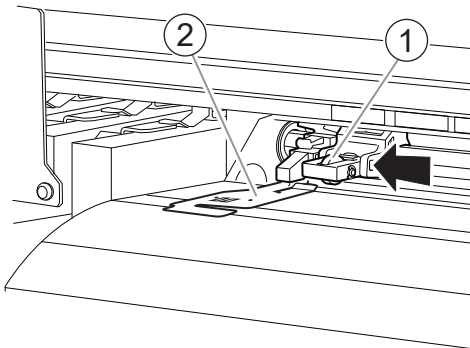

4. Use the following procedure to load the media.

- (1) Pass the media (①) under the right media clamp (②).

MEMO

If the left edge of the media hits the left media clamp, pass the media under the left media clamp.

MEMO

Lifting the tip of the media clamp to pass the media through may cause the blade to come into contact with the media. Be careful not to allow contact with the blade.

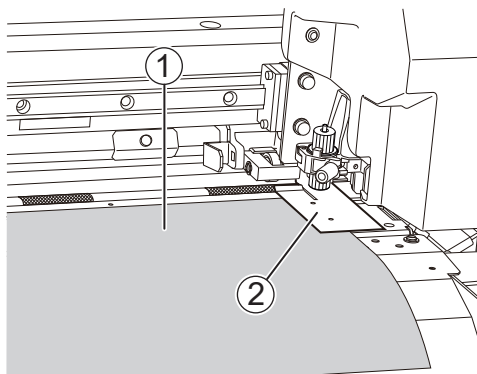

- (2) Pass the media (①) between the right grit roller (②) and the pinch roller (③) and feed the media to the back.

Feed the media and line up the edge of the media with the edge of the apron (④).

MEMO

If the left edge of the media is left of the left pinch roller, pass the media between the left grit roller and left pinch roller as well.

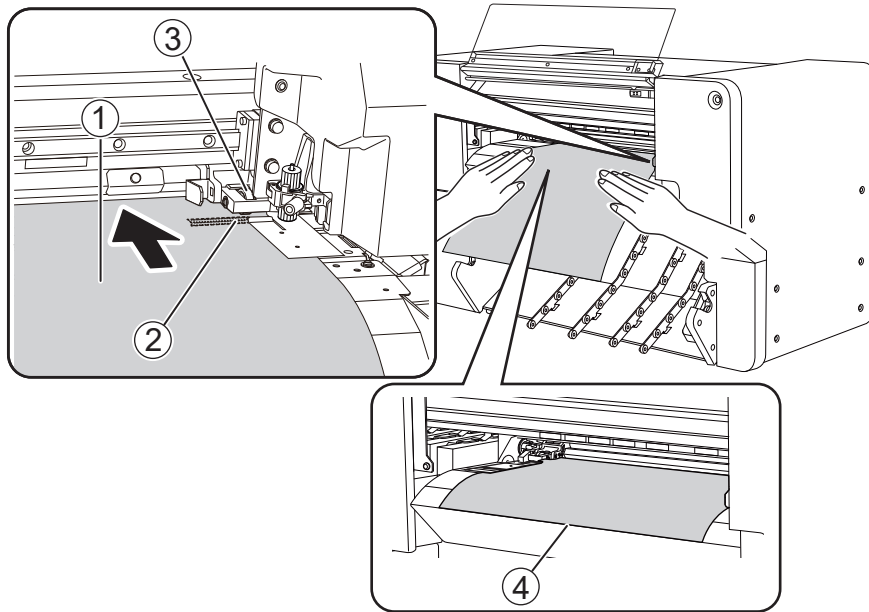

5. Straighten the media.

OK

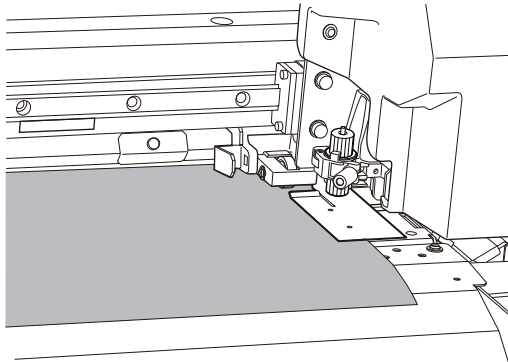

Not OK

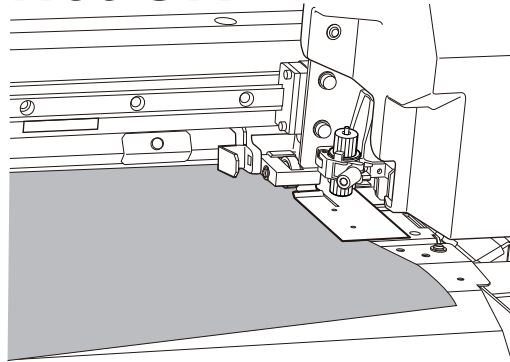

6. Press lightly on the media, and place the left media clamp and left pinch roller on the media.

(1) Position the left pinch roller ② within the range of the grit pattern ①.

Ensure that margin A from the left edge of the media to the left edge of the left pinch roller is at least 10 mm (0.39 in.).

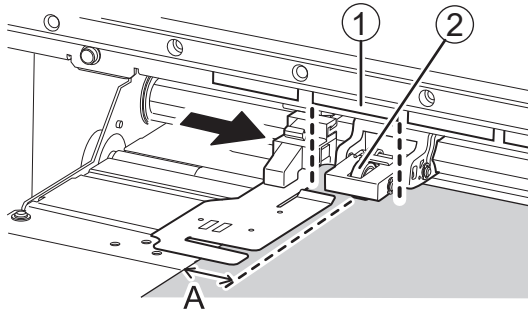

MEMO

If at least 10 mm (0.39 in.) cannot be ensured for margin A from the left edge of the media to the left edge of the left pinch roller, move the right pinch roller and the media to the left to provide the margin.

The range of motion of the right pinch roller is fixed. Place the right pinch roller within the movable range in a position that ensures margin A from the right edge of the media to the right edge of the right pinch roller is about 10 mm (0.39 in.).

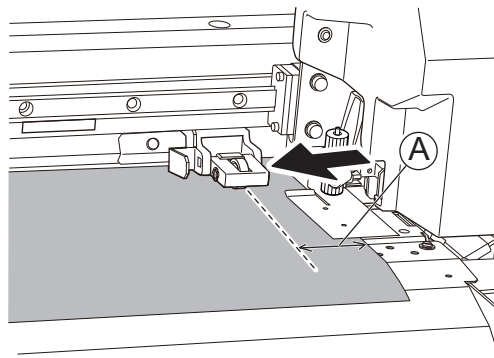

- (2) Adjust the right media clamp position as necessary.

Click  > [Preferences]>[Media Clamp Position]>[Execute] to move the print-head carriage to the left side, allowing you to adjust the right media clamp position.

Line up the edge of the media with the centers of the holes of the right media clamp.

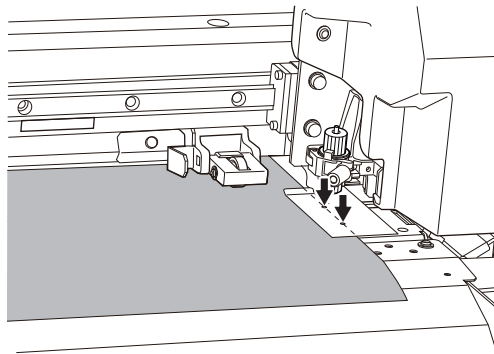

7. Lower the loading lever.

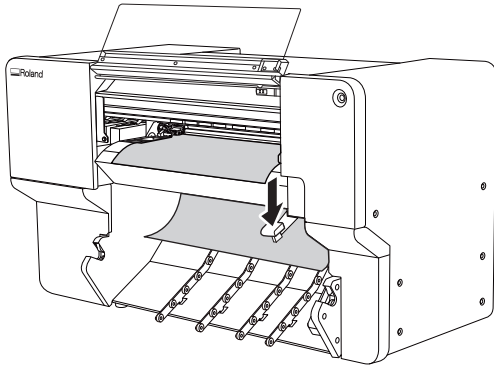

8. Line up the edges of the media with the centers of the holes of the left media clamp.

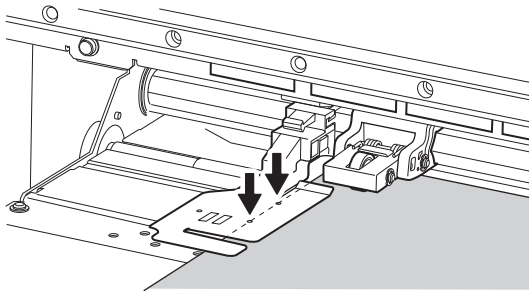

9. Feed the media in the feed direction, checking that the media stays aligned with the pinch rollers.

- (1) On the home screen, click .

The [Move] window appears.

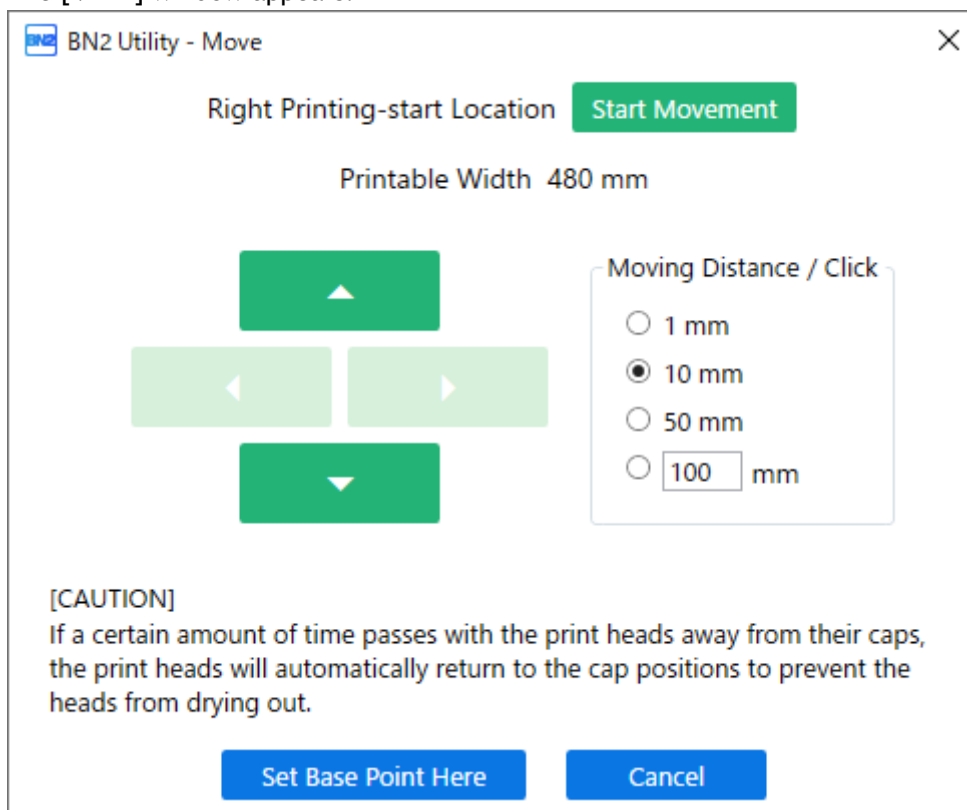

- (2) Select an option under [Moving Distance / Click], and then click .

Feed approximately 2/3 of the length of the media and check that the media stays aligned.
If the media comes off or is not straight, redo the procedure from step 4.

(3) Click  to return to the position before feeding.

If the media comes off or is not straight, redo the procedure from step 4.

10. Click [Cancel].

The [Move] window closes.

11. Close the front cover.

2. Register the media.

Procedure

1. Click  [Setup].

2. Click .

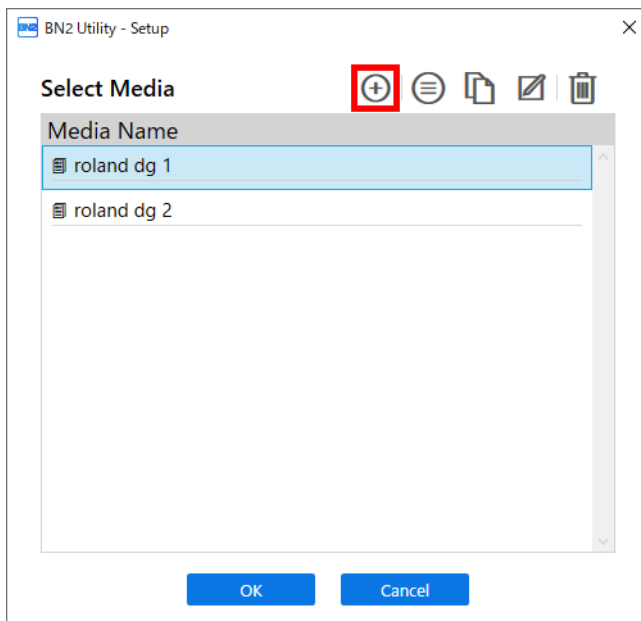

3. Enter a new media name and click [OK].

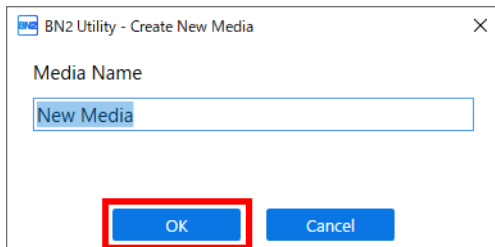

4. When the [Load the media, and then make sure that the loading lever is lowered. Start setup.] window appears, click [OK].

The print-head carriage moves, performing the setup operation.

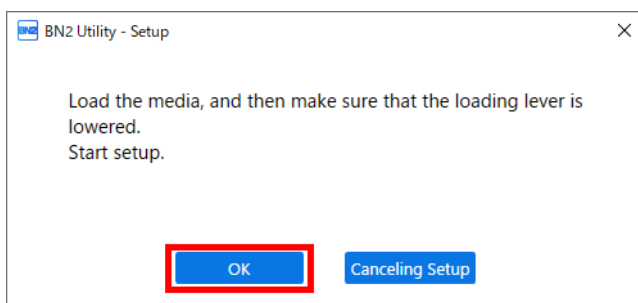

MEMO

Setup is not possible if a cover is open or the loading lever is raised. Close the covers and lower the loading lever.

If an error appears, check the error message, clear the error, and then click **[OK]**.

[P. 283 Error Messages](#)

MEMO

After clearing the error, if a setup error occurs, click **[OK]**.

3. Configure settings to match the media.

To ensure the optimal output according to the media size and type, set the minimal amount of items. All items set here can be set individually as well.

Procedure

1. On the [Select Media Output Type] window, select the output type, and then click [OK].
 - [Print Only/Print & Cut]
Proceed to step 2.
 - [Cut Only]
Switch to [Multi Sensor Adjustment].
Click [OK] to perform adjustments automatically. When adjustment is finished and a message appears, click [OK] to switch to the home screen. This completes the setup.
If the adjustment failed, respond to the failure according to the information in [Correcting the Reading Sensor \(Multi Sensor Adjustment\)](#).
2. In the [Nozzle Drop-out Test] window, click [Output].
Printing of the test pattern starts.
3. Check the result of the printing test.
If the result of the printing test is satisfactory, click [OK].

MEMO

If dot drop-out or dot displacement occurs, click [Normal Cleaning]>[Execute] under [Head Cleaning].
For the action to perform when dot drop-out or dot displacement is not corrected after performing [Normal Cleaning] multiple times, refer to [Medium Cleaning](#).

4. On the [Select Media Adjustment Method] window, select the adjustment method.
Here, the media feed correction for reducing horizontal bands and the correction of the landing position of the ink will be adjusted.
The printing area must be 300 mm (11.82 in.) or more with [Simple Correction (Auto)] and 340 mm (13.39 in.) or more with [Detailed Correction (Manual)].

MEMO

[Simple Correction (Auto)] is the recommended adjustment. You can determine the correction values with [Detailed Correction (Manual)].

[Simple Correction (Auto)] may not be possible depending on the media you are using. For example, this method cannot be used with transparent media.

If the message [Adjustment failed.] appears, perform manual correction.

- Follow the procedure below to make automatic adjustments.
 - a. Select [Simple Correction (Auto)], and then click [OK].
 - b. When the automatic correction items appear, click [OK].
Printing of the test pattern starts, and correction is performed automatically.
On successful completion of automatic adjustment, the message [New media setup is complete.] appears. Click [OK] to finish the corrections.
For more information, refer to [Automatically Making Required Adjustments](#).
- Follow the procedure below to make manual adjustments.

- a. Select [**Detailed Correction (Manual)**], and then click [**OK**].
- b. In the [**Multi Sensor Adjustment**] window, click [**OK**].

On successful completion of adjustment, the [**Detailed Feed Correction (Manual)**] window appears.

If the adjustment failed, respond to the failure according to the information in [Correcting the Reading Sensor \(Multi Sensor Adjustment\)](#).
- c. In the [**Detailed Feed Correction (Manual)**] window, click [**Output**].

Set the correction values from the printing result of the test pattern. For more information, refer to [Manual Adjustment: Reducing Horizontal Bands \(Feed Correction\)](#).
- d. When you have set the correction values, click [**OK**].
- e. In the [**Detailed Media Gap Adjustment (Manual)**] window, click [**Output**].

Set the correction values from the printing result of the test pattern. For more information, refer to [Manual Adjustment: Adjusting the Misalignment of the Ink Landing Position \(Media Gap Adjustment\)](#).
- f. When you have set the correction values, click [**OK**].
- g. When the [**New media setup is complete.**] window appears, click [**OK**].

This completes the corrections. The home screen appears.

This completes the setup of the media.

Setup of Registered Media

Setup of Roll Media

Load the roll media on the printer. When the loading is finished, [Output possible.] is displayed as the status. This work is referred to as "Setup of Media."

⚠ CAUTION

Load the roll media correctly.

Otherwise the media may fall and cause injury.

1. Load the roll media.

Load the roll media onto the media flange and then load it in the machine. This procedure is not necessary when using sheet media.

MEMO

Use the following link to view a reference video for this procedure. We recommend that you view this video to understand the overall flow of work.

<https://vimeo.com/1003476467/d0c94b8c81>

The BN2-20/20A is shown in this video, but the work and operation procedures are the same for this machine.

Procedure

1. Remove the media shaft from the machine.
2. Open the lock lever (①) on the left media flange in the direction of the arrow, and remove the flange from the media shaft.

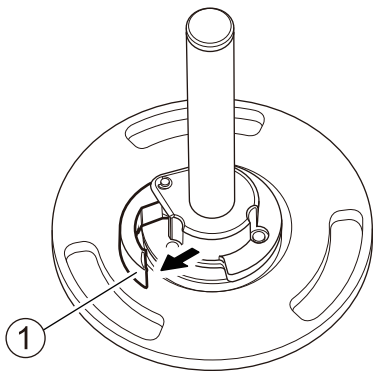

3. Check the orientation of the right media flange (①).

With the factory default settings, the right media flange is installed so that loading of roll media with a 3-inch paper tube inner diameter is possible.

To load roll media with a 2-inch paper tube inner diameter, change the orientation of the right media flange using the following procedure.

- (1) Remove the snap pin (②) and pull out the mounting pin (③).
- (2) Remove the right media flange from the media shaft (④).
- (3) Change the orientation of the right media flange and install it on the media shaft with the 3-inch side (⑤) facing the stopper (⑥).

(4) Secure the right media flange and media shaft with the mounting pin, and then attach the snap pin.

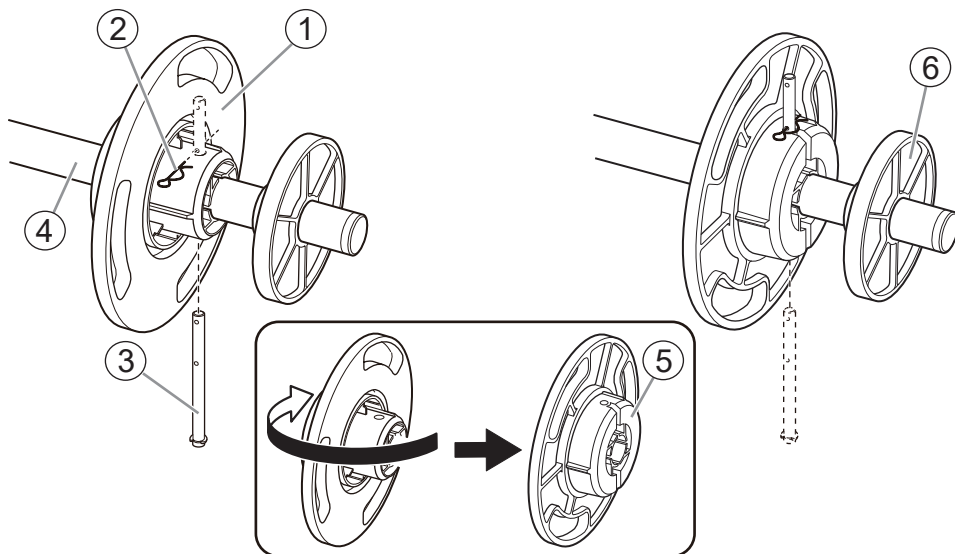

4. Load the roll media onto the media flange.

Place the media shaft flange at the bottom and load the roll media so that the media feeds in the clockwise direction when viewed from above.

MEMO

Media cannot be loaded correctly if the direction of the roll media is incorrect.

Install the roll media so there is no gap between it and the media flange.

To keep the printing result from being negatively affected, prevent contact with the media print surface as much as possible.

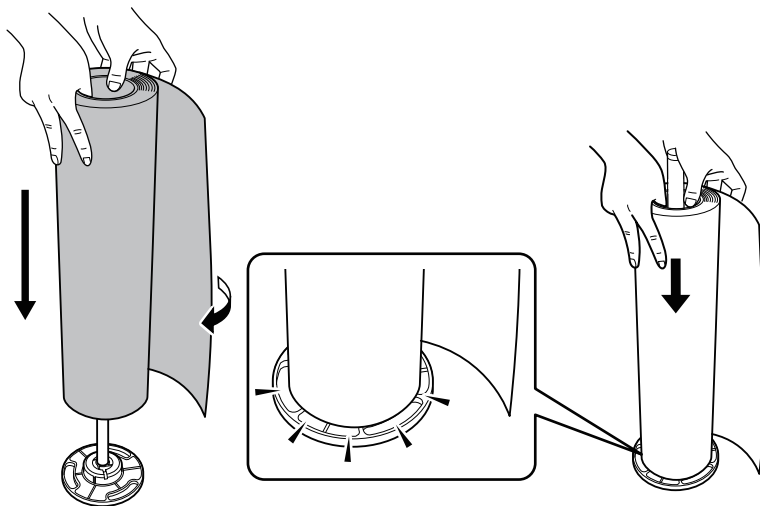

5. Install the left media flange.

Install the media flange so there is no gap between it and the roll media.

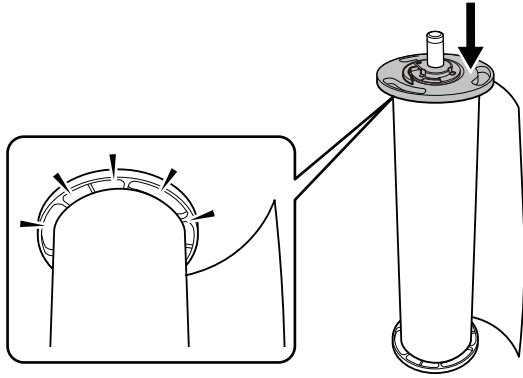

6. Secure the left media flange in place.

Close the lock lever in the direction of the arrow to secure the left media flange in place.

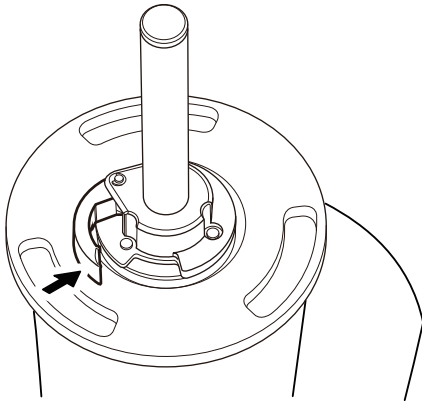

7. Load the roll media on the printer.

IMPORTANT

When loading the media, hold by the media flange to prevent contact with the media print surface.

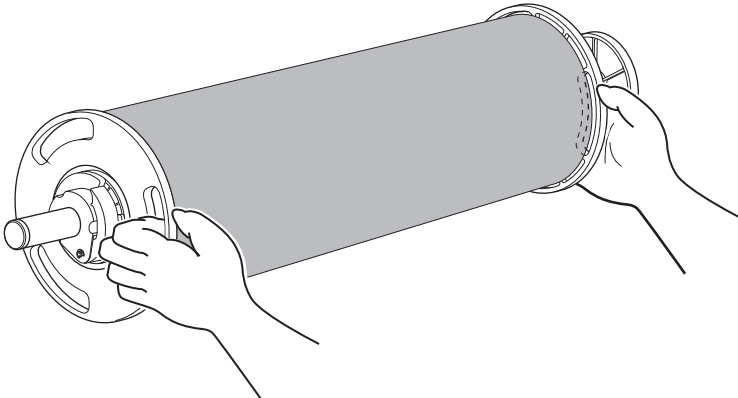

(1) Align the stopper (①) with the guide (②).

(2) Press the left and right ends of the media shaft into the shaft holder until you hear a click.

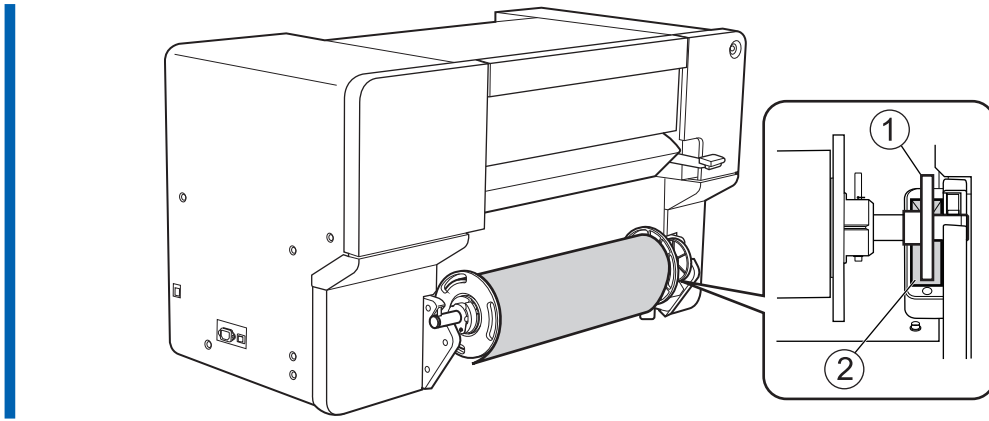

2. A: Determining the Positions of the Media

This section describes how to use the suction fan to prevent media skewing. When using transparent media, whose edges cannot be detected, and when [Enable Detection] under [Preferences]>[Media Edge Detection Method] is set to [Off], the suction fan does not activate, so media cannot be loaded with this procedure. In these cases, refer to 2. B: Determining the Positions of Media (If [Media Edge Detection Method]: Off)(P. 72). By default, [Skewing Correction Support at Setup] is set to [Enable Support].

MEMO

Use the following link to view a reference video for this procedure. We recommend that you view this video to understand the overall flow of work.

<https://vimeo.com/1003476339/5eb7f8a611>

The BN2-20/20A is shown in this video, but the work and operation procedures are the same for this machine.

Procedure

1. Open the front cover.

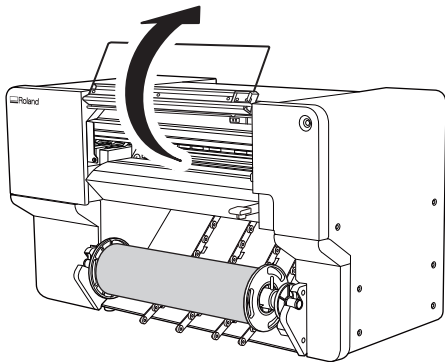

2. Move the right pinch roller (①) and the right media clamp (②) to the right end.

Press the part indicated by the arrow on the right pinch roller to move the roller and the right media clamp together.

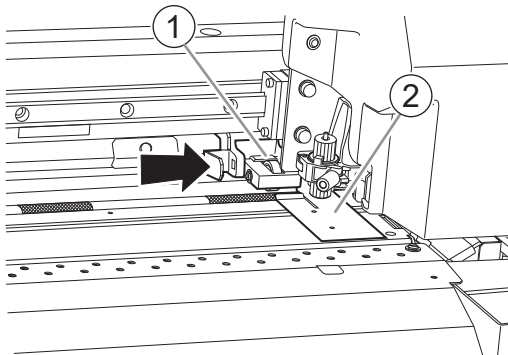

3. Move the left pinch roller (①) and the left media clamp (②) to the left end.

Press the part indicated by the arrow on the left pinch roller to move the roller and the left media clamp together.

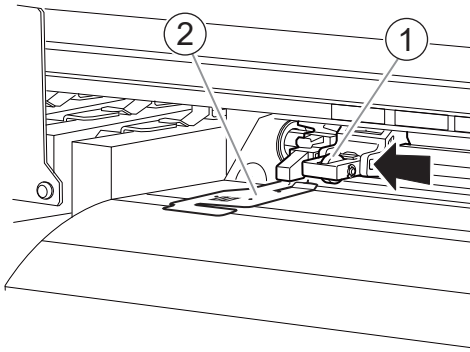

4. Use the following procedure to load the media.

- (1) Pull out the media and load it from above the plate in front with the arrow stickers.

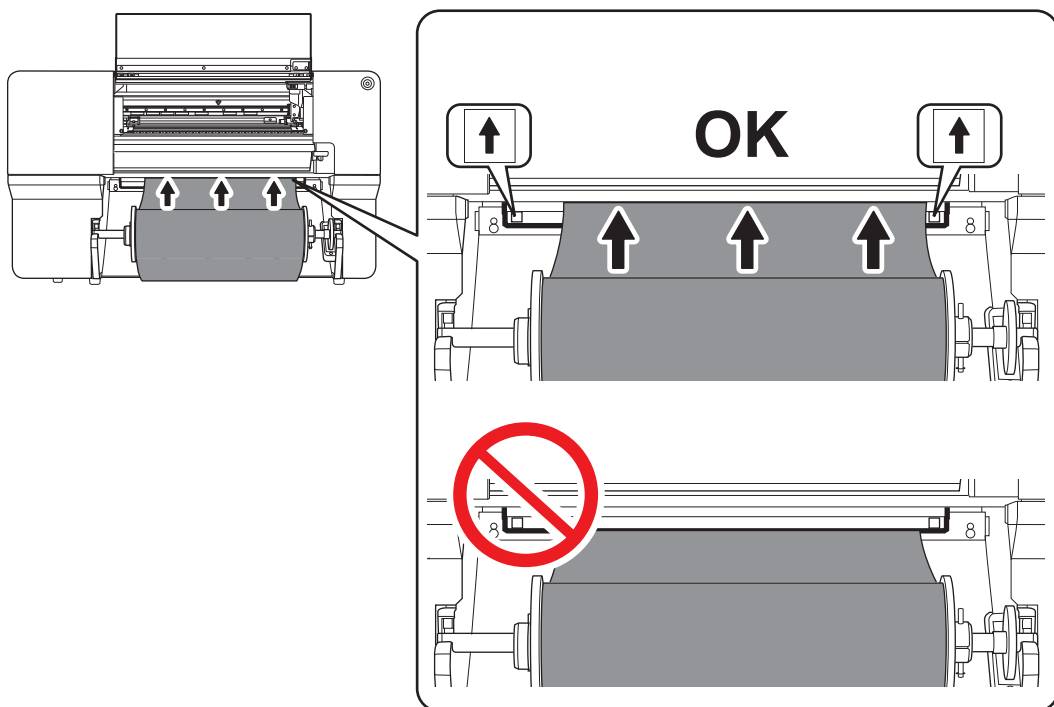

- (2) Pass the media (①) between the right grit roller (②) and right pinch roller (③).

MEMO

If the left edge of the media is left of the left pinch roller, pass the media between the left grit roller and left pinch roller as well.

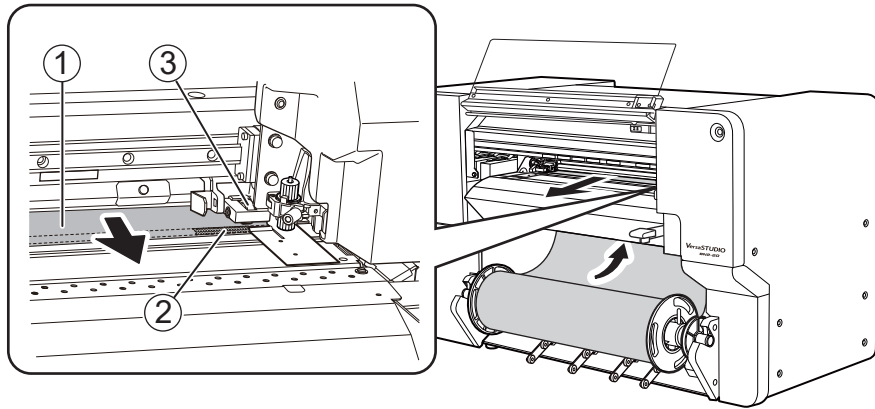

- (3) Pass the media (①) under the right media clamp (②), and pull it out about 20 cm (7.87 in.) from the edge of the apron (③).

MEMO

If the left edge of the media hits the left media clamp, pass the media under the left media clamp.

MEMO

You will hear a beep. Approximately 2 seconds later, you will hear two beeps, and then the suction fan will activate. While this fan is operating, the position of the media will be maintained even if you remove your hands from it.

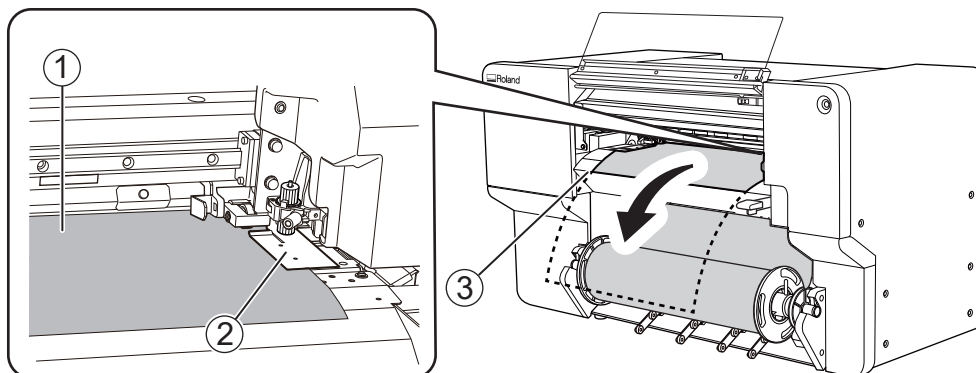

- (4) Hold the media holder flange and take up about 20 cm (7.87 in.) of media.

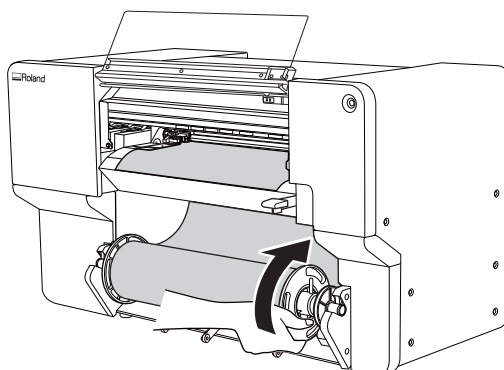

MEMO

When taking up the media (①), ensure that the sensor (②) remains hidden.

Setup of Registered Media

If you take up too much media and make the sensor visible, you will hear two short beeps and the suction fan will stop. If the media comes off or is not straight, take up the media and redo the procedure from step 4.

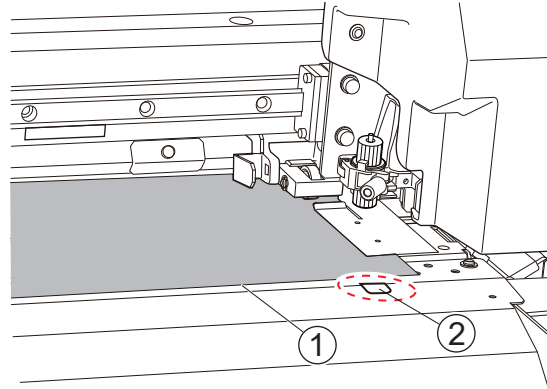

5. Place the left media clamp and the left pinch roller.

Place the left pinch roller (②) within the grit pattern (①).

Ensure that margin A from the left edge of the media to the left edge of the left pinch roller is at least 10 mm (0.39 in.).

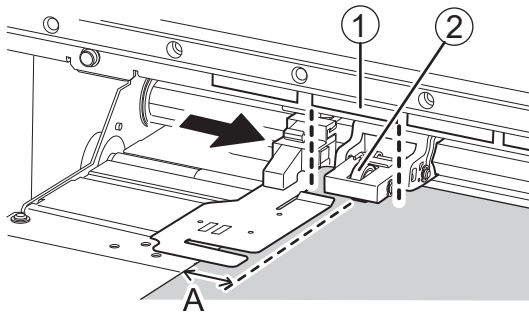

6. Lower the loading lever.

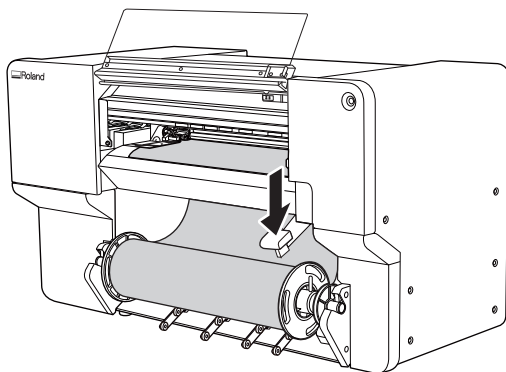

7. Line up the edges of the media with the centers of the holes of the left media clamp.

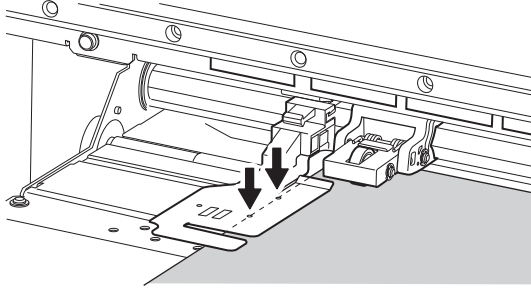

8. Close the front cover.

2. B: Determining the Positions of Media (If [Media Edge Detection Method]: Off)

This section describes how to determine the positions of the media without using the suction fan. Use this method in the following situations.

- When you are using transparent media whose edges cannot be detected.
- When [Enable Detection] under [Preferences]>[Media Edge Detection Method] is set to off.

Procedure

1. Open the front cover.

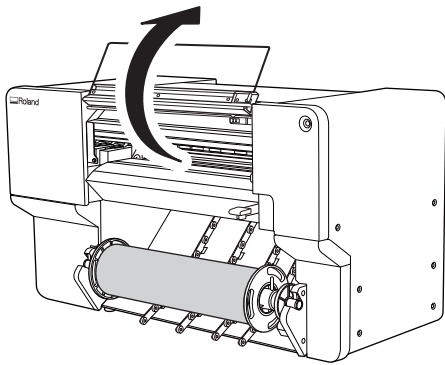

2. Move the right pinch roller (①) and the right media clamp (②) to the right end.

Press the part indicated by the arrow on the right pinch roller to move the roller and the right media clamp together.

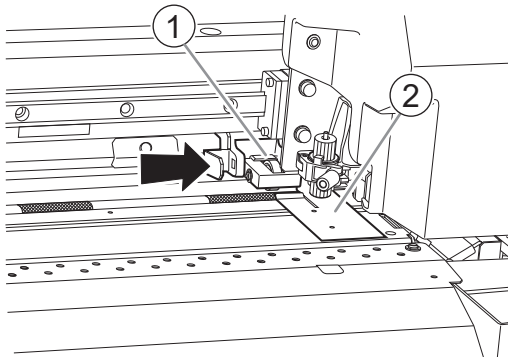

3. Move the left pinch roller (①) and the left media clamp (②) to the left end.

Press the part indicated by the arrow on the left pinch roller to move the roller and the left media clamp together.

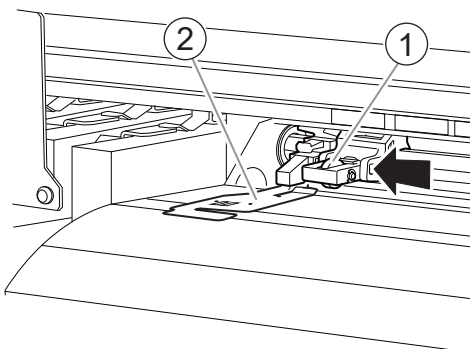

4. Use the following procedure to load the media.

- (1) Pull out the media and load it from above the plate in front with the arrow stickers.

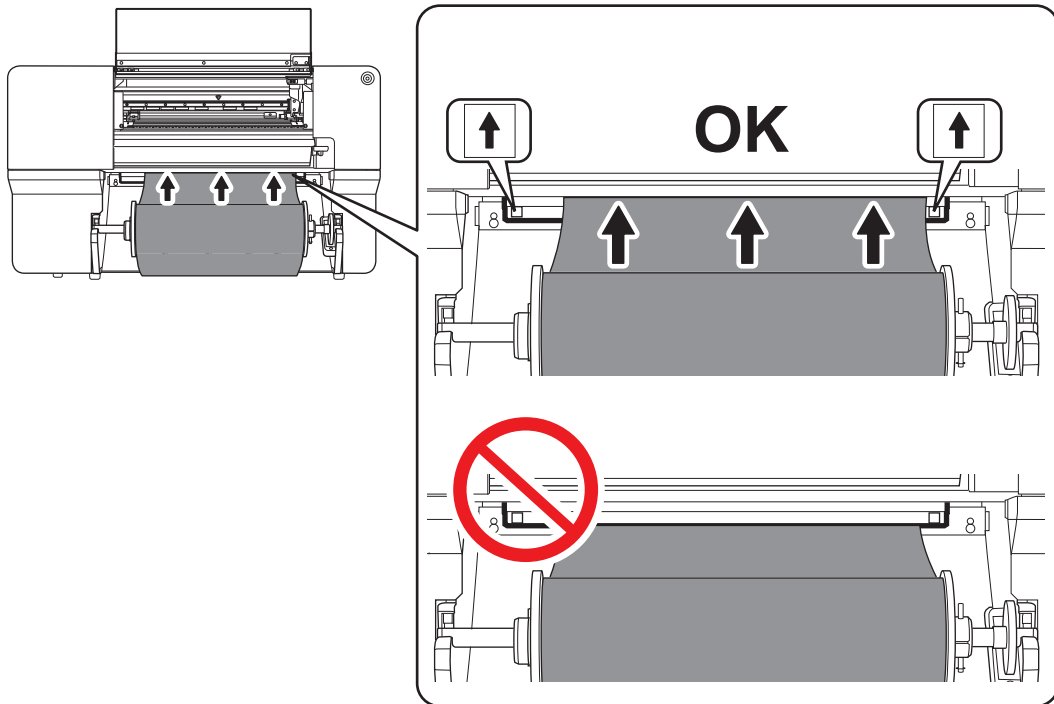

- (2) Pass the media (①) between the right grit roller (②) and right pinch roller (③).

MEMO

If the left edge of the media is left of the left pinch roller, pass the media between the left grit roller and left pinch roller as well.

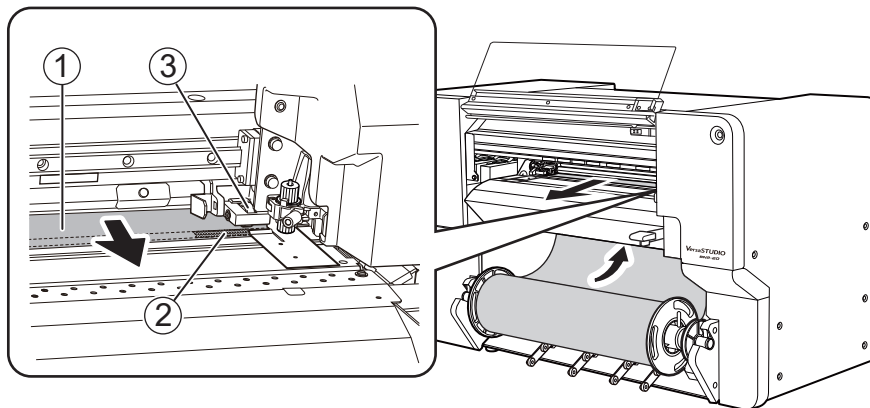

- (3) Pass the media (①) under the right media clamp (②), and pull it out about 20 cm (7.87 in.) from the edge of the apron (③).

MEMO

If the left edge of the media hits the left media clamp, pass the media under the left media clamp.

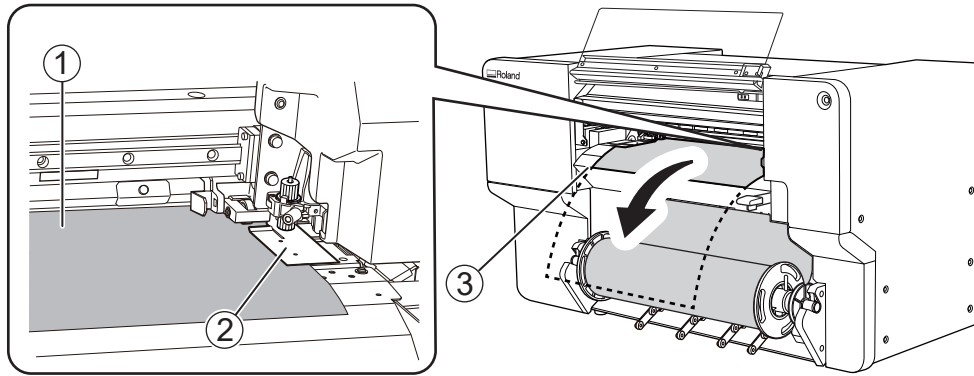

- (4) While lightly holding down the media, hold a media holder flange and take up approximately 20 cm (7.87 in.) of media.

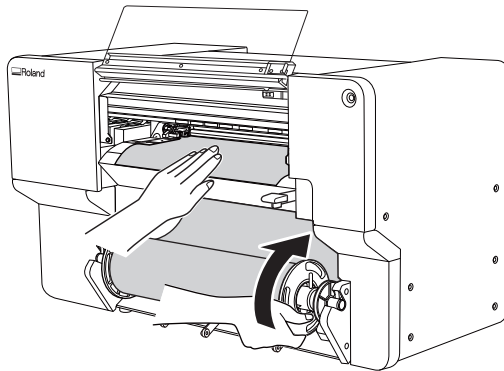

5. While lightly holding down the media by hand, position the left media clamp and the left pinch roller.

Place the left pinch roller (2) within the grit pattern (1).

Ensure that margin A from the left edge of the media to the left edge of the left pinch roller is at least 10 mm (0.39 in.).

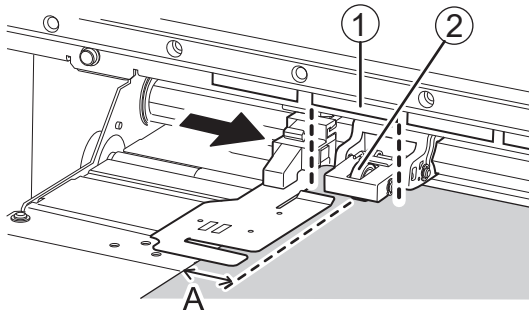

6. Lower the loading lever.

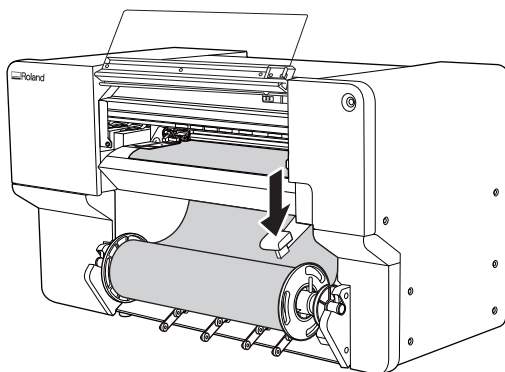

7. Line up the edges of the media with the centers of the holes of the left media clamp.

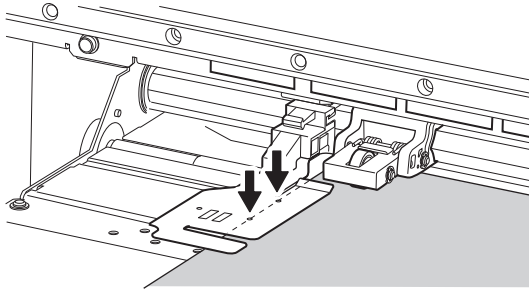

8. Close the front cover.

3. Select the media.

Procedure

1. Click  [Setup].

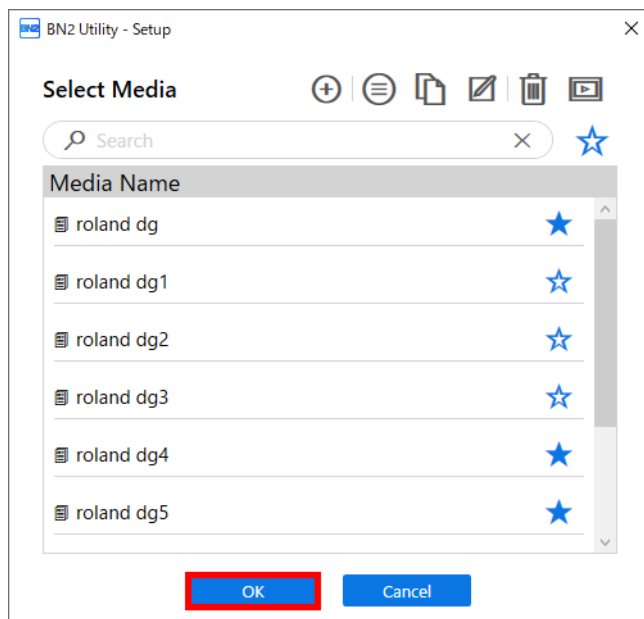

The registered media is displayed in a list.

2. Select the media to use from the list of registered media, and then click [OK].



MEMO

You can search for a media name with the search box. Furthermore, you can set commonly used media as favorites and display only these favorites. You can also search while favorites are displayed.

1. Click  next to a media name to change this icon to .
2. Click  next to the search box.

The icon changes to , and the list of media set as favorites appears.

Click  again to display the list of all media.

3. When the [Load the media, and then make sure that the loading lever is lowered. Start setup.] window appears, click [Off].

The print-head carriage moves, performing the setup operation.

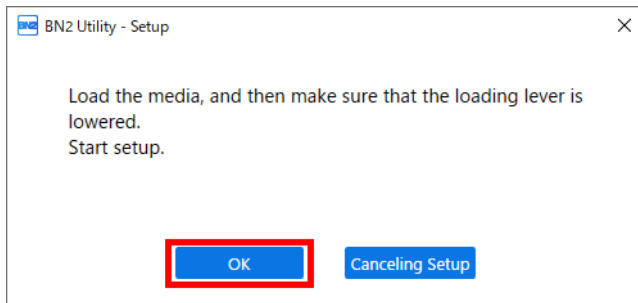
**MEMO**

Setup is not possible if a cover is open or the loading lever is raised. Close the covers and lower the loading lever.

If an error appears, check the error message, clear the error, and then click [OK].

[P. 283 Error Messages](#)

MEMO

After clearing the error, if a setup error occurs, click [OK].

Setup of Sheet Media

Load the sheet media on the printer. When the loading is finished, [Output possible.] is displayed as the status. This work is referred to as "Setup of Media."

1. Determining the Positions of the Media

When loading sheet media in the machine, use the right edge of the media as a reference. This is because the range of movement of the right pinch roller is fixed.

Place the media in a position where the following conditions are met and where media waste will be minimized.

- Position of right edge of media

Within the right pinch roller movable range and where about 10 mm (0.39 in.) between the right roller edge of the right pinch roller and the right edge of the media can be secured.

- Position of left edge of media

Where about 10 mm (0.39 in.) between the left edge of the roller and the left edge of the media can be secured when placing the left pinch roller within the range of the grit pattern.

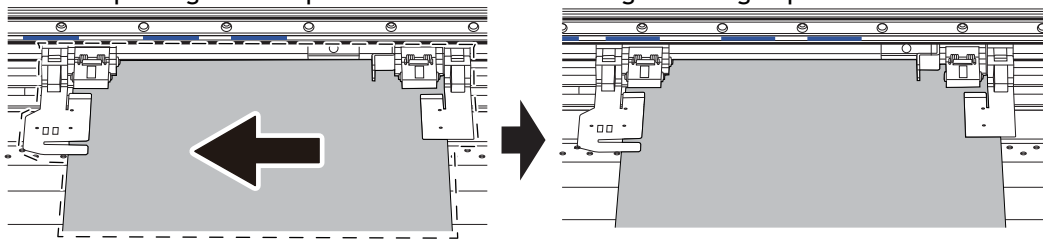

MEMO

Use the following link to view a reference video for this procedure. We recommend that you view this video to understand the overall flow of work.

<https://vimeo.com/1003475093/b41e56efdf>

The BN2-20/20A is shown in this video, but the work and operation procedures are the same for this machine.

Procedure

1. Open the front cover.

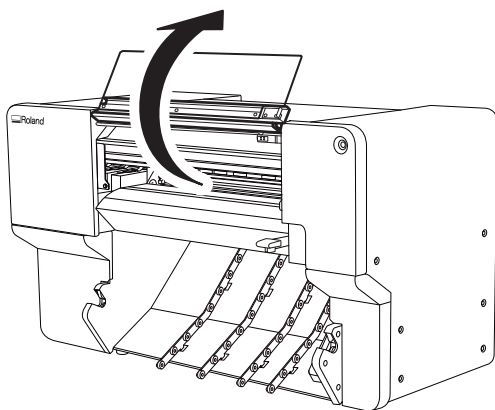

2. Move the right pinch roller (①) and the right media clamp (②) to the right end.

Press the part indicated by the arrow on the right pinch roller to move the roller and the right media clamp together.

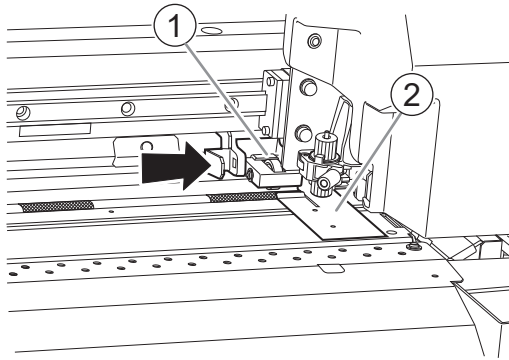

3. Move the left pinch roller (①) and the left media clamp (②) to a position farther left than the media width.

Press the part indicated by the arrow on the left pinch roller to move the roller and the left media clamp together.

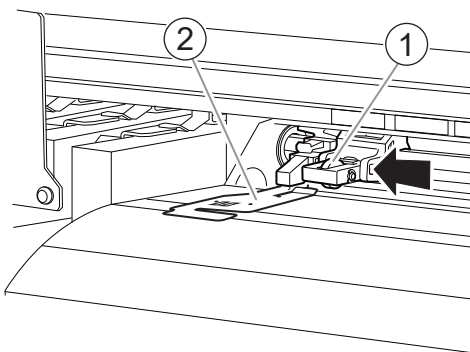

4. Use the following procedure to load the media.

- (1) Pass the media (①) under the right media clamp (②).

MEMO

If the left edge of the media hits the left media clamp, pass the media under the left media clamp.

MEMO

Lifting the tip of the media clamp to pass the media through may cause the blade to come into contact with the media. Be careful not to allow contact with the blade.

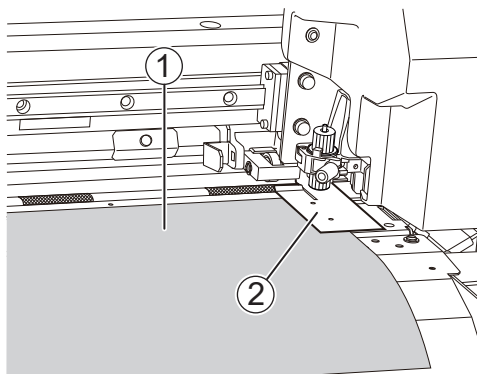

- (2) Pass the media (①) between the right grit roller (②) and the pinch roller (③) and feed the media to the back.

Feed the media and line up the edge of the media with the edge of the apron (④).

MEMO

If the left edge of the media is left of the left pinch roller, pass the media between the left grit roller and left pinch roller as well.

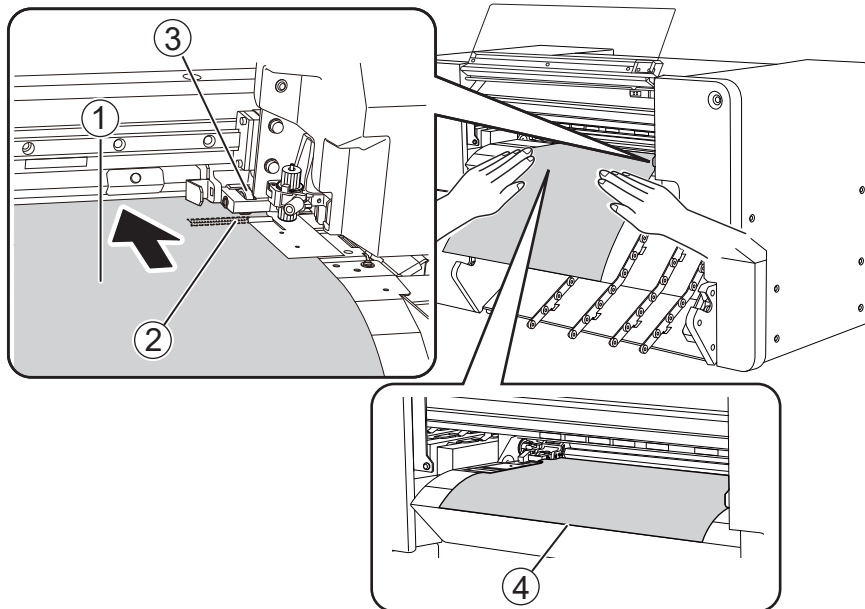

5. Straighten the media.

OK

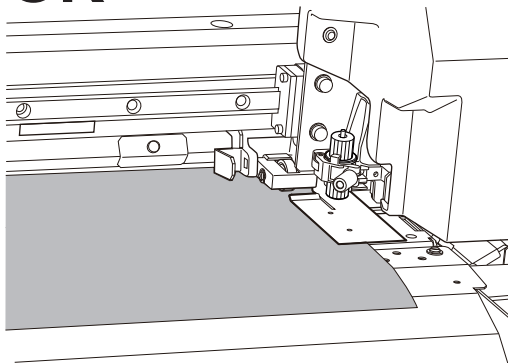

Not OK

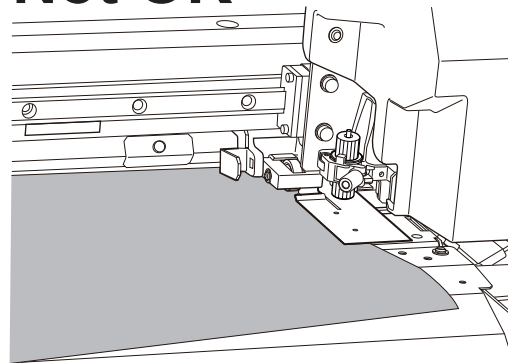

6. Press lightly on the media, and place the left media clamp and left pinch roller on the media.

(1) Position the left pinch roller (2) within the range of the grit pattern (1).

Ensure that margin A from the left edge of the media to the left edge of the left pinch roller is at least 10 mm (0.39 in.).

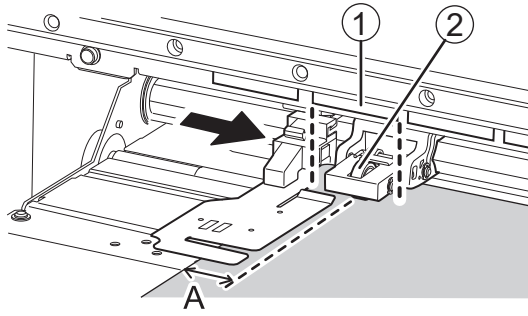
**MEMO**

If at least 10 mm (0.39 in.) cannot be ensured for margin A from the left edge of the media to the left edge of the left pinch roller, move the right pinch roller and the media to the left to provide the margin.

The range of motion of the right pinch roller is fixed. Place the right pinch roller within the movable range in a position that ensures margin A from the right edge of the media to the right edge of the right pinch roller is about 10 mm (0.39 in.).

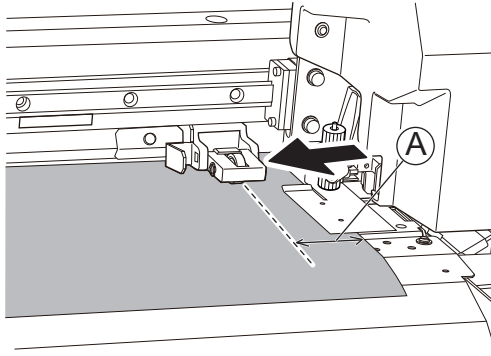

(2) **Adjust the right media clamp position as necessary.**

Click  > [Preferences] > [Media Clamp Position] > [Execute] to move the print-head carriage to the left side, allowing you to adjust the right media clamp position.

Line up the edge of the media with the centers of the holes of the right media clamp.

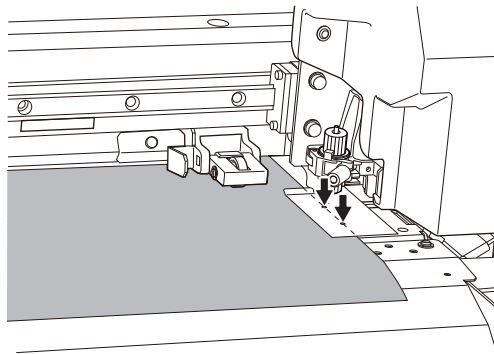

7. Lower the loading lever.

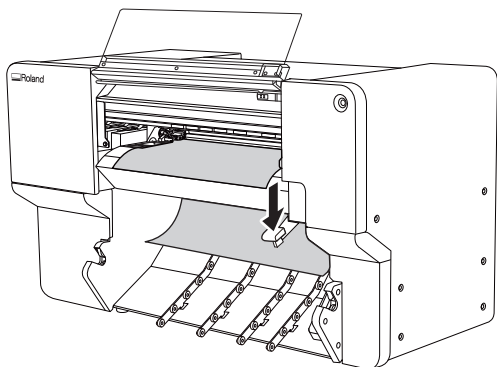

8. Line up the edges of the media with the centers of the holes of the left media clamp.

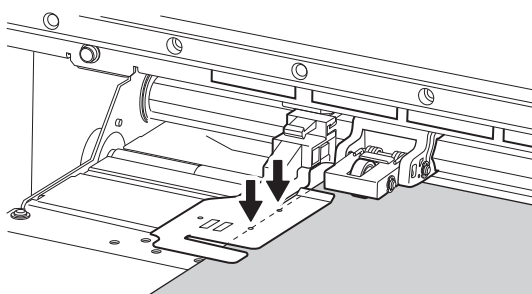

9. Feed the media in the feed direction, checking that the media stays aligned with the pinch rollers.

- (1) On the home screen, click .

The [Move] window appears.

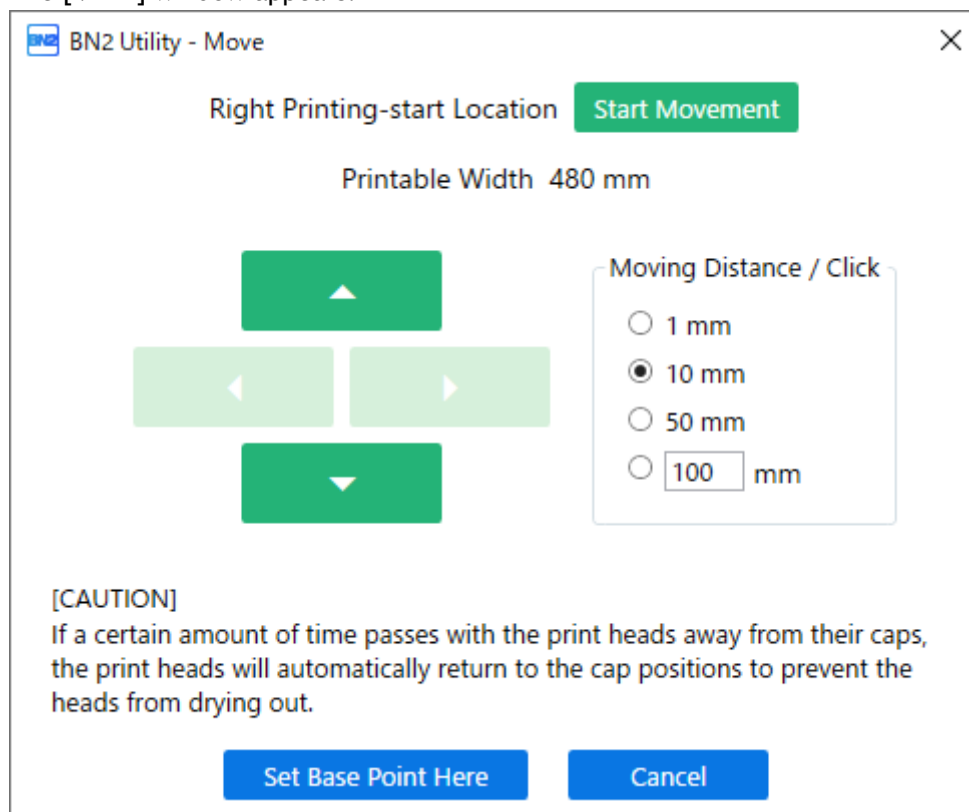

- (2) Select an option under [Moving Distance / Click], and then click .

Feed approximately 2/3 of the length of the media and check that the media stays aligned.
If the media comes off or is not straight, redo the procedure from step 4.

(3) Click  to return to the position before feeding.

If the media comes off or is not straight, redo the procedure from step 4.

10. Click [Cancel].

The [Move] window closes.

11. Close the front cover.

2. Select the media.

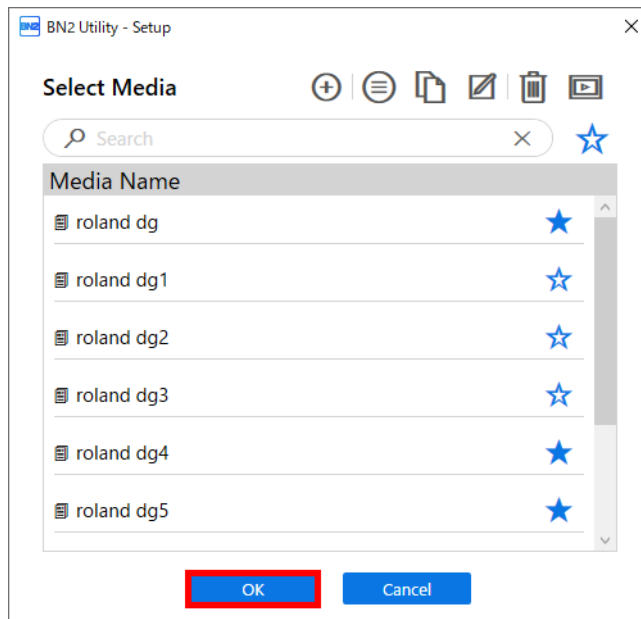

Procedure

1. Click  [Setup].
The registered media is displayed in a list.
2. Select the media to use from the list of registered media, and then click [OK].



MEMO

You can search for a media name with the search box. Furthermore, you can set commonly used media as favorites and display only these favorites. You can also search while favorites are displayed.

1. Click  next to a media name to change this icon to .
2. Click  next to the search box.

The icon changes to , and the list of media set as favorites appears.

Click  again to display the list of all media.

3. When the [Load the media, and then make sure that the loading lever is lowered. Start setup.] window appears, click [Off].

The print-head carriage moves, performing the setup operation.

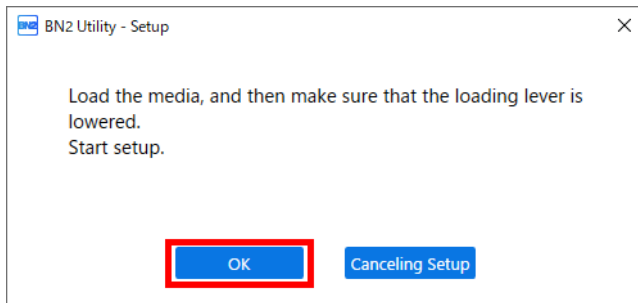
**MEMO**

Setup is not possible if a cover is open or the loading lever is raised. Close the covers and lower the loading lever.

If an error appears, check the error message, clear the error, and then click [OK].

[P. 283 Error Messages](#)

MEMO

After clearing the error, if a setup error occurs, click [OK].

Checking before Output

LAN (Local Area Network) Settings

Check that you can perform communication through the LAN (Local Area Network).

The LAN is enabled if the status LED on the LAN connector located on the side of the printer is lit in green.

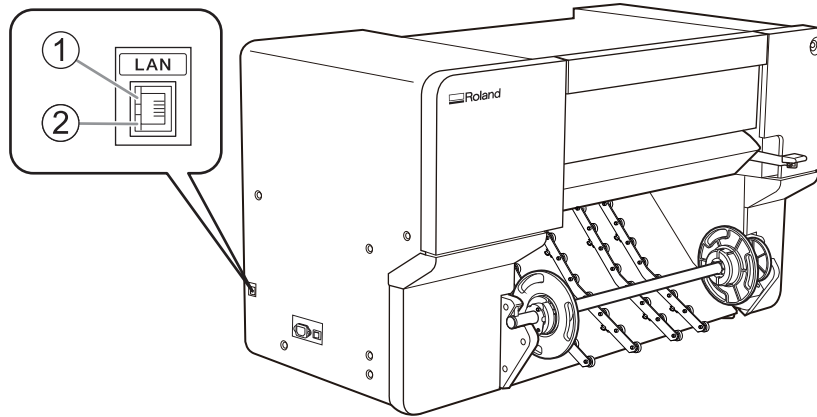

①	Activity LED	This flashes orange while data is being received from the network.
②	Status LED	This indicates the status of the communication function. When it lights in green, communication is possible.

Preventing Sedimentation in Inks

The precipitation of the ingredients in the ink disables printing in normal color. So that the ink mixes well, shake the ink cartridge horizontally with a stroke length of around 5 cm (1.97 in.) from each end of the ink cartridge.

Shake the ink cartridges:

- All inks: When replaced with a new product.
All inks: 100 times (40 seconds)
- White ink: Each day (before starting the day's operations).
 - Remove the white ink cartridge, shake it 100 times (about 40 seconds), and then reinsert this cartridge.
 - After a period of no use for 24 hours or more, such as over a weekend, shake the white ink well about 100 times before use.

The ingredients in white ink tend to settle. Each day, before starting the day's operations, be sure to shake this cartridge. Allowing the ink to stand can cause the settled material to harden, resulting in malfunctions or other problems.

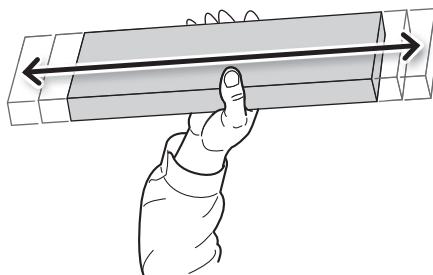

IMPORTANT

- Before shaking the ink cartridge, wipe off any ink from around its mouth. If you do not wipe off the ink, it may splatter when you shake the ink cartridge.
- When you have finished mixing the ink, reattach the ink cartridge immediately. Taking time to reattach the ink cartridge will adversely affect the ink path.

Pausing and Canceling Output

You can pause and cancel output before it finishes.

Pausing and Resuming Output

IMPORTANT

We do not recommend resuming printing.
When printing pauses, horizontal bands may occur at the paused position.

Procedure

1. During output, click [Pause] on the home screen.
This pauses the printing operation.

MEMO

You cannot operate the home screen while the menu screen is displayed. Close the menu screen.

2. When the following window is displayed, click [Resume].

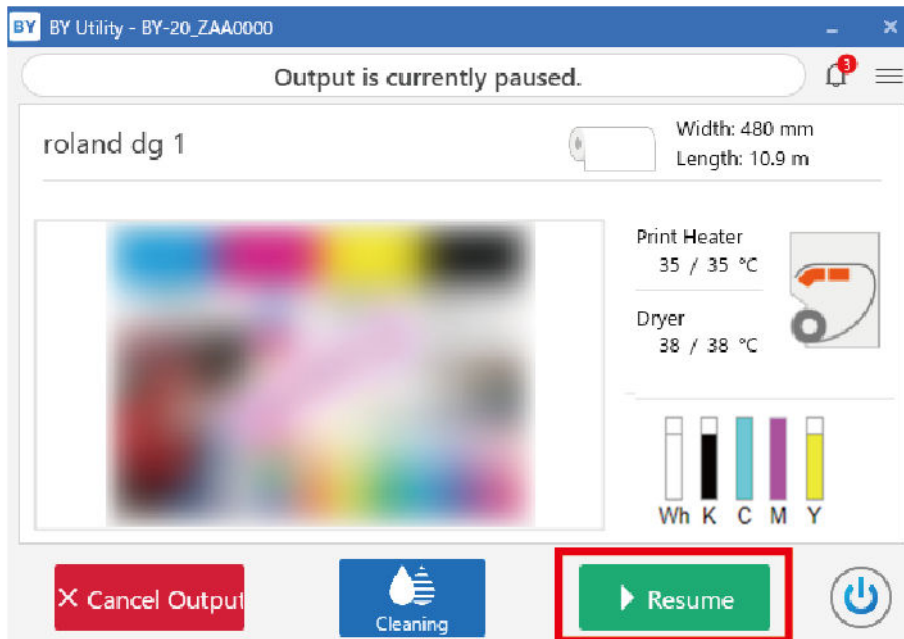

The printing operation resumes.

Canceling Output

Stopping Output in Utility

Procedure

1. During output, click [Pause].
This pauses the printing operation.
2. When the following window is displayed, click [Cancel Output].

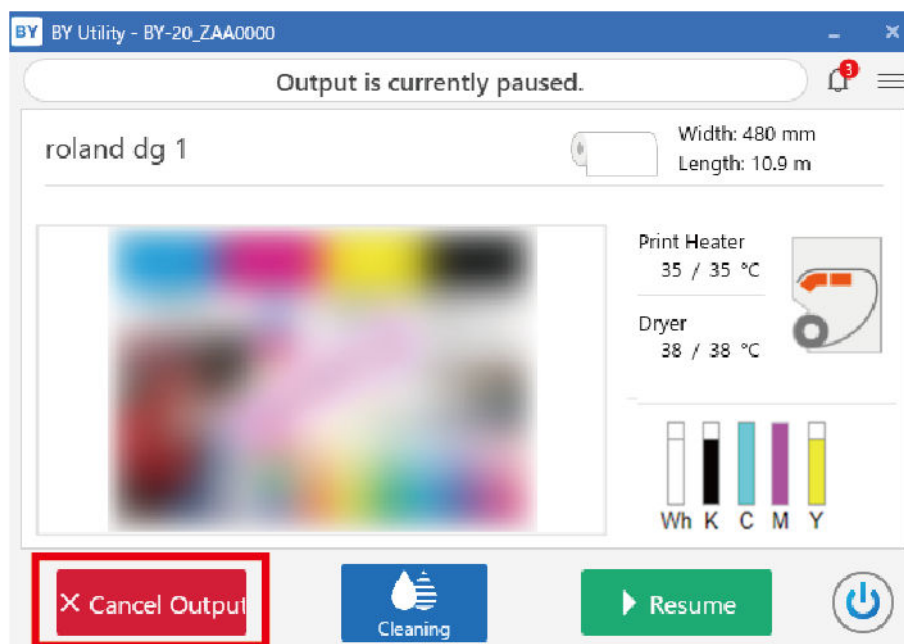

3. In the confirmation window, click [OK].
Output is canceled.

Stopping Output on the Printer Side

Procedure

1. Hold down the sub power button for 1 second or longer during output.
Output is stopped, and the sub power of the machine switches off automatically. You cannot resume output from the point it was canceled.

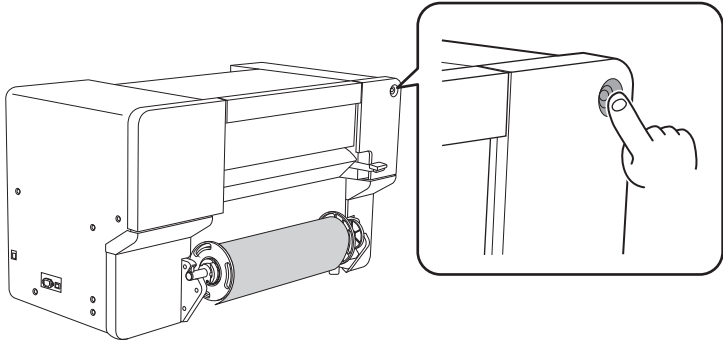

- 2. Press the sub power button to turn the sub power on.

Separating the Media

Separate the media with [Sheet Cutting] after printing. Alternatively, perforate the media without separating it with [Perforated Sheet Cutting].



Before using [Sheet Cutting] or [Perforated Sheet Cutting], check that the left and right media clamps are attached correctly.

MEMO

Check that the left media clamp is positioned correctly above the media.
If it is not positioned correctly, uncut areas may remain on the media or the media may be jammed due to it getting caught in the machine.

Procedure

1. Close the front cover.
2. If necessary, use the following procedure to set the separation position.

- (1) On the home screen, click  [Move].
- (2) Select [Moving Distance / Click].
- (3) Click Start moving[Start Movement].
- (4) Click  or  to set the media to the separation position.

The media separation position is the blade protector position (①) in this situation. During actual operation, the set separation position is fed to the position of the separating groove (②), and the media is separated. Use the notch on the left media clamp as a guideline for this position.

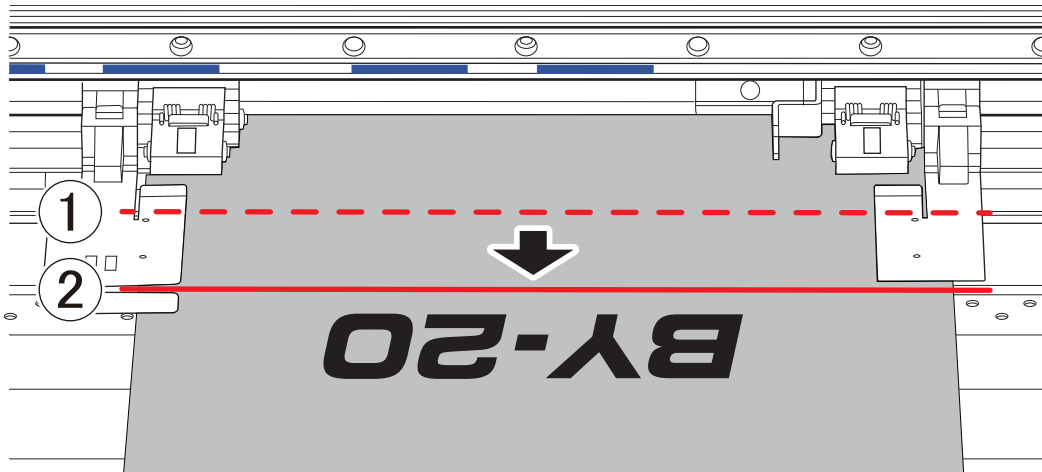

- (5) Click [Set Base Point Here].
The separation position is set, and you are returned to the home screen.

3. Click  [Sheet Cutting].

4. Select the sheet cutting method, and then click [OK].

[Sheet Cutting]	This separates the media.
[Perforated Sheet Cutting]	The media is perforated without being separated.

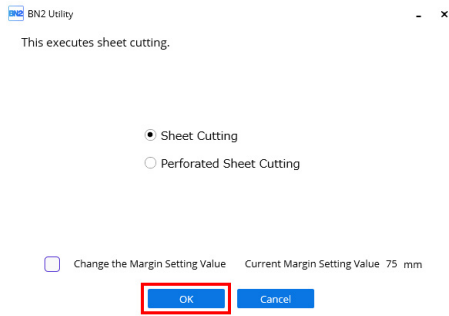

IMPORTANT

Separation Operations

- If the distance from the end of the media to the separation location is short, separation may not be performed smoothly.

Give Attention to the Media Composition

- For some types of media, separation is not possible.
- Some types of media may remain on the platen after separation. If the media remains on the platen, remove it by hand.

Output Method

Printing Method

Preparations for Output	95
Step 1: Performing a Nozzle Drop-out Test	95
Step 2: Normal Cleaning Method	97
Starting Print Output	99

Preparations for Output

Step 1: Performing a Nozzle Drop-out Test

Before you carry out actual printing, perform a printing test to ensure no dot drop-out or dot displacement occurs. If dot drop-out or dot displacement occurs, perform cleaning of the print heads (normal cleaning).

MEMO

When performing printing tests successively, you can select [Vertical Printing] or [Horizontal Printing] as the printing position for the second and later tests in comparison to the first test.

[P. 194 Performing Printing Tests Arranged Horizontally](#)

MEMO

Use the following link to view a reference video for this procedure. We recommend that you view this video to understand the overall flow of work.

<https://vimeo.com/1003475749/6df9f81a6c>

The BN2-20/20A is shown in this video, but the work and operation procedures are the same for this machine.

Procedure

1. On the home screen, click  [Cleaning].

2. Click [Output].

Printing of the test pattern starts.

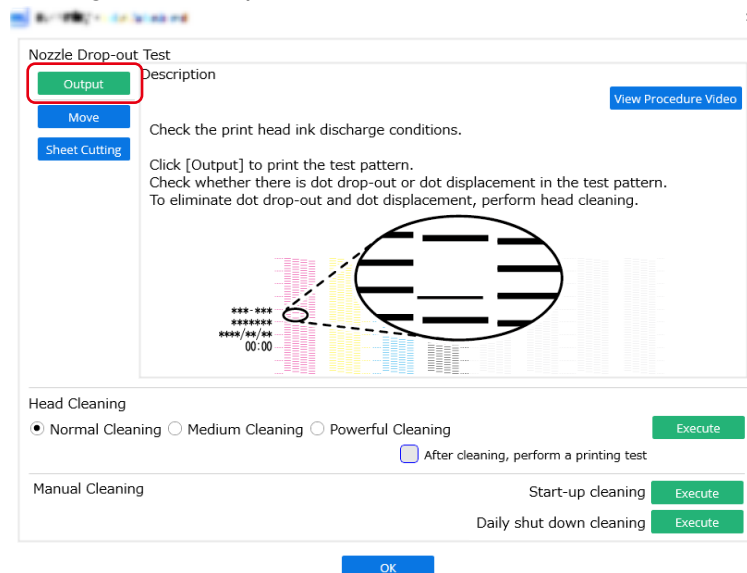

3. Check whether there is dot drop-out or dot displacement in the test pattern.

Missing blocks indicate dot drop-out. Collapsed or inclined blocks indicate dot displacement.

If dot drop-out or dot displacement is present, proceed to [Step 2: Normal Cleaning Method](#) and perform normal cleaning. Also, if dot drop-out is present in multiple locations within a row, see the procedure in [Handling Severe Dot Drop-out](#).



MEMO

Even if nozzle drop-out does not appear to be improved by cleaning, it may be possible to ignore the effect on products if drop-out occurs in just a few locations. Try printing. If you can judge that the product is not affected, use the printer without any further cleaning.

4. If you have opened the front cover, close it.
If no dot drop-out or dot displacement occurs, preparations for output are finished.
5. Click [Close] to return to the original window.

Step 2: Normal Cleaning Method

MEMO

If the media has already been set up, the [After cleaning, perform a printing test] menu appears. When this is turned on, a printing test is performed after cleaning.

Procedure

1. Select [Normal Cleaning] under [Head Cleaning], and then click [Execute].

The status is displayed as [Cleaning in progress.].

An estimate for the remaining cleaning time is displayed at the top of the Utility home screen.

On completion, you will return to the original window.

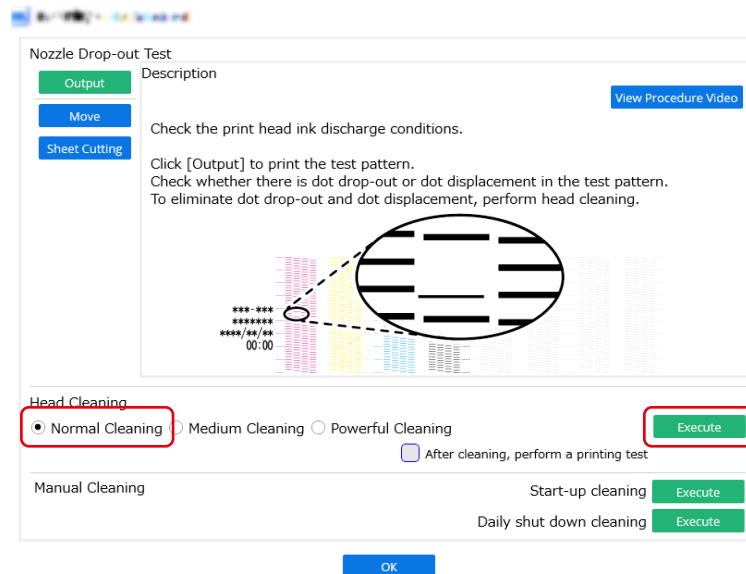

2. Click [Output].

Printing of the test pattern starts.

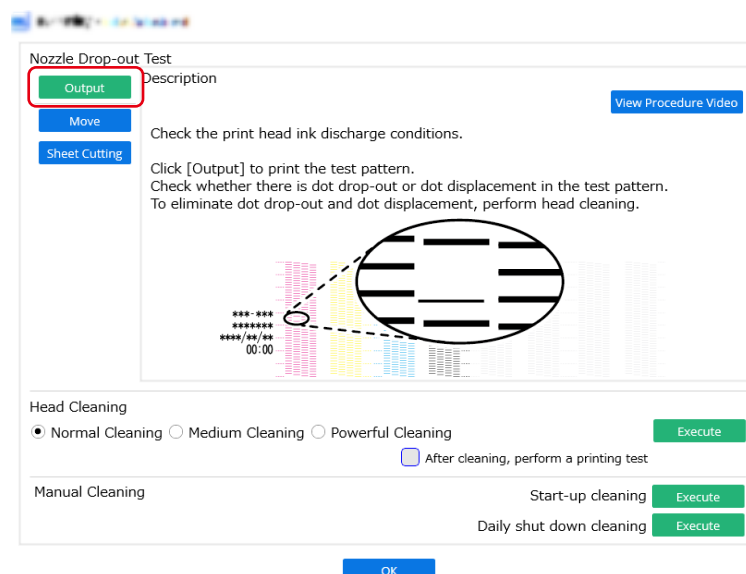

3. Check whether there is dot drop-out or dot displacement in the test pattern.

Missing blocks indicate dot drop-out. Collapsed or inclined blocks indicate dot displacement.

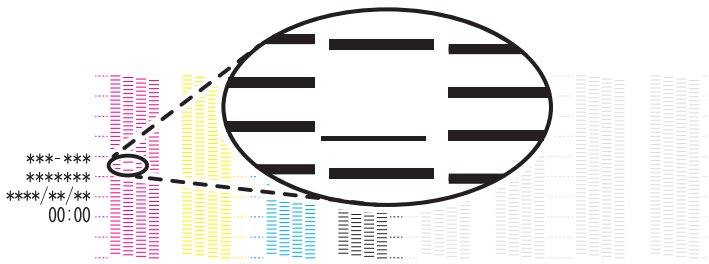

MEMO

- If the problem persists, try performing normal cleaning again.
- If problems such as dot drop-out and dot displacement persist even after you have performed normal cleaning several times, use a different cleaning method.

4. If you have opened the front cover, close it.
If no dot drop-out or dot displacement occurs, preparations for output are finished.
5. Click [Close] to return to the original window.

RELATED LINKS

- [P. 234 Medium Cleaning](#)
- [P. 236 Powerful Cleaning](#)

Starting Print Output

⚠ CAUTION

Never insert your hand or fingers into the opening of the front cover.

The print head carriage moves at high speed inside the cover. Coming into contact with the moving carriage may cause injury.

Procedure

1. Prepare the print data.

2. Output the print data.

- **Outputting from Designer**

Refer to the "[Designer User's Manual](#)."

MEMO

Using Designer

Click the Designer icon in Roland DG Connect Hub.

If the Roland DG Connect login screen is displayed, enter your email address and password to log in.

- **Outputting from VersaWorks**

See the "[First Step Guide](#)."

3. Once output is complete, click  [Sheet Cutting].

4. Select the sheet cutting method, and then click [OK].

[Sheet Cutting]	This separates the media.
[Perforated Sheet Cutting]	The media is perforated without being separated.

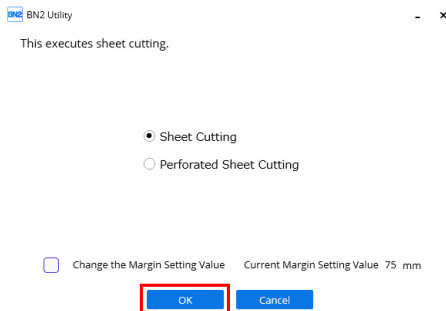

IMPORTANT

Output is not possible in these situations

- The machine does not run when the front, left, or right cover is open.
- Output does not start until the heater reaches the specified temperature.
When the ambient temperature is low, the heater is slow to warm up. Use the machine in an environment where the temperature is 20°C to 28°C (68°F to 82.4°F).
- With the setup of media complete, output is not performed when the sub power button's indicator is not lit in yellow or is not blinking in blue (indicating sleep mode).
- A warning beep goes off and output is not performed when an ink cartridge becomes empty. A message indicating that ink has run out is displayed in the Status field in the Utility window. Replace the empty ink cartridge with a new one, and then send the output data.

Points that must be observed

- Never open the front, left, or right cover while output is in progress. Doing so interrupts printing.
- When you are performing printing, clamp the edges of the media with the media clamps. Otherwise, the edges of the media may warp and catch on the print heads.
- During output, do not touch the media. Doing so may obstruct the media feed or cause the media to rub against the print heads, which may result in a paper jam or damage to the heads.
- Keep the loading lever raised when the machine is not in use.

When not using the machine, remove any media and store it in a suitable environment.

- If the machine is left with the media loaded, the media may be damaged, which may adversely affect printing. When not using the machine, remove any media and store it in a suitable environment.

RELATED LINKS

- [P. 88 Pausing and Resuming Output](#)
- [P. 89 Canceling Output](#)

Cutting Method

Preparations for Output	102
Step 1: Switching Off the Print Heater and Dryer	102
Step 2: Preventing Pulling of the Media with Undue Force	103
Step 3: Adjusting Cutting	104
Starting Print Output.....	106

Preparations for Output

Step 1: Switching Off the Print Heater and Dryer

Procedure

1. On the Utility home screen, click the following part.

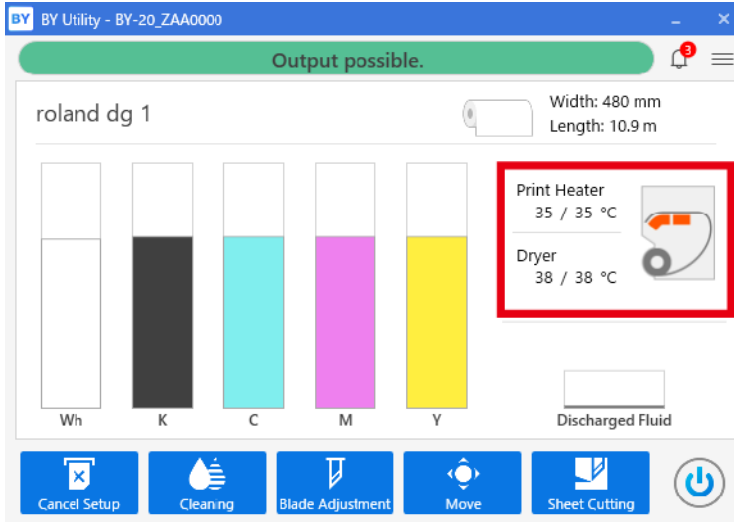

2. Clear the [Enable Print Heater] and [Enable Dryer] check boxes.

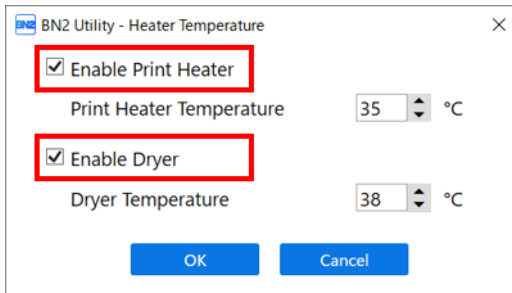

3. Click [OK] to confirm your entry.
The [Print Heater] and [Dryer] settings turn off.

Step 2: Preventing Pulling of the Media with Undue Force

Procedure

1. Click .
2. Select the [Preferences]>[Prefeeding at Output]>[Enable Prefeeding] check box.

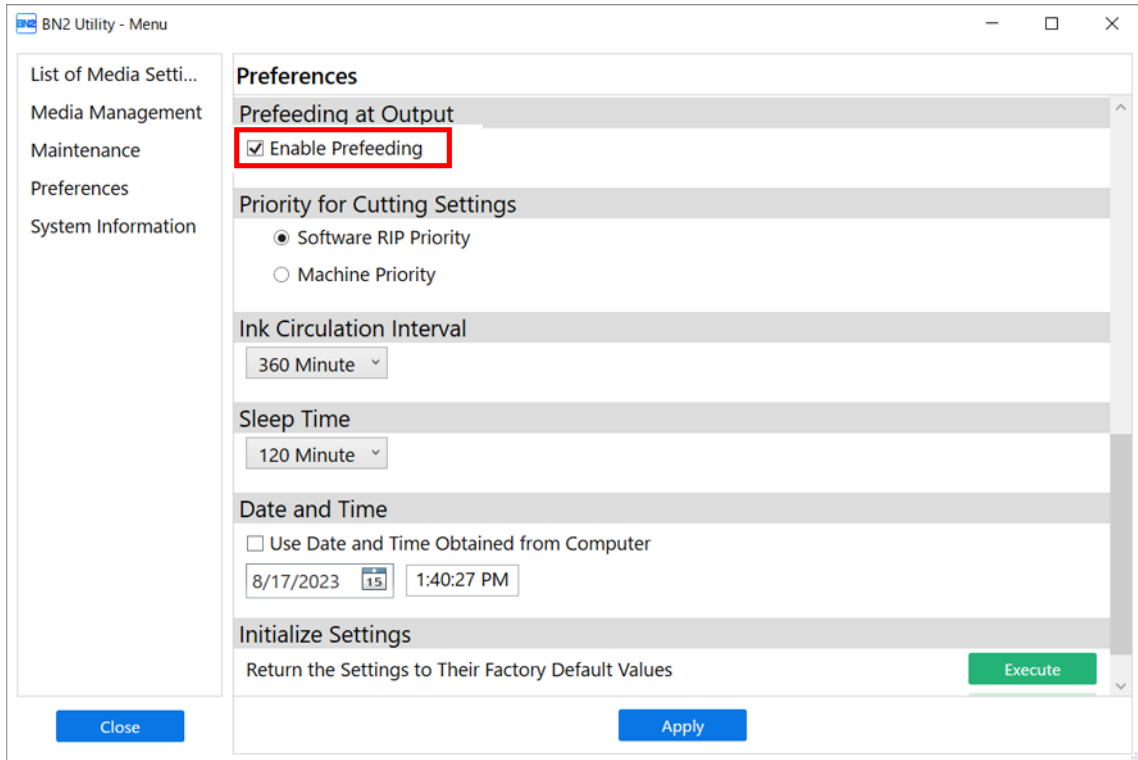

3. Click [Apply] to confirm your entry.
4. Click [Close] to return to the original screen.

Step 3: Adjusting Cutting

For high-quality cutting, we recommend carrying out a cutting test to check the cutting quality for the media before you perform actual cutting. Adjust the blade force depending on the cutting quality.

MEMO

Use the following link to view a reference video for this procedure. We recommend that you view this video to understand the overall flow of work.

<https://vimeo.com/1003474895/208e3298e2>

The BN2-20/20A is shown in this video, but the work and operation procedures are the same for this machine.

Procedure

1. Close the front cover.
2. On the home screen, click  [Blade Adjustment].
3. Click [Output].

The test pattern is cut.

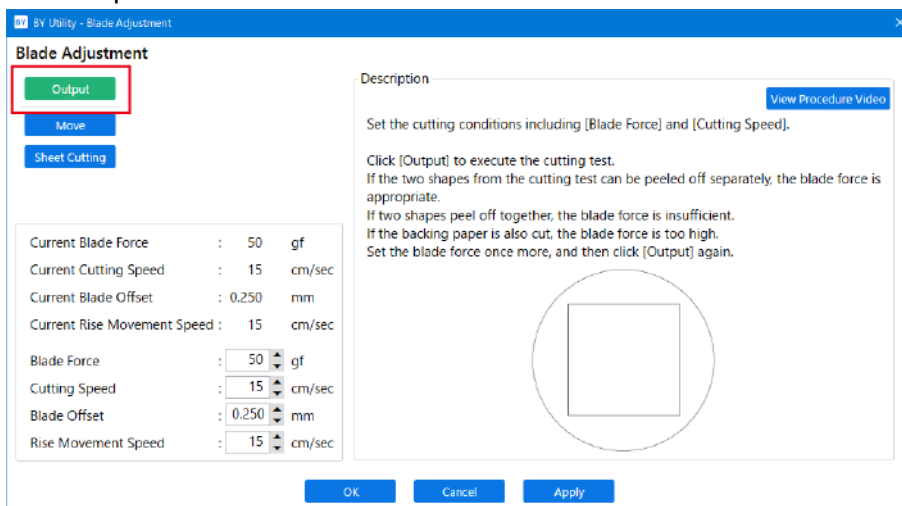

4. Peel off the cut shapes and change the [Blade Force] settings according to the cutting quality.

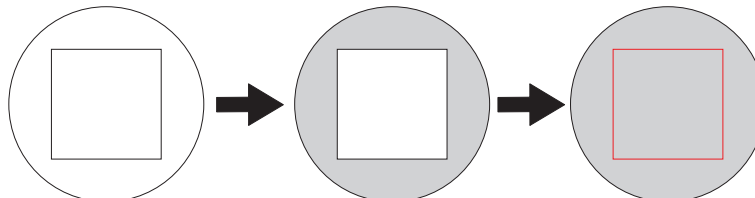

- **Two shapes are peeled off separately**
You do not need to perform the setting because the blade force is appropriate.
- **Two shapes are peeled off together**
Increase the blade force.
- **Backing paper is also cut**
Decrease the blade force.

5. Click [Apply].

The changed settings are saved.

6. Click [Apply] again.

The test pattern is cut.

7. Check whether the correction was successful.

In the [Apply] menu, you can also make settings for other cutting conditions in addition to the blade force.

8. Click [OK] to return to the original screen.

RELATED LINKS

- [P. 157 Accurately Adjusting the Cutting Settings](#)

Starting Print Output

⚠ CAUTION

Never insert your hand or fingers into the opening of the front cover.

The print head carriage moves at high speed inside the cover. Coming into contact with the moving carriage may cause injury.

Procedure

1. Prepare the print data.

2. Output the print data.

- **Outputting from Designer**

Refer to the "[Designer User's Manual](#)."

MEMO

Using Designer

Click the Designer icon in Roland DG Connect Hub.

If the Roland DG Connect login screen is displayed, enter your email address and password to log in.

- **Outputting from VersaWorks**

See the "[First Step Guide](#)."

3. Once output is complete, click  [Sheet Cutting].

4. Select the sheet cutting method, and then click [OK].

[Sheet Cutting]	This separates the media.
[Perforated Sheet Cutting]	The media is perforated without being separated.

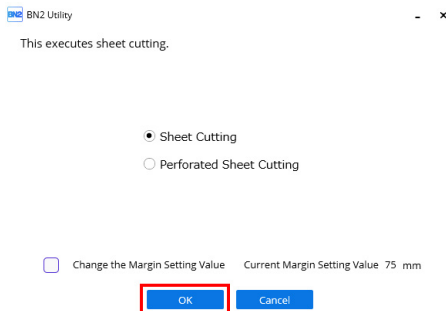

IMPORTANT

Output is not possible in these situations

- The machine does not run when the front, left, or right cover is open.
- With the setup of media complete, output is not performed when the sub power button's indicator is not lit in yellow or is not blinking in blue (indicating sleep mode).
- A warning beep goes off and output is not performed when an ink cartridge becomes empty. A message indicating that ink has run out is displayed in the Status field in the Utility window. Replace the empty ink cartridge with a new one, and then send the output data.

Points that must be observed

- Never open the front, left, or right cover while output is in progress. Doing so interrupts printing.

- When you are performing printing, clamp the edges of the media with the media clamps. Otherwise, the edges of the media may warp and catch on the print heads.
- During output, do not touch the media. Doing so may obstruct the media feed or cause the media to rub against the print heads, which may result in a paper jam or damage to the heads.
- Keep the loading lever raised when the machine is not in use.

When not using the machine, remove any media and store it in a suitable environment.

- If the machine is left with the media loaded, the media may be damaged, which may adversely affect printing. When not using the machine, remove any media and store it in a suitable environment.

RELATED LINKS

- [P. 88 Pausing and Resuming Output](#)
- [P. 89 Canceling Output](#)

Printing and Cutting Method

Preparations for Output	109
Step 1: Performing a Nozzle Drop-out Test	109
Step 2: Normal Cleaning Method	111
Step 3: Adjusting Cutting	113
Step 4: Correcting the Misalignment of Printing and Cutting	115
Starting Print Output	117

Preparations for Output

Step 1: Performing a Nozzle Drop-out Test

Before you carry out actual printing, perform a printing test to ensure no dot drop-out or dot displacement occurs. If dot drop-out or dot displacement occurs, perform cleaning of the print heads (normal cleaning).

MEMO

When performing printing tests successively, you can select [Vertical Printing] or [Horizontal Printing] as the printing position for the second and later tests in comparison to the first test.

[P. 194 Performing Printing Tests Arranged Horizontally](#)

MEMO

Use the following link to view a reference video for this procedure. We recommend that you view this video to understand the overall flow of work.

<https://vimeo.com/1003475749/6df9f81a6c>

The BN2-20/20A is shown in this video, but the work and operation procedures are the same for this machine.

Procedure

1. On the home screen, click  [Cleaning].

2. Click [Output].

Printing of the test pattern starts.

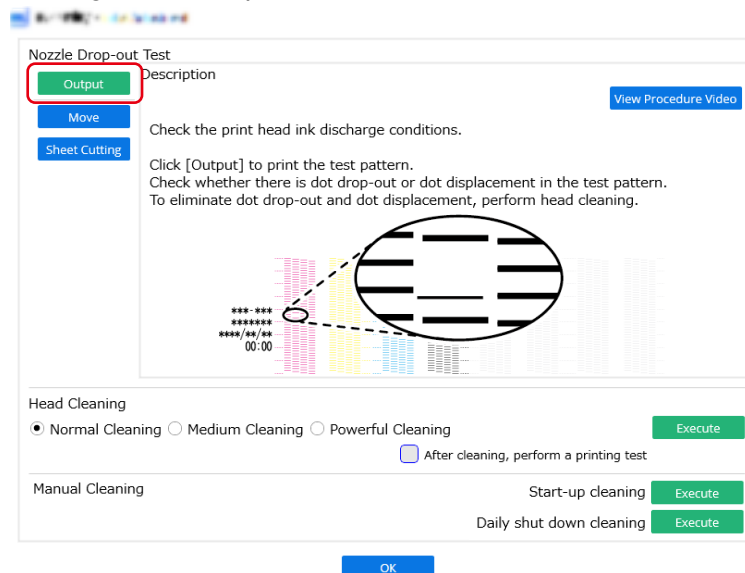

3. Check whether there is dot drop-out or dot displacement in the test pattern.

Missing blocks indicate dot drop-out. Collapsed or inclined blocks indicate dot displacement.

If dot drop-out or dot displacement is present, proceed to [Step 2: Normal Cleaning Method](#) and perform normal cleaning. Also, if dot drop-out is present in multiple locations within a row, see the procedure in [Handling Severe Dot Drop-out](#).



MEMO

Even if nozzle drop-out does not appear to be improved by cleaning, it may be possible to ignore the effect on products if drop-out occurs in just a few locations. Try printing. If you can judge that the product is not affected, use the printer without any further cleaning.

4. If you have opened the front cover, close it.
If no dot drop-out or dot displacement occurs, preparations for output are finished.
5. Click [Close] to return to the original window.

Step 2: Normal Cleaning Method

MEMO

If the media has already been set up, the [After cleaning, perform a printing test] menu appears. When this is turned on, a printing test is performed after cleaning.

Procedure

1. Select [Normal Cleaning] under [Head Cleaning], and then click [Execute].

The status is displayed as [Cleaning in progress.].

An estimate for the remaining cleaning time is displayed at the top of the Utility home screen.

On completion, you will return to the original window.

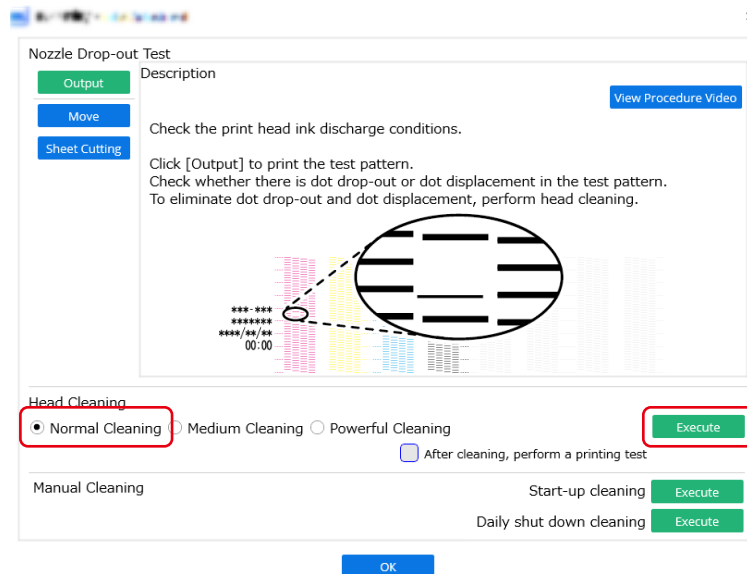

2. Click [Output].

Printing of the test pattern starts.

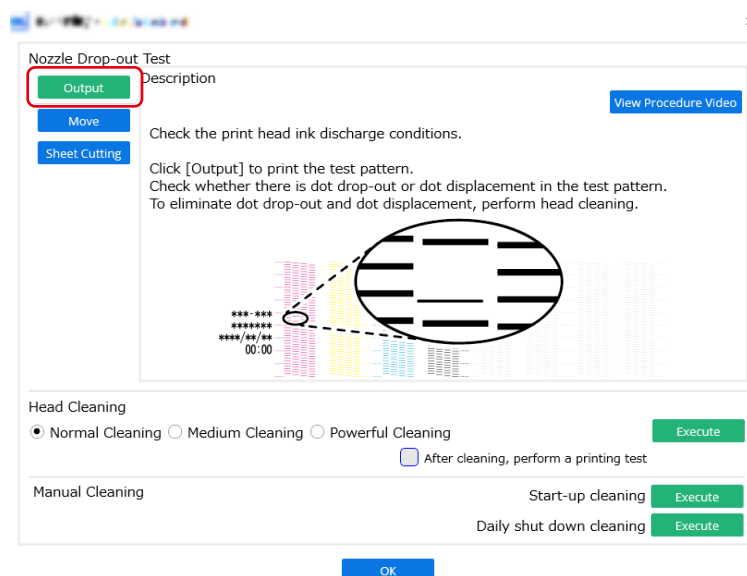

3. Check whether there is dot drop-out or dot displacement in the test pattern.

Missing blocks indicate dot drop-out. Collapsed or inclined blocks indicate dot displacement.

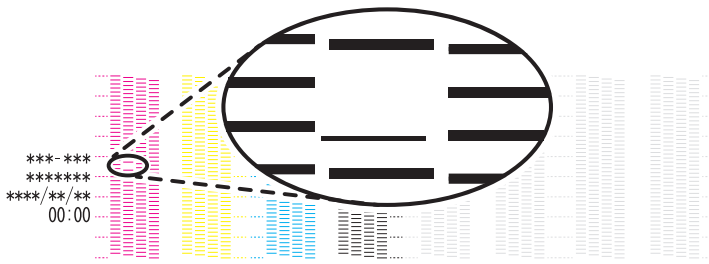

MEMO

- If the problem persists, try performing normal cleaning again.
- If problems such as dot drop-out and dot displacement persist even after you have performed normal cleaning several times, use a different cleaning method.

4. If you have opened the front cover, close it.

If no dot drop-out or dot displacement occurs, preparations for output are finished.

5. Click [Close] to return to the original window.

RELATED LINKS

- [P. 234 Medium Cleaning](#)
- [P. 236 Powerful Cleaning](#)

Step 3: Adjusting Cutting

For high-quality cutting, we recommend carrying out a cutting test to check the cutting quality for the media before you perform actual cutting. Adjust the blade force depending on the cutting quality.

MEMO

Use the following link to view a reference video for this procedure. We recommend that you view this video to understand the overall flow of work.

<https://vimeo.com/1003474895/208e3298e2>

The BN2-20/20A is shown in this video, but the work and operation procedures are the same for this machine.

Procedure

1. Close the front cover.
2. On the home screen, click  [Blade Adjustment].
3. Click [Output].

The test pattern is cut.

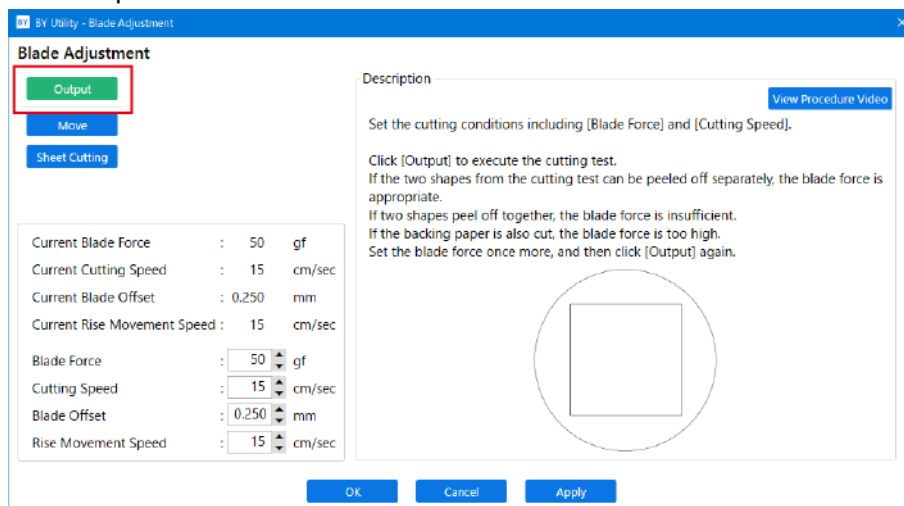

4. Peel off the cut shapes and change the [Blade Force] settings according to the cutting quality.

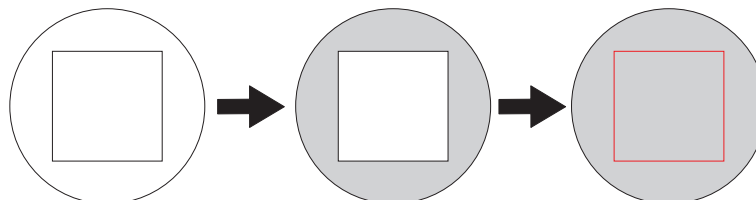

- **Two shapes are peeled off separately**
You do not need to perform the setting because the blade force is appropriate.
- **Two shapes are peeled off together**
Increase the blade force.
- **Backing paper is also cut**
Decrease the blade force.

5. Click [Apply].

The changed settings are saved.

6. Click [Apply] again.

The test pattern is cut.

7. Check whether the correction was successful.

In the [Apply] menu, you can also make settings for other cutting conditions in addition to the blade force.

8. Click [OK] to return to the original screen.

RELATED LINKS

- [P. 157 Accurately Adjusting the Cutting Settings](#)

Step 4: Correcting the Misalignment of Printing and Cutting

This is a correction method performed when printing followed immediately by cutting yields positioning for printing and cutting that is slightly misaligned.

Print alignment marks, perform detection of the printed marks, and then correct the discrepancy. Minor misalignment between the printing and cutting positions may occur due to the thickness of the media. We recommend that you make corrections to match the media you are using.

MEMO

Use the following link to view a reference video for this procedure. We recommend that you view this video to understand the overall flow of work.

<https://vimeo.com/1003475897/fd4a2d1bdd>

The BN2-20/20A is shown in this video, but the work and operation procedures are the same for this machine.

Procedure

1. Click .
2. Click [Execute] under [List of Media Settings]>[Print & Cut Position Adjustment].

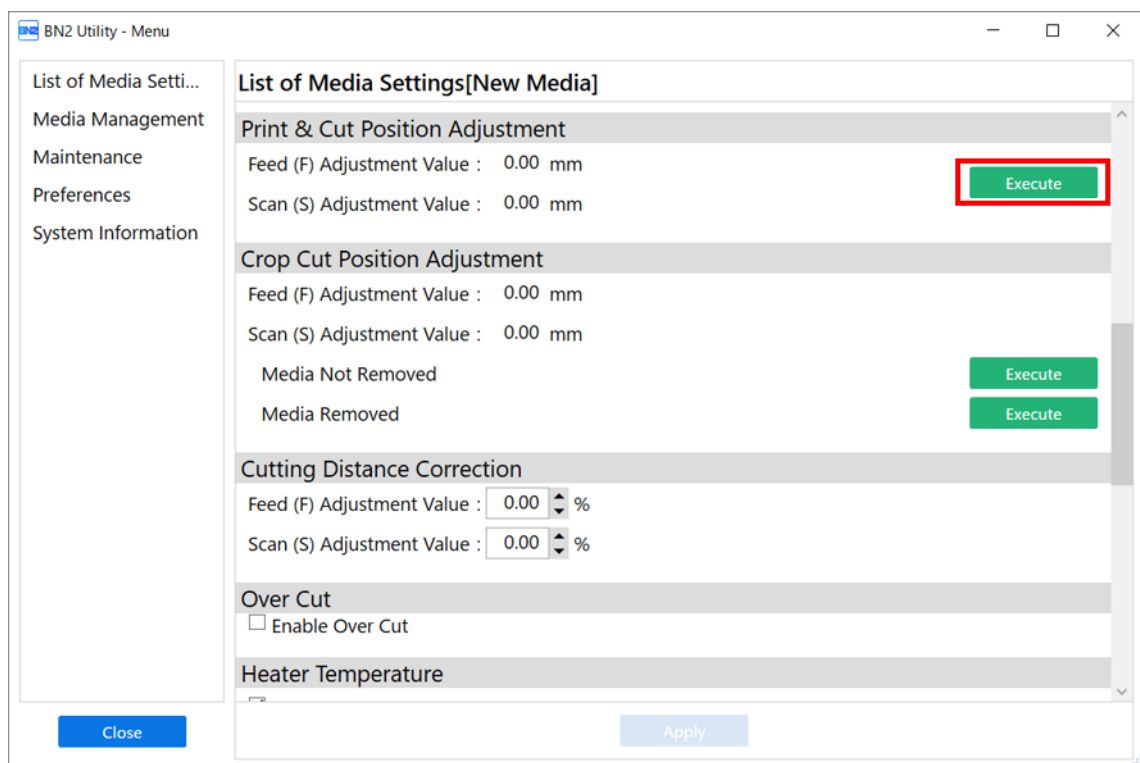

3. Click [Output 1].
The machine prints and cuts the test pattern. View the printing result, checking for misalignment in the printing position and cutting position.

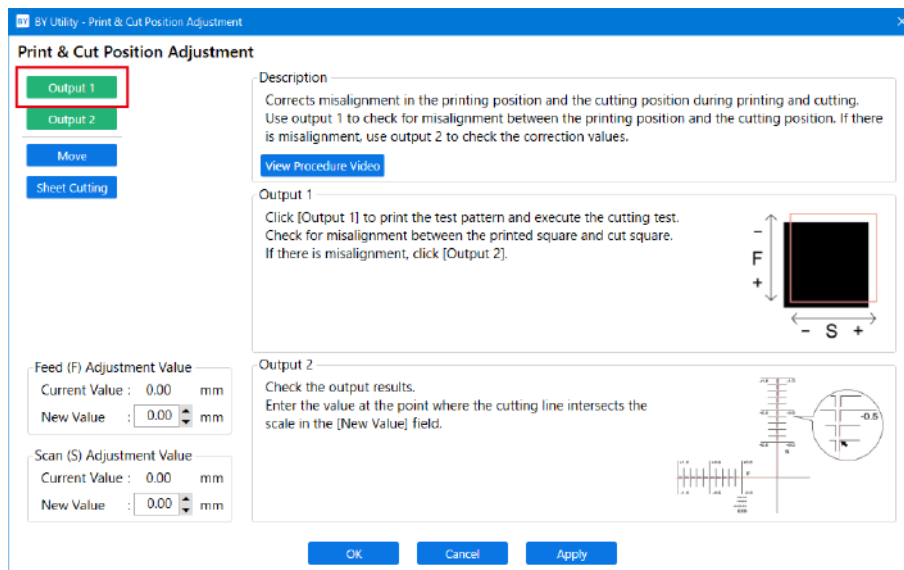

- **If the printing and cutting positions are misaligned**
To determine the correction values, carry out the steps for [Output 2]. Proceed to step 4.
- **If the printing and cutting positions are not misaligned**
This completes the print & cut position adjustment. Click [OK] to return to the original screen.

4. Click [Output 2].

The machine prints and cuts the test pattern.

5. Read the on-screen description and enter each value next to [New Value].

- **[Feed (F) Adjustment Value]:** -5.00 to 5.00 mm (-0.2 to 0.19 in.) (in units of 0.01 mm [0.0003 in.])
Enter the value at the point where the [Output 2] horizontal cutting line intersects the scale.
- **[Scan (S) Adjustment Value]:** -5.00 to 5.00 mm (-0.2 to 0.19 in.) (in units of 0.01 mm [0.0003 in.])
Enter the value at the point where the [Output 2] vertical cutting line intersects the scale.

6. Click [OK] to return to the original screen.

The values entered for [New Value] under [Feed (F) Adjustment Value] and [Scan (S) Adjustment Value] are applied to [Current Value].

Starting Print Output

⚠ CAUTION

Never insert your hand or fingers into the opening of the front cover.

The print head carriage moves at high speed inside the cover. Coming into contact with the moving carriage may cause injury.

Procedure

1. Prepare the print data.

2. Output the print data.

- **Outputting from Designer**

Refer to the "[Designer User's Manual](#)."

MEMO

Using Designer

Click the Designer icon in Roland DG Connect Hub.

If the Roland DG Connect login screen is displayed, enter your email address and password to log in.

- **Outputting from VersaWorks**

See the "[First Step Guide](#)."

3. Once output is complete, click  [Sheet Cutting].

4. Select the sheet cutting method, and then click [OK].

[Sheet Cutting]	This separates the media.
[Perforated Sheet Cutting]	The media is perforated without being separated.

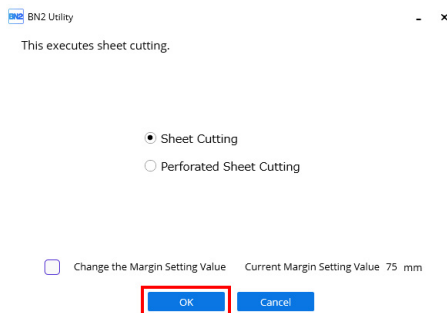

IMPORTANT

Output is not possible in these situations

- The machine does not run when the front, left, or right cover is open.
- Output does not start until the heater reaches the specified temperature.
When the ambient temperature is low, the heater is slow to warm up. Use the machine in an environment where the temperature is 20°C to 28°C (68°F to 82.4°F).
- With the setup of media complete, output is not performed when the sub power button's indicator is not lit in yellow or is not blinking in blue (indicating sleep mode).
- A warning beep goes off and output is not performed when an ink cartridge becomes empty. A message indicating that ink has run out is displayed in the Status field in the Utility window. Replace the empty ink cartridge with a new one, and then send the output data.

Points that must be observed

- Never open the front, left, or right cover while output is in progress. Doing so interrupts printing.
- When you are performing printing, clamp the edges of the media with the media clamps. Otherwise, the edges of the media may warp and catch on the print heads.
- During output, do not touch the media. Doing so may obstruct the media feed or cause the media to rub against the print heads, which may result in a paper jam or damage to the heads.
- Keep the loading lever raised when the machine is not in use.

When not using the machine, remove any media and store it in a suitable environment.

- If the machine is left with the media loaded, the media may be damaged, which may adversely affect printing. When not using the machine, remove any media and store it in a suitable environment.

RELATED LINKS

- [P. 88 Pausing and Resuming Output](#)
- [P. 89 Canceling Output](#)

How to Cut with Crop Marks

Preparations for Output with Crop Marks	120
Step 1: Performing a Nozzle Drop-out Test	120
Step 2: Normal Cleaning Method	122
Step 3: Adjusting Cutting	124
Step 4: Correcting the Misalignment of Printing and Cutting with Crop Marks	126
Starting Output with Crop Marks	128
Preparations for Cutting Output	130
Step 1: Setting Up Media with Crop Marks	130
Step 2: Switching Off the Print Heater and Dryer	131
Step 3: Preventing Pulling of the Media with Undue Force	132
Starting Cutting Output	133

Preparations for Output with Crop Marks

What Is Cutting with Crop Marks?

If you are removing the printed media and setting it up again in order to cut it (for example, if you are processing the media, such as laminating after printing, and then setting up this media again for cutting), you have to align the printing and cutting positions. By printing the data together with crop marks, you can make it possible to align the positions using the crop marks when you set up the media again to cut it. In this manual, this printing method is referred to as "cutting with crop marks."

"Crop marks" are marks used to align positions. They are also called "alignment marks."

Step 1: Performing a Nozzle Drop-out Test

Before you carry out actual printing, perform a printing test to ensure no dot drop-out or dot displacement occurs. If dot drop-out or dot displacement occurs, perform cleaning of the print heads (normal cleaning).

MEMO

When performing printing tests successively, you can select [Vertical Printing] or [Horizontal Printing] as the printing position for the second and later tests in comparison to the first test.

P. 194 Performing Printing Tests Arranged Horizontally

MEMO

Use the following link to view a reference video for this procedure. We recommend that you view this video to understand the overall flow of work.

<https://vimeo.com/1003475749/6df9f81a6c>

The BN2-20/20A is shown in this video, but the work and operation procedures are the same for this machine.

Procedure

1. On the home screen, click  [Cleaning].

2. Click [Output].

Printing of the test pattern starts.

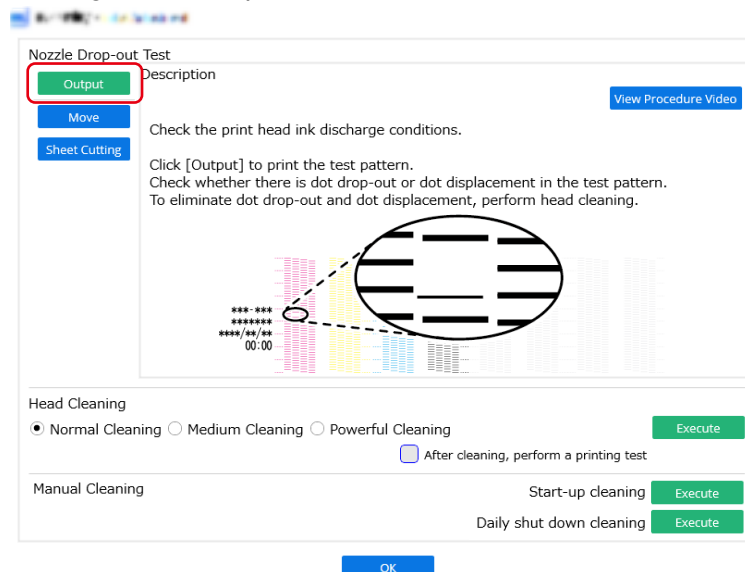

3. Check whether there is dot drop-out or dot displacement in the test pattern.

Missing blocks indicate dot drop-out. Collapsed or inclined blocks indicate dot displacement.

If dot drop-out or dot displacement is present, proceed to [Step 2: Normal Cleaning Method](#) and perform normal cleaning. Also, if dot drop-out is present in multiple locations within a row, see the procedure in [Handling Severe Dot Drop-out](#).

**MEMO**

Even if nozzle drop-out does not appear to be improved by cleaning, it may be possible to ignore the effect on products if drop-out occurs in just a few locations. Try printing. If you can judge that the product is not affected, use the printer without any further cleaning.

4. If you have opened the front cover, close it.

If no dot drop-out or dot displacement occurs, preparations for output are finished.

5. Click [Close] to return to the original window.

Step 2: Normal Cleaning Method

MEMO

If the media has already been set up, the [After cleaning, perform a printing test] menu appears. When this is turned on, a printing test is performed after cleaning.

Procedure

1. Select [Normal Cleaning] under [Head Cleaning], and then click [Execute].

The status is displayed as [Cleaning in progress.].

An estimate for the remaining cleaning time is displayed at the top of the Utility home screen.

On completion, you will return to the original window.

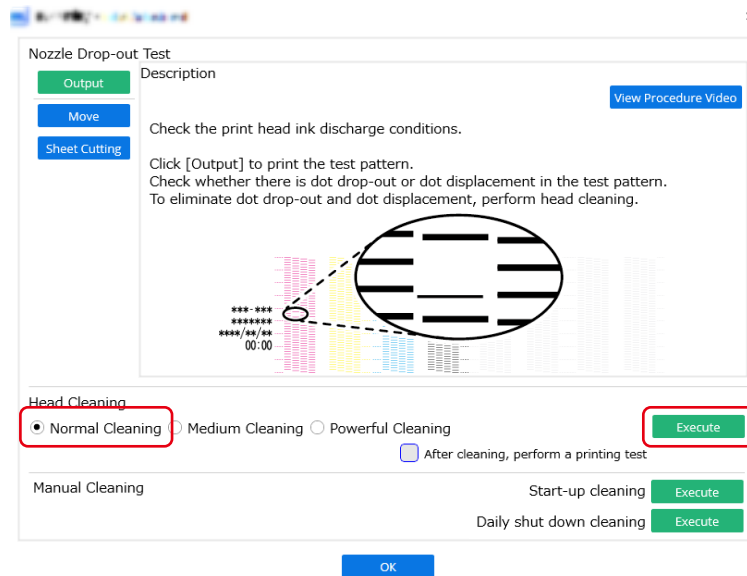

2. Click [Output].

Printing of the test pattern starts.

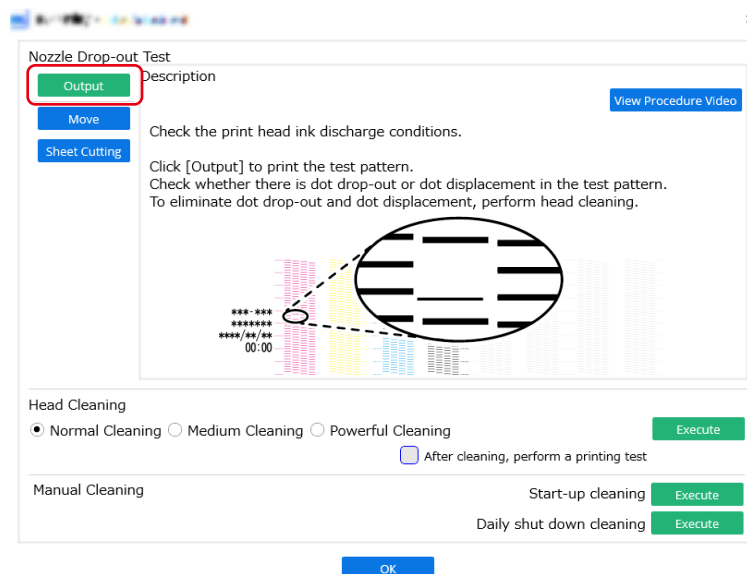

3. Check whether there is dot drop-out or dot displacement in the test pattern.

Missing blocks indicate dot drop-out. Collapsed or inclined blocks indicate dot displacement.

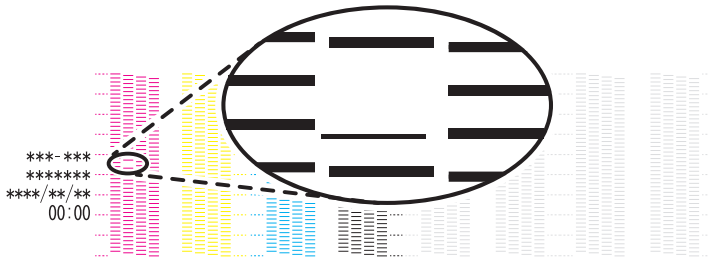

MEMO

- If the problem persists, try performing normal cleaning again.
- If problems such as dot drop-out and dot displacement persist even after you have performed normal cleaning several times, use a different cleaning method.

4. If you have opened the front cover, close it.

If no dot drop-out or dot displacement occurs, preparations for output are finished.

5. Click [Close] to return to the original window.

RELATED LINKS

- [P. 234 Medium Cleaning](#)
- [P. 236 Powerful Cleaning](#)

Step 3: Adjusting Cutting

For high-quality cutting, we recommend carrying out a cutting test to check the cutting quality for the media before you perform actual cutting. Adjust the blade force depending on the cutting quality.

MEMO

Use the following link to view a reference video for this procedure. We recommend that you view this video to understand the overall flow of work.

<https://vimeo.com/1003474895/208e3298e2>

The BN2-20/20A is shown in this video, but the work and operation procedures are the same for this machine.

Procedure

1. Close the front cover.
2. On the home screen, click  [Blade Adjustment].
3. Click [Output].

The test pattern is cut.

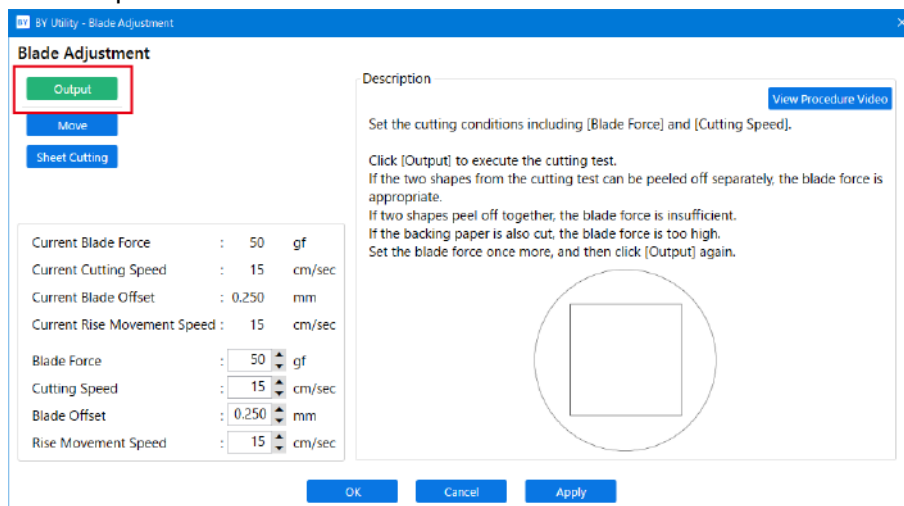

4. Peel off the cut shapes and change the [Blade Force] settings according to the cutting quality.

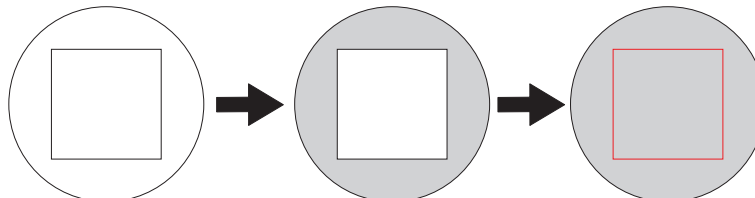

- **Two shapes are peeled off separately**
You do not need to perform the setting because the blade force is appropriate.
- **Two shapes are peeled off together**
Increase the blade force.
- **Backing paper is also cut**
Decrease the blade force.

5. Click [Apply].

The changed settings are saved.

6. Click [Apply] again.

The test pattern is cut.

7. Check whether the correction was successful.

In the [Apply] menu, you can also make settings for other cutting conditions in addition to the blade force.

8. Click [OK] to return to the original screen.

RELATED LINKS

- [P. 157 Accurately Adjusting the Cutting Settings](#)

Step 4: Correcting the Misalignment of Printing and Cutting with Crop Marks

Depending on the composition of the media, the positioning of printing and cutting may be misaligned even when you are using crop marks. Make corrections for misaligned printing and cutting for the media you are using.

MEMO

Use the following link to view a reference video for this procedure. We recommend that you view this video to understand the overall flow of work.

<https://vimeo.com/1003475517/ad4ccfe84e>

The BN2-20/20A is shown in this video, but the work and operation procedures are the same for this machine.

Procedure

1. Start Utility.
P. 15 Starting/Exiting Utility
2. Click .
3. Click [Execute] under [List of Media Settings]>[Crop Cut Position Adjustment [Media Not Removed]].

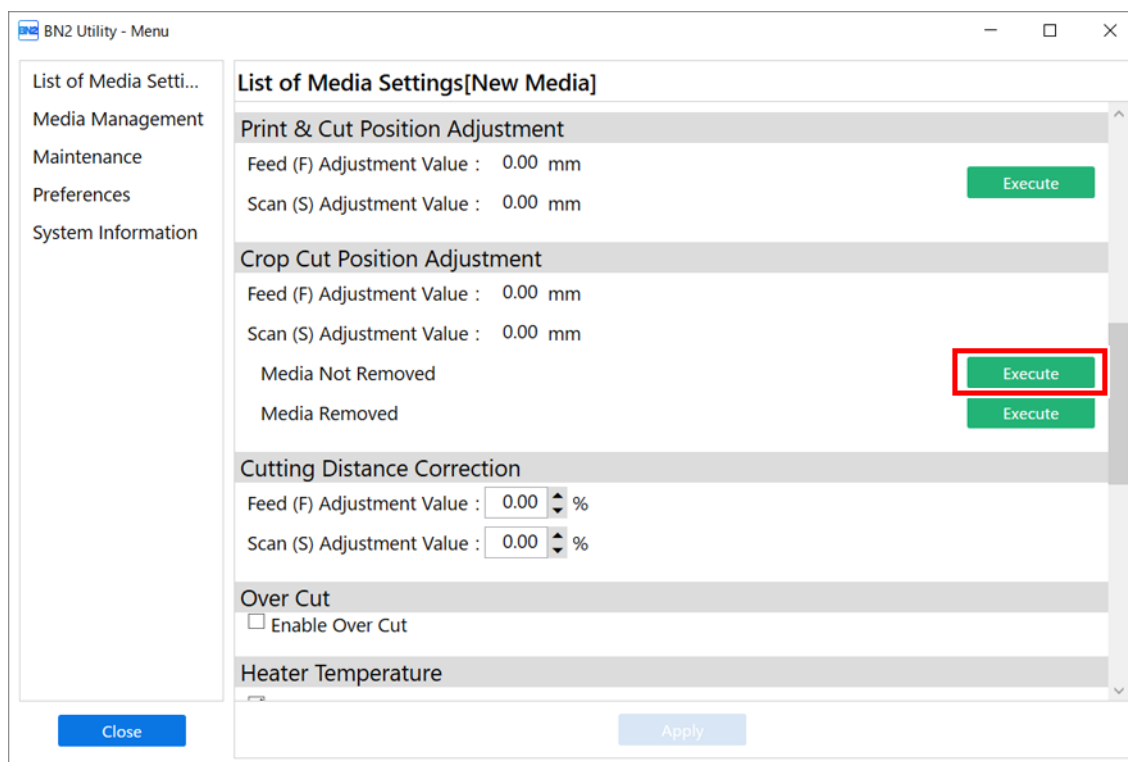

4. Click [Output 1].
The machine prints and cuts the test pattern. View the printing result, checking for misalignment in the printing position and cutting position.

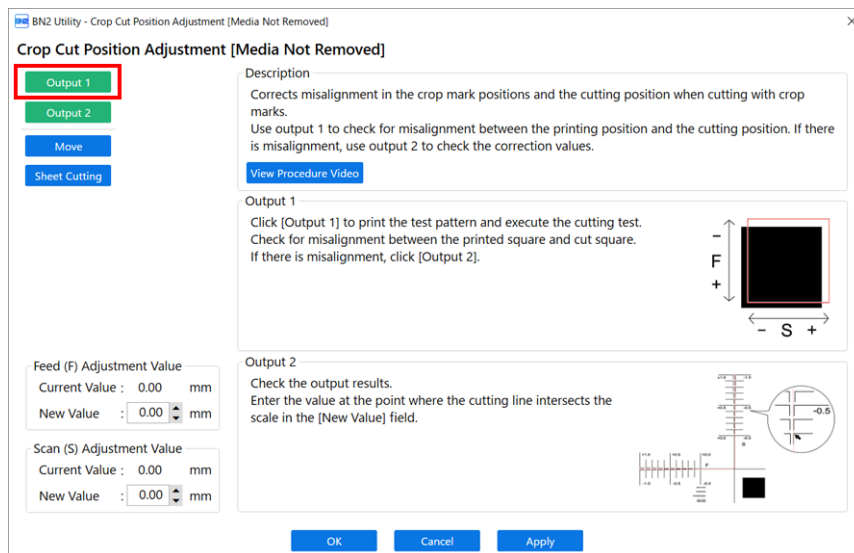

- **If the printing and cutting positions are misaligned**
To determine the correction values, carry out the steps for [Output 2]. Proceed to step 5.
- **If the printing and cutting positions are not misaligned**
This completes the [Crop Cut Position Adjustment]. Proceed to step 7.

5. Click [Output 1].

The machine prints and cuts the test pattern.

6. Read the on-screen description and enter each value next to [New Value].

- **[Feed (F) Adjustment Value]:** -5.00 to 5.00 mm (-0.2 to 0.19 in.) (in units of 0.01 mm [0.0003 in.])

Enter the value at the point where the [Output 2] horizontal cutting line intersects the scale.

- **[Scan (S) Adjustment Value]:** -5.00 to 5.00 mm (-0.2 to 0.19 in.) (in units of 0.01 mm [0.0003 in.])

Enter the value at the point where the [Output 2] vertical cutting line intersects the scale.

7. Click [OK] to return to the original screen.

The values entered for [New Value] under [Feed (F) Adjustment Value] and [Scan (S) Adjustment Value] are applied to [Current Value].

Starting Output with Crop Marks

⚠ CAUTION

Never insert your hand or fingers into the opening of the front cover.

The print head carriage moves at high speed inside the cover. Coming into contact with the moving carriage may cause injury.

IMPORTANT

Prepare just the printing data, do not include the cutting data. Use your software RIP to configure the settings to print with crop marks. For information on how to make the settings, refer to the documentation for the software RIP you are using.

Procedure

1. Prepare the print data.

2. Output the print data.

- **Outputting from Designer**

Refer to the "[Designer User's Manual](#)."

MEMO

Using Designer

Click the Designer icon in Roland DG Connect Hub.

If the Roland DG Connect login screen is displayed, enter your email address and password to log in.

- **Outputting from VersaWorks**

See the "[First Step Guide](#)."

3. Once output is complete, click  [Sheet Cutting].

MEMO

When performing sheet cutting, ensure that the margin at the trailing edge of the media is 70 mm (2.76 in.) or more.

4. Select [Sheet Cutting], and then click [OK].

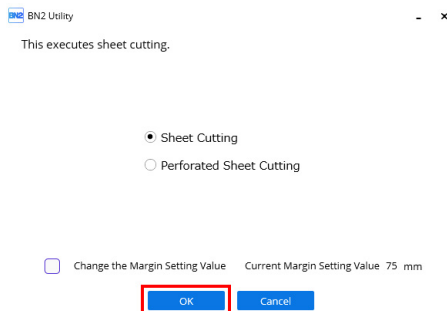

IMPORTANT

Output is not possible in these situations

- The machine does not run when the front, left, or right cover is open.
- Output does not start until the heater reaches the specified temperature.
When the ambient temperature is low, the heater is slow to warm up. Use the machine in an environment where the temperature is 20°C to 28°C (68°F to 82.4°F).
- With the setup of media complete, output is not performed when the sub power button's indicator is not lit in yellow or is not blinking in blue (indicating sleep mode).
- A warning beep goes off and output is not performed when an ink cartridge becomes empty. A message indicating that ink has run out is displayed in the Status field in the Utility window. Replace the empty ink cartridge with a new one, and then send the output data.

Points that must be observed

- Never open the front, left, or right cover while output is in progress. Doing so interrupts printing.
- When you are performing printing, clamp the edges of the media with the media clamps. Otherwise, the edges of the media may warp and catch on the print heads.
- During output, do not touch the media. Doing so may obstruct the media feed or cause the media to rub against the print heads, which may result in a paper jam or damage to the heads.
- Keep the loading lever raised when the machine is not in use.

When not using the machine, remove any media and store it in a suitable environment.

- If the machine is left with the media loaded, the media may be damaged, which may adversely affect printing. When not using the machine, remove any media and store it in a suitable environment.

Preparations for Cutting Output

Step 1: Setting Up Media with Crop Marks

Procedure

1. Load the media on which crop marks have been printed.

Place the front left and right crop marks so they are straight and aligned with the blade protector (A).

IMPORTANT

Ensure that the crop marks are not angled by more than 5 degrees. Crop marks cannot be read at higher angles.

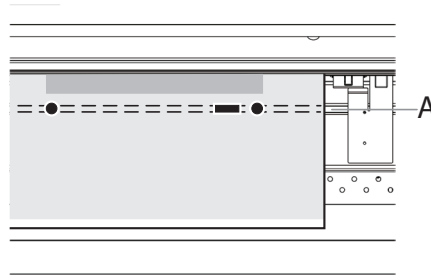

2. Finish the media setup and check that the home screen is displayed.

This completes the setup of the media with crop marks. Proceed to [Step 1: Switching Off the Print Heater and Dryer \(P. 102\)](#).

RELATED LINKS

- [P. 37 Setup of New Media](#)
- [P. 63 Setup of Registered Media](#)

Step 2: Switching Off the Print Heater and Dryer

Procedure

1. On the Utility home screen, click the following part.

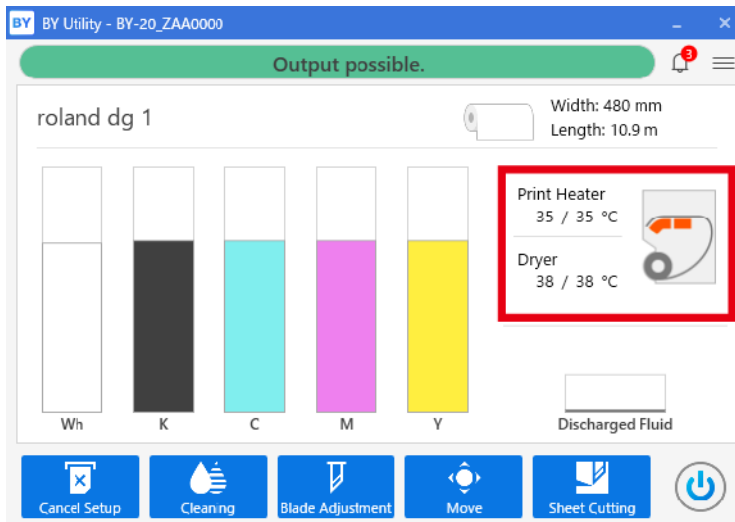

2. Clear the [Enable Print Heater] and [Enable Dryer] check boxes.

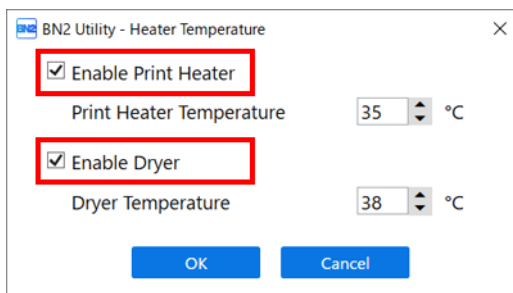

3. Click [OK] to confirm your entry.
The [Print Heater] and [Dryer] settings turn off.

Step 3: Preventing Pulling of the Media with Undue Force

Procedure

1. Click .
2. Select the [Preferences]>[Prefeeding at Output]>[Enable Prefeeding] check box.

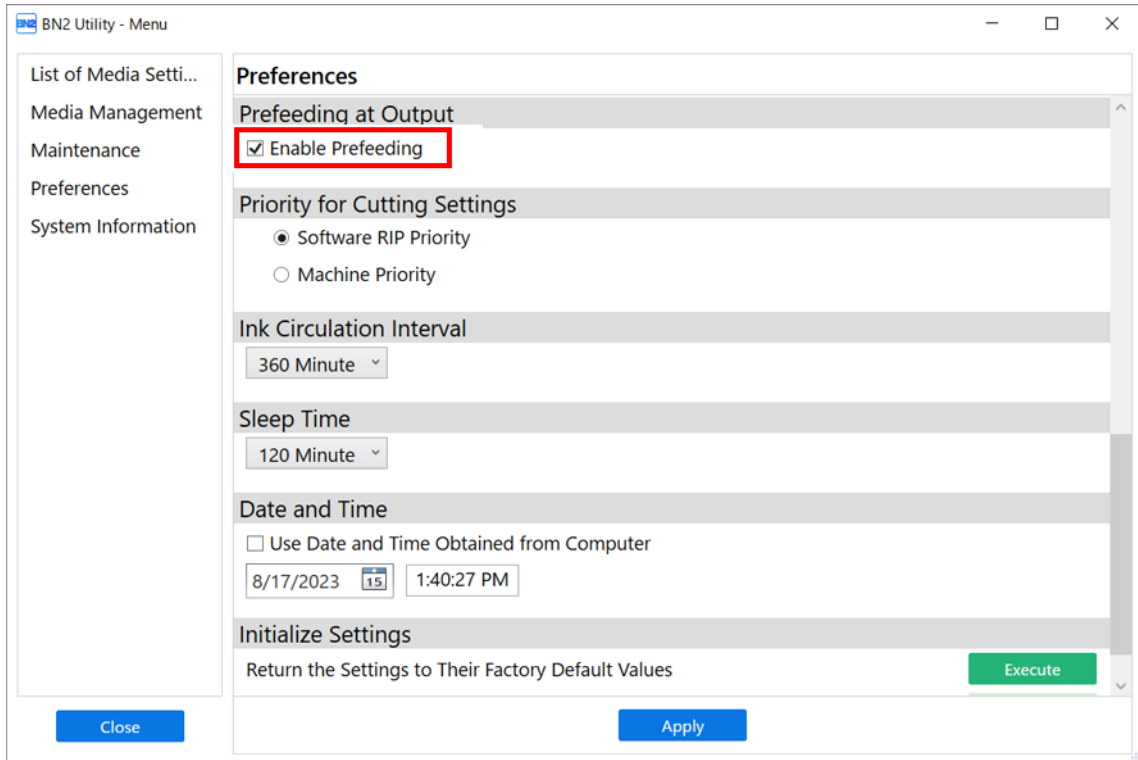

3. Click [Apply] to confirm your entry.
4. Click [Close] to return to the original screen.

Starting Cutting Output

⚠ CAUTION

Never insert your hand or fingers into the opening of the front cover.

The print head carriage moves at high speed inside the cover. Coming into contact with the moving carriage may cause injury.

IMPORTANT

Prepare just the cutting data, do not include the printing data.

Procedure

1. Prepare the print data.

2. Output the print data.

- **Outputting from Designer**

Refer to the "[Designer User's Manual](#)."

MEMO

Using Designer

Click the Designer icon in Roland DG Connect Hub.

If the Roland DG Connect login screen is displayed, enter your email address and password to log in.

- **Outputting from VersaWorks**

See the "[First Step Guide](#)."

3. Once output is complete, click [Cancel Setup].

IMPORTANT

When not using the machine, remove any media and store it in a suitable environment.

- If the machine is left with the media loaded, the media may be damaged, which may adversely affect printing. When not using the machine, remove any media and store it in a suitable environment.

RELATED LINKS

- [P. 88 Pausing and Resuming Output](#)
- [P. 89 Canceling Output](#)

Optimizing Quality and Efficiency

Optimizing the Output Quality

Using the Correction Functions.....	136
Automatically Making Required Adjustments	136
Manual Adjustment: Reducing Horizontal Bands (Feed Correction)	138
Manual Adjustment: Adjusting the Misalignment of the Ink Landing Position (Media Gap Adjustment).....	140
Configuring Settings to Match the Properties of the Media	142
Using Hard-to-Dry Media	142
Using Media That Wrinkles Easily/Does Not Move Smoothly	143
Using Sticky Media	144
Preventing Ink Discharge Issues	145
Preventing Soiling of the Media, Dot Drop-out, and Dot Displacement.....	145
Adjusting the Ink-drying Method	147
What Is the Media Heating System?	147
Setting the Print Heater Temperature	149
Setting the Dryer Temperature.....	151
Hints and Tips for Temperature Control	153
Setting the Temperature during Standby.....	154
Drying the Trailing Edge of the Printing Area on the Dryer	155
Accurately Adjusting the Cutting Settings.....	157
Fine-tuning the Cutting Conditions.....	157
Adjusting the Amount of Blade Extension	159
Performing Distance Correction during Cutting	160
Cutting to Make It Possible to Cut Corners Attractively (Over Cut)	161
Accurately Adjusting the Settings for Printing and Cutting	163
Correcting the Misalignment of Printing and Cutting	163
Accurately Adjusting the Settings for Cutting with Crop Marks	167
Correcting the Misalignment of Printing and Cutting with Crop Marks (Crop Cut Position Adjustment [Media Not Removed])	167
Correcting the Misalignment of Printing and Cutting with Crop Marks (Sepa- rate Test for Printing and Cutting with Crop Marks [Media Removed])	172
Correcting the Reading Sensor (Multi Sensor Adjustment).....	179

Using the Correction Functions

To optimize the output quality, it is effective to use some correction functions.

The printing area must be 300 mm (11.82 in.) or more with simple correction (automatic) and 340 mm (13.39 in.) or more with detailed correction (manual).

Automatically Making Required Adjustments

To optimize the output quality, corrections must match the media and printing conditions.

Depending on the printing conditions, the ink landing position may be misaligned and the movement distance may change subtly during media feeding. Automatically correct these issues to match the media.

First, print a test pattern. Then read this pattern with the multi sensor and automatically enter the correction values.

Executing automatic correction prints a test pattern, reads this pattern, and enters the correction values for the following operations.

- Multi sensor adjustment (adjusting to the optimal condition the sensor used in correction)
- Media gap adjustment (correcting the ink landing position)
- Feed correction (to reduce horizontal bands)

Procedure

1. Set up the media.
2. Close the front cover.
3. Click .
4. Click [List of Media Settings]>[Batch Automatic Correction].

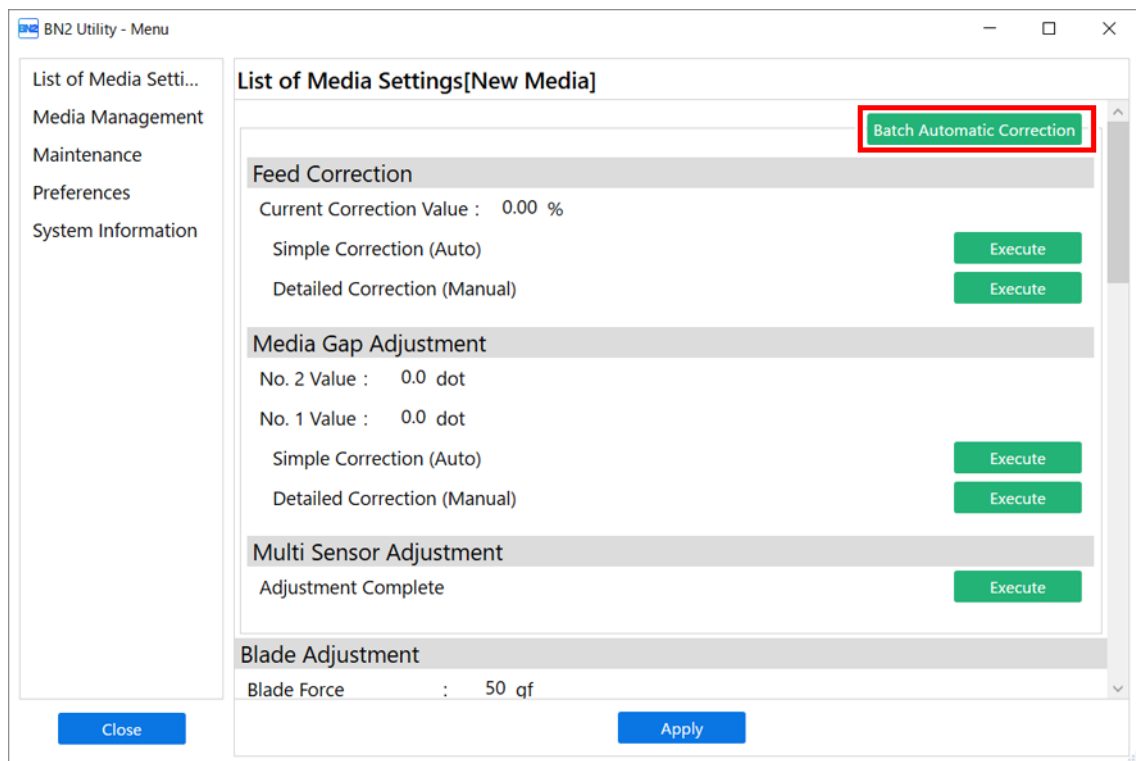

5. Click [OK].

Test patterns are printed and correction values are entered for the following operations.

- Multi Sensor Adjustment
- Feed Correction
- Media Gap Adjustment

6. When a completion screen appears, click [OK].

If the message [Adjustment failed.] appears, perform manual correction.

RELATED LINKS

- [P. 138 Manual Adjustment: Reducing Horizontal Bands \(Feed Correction\)](#)
- [P. 140 Manual Adjustment: Adjusting the Misalignment of the Ink Landing Position \(Media Gap Adjustment\)](#)

Manual Adjustment: Reducing Horizontal Bands (Feed Correction)

Perform corrections to make the band-shaped "stripes" on the printed surface less noticeable.

The band-shaped "stripes" are called "horizontal bands" or "banding." Horizontal bands are caused by the subtle changes in the movement distance that occur when feeding the media depending on the media's thickness and the temperature of the dryer. We recommend that you make corrections to match the media you are using and the set temperature of the dryer.

First, print a test pattern, and then determine and enter the correction value. After entering the correction value, print a test pattern again and check the correction results. Repeat the process of printing a test pattern and entering a correction value several times to find the optimal correction value.

Procedure



1. Set up the media.
2. Close the front cover.
3. Click .
4. Click [Execute] under [List of Media Settings]>[Feed Correction]>[Detailed Feed Correction (Manual)].
5. Click [Output].
Printing of the test pattern starts.

6. Check the printed test pattern, and then enter the correction value for [New Value].

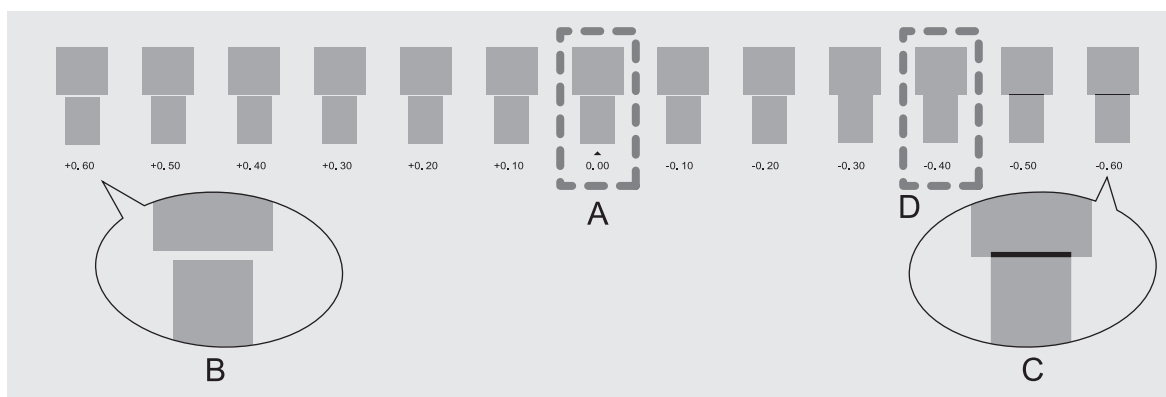
The current correction value (A) is that of the figure indicated by "▲." Select the value to make the gap (B) and overlap (C) between the upper/lower squares smallest. In the case of the following figure, select "-0.40" (D). When you cannot choose between two sequential numbers, specify a value that is between them.



MEMO

- If the test pattern is difficult to see, click  or  next to [Move] to move the media to a position where it is easier to see.
- If you want to hold the media to check the test pattern, you can also use the sheet cutting function to separate the media.

7. Click [Apply].
The entered correction value is saved.

- 8.** To check the adjustment results, click [Output] again.
The test pattern is printed again.
- 9.** Check the test pattern to see whether the correction was successful.
Check that the gap and overlap are the smallest for the figure indicated by "▲" (that is, the current correction value). If the gap and overlap are smaller for another figure, set the correction value again.
- 10.** When you have successfully performed the adjustment, click [OK] to return to the original screen.

Manual Adjustment: Adjusting the Misalignment of the Ink Landing Position (Media Gap Adjustment)

This adjusts the landing position of the ink discharged from the print heads. The landing position varies according to the print head height and the thickness of the media, so we recommend that you make corrections to match the media you are using.

First, print a test pattern, and then determine and enter the correction value. After entering the correction value, print a test pattern again and check the correction results.

This adjustment must be performed in the following cases.

- When using this machine for the first time
- When changing the media to use

MEMO

Use the following link to view a reference video for this procedure. We recommend that you view this video to understand the overall flow of work.

<https://vimeo.com/1003476100/c1e3b0b7fb>

The BN2-20/20A is shown in this video, but the work and operation procedures are the same for this machine.



Procedure

1. Set up the media.
2. Close the front cover.
3. Click .
4. Click [Execute] under [List of Media Settings]>[Media Gap Adjustment]>[Detailed Media Gap Adjustment (Manual)].
5. Click [Execute].
Printing of the test pattern starts.
6. Check the printed test pattern, and then enter the No. 1: H1 and H2 and the No. 2: H1 and H2 correction values.

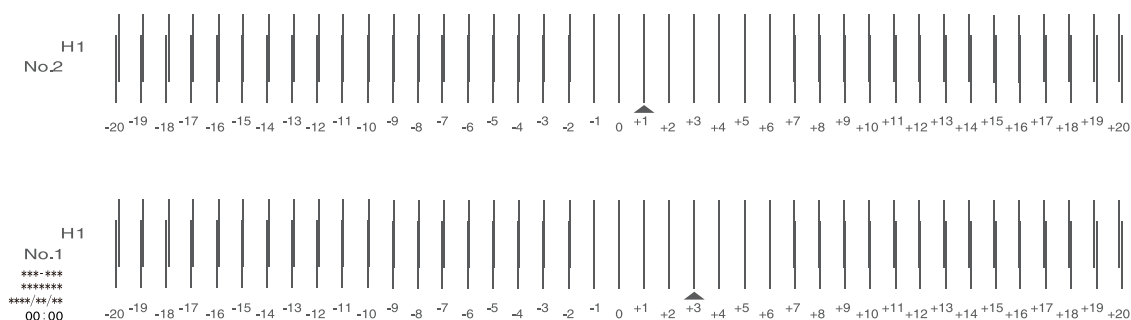
Select the value that gives the least misalignment between the two lines. In the case of the following figure, select "+5" for H1 and "+4" for H2. When you cannot choose between two sequential numbers, select a value that is between them (you can set correction values in units of "0.5").



MEMO

- If the test pattern is difficult to see, click  or  next to [Move] to move the media to a position where it is easier to see.
- If you want to hold the media to check the test pattern, you can also use the sheet cutting function to separate the media.

7. Click [Apply].

The entered correction values are saved.

8. To check the adjustment results, click [Output] again.

The test pattern is printed again.

9. Check the test pattern to see whether the correction was successful.

For all the correction values, check that the misalignment is minimized for the two vertical lines indicated by "▲" (that is, the current correction value). If the misalignment is smaller for another set of vertical lines, set the correction value again.

10. When you have successfully performed the adjustment, click [OK] to return to the original screen.

Configuring Settings to Match the Properties of the Media

Using Hard-to-Dry Media

This setting is used to extend the drying time when the ink dries poorly even if the dryer is used.

Procedure

1. Set up the media.
2. Click .
3. Enter the drying time in [List of Media Settings]>[Drying Time Per Scan].
Larger values cause the media to move more slowly, extending the drying time accordingly.

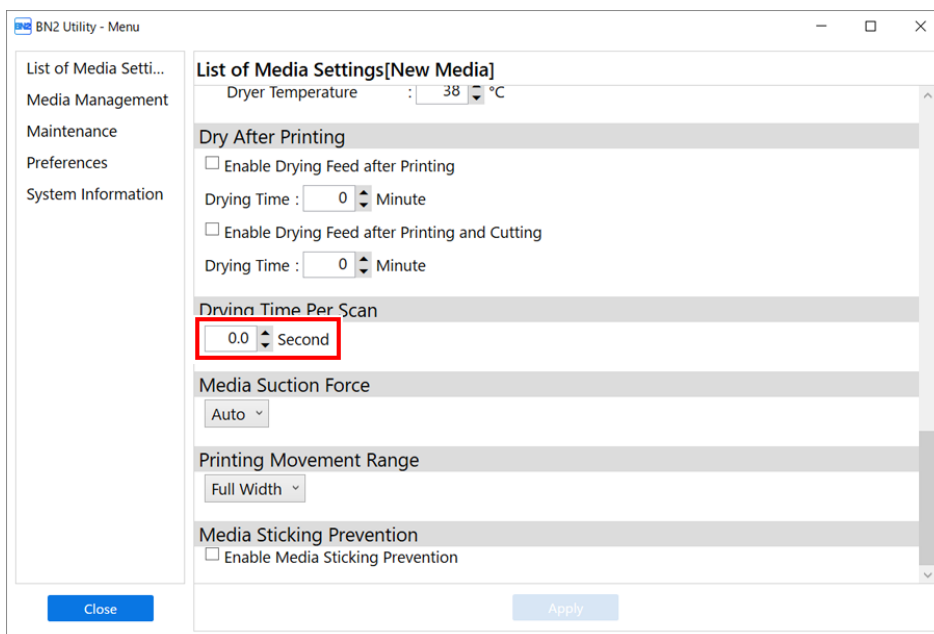

4. Click [Apply] to confirm your entry.
5. Click [Close] to return to the original screen.

MEMO

- Default setting: 0.0 seconds
- Depending on the software RIP you are using, you can also make this setting in the software RIP. When you have made the setting in the software RIP, the printer's setting is ignored.

Using Media That Wrinkles Easily/Does Not Move Smoothly

The platen uses suction to grip the media and keep it stable. The suction force can be adjusted corresponding to the nature and condition of the media.

Procedure

1. Set up the media.
2. Click .
3. From [List of Media Settings]>[Media Suction Force], select the setting.

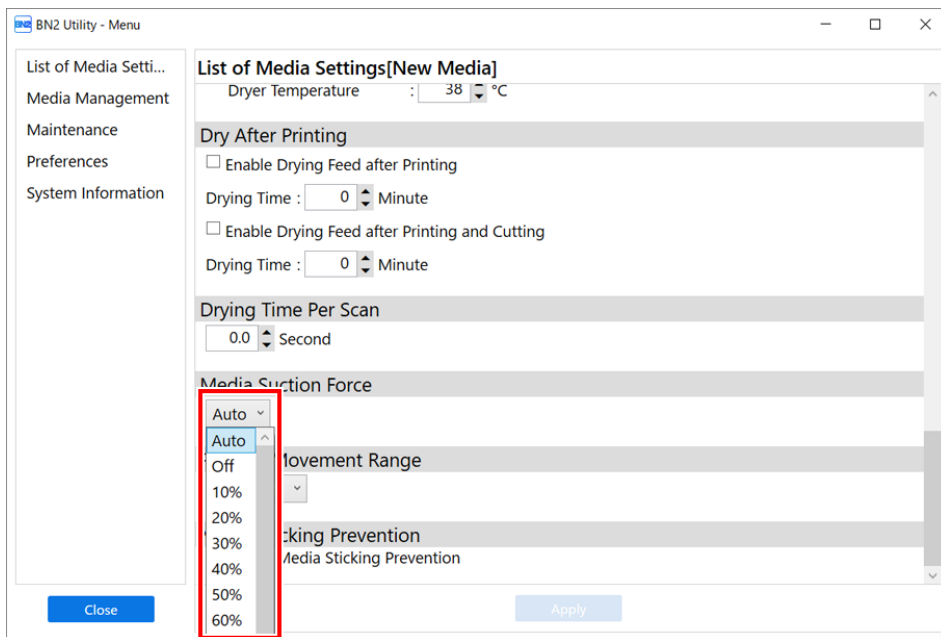

Auto	The suction force is automatically adjusted to the optimal level for the width of the loaded media.
Off	Select this setting when you do not want to suction the media.
10 to 100%	When the media is flimsy and cannot move smoothly, decreasing this value (reducing the suction force) may correct the problem.

4. Click [Apply] to confirm your entry.
5. Click [Close] to return to the original screen.

MEMO

- Default setting: [Auto]
- Depending on the software RIP you are using, you can also make this setting in the software RIP. When you have made the setting in the software RIP, the machine's setting is ignored.

Using Sticky Media

This setting is used to peel off the media before starting printing when using media that sticks easily to the platen. This setting is effective to prevent media jams.

Note, however, that peeling off the media may cause unstable media feed. Leave this menu item off unless you specifically need to change it.

Procedure

1. Set up the media.
2. Click .
3. Select the [Enable Media Sticking Prevention] check box under [List of Media Settings]>[Media Sticking Prevention].

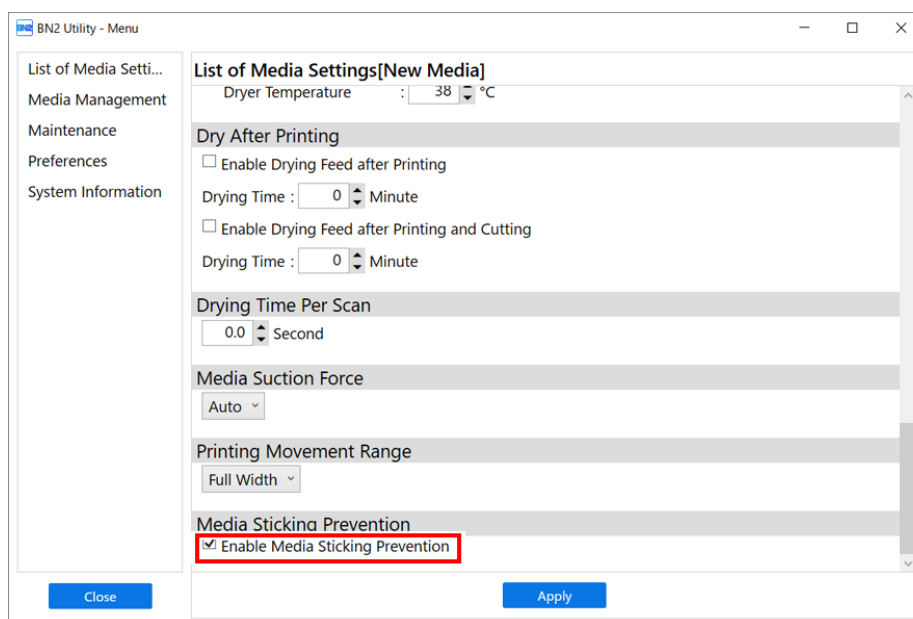

4. Click [Apply] to confirm your entry.
5. Click [Close] to return to the original screen.

MEMO

- Default setting: Off

Preventing Ink Discharge Issues

Preventing Soiling of the Media, Dot Drop-out, and Dot Displacement

Removing the ink buildup on the print head surface before or during printing prevents soiling of the media, dot drop-out, and dot displacement.

In the following cases, ink tends to collect on the surface of the print heads.

- When you use media prone to static electricity buildup.
- When the ambient temperature is low.

Procedure

1. Click .
2. Click [Preferences].
3. Click a setting under [Cleaning during Printing] to select it.

If you select [Periodically (Job Priority)] or [Periodically (Time Priority)], the cleaning time is set automatically.

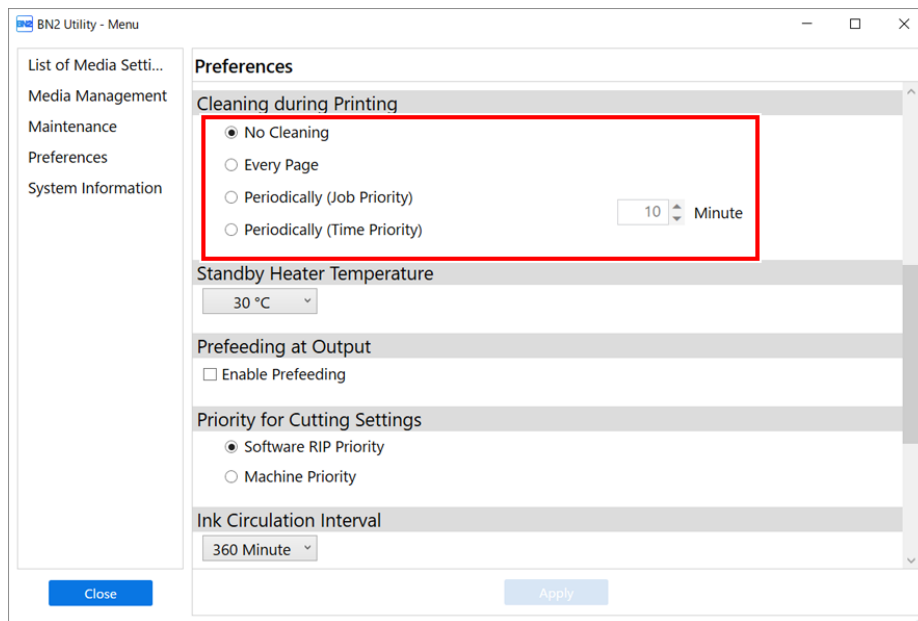

[No Cleaning]	Automatic cleaning is not performed.
[Every Page]	Automatic cleaning is performed each time prior to the start of printing.
[Periodically (Job Priority)]	Automatic cleaning is performed when the cumulative printing time reaches the value you set here. However, if this time is reached during printing, automatic cleaning is performed before the next printing operation starts. Because printing is not paused, uneven color issues due to paused operation do not occur.
[Periodically (Time Priority)]	Automatic cleaning is performed when the cumulative printing time reaches the value you set here. When this time is reached during printing, printing pauses and so colors may be uneven.

4. Click [Apply] to confirm your entry.
5. Click [Close] to return to the original screen.

MEMO

- Default setting: [No Cleaning]
- Settings other than [No Cleaning] result in longer printing times.

Adjusting the Ink-drying Method

What Is the Media Heating System?

This machine is equipped with a media heating system that warms the media. You use this mainly to improve ink adhesion and dry the ink. You can adjust the temperature settings to match the type of media and the printing speed.

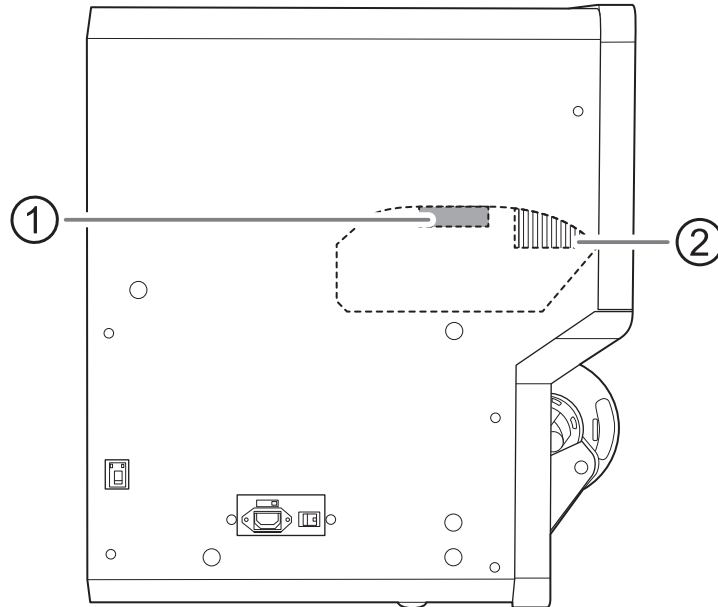

①	Print heater	This heater is used mainly to improve ink adhesion.
②	Dryer	This is used to speed up the drying of the ink.

⚠ WARNING

High Temperature

The platen and dryer become hot. Exercise caution to avoid burns.

⚠ WARNING

Remove any loaded media or switch off the sub power when printing is not being performed.

The continued application of heat at a single location may cause the release of toxic gases from the media or pose a fire hazard.

⚠ WARNING

Never use media that cannot withstand heat.

Doing so may degrade the media, or may result in fire or the release of toxic gases.

⚠ WARNING

Never use the platen or dryer for any purpose for which they are not intended, such as to dry clothing.

Doing so may cause overheating, resulting in fire or accident.

IMPORTANT

Use the machine in an environment with an ambient temperature of 20 to 28°C (68 to 82.4°F).

If the machine is used at an ambient temperature lower than 20°C (68°F), then depending on the type or width of the media, wrinkling or temperature-caused unevenness may occur. If this happens, try lowering the temperature of the media heating system by about 2°C. To obtain stable printing results, however, use the machine in an environment with an ambient temperature of 20°C to 28°C (68°F to 82.4°F).

Setting the Print Heater Temperature

Setting the temperature of the print heater appropriately improves ink adhesion and inhibits smudging. An applicable application is changing the set temperature of registered media.

- With the default settings, the temperature rises to the standby heater temperature when the power turns on. On completion of media setup, the temperature rises to the set value.
- Depending on the usage environment, the temperature of the dryer may become higher than the set temperature, but this does not represent a problem.
- Temperature settings are not possible when [Enable Print Heater] accessed from [List of Media Settings]>[Heater Temperature] is off.

Procedure

1. Set up the media.
2. Click the following location on the home screen.

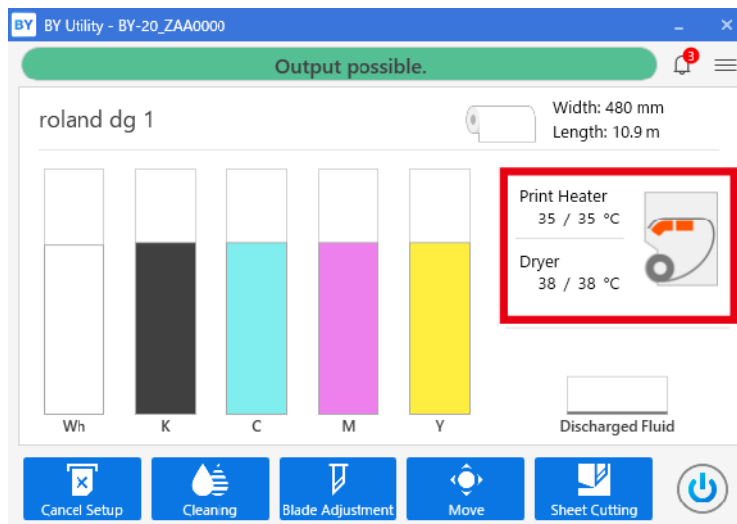

The [Heater Temperature] window appears.

3. Check that the [Enable Print Heater] check box is selected.

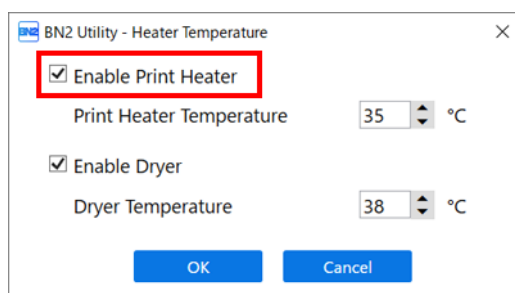

4. Set the [Print Heater Temperature] value.

If the ink forms lumps or smudges, raise the temperature. Note, however, that a temperature that is too high may degrade the media or cause it to wrinkle.

5. Click [OK] to confirm your entry.

MEMO

- Default setting: 35°C (95°F)
- You can also make this setting in the software RIP. When you have made the setting in the software RIP, the software RIP's setting is used.

RELATED LINKS

- [P. 51 Configure settings to match the media.](#)

Setting the Dryer Temperature

Setting the temperature of the dryer appropriately makes the ink dry fast. An applicable application is changing the set temperature of registered media.

- With the default settings, the temperature rises to the standby heater temperature when the power turns on. On completion of media setup, the temperature rises to the set value.
- Depending on the usage environment, the temperature of the dryer may become higher than the set temperature, but this does not represent a problem.
- Temperature settings are not possible when [Enable Dryer] accessed from [List of Media Settings]>[Heater Temperature] is off.

Procedure

1. Set up the media.
2. Click the following location on the home screen.

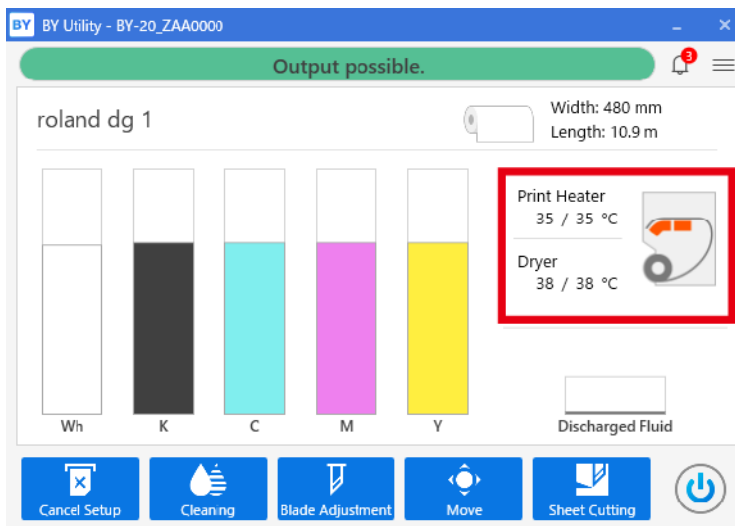

The [Heater Temperature] window appears.

3. Check that the [Enable Dryer] check box is selected.

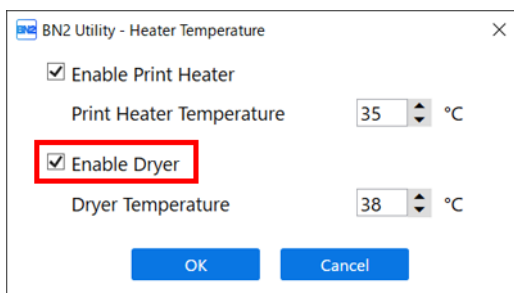

4. Set the [Dryer Temperature] value.

When ink drying is poor, set the temperature to a higher value. Note, however, that a temperature that is too high may degrade the media or cause it to wrinkle.

5. Click [OK] to confirm your entry.

MEMO

- Default setting: 38°C (100.4°F)
- You can also make this setting in the software RIP. When you have made the setting in the software RIP, the software RIP's setting is used.

RELATED LINKS

- [P. 51 Configure settings to match the media.](#)

Hints and Tips for Temperature Control

The optimal temperature for the media heating system varies according to such factors as the type of media and the settings of the software RIP.

Relationship between the quality settings of the software RIP and temperature

If smudging or poor drying occur even after raising the temperature, try setting the printing quality of the software RIP to higher image quality. Conversely, if you want to use a faster print quality, raise the temperature.

Amount of ink

When you change the amount of ink using the settings for your software RIP, adjusting this may yield better results. If problems such as smudging persist even after raising the temperature, try reducing the amount of ink.

Other points to remember

When recommended settings for temperature, printing quality, and other values are given for your media, use the suggested settings.

Setting the Temperature during Standby

The machine is on standby when the following two conditions are met.

- The main power and sub power are on.
- The media setup is incomplete.

Procedure

1. Click .
2. With [Preferences]>[Standby Heater Temperature], set the heater temperature during standby. Select [Off] to switch the media heating system off during standby.

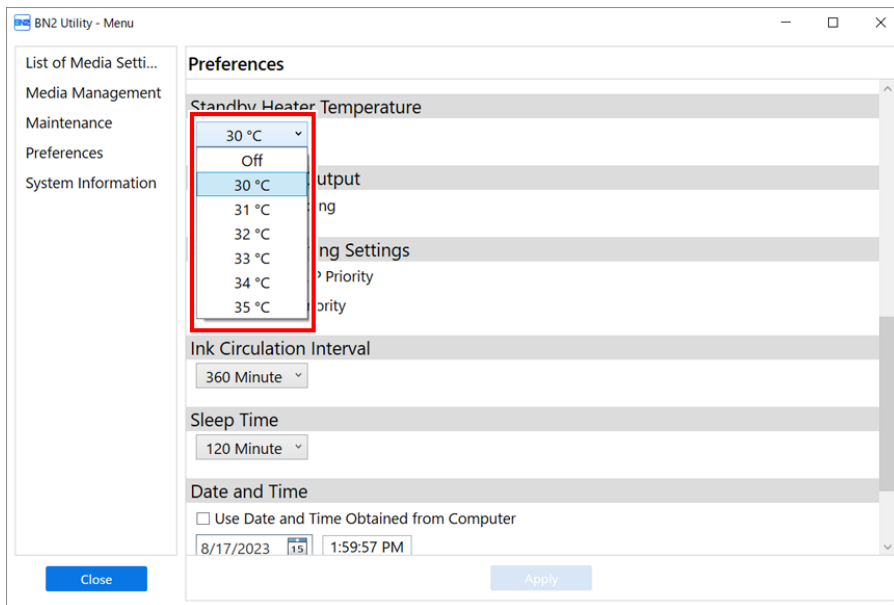

3. Click [Apply] to confirm your entry.
4. Click [Close] to return to the original screen.

MEMO

- Default setting: 30 °C

Drying the Trailing Edge of the Printing Area on the Dryer

To dry the ink thoroughly, configure the settings so that the media is fed until the trailing edge of the printed area is put on the dryer after the printing is finished.

Procedure

1. Set up the media.
2. Click .
3. Select the [Enable Drying Feed after Printing] or [Enable Drying Feed after Printing and Cutting] check box under [List of Media Settings]>[Dry After Printing].

MEMO

With one of these check boxes selected, media is fed until the trailing edge of the printing area is on top of the dryer.

With these check boxes cleared, the machine stops feeding the media when printing finishes. This means that the trailing edge of the printing area is not fed to the dryer unless you continue with a subsequent printing operation.

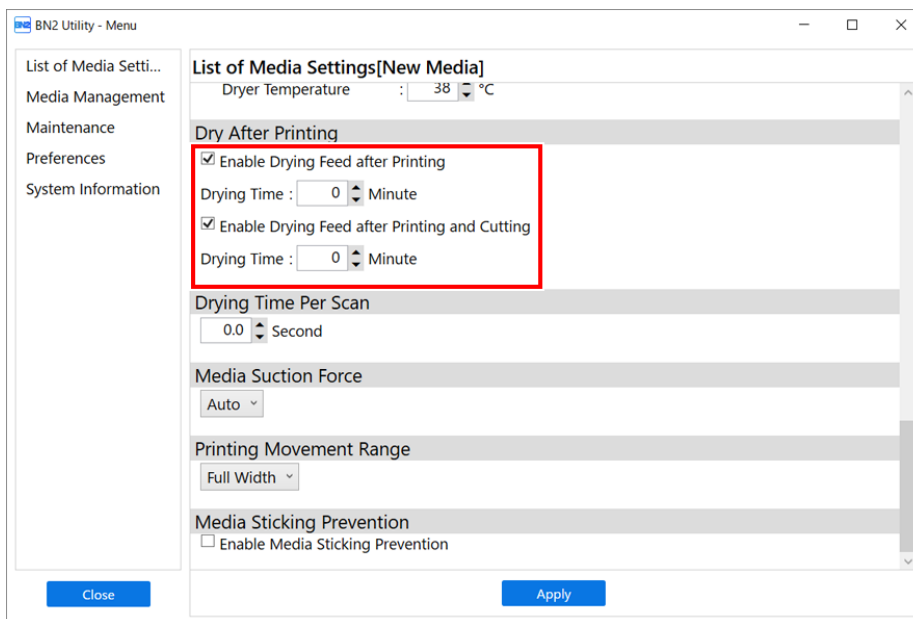

[Enable Drying Feed after Printing]	This setting applies to output data designed only for printing. This setting is ignored for output data designed for printing and cutting.
[Enable Drying Feed after Printing and Cutting]	This setting applies to output data designed for printing and cutting. This setting is ignored for output data designed only for printing.

4. Enter the drying time under [Enable Drying Feed after Printing] or [Enable Drying Feed after Printing and Cutting].

MEMO

Drying Time

- The next operation is not started until the set time elapses.
- Click [Skip] during drying to finish the drying time and start the next operation.
- When the drying time has been set in the software RIP, priority is given to the software RIP's setting.

- In the following situations, the machine waits for the set time at the print-end position before starting the next operation.
 - When [Drying Time] is set to a value other than [0 min]
 - When the [Enable Drying Feed after Printing] or [Enable Drying Feed after Printing and Cutting] check box under [Dry After Printing] is cleared.

5. Click [Apply] to confirm your entry.

6. Click [Close] to return to the original screen.

MEMO

Default setting:

- [Enable Drying Feed after Printing]: Off
[Drying Time]: [0 min]
- [Enable Drying Feed after Printing and Cutting]: On
[Drying Time]: [0 min]

Accurately Adjusting the Cutting Settings

Fine-tuning the Cutting Conditions

You can accurately set items such as the blade force, movement speed, and blade offset to match the nature of the media and the shape to cut.

First, perform a cutting test, and then determine and enter the setting values. After entering the setting values, perform a cutting test again and check the results. Repeat the process of performing a cutting test and making the settings several times to find the optimal setting values.

MEMO

Use the following link to view a reference video for this procedure. We recommend that you view this video to understand the overall flow of work.

<https://vimeo.com/1003474895/208e3298e2>

The BN2-20/20A is shown in this video, but the work and operation procedures are the same for this machine.

Procedure

1. Set up the media.
2. Close the front cover.
3. On the home screen, click  [Blade Adjustment].
4. Click [Output].

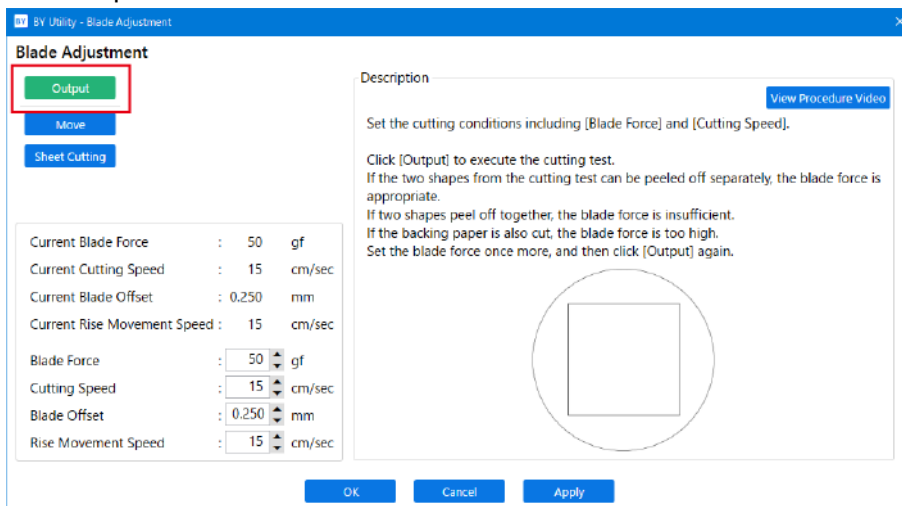

The test pattern is cut.

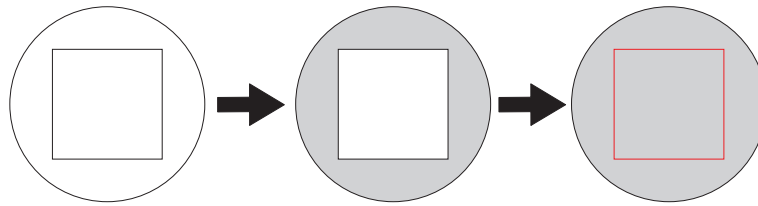

5. Check the results of the cutting test.

If the results are difficult to see, use the sheet cutting function to separate the media, and then hold it to check the results.



Check item	Result	Setting item	Adjustment
Check the shape.	The cut shape is distorted.	[Cutting Speed]	Reduce
Peel off the circle.	The square also peels off.	[Blade Force]	Increase
	Some uncut areas remain.	[Cutting Speed]	Reduce
Peel off the square.	The blade leaves faint traces on the backing paper.	[Blade Force]	No change
	The blade trace is indistinct.		Increase
	The blade trace is too deep and cuts into the backing paper.		Reduce
Check the shape of the square you have peeled off.	 The corners are not rounded and do not have "horns."	[Blade Offset]	No change
	 The corners are rounded.		Increase
	 The corners have "horns."		Reduce

6. Change the settings.

Cutting condition	Setting details	Default settings
[Blade Force]	Set the force (pressure) of the blade.	50 gf
[Cutting Speed]	Set the speed of cutting.	15 cm/s (5.91 in./s)
[Blade Offset]	Set the blade offset. Enter the listed offset value for the blade. The offset value for the included blade is 0.250 mm (9.8 mil).	0.250 mm (0.010 in.)
[Rise Movement Speed]	Set the blade's up speed during cutting (the speed at which the blade travels when it moves to the next cutting line after cutting one cutting line). If the media comes loose during no-load feed and the blade damages the surface of the media, reduce the speed.	15 cm/s (5.91 in./s)

7. Click [OK] to return to the original screen.

The changed settings are applied to their current values.

Adjusting the Amount of Blade Extension

When you want to perform accurate and fine adjustment of the cutting-in amount, such as when cutting media with thin backing paper, you can obtain good results by adjusting the amount of blade extension (③). Turn the cap portion of the blade holder to adjust the amount of blade extension. Each indicator tick corresponds to 0.1 millimeters, and adjustment for 0.5 millimeters can be made by rotating the cap one full turn.

Note that making the amount of blade extension too small may cause the tip of the blade holder cap to touch the printed surface, soiling and damaging it. It is important to be especially careful about this when you are using media that has poor ink-adhesion properties.

The amount of blade extension (③) is 0 mm (0 in.) (①) at minimum and 2.5 mm (0.09 in.) (②) at maximum.

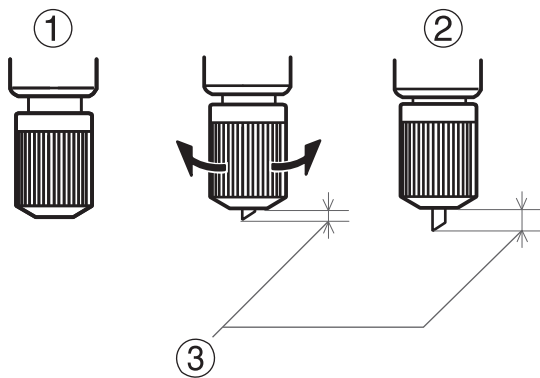

Guideline for the Amount of Blade Extension

Set the amount of blade extension (①) to an amount that is the sum of the thickness of the media portion (②) and half (④) the thickness of the backing paper (③).

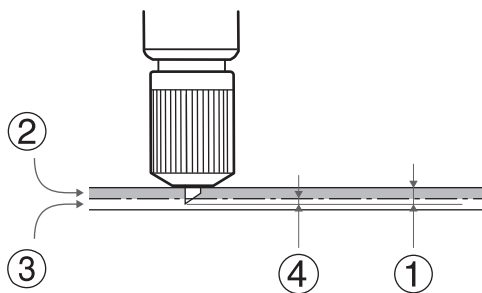

Performing Distance Correction during Cutting

This correction is performed when you want to accurately align the lengths of cut lines when cutting. The value set here is applied during cutting only and printing and cutting.

The movement distance of the media changes slightly depending on the media's thickness. This means that the length of a line when cut may differ from the length setting in the data.

Procedure

1. Set up the media.
2. Click .
3. Change the [List of Media Settings]>[Cutting Distance Correction] correction values.

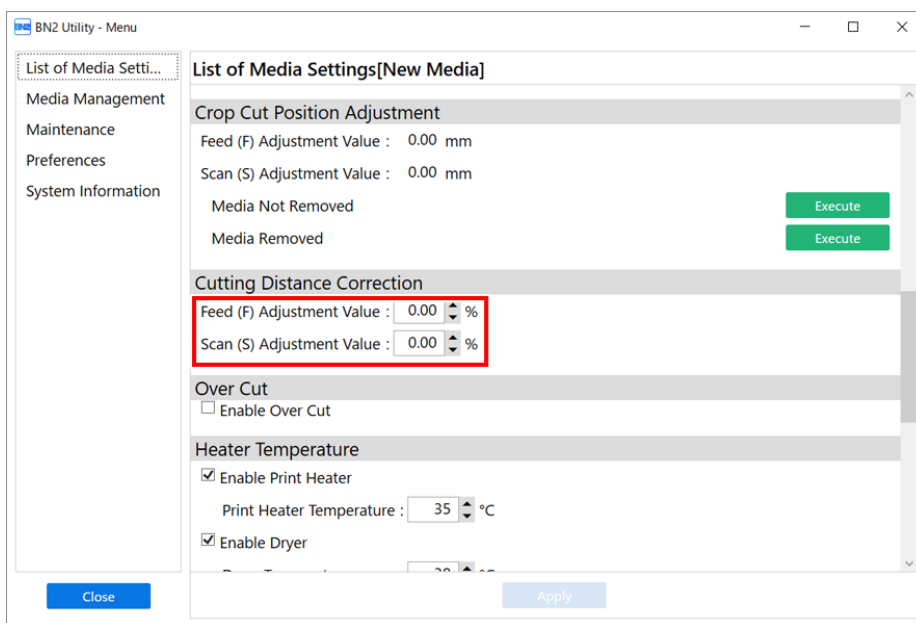

Setting item	Setting details	Default settings
[Feed (F) Adjustment Value]	(correction value of media feed direction)	0.00%
[Scan (S) Adjustment Value]	Correction value of the print-head carriage movement direction	0.00%

4. Click [Apply] to confirm your entry.
5. Click [Close] to return to the original screen.

Cutting to Make It Possible to Cut Corners Attractively (Over Cut)

Cutting the corners of the border of the cutting line slightly longer makes it possible to cut the corners attractively.

This is effective when using laminated or thick media, or non-resilient media. It also has the effect of making stickers easier to peel off.

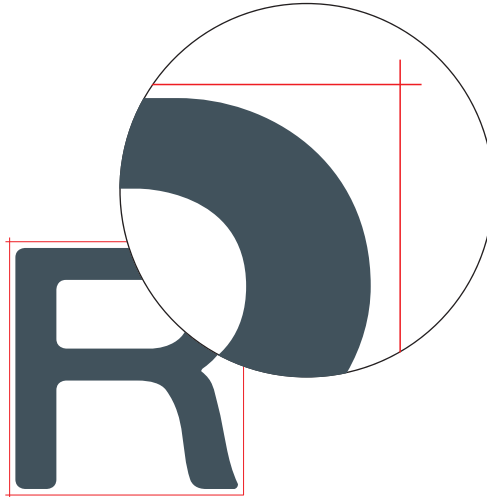

Procedure

1. Set up the media.
2. Click .
3. Select the [Enable Over Cut] check box under [List of Media Settings]>[Over Cut].

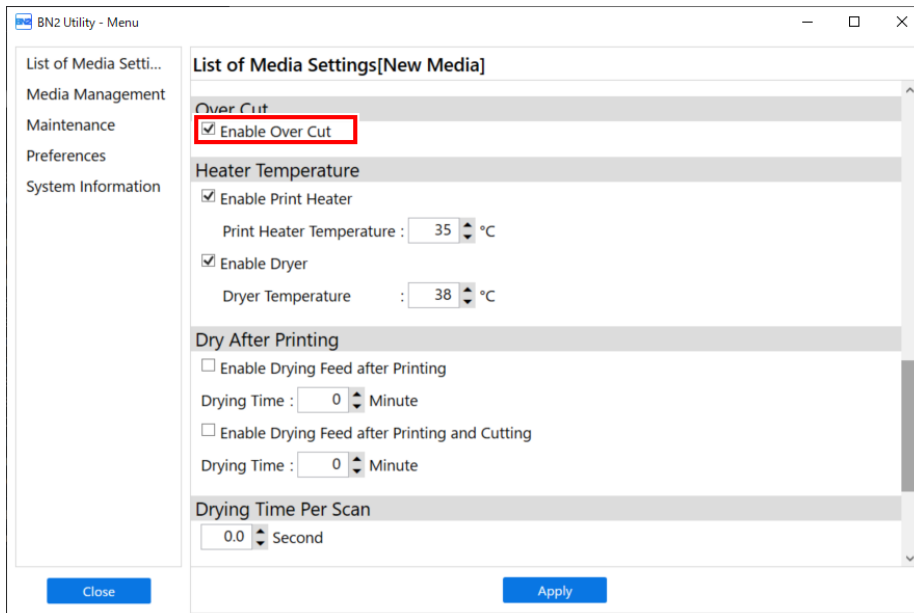

4. Click [Apply] to confirm your entry.
5. Click [Close] to return to the original screen.

MEMO

- Default setting: Off
- The cutting start point is not over cut.

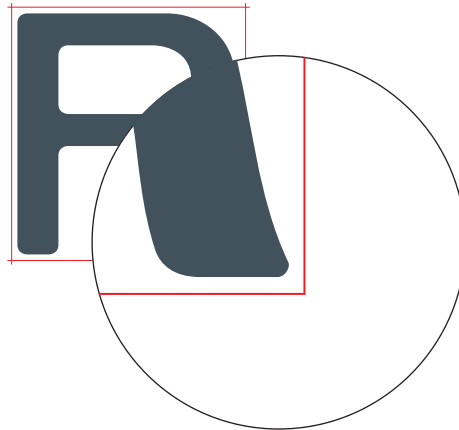

Accurately Adjusting the Settings for Printing and Cutting

Correcting the Misalignment of Printing and Cutting

This is a correction method performed when printing followed immediately by cutting yields positioning for printing and cutting that is slightly misaligned.

Print alignment marks, perform detection of the printed marks, and then correct the discrepancy. Minor misalignment between the printing and cutting positions may occur due to the thickness of the media. We recommend that you make corrections to match the media you are using.

Adjusting the Misalignment of the Ink Landing Position

Procedure

1. Set up the media.
2. Click .
3. Click [Execute] under [List of Media Settings]>[Media Gap Adjustment]>[Simple Correction (Auto)].

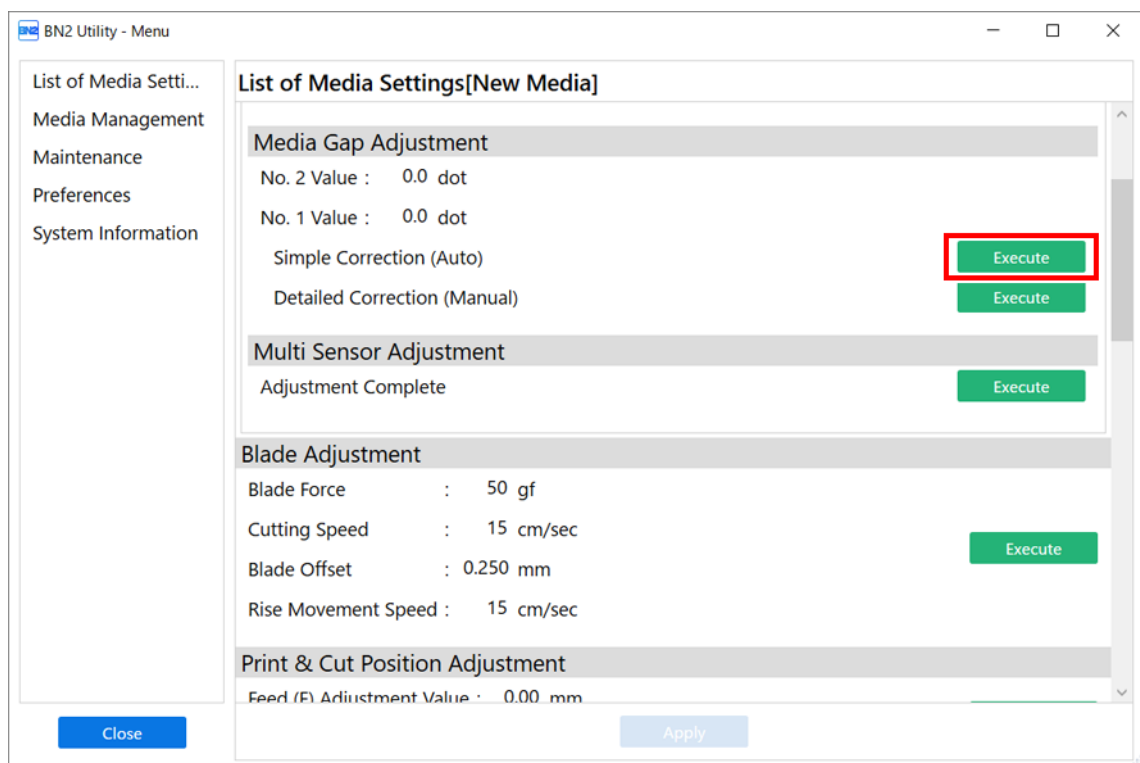

4. Click [OK].
The test pattern is printed and the media gap is adjusted automatically.
5. When a completion screen appears, click [OK].
6. Perform the operations shown below according to the result.
 - If the message [Adjustment has finished.] appears in the Utility window, click [OK] to return to the original screen.

- If the message [Adjustment failed.] appears in the Utility window, click [OK], and then manually adjust the media gap.

RELATED LINKS

- [P. 140 Manual Adjustment: Adjusting the Misalignment of the Ink Landing Position \(Media Gap Adjustment\)](#)

Correcting the Misalignment of Printing and Cutting

This is a correction method performed when printing followed immediately by cutting yields positioning for printing and cutting that is slightly misaligned.

Print alignment marks, perform detection of the printed marks, and then correct the discrepancy. Minor misalignment between the printing and cutting positions may occur due to the thickness of the media. We recommend that you make corrections to match the media you are using.

MEMO

Use the following link to view a reference video for this procedure. We recommend that you view this video to understand the overall flow of work.

<https://vimeo.com/1003475897/fd4a2d1bdd>

The BN2-20/20A is shown in this video, but the work and operation procedures are the same for this machine.

Procedure

1. Click .
2. Click [Execute] under [List of Media Settings]>[Print & Cut Position Adjustment].

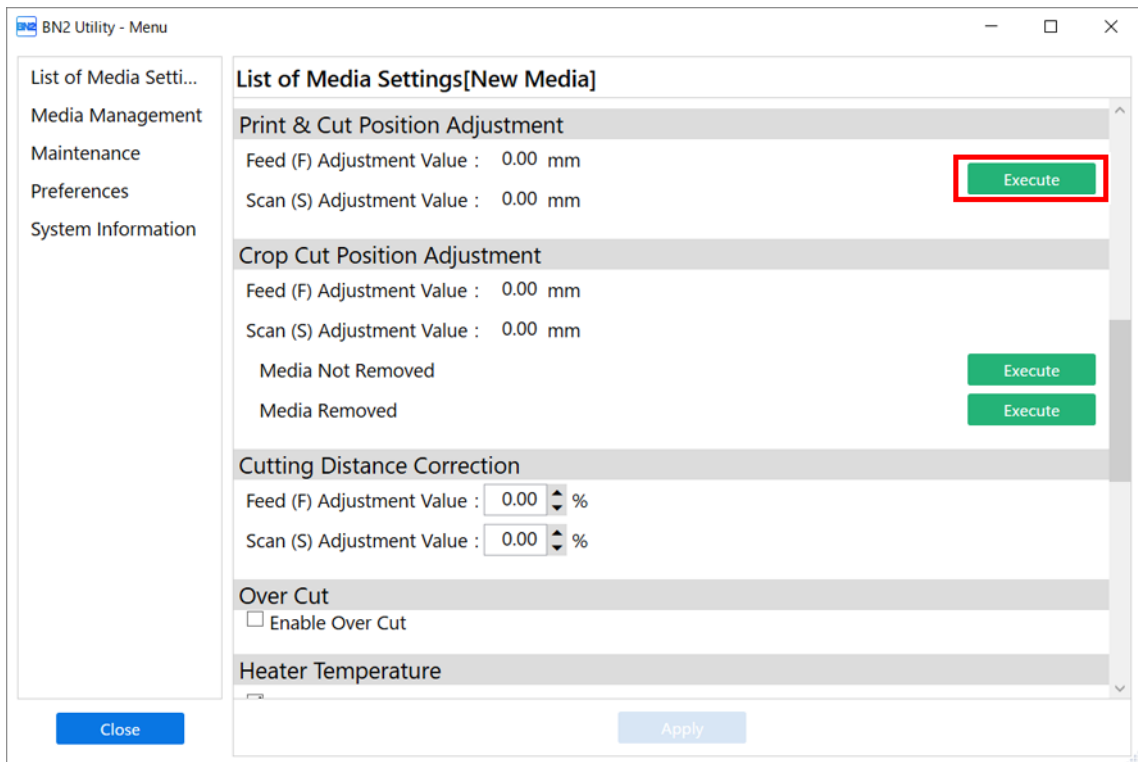

3. Click [Output 1].

The machine prints and cuts the test pattern. View the printing result, checking for misalignment in the printing position and cutting position.

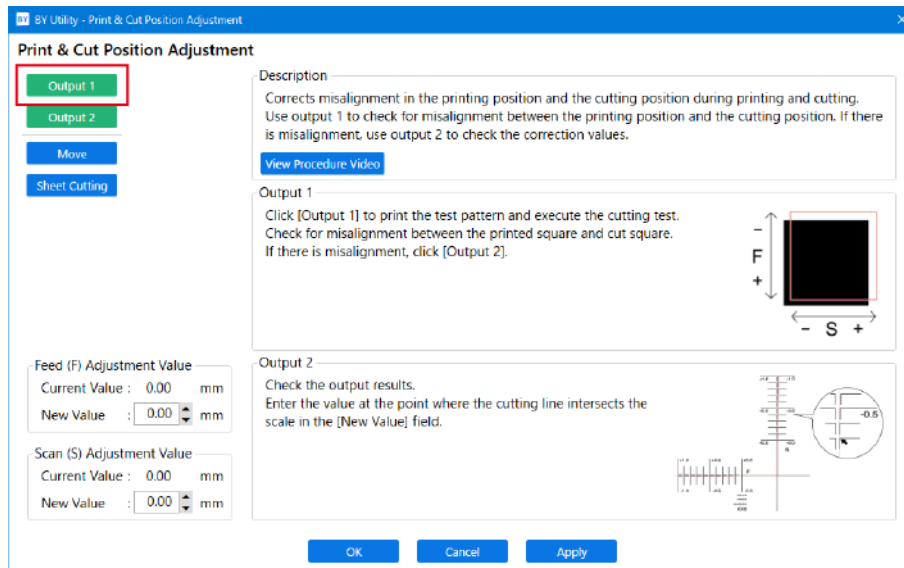

- **If the printing and cutting positions are misaligned**
To determine the correction values, carry out the steps for [Output 2]. Proceed to step 4.
- **If the printing and cutting positions are not misaligned**
This completes the print & cut position adjustment. Click [OK] to return to the original screen.

4. Click [Output 2].

The machine prints and cuts the test pattern.

5. Read the on-screen description and enter each value next to [New Value].

- **[Feed (F) Adjustment Value]:** -5.00 to 5.00 mm (-0.2 to 0.19 in.) (in units of 0.01 mm [0.0003 in.])

Enter the value at the point where the [Output 2] horizontal cutting line intersects the scale.

- **[Scan (S) Adjustment Value]:** -5.00 to 5.00 mm (-0.2 to 0.19 in.) (in units of 0.01 mm [0.0003 in.])

Enter the value at the point where the [Output 2] vertical cutting line intersects the scale.

6. Click [OK] to return to the original screen.

The values entered for [New Value] under [Feed (F) Adjustment Value] and [Scan (S) Adjustment Value] are applied to [Current Value].

Accurately Adjusting the Settings for Cutting with Crop Marks

Correcting the Misalignment of Printing and Cutting with Crop Marks (Crop Cut Position Adjustment [Media Not Removed])

Depending on the composition of the media, the positioning of printing and cutting may be misaligned even when you are using crop marks. Make corrections for misaligned printing and cutting for the media you are using.

In cutting with crop marks, cutting is performed after removing the media after printing. However, with this method, you can make corrections of printing and cutting positions at the same time without removing the media.

Adjusting the Misalignment of the Ink Landing Position

Procedure

1. Set up the media.
2. Click .
3. Click [Execute] under [List of Media Settings]>[Media Gap Adjustment]>[Simple Correction (Auto)].

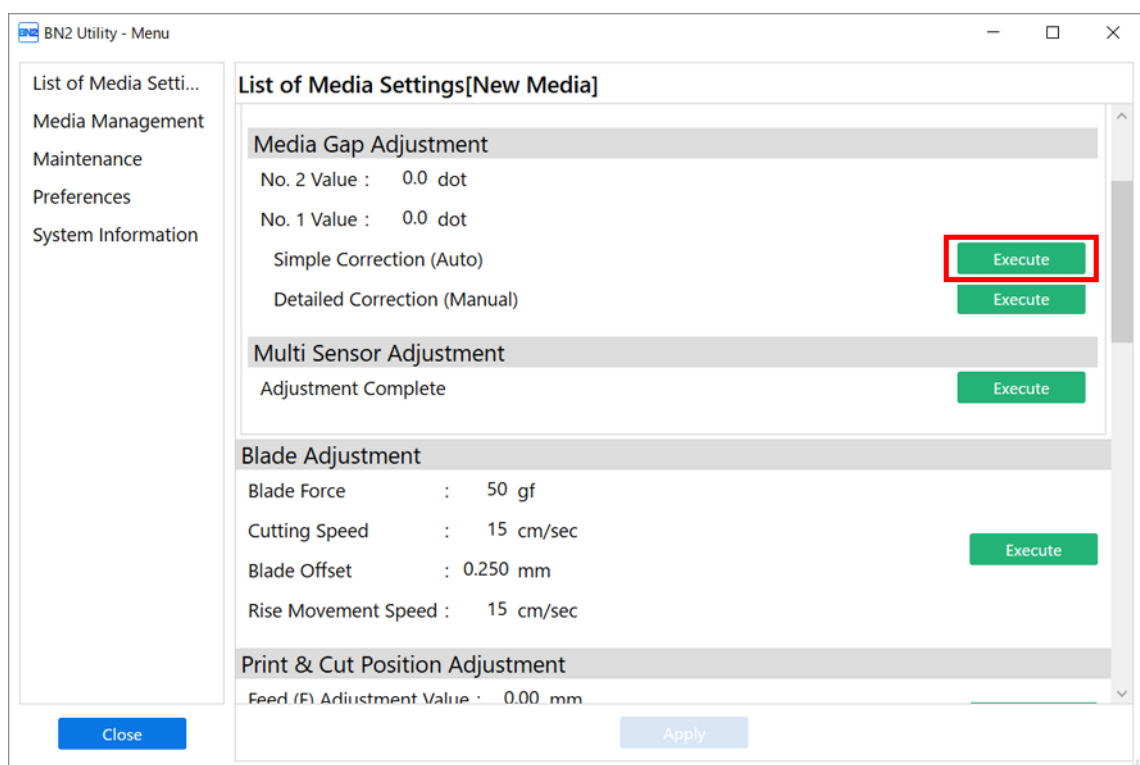

4. Click [OK].
The test pattern is printed and the media gap is adjusted automatically.
5. When a completion screen appears, click [OK].
6. Perform the operations shown below according to the result.

- If the message **[Adjustment has finished.]** appears in the Utility window, click **[OK]** to return to the original screen.
- If the message **[Adjustment failed.]** appears in the Utility window, click **[OK]**, and then manually adjust the media gap.

RELATED LINKS

- [P. 140 Manual Adjustment: Adjusting the Misalignment of the Ink Landing Position \(Media Gap Adjustment\)](#)

✎ Correcting the Misalignment of Printing and Cutting with Crop Marks at the Same Time

Use the following procedure to print the crop marks and cut the media, checking for misalignment in the positions. In this section, the crop marks are printed simply, and then the crop marks are read and a cutting test is performed without removing the media.

To simulate the actual process—printing crop marks, removing the media, and then performing post-processing such as laminating—before loading the media and checking for cutting position misalignment, turn on [Correcting the Misalignment of Printing and Cutting with Crop Marks \(Separate Test for Printing and Cutting with Crop Marks \[Media Removed\]\)](#)(P. 172).

MEMO

Use the following link to view a reference video for this procedure. We recommend that you view this video to understand the overall flow of work.

<https://vimeo.com/1003475517/ad4ccfe84e>

The BN2-20/20A is shown in this video, but the work and operation procedures are the same for this machine.

Procedure

1. Click .
2. Click [Execute] under [List of Media Settings]>[Crop Cut Position Adjustment]>[Media Not Removed].

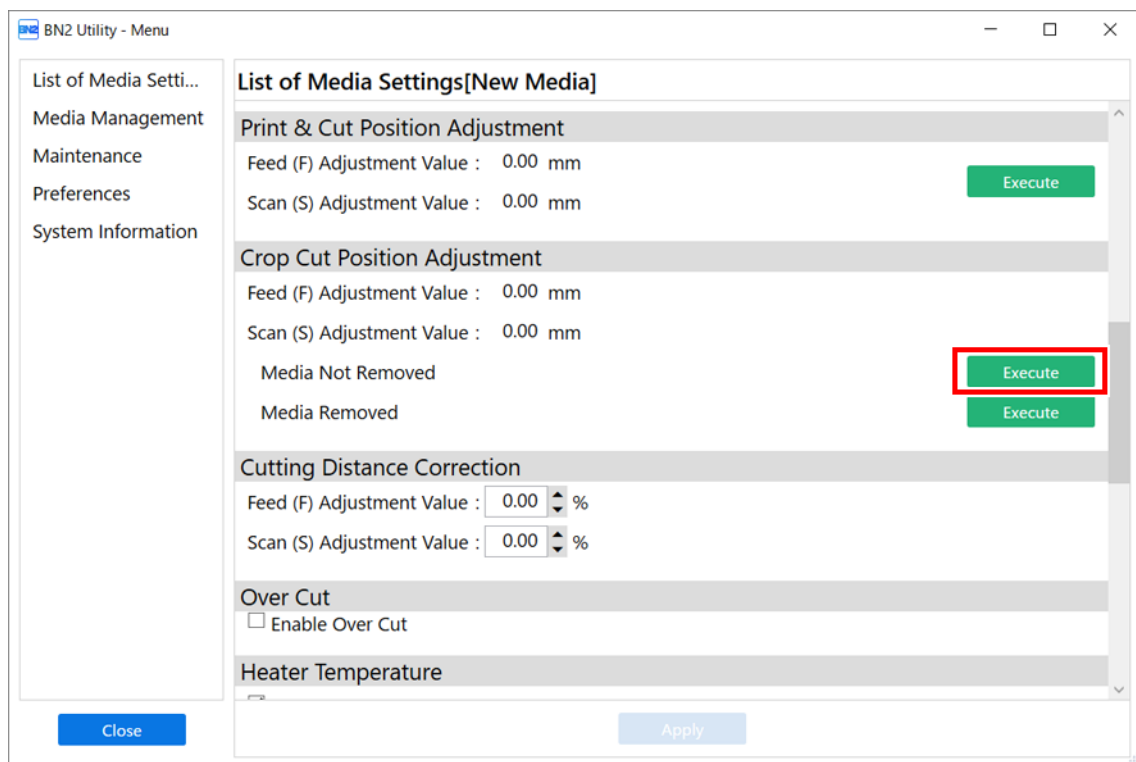

3. Click [Output 1].

The machine prints and cuts the test pattern. View the printing result, checking for misalignment in the printing position and cutting position.

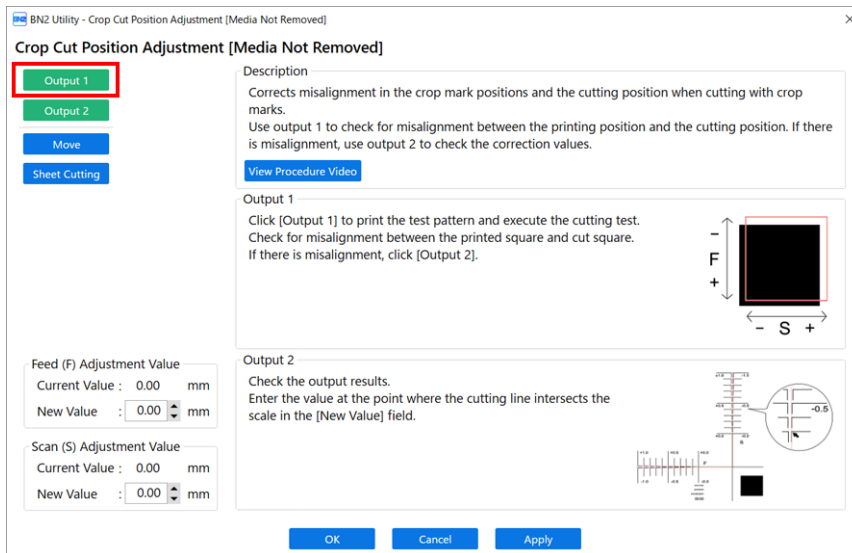

- **If the printing and cutting positions are misaligned**
To determine the correction values, carry out the steps for [Output 2]. Proceed to step 4.
- **If the printing and cutting positions are not misaligned**
This completes the [Crop Cut Position Adjustment]. Click [OK] to return to the original screen.

4. Click [Output 2].

The machine prints and cuts the test pattern.

5. Check the correction values from the Printing Test 2 condition.

The point where the cutting line (A) intersects the correction-value scale (B) is the correction value. In the following figure, the correction value is "-0.3."

Check the media feed direction (the feed direction) and the direction of print-head carriage movement (the scan direction).

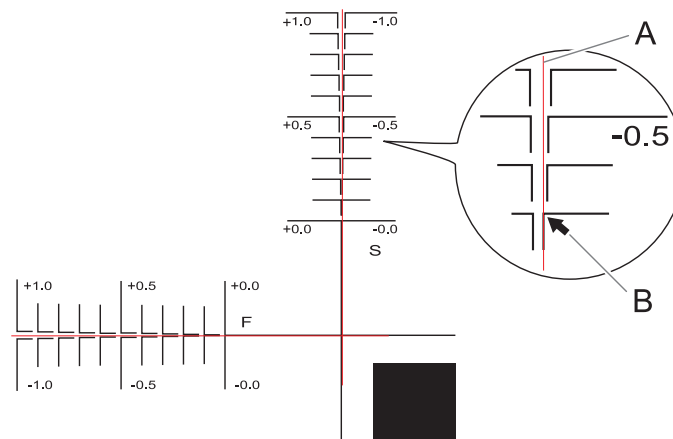

6. Read the on-screen description and enter each value next to [New Value].

- **[Feed (F) Adjustment Value]:** -2.00% to 2.00% (in units of 0.01%)
Enter the value at the point where the [Output 2] horizontal cutting line intersects the scale.
- **[Scan (S) Adjustment Value]:** -2.00% to 2.00% (in units of 0.01%)
Enter the value at the point where the [Output 2] vertical cutting line intersects the scale.

7. Click [Apply].

The values entered for [New Value] under [Feed (F) Adjustment Value] and [Scan (S) Adjustment Value] are applied to [Current Value].

8. Click [Output 1] again.

The machine prints and cuts the test pattern again.

- If the printing and cutting lines are aligned, adjustment is complete. Click [OK] to return to the original screen.
- If further adjustment is needed, change the [Feed (F) Adjustment Value] and [Scan (S) Adjustment Value] values to fine-tune the printing and cutting position.

When the adjustment is finished, click [OK] to return to the original screen.

MEMO

- Default settings
 - [Feed (F) Adjustment Value] (correction value of the media feed direction): 0.00 mm
 - [Scan (S) Adjustment Value] (correction value of the print-head carriage movement direction): 0.00 mm
- Depending on the changes in the condition of media caused by laminating and the loading position of the media before cutting, the positioning of cutting may be misaligned. In such cases, correct the misalignment of printing and cutting with crop marks.

RELATED LINKS

- [P. 172 Correcting the Misalignment of Printing and Cutting with Crop Marks \(Separate Test for Printing and Cutting with Crop Marks \[Media Removed\]\)](#)

Correcting the Misalignment of Printing and Cutting with Crop Marks (Separate Test for Printing and Cutting with Crop Marks [Media Removed])

Due to changes in the thickness of media caused by laminating and misalignment of the loading position of the media before and after cutting, the positioning of printing and cutting may be misaligned even when you are using crop marks. Make corrections for misaligned printing and cutting for the media you are using and its condition.

In this test, so as to create the same conditions as the actual operation, print only the crop marks, remove the media, load the media again, and then cut the media.

Adjusting the Misalignment of the Ink Landing Position

Procedure

1. Set up the media.
2. Click .
3. Click [Execute] under [List of Media Settings]>[Media Gap Adjustment]>[Simple Correction (Auto)].

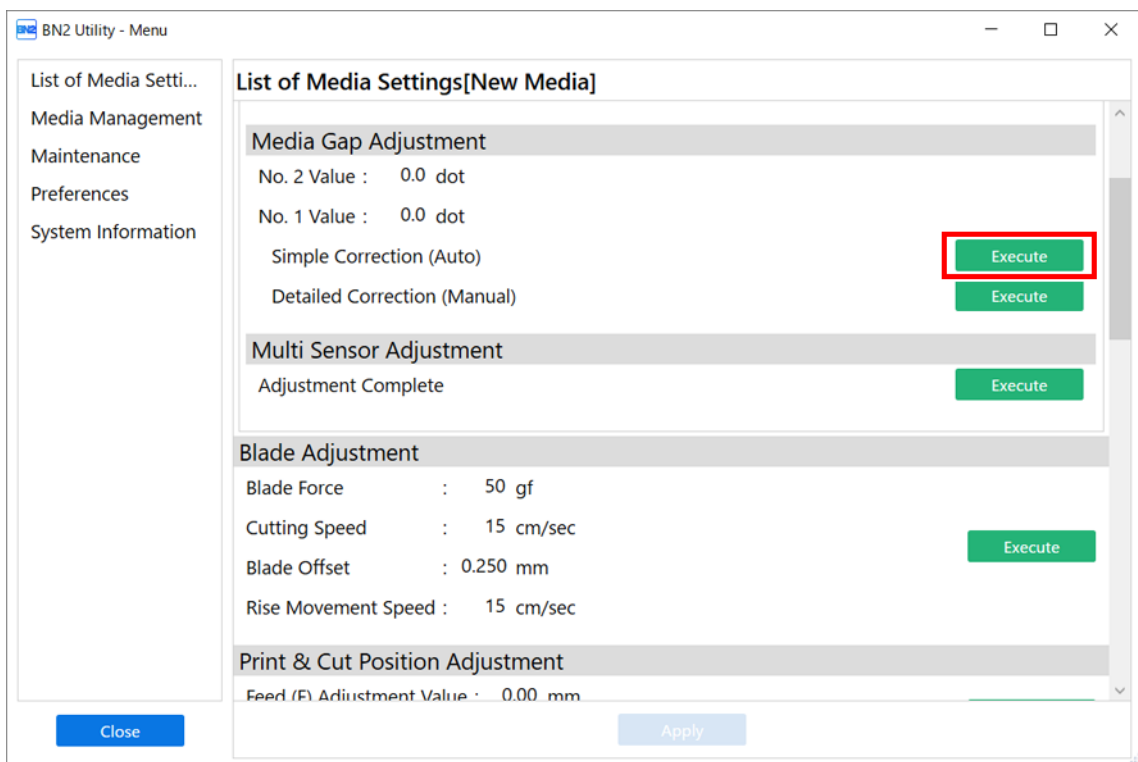

4. Click [OK].
The test pattern is printed and the media gap is adjusted automatically.
5. When a completion screen appears, click [OK].
6. Perform the operations shown below according to the result.
 - If the message [Adjustment has finished.] appears in the Utility window, click [OK] to return to the original screen.

- If the message [Adjustment failed.] appears in the Utility window, click [OK], and then manually adjust the media gap.

RELATED LINKS

- [P. 140 Manual Adjustment: Adjusting the Misalignment of the Ink Landing Position \(Media Gap Adjustment\)](#)

Printing Only the Crop Marks

MEMO

Use the following link to view a reference video for this procedure. We recommend that you view this video to understand the overall flow of work.

<https://vimeo.com/1003475368/aff4a7e5a5>

The BN2-20/20A is shown in this video, but the work and operation procedures are the same for this machine.

Procedure

1. Click .
2. Click [Execute] under [List of Media Settings]>[Crop Cut Position Adjustment]>[Media Removed].

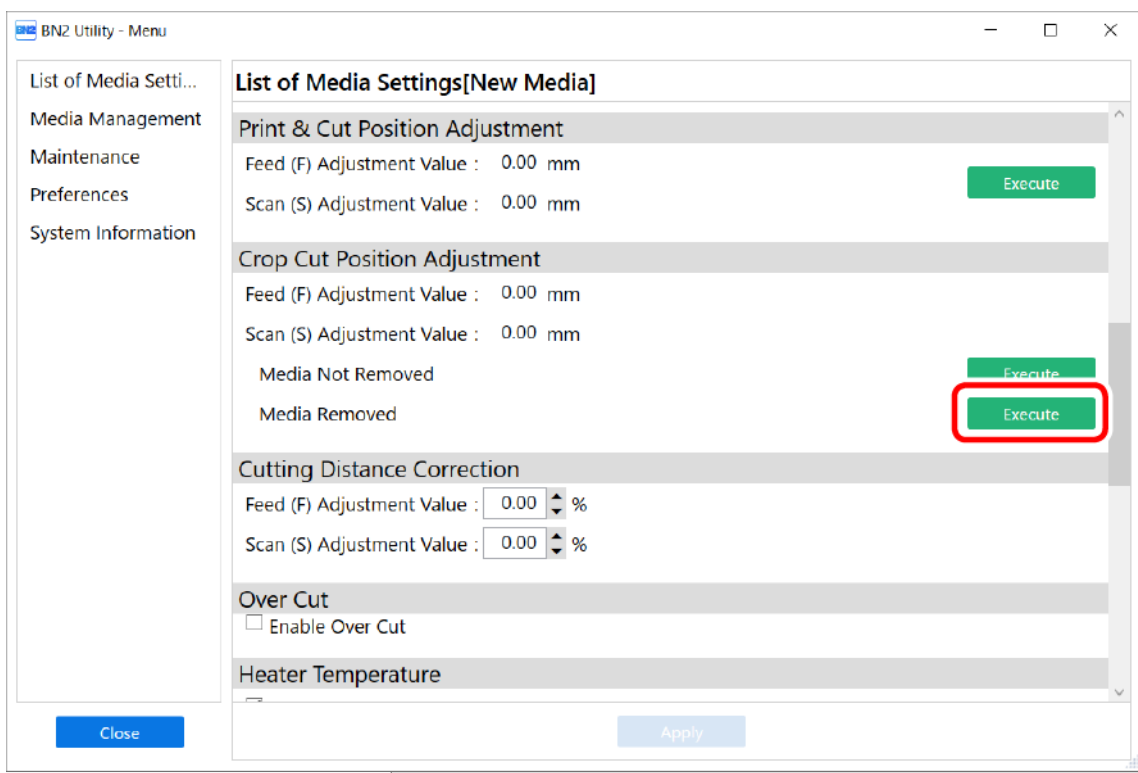

3. Click [Printing Output].
 Printing of the test pattern starts.
 The crop marks are printed. When printing is finished, you will return to the original screen.
4. Remove any media.
 Use the following procedure to separate the media.
 - (1) Close the front cover.
 - (2) Click [Move].
 - (3) Click  to feed the media until there is a margin of 100 mm (3.94 in.) or more after the printed crop marks.

(4) Click  to return to the previous screen.

(5) Click [Sheet Cutting].

(6) Select [Sheet Cutting] for the sheet cutting method, and then click [OK].





5. Complete operations before cutting output for normal cutting with crop marks, such as laminating.

Performing a Cutting Test

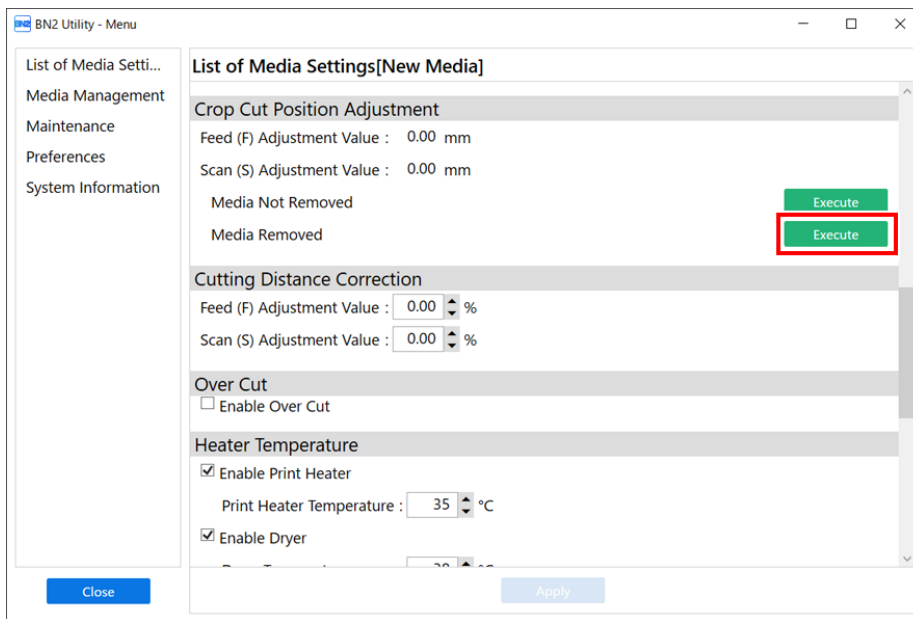
Procedure

1. Set up the media for which operations before cutting output, such as lamination, is complete.
2. Click .
3. Click [Execute] under [List of Media Settings]>[Crop Cut Position Adjustment]>[Media Removed].



4. Click [Cutting Output].
The [Move the blade over a crop mark.] window appears.
5. Click , , , or  to move the center of the blade over the crop marks to use in the cutting test.
The center of the blade should only be over the crop marks, and does not need to be aligned with the center of the crop marks.

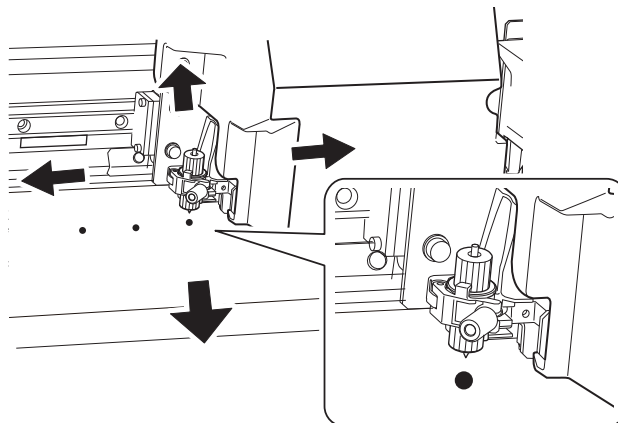

6. Click [OK].
The cutting test starts.

Setting the Correction Values

Procedure

1. View the results of the cutting test to determine the correction values.

Check whether the crop mark (shaded part) and the cutting position are aligned. An example of the crop mark and the cutting position being misaligned is shown in the following figure.

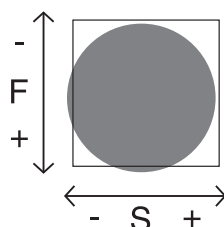

- If the test printed crop marks are inside the cutting line, correction is not necessary.
- If the test printed crop marks are extending beyond the cutting line, correction is necessary.

[F] indicates the feed direction of the media (the feed direction) and [S] indicates the direction of print-head carriage movement (the scan direction). ("F," "S," "+," "-", and the arrows are not displayed on the actual test pattern.)

MEMO

Determine the values so as to correct the misalignment of the cutting position. In the case of the above figure, feed direction [F] is misaligned in a negative direction and scan direction [S] in a positive direction. Therefore, set the correction values for feed direction [F] to positive values and scan direction [S] to negative values. Measure the actual misalignment amount when determining the value.

2. Set the correction values in the feed direction of the media (the feed direction) and the direction of print-head carriage movement (the scan direction).

- (1) Enter the correction value in [New Value] for [Feed (F) Adjustment Value] to set the correction value in the feed direction of the media (the feed direction).
- (2) Enter the correction value in [New Value] for [Scan (S) Adjustment Value] to set the correction value in the direction of print-head carriage movement (the scan direction).

3. Click [Apply].

4. Perform steps 5 to 7 of [Performing a Cutting Test\(P. 176\)](#) again to check whether the correction was successful.

- If the test printed crop marks are inside the cutting line, correction is complete. Click [OK] to return to the original screen.
- If the test printed crop marks are extending beyond the cutting line, redo the correction.

MEMO

- Default settings
 - [Feed (F) Adjustment Value] (correction value of the media feed direction): 0.00 mm
 - [Scan (S) Adjustment Value] (correction value of the print-head carriage movement direction): 0.00 mm

MEMO

You can also make corrections of printing and cutting positions at the same time without removing the media.

RELATED LINKS

- [P. 167 Correcting the Misalignment of Printing and Cutting with Crop Marks \(Crop Cut Position Adjustment \[Media Not Removed\]\)](#)

Correcting the Reading Sensor (Multi Sensor Adjustment)

Depending on the characteristics of the media, such as reflectivity and colors, the machine may not be able to read the crop marks. In such cases, correct the sensor for reading crop marks. If you are not cutting with crop marks, operation is not affected even if a failure is displayed.

Procedure

1. Set up the media.
2. Click .
3. Click [List of Media Settings]>[Multi Sensor Adjustment]>[Execute].

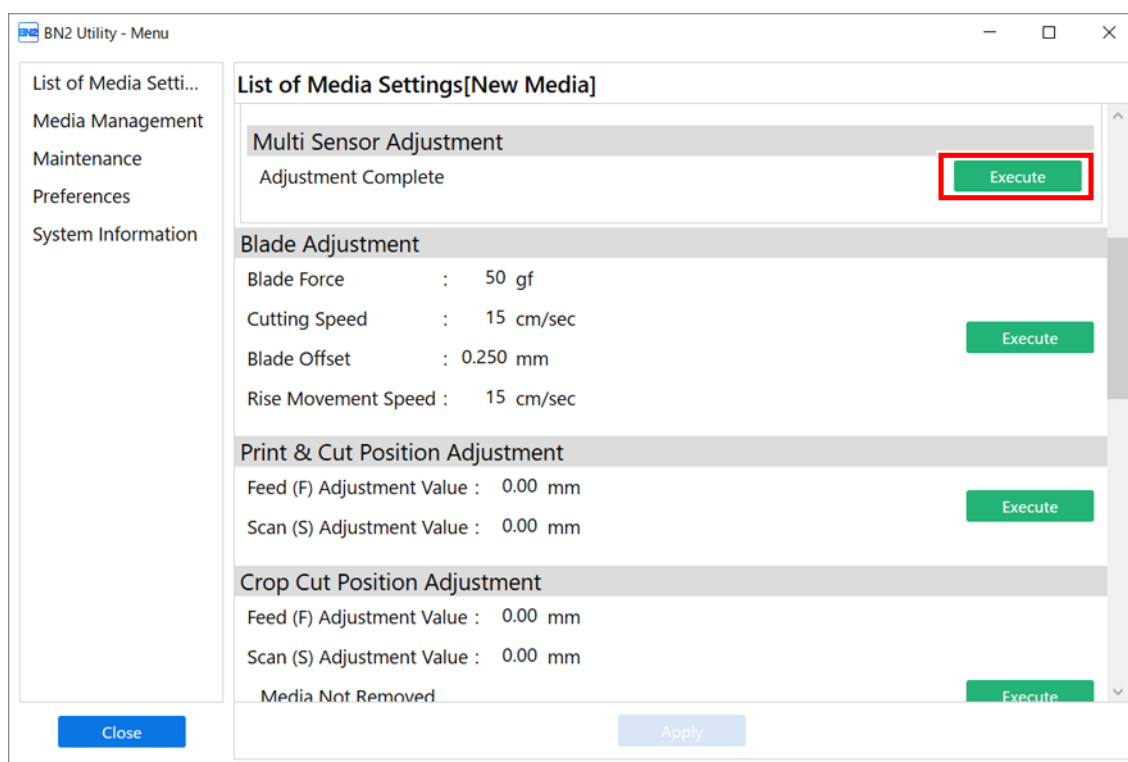

4. Click [OK].
Adjust the sensor. The adjustment results appear.

- [Adjustment has finished.]:
Click [OK] to return to the original screen.
- [Adjustment failed.]:
Check the following items.

Cause	Countermeasures
The lighting in the room where the printer is installed or vicinity of the printer is too bright.	Adjust the lighting in the room.
Correction failed for some reason.	Redo the correction.
Crop marks cannot be recognized on the media being used.	Change the media type.
There is ink on the multi sensor because, for example, the media strikes it immediately after printing.	Contact your authorized dealer.

Optimizing Work Efficiency

Managing the Media Settings.....	181
Changing the Media Settings	181
Checking the Registered Media Settings	183
Changing the Media Name	185
Duplicating Media Settings.....	186
Deleting Media Settings	188
Adjusting the Output-start Location.....	189
Setting the Base Point	189
Reducing Output Time	192
Speeding Up Output for Narrow Media.....	192
Other Functions.....	193
Adjusting the Right Media Clamp Position.....	193
Performing Printing Tests Arranged Horizontally	194

Managing the Media Settings

Changing the Media Settings

Use the following procedure to change the media settings. These settings can only be changed for the media being set up.

Procedure

1. Set up the media.
2. Click .
3. Click [List of Media Settings].
The media setting values are displayed in a list.

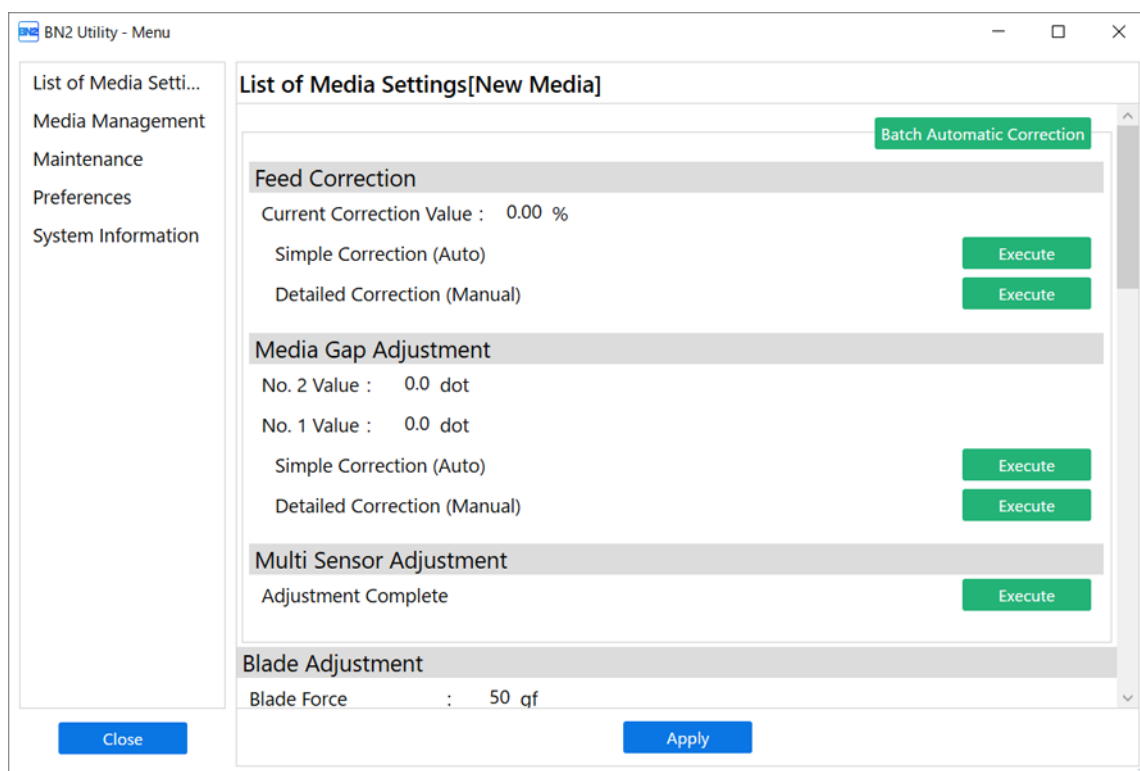

4. Click the setting to change to move to the screen for editing this setting.
The media settings that can be changed are as follows.

Menu item	Reference page
[Batch Automatic Correction]	Performs [Multi Sensor Adjustment], simple (automatic) correction for [Feed Correction], and simple (automatic) correction for [Media Gap Adjustment]. P. 136 Automatically Making Required Adjustments
[Feed Correction]	P. 138 Manual Adjustment: Reducing Horizontal Bands (Feed Correction)
[Media Gap Adjustment]	P. 140 Manual Adjustment: Adjusting the Misalignment of the Ink Landing Position (Media Gap Adjustment)
[Multi Sensor Adjustment]	P. 179 Correcting the Reading Sensor (Multi Sensor Adjustment)

Menu item	Reference page
[Blade Adjustment]	P. 157 Fine-tuning the Cutting Conditions
[Print & Cut Position Adjustment]	P. 115 Correcting the Misalignment of Printing and Cutting
[Crop Cut Position Adjustment]	P. 167 Correcting the Misalignment of Printing and Cutting with Crop Marks (Crop Cut Position Adjustment [Media Not Removed]) P. 172 Correcting the Misalignment of Printing and Cutting with Crop Marks (Separate Test for Printing and Cutting with Crop Marks [Media Removed])
[Cutting Distance Correction]	P. 160 Performing Distance Correction during Cutting
[Over Cut]	P. 161 Cutting to Make It Possible to Cut Corners Attractively (Over Cut)
[Heater Temperature]	P. 149 Setting the Print Heater Temperature P. 151 Setting the Dryer Temperature
[Dry After Printing]	P. 155 Drying the Trailing Edge of the Printing Area on the Dryer
[Drying Time Per Scan]	P. 142 Using Hard-to-Dry Media
[Media Suction Force]	P. 143 Using Media That Wrinkles Easily/Does Not Move Smoothly
[Printing Movement Range]	P. 192 Speeding Up Output for Narrow Media
[Media Sticking Prevention]	P. 144 Using Sticky Media

5. If you have changed a setting on the [List of Media Settings] window, click [Apply].
6. Click [Close] to return to the original screen.

Checking the Registered Media Settings

Procedure

1. Click .
2. Click [Media Management].

The registered media are displayed in a list.

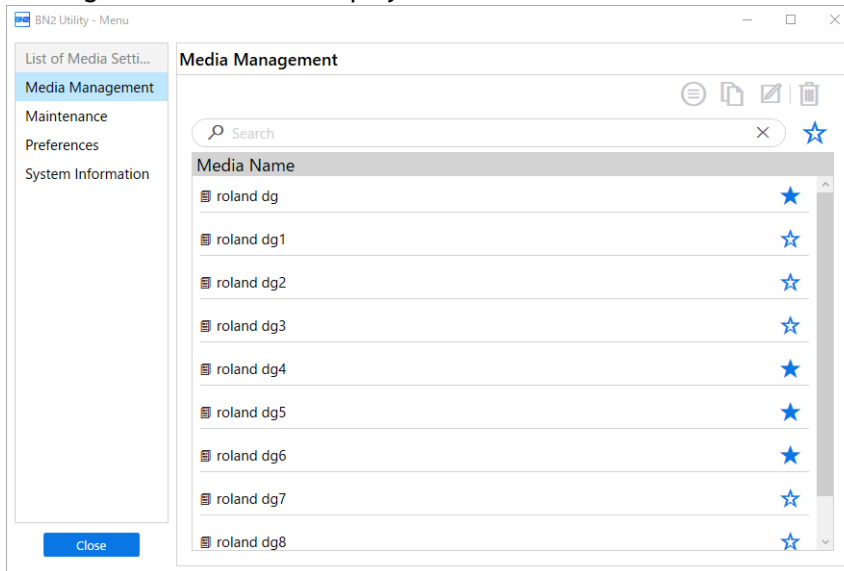

3. Select the name of the media whose settings you will check, and then click .

The list of registered media settings appears.

IMPORTANT

Settings cannot be changed from this window.
To change settings, refer to [Changing the Media Settings](#).

List of Media Settings
[Feed Correction]
[Media Gap Adjustment]
[Multi Sensor Adjustment]
[Blade Adjustment]
[Print & Cut Position Adjustment]
[Crop Cut Position Adjustment]
[Cutting Distance Correction]
[Over Cut]
[Heater Temperature]
[Dry After Printing]
[Drying Time Per Scan]
[Media Suction Force]
[Printing Movement Range]

List of Media Settings
[Media Sticking Prevention]

- 4. Click [OK] to return to the original screen.

Changing the Media Name

Procedure

1. Click .

2. Click [Media Management].

The registered media are displayed in a list.

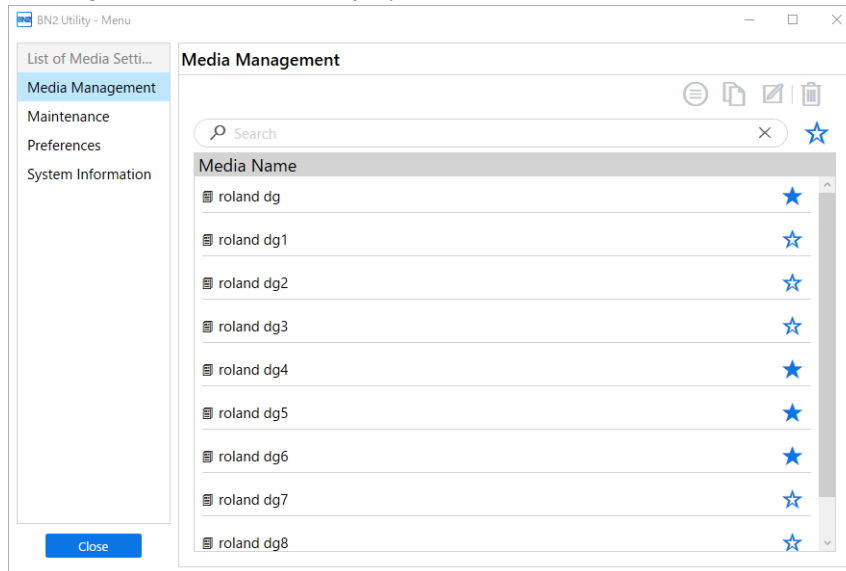

3. Click the media whose name you want to change.

4. Click .

5. Enter a media name, and then click [OK] to confirm your entry.

6. Click [Cancel] to return to the original screen.

Duplicating Media Settings

Use the following procedure to duplicate existing media settings.

Procedure

1. Click .
2. Click [Media Management].

The registered media are displayed in a list.

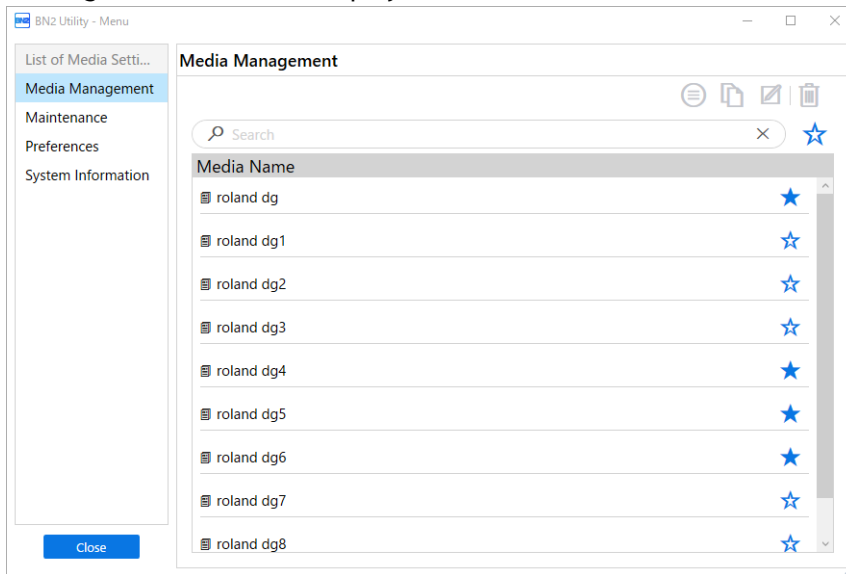

3. Select the media setting to be duplicated, and then click .
4. Set the content to be duplicated according to the procedure below.
 - (1) Enter the desired media name.
 - (2) Select either [Print Only/Print & Cut] or [Cut Only].

MEMO

- [Print Only/Print & Cut]: The selected media settings are duplicated.
- [Cut Only]: The selected media settings are duplicated with the settings configured so the heater power is off.

- (3) Click [OK].

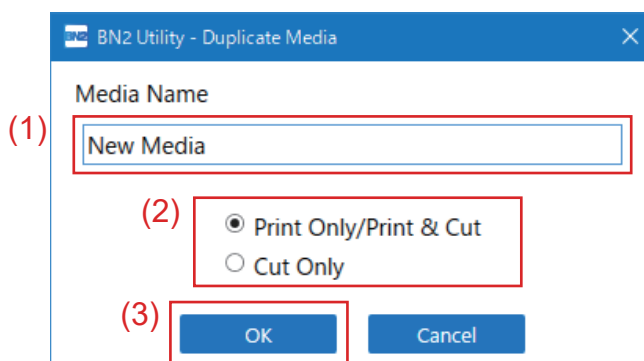

5. Click [Cancel] to return to the original screen.

Deleting Media Settings

Use the following procedure to delete existing media settings.

MEMO

This operation cannot be performed on the media being set up. To perform this operation, first cancel media setup.

Procedure

1. Click .
2. Click [Media Management].

The registered media are displayed in a list.

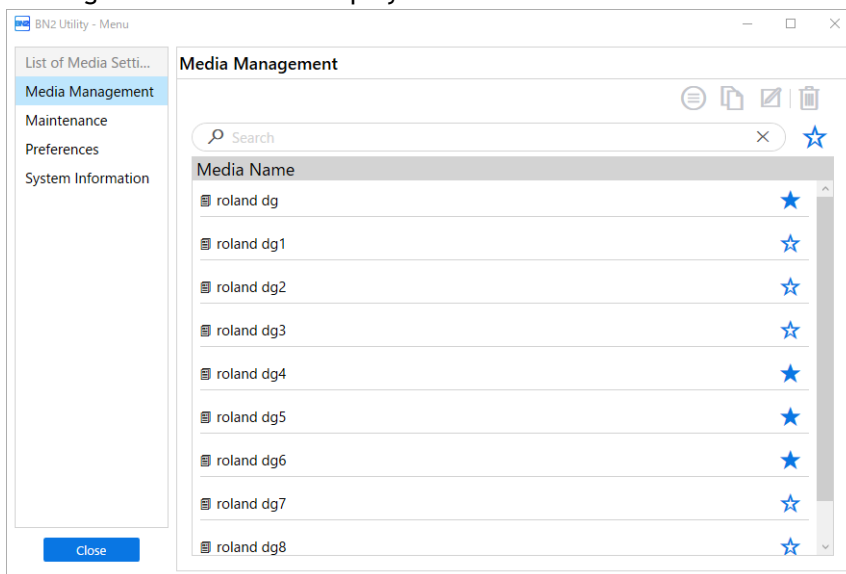

3. Select the media setting to be deleted, and then click .
4. When the confirmation window appears, click [OK].
The media setting is deleted, and you are returned to the media management window.
5. Click [Cancel] to return to the original screen.

Adjusting the Output-start Location

Setting the Base Point

Set the base point in order to determine the area on the loaded media in which to print (the output area).

The base point (④) indicates the right edge of the output area (①). (②: Media feed direction, ③: print-head carriage movement direction) You can print without setting the base point, but setting the output area enables you to use media without being wasteful and also to print on the targeted location.

Set the base point for each individual output. When one output finishes, the base point returns to its default value.

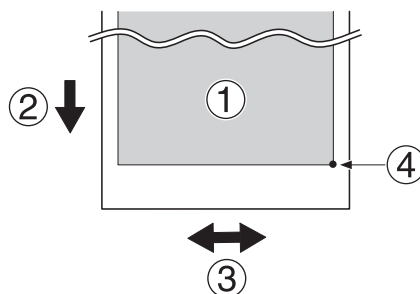

MEMO

Note that the left and right positions are not restored to their defaults for test patterns.

Procedure

1. Set up the media.

2. Click  [Move].

The [Move] window appears.

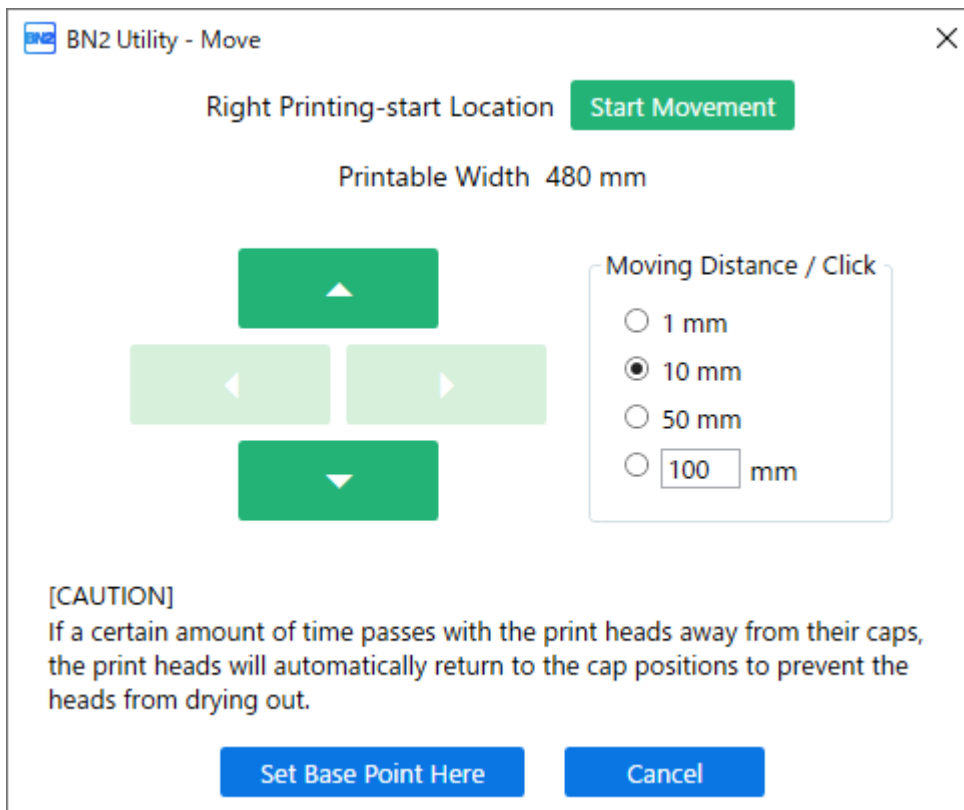

3. Select [Moving Distance / Click].





MEMO





The [Moving Distance / Click] value can also be entered as desired.

4. Click [Start Movement].

The media and the print-head carriage move to the current base point.

IMPORTANT





If 20 seconds elapse without , , , or  being pressed or if 3 minutes elapse from the start of setup, to prevent the print heads from drying out, the print-head carriage returns to the position from before it started moving. Start the setup again after the drying prevention operation finishes.

5. Click , , , or  to move the center of the blade to the position that you want to set as the base point.

MEMO

To continue moving the blade, wait for the print-head carriage or media operation to stop, and then click these buttons again.

MEMO

Click  or  to move the print-head carriage. Click  or  to feed or pull back the media.

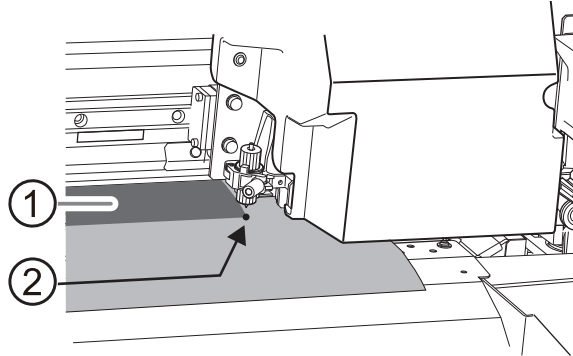

- ①: Output area
- ②: Base point (right edge of the output area)

6. Once the position has been decided, click [Set Base Point Here] to confirm it.

The base point is set to the current position of the center of the blade, and you are returned to the home screen.

MEMO

The display of the icon on the home screen changes to indicate that the base point position has been updated.

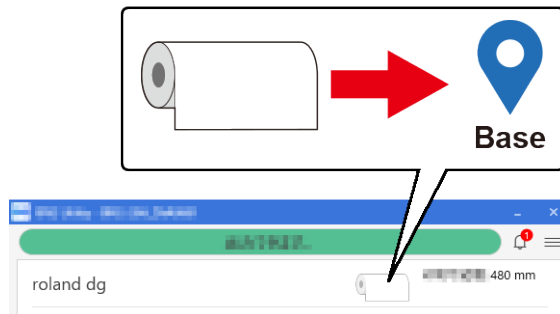

Reducing Output Time

Speeding Up Output for Narrow Media

This shortens output time by reducing the width of head movement to the minimum necessary. This is effective when the width of the media or the output data is narrow.

Procedure

1. Set up the media.
2. Click .
3. From [List of Media Settings]>[Printing Movement Range], specify the range of print-head carriage movement during printing.

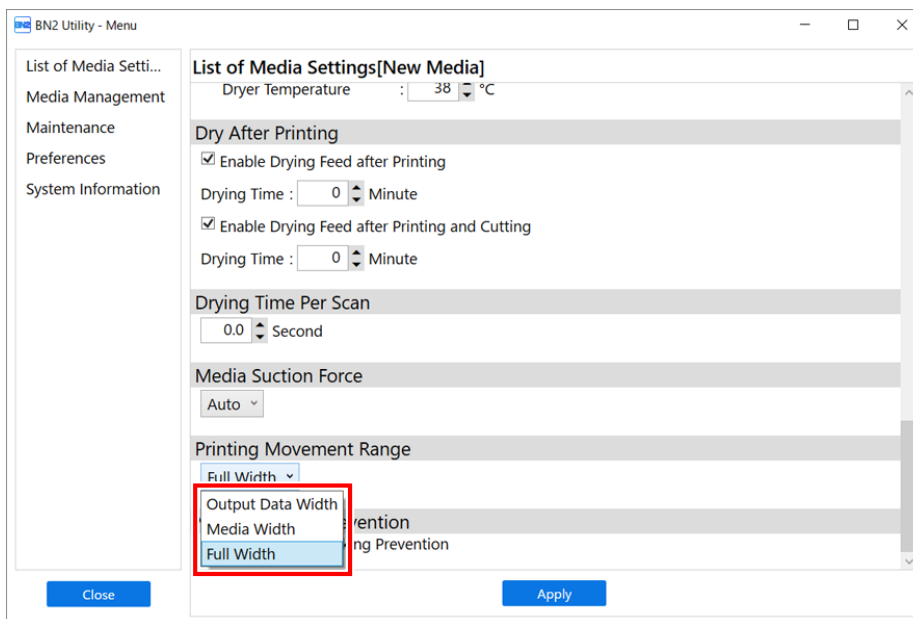

[Output Data Width]	Matches the range of print-head carriage movement to the output data. Movement is limited to the minimum amount necessary, and this can be expected to yield the fastest output. Note, however, that because the speed of media movement is no longer constant, colors may be uneven.
[Media Width]	"SHEET" matches the range of print-head carriage movement to the width of the media.
[Full Width]	The print-head carriage moves from one end of the machine to the other. Makes the speed of media movement constant at all times and produces the most stable printing result.

4. Click [Apply] to confirm your entry.
5. Click [Close] to return to the original screen.

MEMO

- Default setting: [Full Width]

Other Functions

Adjusting the Right Media Clamp Position

Carry out this procedure when it is necessary to adjust the right media clamp position, such as when you load sheet media. When you execute this function, the print-head carriage moves to the left, allowing you to move the right media clamp.

MEMO

This operation cannot be performed when media has been set up. To perform this operation, first cancel setup.

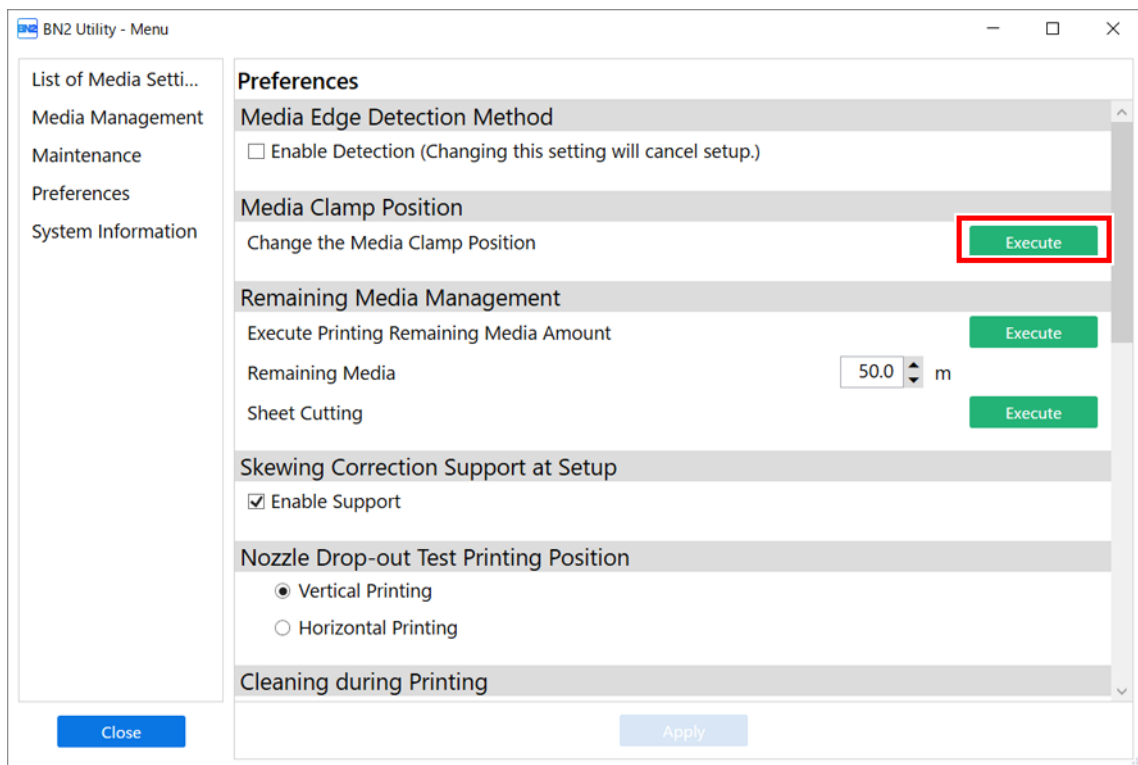

Procedure

1. Click .
2. Click [Execute] under [Preferences]>[Media Clamp Position].
The print-head carriage moves to the left, allowing you to adjust the right media clamp position.
3. Follow the instructions in the Utility window to adjust the right media clamp position.
 - (1) Open the front cover.
 - (2) Adjust the right media clamp position.
 - (3) Close the front cover.
 - (4) Click [Finish].
4. Click [Close] to return to the original screen.

Performing Printing Tests Arranged Horizontally

When performing printing tests successively, you can select [Vertical Printing] or [Horizontal Printing] as the printing position for the second and later tests in comparison to the first test.

Procedure

1. Click .
2. Select [Horizontal Printing] for [Preferences]>[Nozzle Drop-out Test Printing Position].
3. Click [Apply] to confirm your entry.
4. Click [Close] to return to the original screen.

MEMO

Default setting: [Vertical Printing]

Optimizing Operation Management

Managing the Operations Appropriately and Efficiently	196
Checking the Remaining Media	196
Printing the Amount of Remaining Media	198
Setting the Activation Interval for Sleep Mode (Power-saving Feature)	199
Setting the Duration of the Warning Beep	200
Managing the Basic Settings of the Printer	201
Changing the Units of Measurement	201
Viewing Printer Information	202
Viewing Network Information	203
Changing the Network Settings	204
Returning Adjustments to Their State Prior to the Initial Settings	212
Resetting All Adjustments to Factory Default Values	213

Managing the Operations Appropriately and Efficiently

Checking the Remaining Media

Use the following procedure to display on the Utility home screen the remaining amount of the in-use media. If you set the amount of media currently remaining at the start, the amount remaining will be constantly displayed until it reaches zero.

The display of the amount of media remaining is not updated automatically when you change the media. Redo the setting whenever you change the media.

MEMO

The remaining amount that is displayed is only an estimate. Accuracy is not assured.

Procedure

1. Set up the media.
2. Click .
3. Set [Remaining Media] under [Preferences]>[Remaining Media Management] to the length of the remaining media.

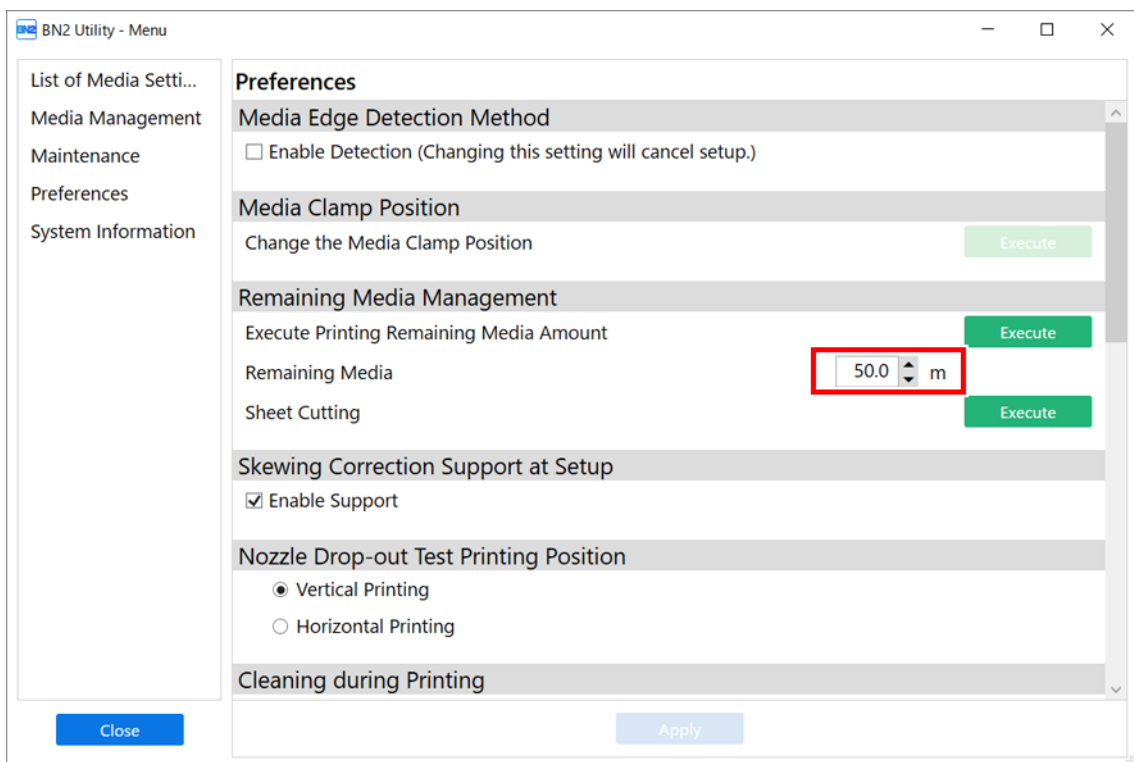

4. Click [Apply] to confirm your entry.
5. Click [Cancel] to return to the original screen.
The amount of media remaining is displayed on the Utility home screen.

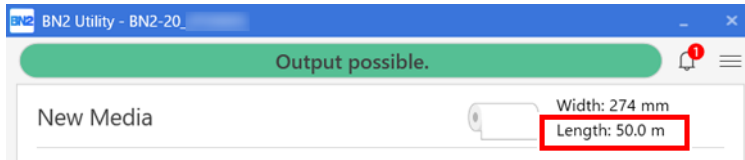

Printing the Amount of Remaining Media

Use the following procedure to print the amount of remaining media, which is displayed on the Utility home screen.

Use this when you want to make a record of the remaining length of the media currently in use. Printing the amount of media remaining before you change the media enables you to refer to the printed record and use the value to make the setting for the remaining amount the next time you use the media.

Note, however, that if you continue printing, the next printing operation will start on top of the portion where the amount of remaining media is printed. If you want to continue printing, separate the media before starting the next printing operation.

Procedure

1. Set up the media.
2. Check that the amount of remaining media is displayed on the home screen.
If it is not, set the amount of remaining media by referring to the following section.
[P. 196 Checking the Remaining Media](#)
3. Click .
4. Click [Execute] under [Preferences]>[Remaining Media Management]>[Execute Printing Remaining Media Amount].
The amount of remaining media is printed.
5. Click [Close] to return to the original screen.

Setting the Activation Interval for Sleep Mode (Power-saving Feature)

This setting is used to set how long it should take until the machine goes into sleep mode (the state in which the power-saving feature is working) when no output data is received and no operations are performed for a continued length of time.

Procedure

1. Click .
2. From [Preferences]>[Sleep Time], set the interval until activation of the sleep mode.
3. Click [Apply] to confirm your entry.
4. Click [Close] to return to the original screen.

MEMO

- Default setting: [30 min]

Setting the Duration of the Warning Beep

This feature sets the duration of the warning beep that sounds when, for example, an error occurs. If you turn this timer off, the warning beep will continue until the cause of the problem is eliminated.

Procedure

1. Click ☰.
2. Click the [Preferences]>[Stopping the Warning Beep] pull-down menu.
3. Setting the Duration of the Warning Beep
4. Click [Apply] to confirm your entry.
5. Click [Close] to return to the original screen.

MEMO

- Default setting: Off

Managing the Basic Settings of the Printer

Changing the Units of Measurement

Use the following procedure to set the units of measurement displayed in the Utility window.

Procedure

1. Click .
2. Select the [Length] and [Temperature] with [System Information]>[Units].
3. Click [Apply] to confirm your entry.
4. Click [Close] to return to the original screen.
Changes to the display unit settings are applied when you restart Utility.

MEMO

- Default settings
 - [Length]: mm
 - [Temperature]: °C

RELATED LINKS

- [P. 15 Starting/Exiting Utility](#)

Viewing Printer Information

This is a method for viewing information of this machine, such as serial number and ink type.

Procedure

1. Click .
2. Check the [System Information]>[Machine Information].
You can check the following information:
 - [Model]: Model name
 - [Nickname]: Nickname of the machine
 - [Serial Number]: Serial number of the machine
 - [Ink Type]: Ink type
 - [Firmware Version]
 - [MAC Address]
3. Click [Close] to return to the original screen.

Viewing Network Information

Use the following procedure to view network information such as the IP address and default gateway.

Procedure

1. Click .
2. Check the [System Information]>[Network].
You can check the following information:
 - [Obtain IP Address Automatically]: Enables/disables the automatic obtaining of IP addresses via DHCP.
 - [IP Address]
 - [Subnet Mask]
 - [Default Gateway]
3. Click [Close] to return to the original screen.

MEMO

- For information on how to set up a network, refer to [Changing the Network Settings](#).

Changing the Network Settings

This section explains how to configure the settings when using the machine with a fixed IP address.

1. Determine the network addresses.

The settings listed here are only an example. The procedure and settings given in this manual do not match every environment. In an environment where the computer being used is connected to multiple network devices and the Internet, inappropriate settings will have a large effect on the entire network. For detailed information about the settings, consult your network administrator.

Determine the IP addresses, subnet mask, and default gateway to connect the computer and this machine to a network.

Procedure

1. Determine the IP addresses.

- Computer: 192.168.0.XXX
- Device: 192.168.0.YYY

"XXX" and "YYY" represent numbers from 1 to 254. Ensure that they are different from the numbers of other network equipment.

2. Determine the subnet mask.

- Computer: 255.255.255.0
- Device: 255.255.255.0

Use the same number for the computer and this machine.

3. Determine the default gateway.

- Computer: 192.168.0.AAA
- Device: 192.168.0.AAA

"AAA" represents numbers from 1 to 254. It may not be necessary to set this number, so check with your network administrator.

2. Change the IP address.

Procedure

1. Click .
2. Click [System Information].
3. Clear the [Obtain IP Address Automatically] check box under [Network].
4. Enter the machine network addresses determined under 1. [Determine the network addresses..](#)

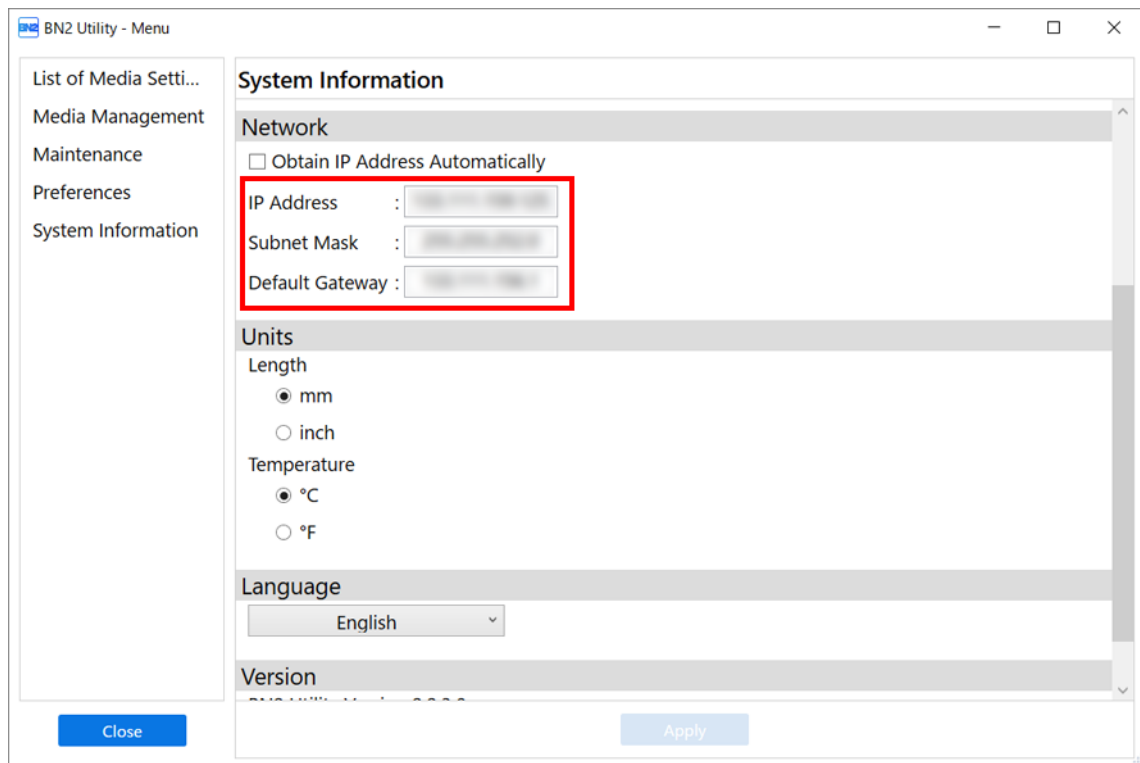

5. Click [Apply].
6. Click [Close] to return to the original screen.
7. Start Roland DG Connect Hub.
8. Click [+], and then enter the IP address determined under 1. [Determine the network addresses.](#) in the address field.
9. Click [Verify], and then click [Apply].
10. Click [OK].

IMPORTANT

If it is not possible to connect the computer and the machine during reinstallation (such as when relocating a machine with a fixed IP address), press the reset button to switch to automatic IP address acquisition.

1. Switch off the sub power.
2. Use a paper clip or something similar to hold down the reset button (Ⓜ) for 5 seconds or longer.

You will hear a short beep when you press the reset button. If you hold down this button for at least 5 seconds from this point, you will hear two short beeps and the machine will reset.

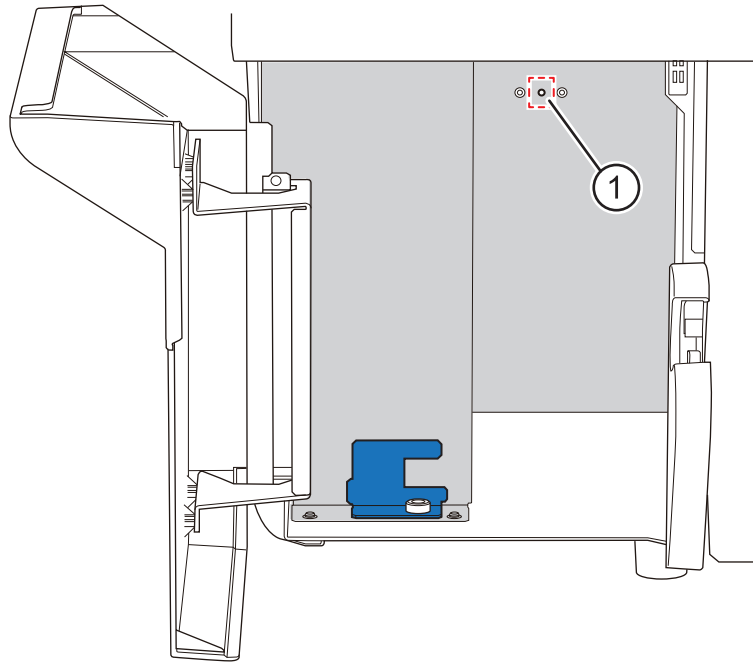

3. Set the computer's network (Windows).

Enter the computer network addresses determined with 1. [Determine the network addresses.](#)(P. 204) for the [IP Address], [Subnet Mask], and [Default Gateway].

MEMO

Operation methods may vary depending on the version and build of the OS.

Procedure

1. Log on to Windows as the [Administrator] or a member of the [Administrators] group.
2. Display the network connections screen.
 - Windows 11 (version: 24H2)
 - a. Click [Start]>[Settings].
 - b. Click [Network & internet]>[Dial-up].
 - c. Click [Network and Sharing Center].
 - d. Click [Ethernet] or [Wi-Fi].
 - Windows 10 (version: 22H2)
 - a. Click [Start]>[Settings]>[Network & Internet].
 - b. Click [Network and Sharing Center].
 - c. Click [Ethernet] or [Wi-Fi].
3. Click [Properties].

If the [User Account Control] dialog box appears, click [Continue].

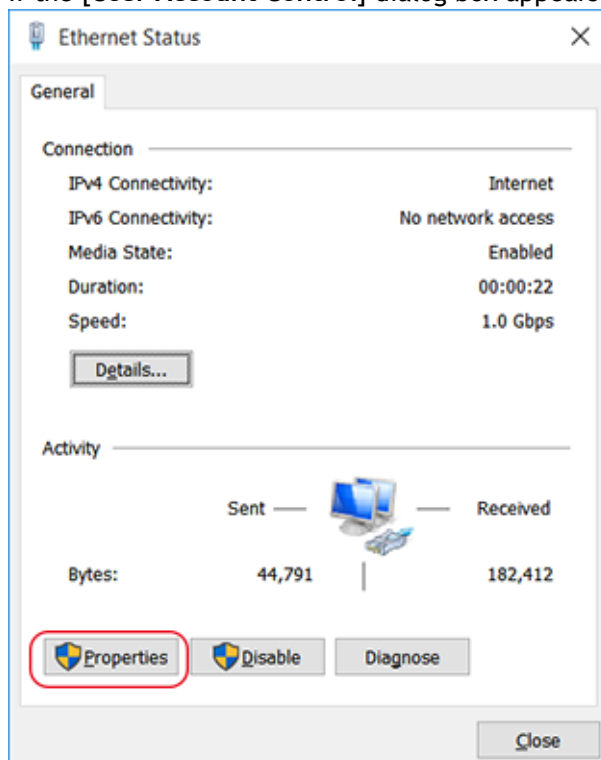

The [Ethernet Properties] or [Wi-Fi Properties] dialog box appears.

4. Select [Internet Protocol Version 4 (TCP/IPv4)], and then click [Properties].

If the [Internet Protocol] check box is clear, select it.

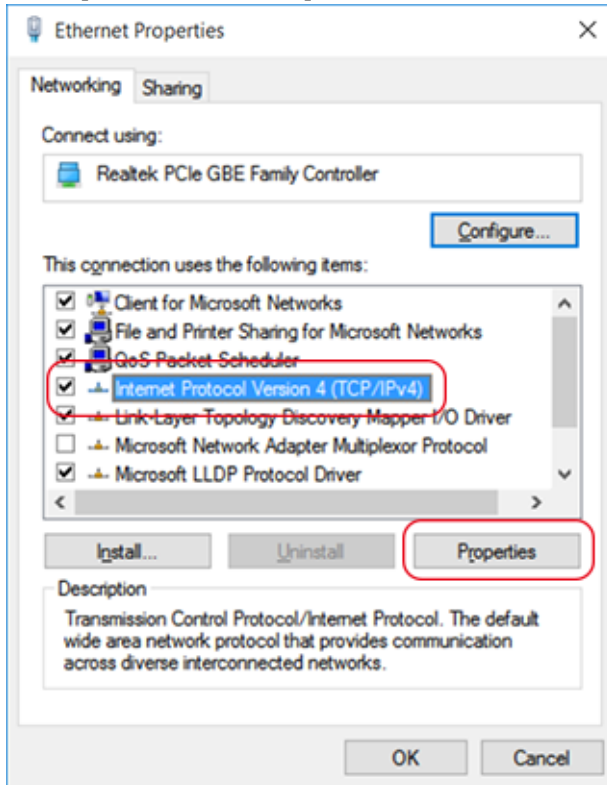

5. Select [Use the following IP address], and then enter the computer network addresses determined under [Determine the network addresses.].

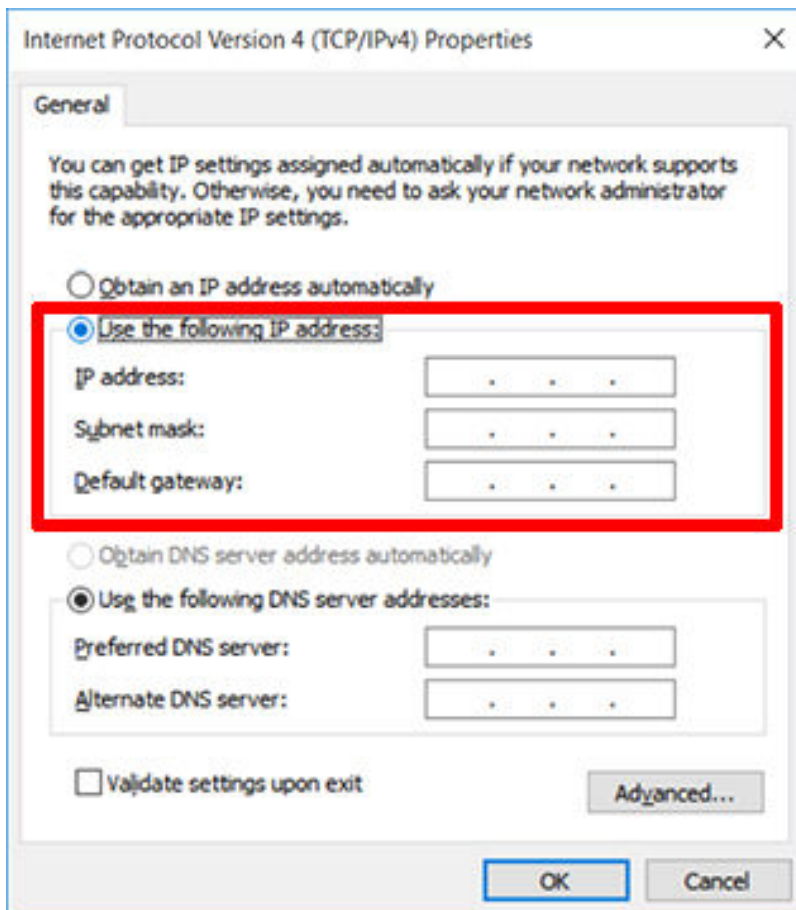

6. Click [OK].
7. Close all the windows opened for the network settings.

4. Set the computer's network (Mac).

Enter the computer network addresses determined with 1. [Determine the network addresses.](#) for the [IP Address], [Subnet Mask], and [Default Gateway].

MEMO

The following operation procedure uses macOS 15.1. Operation methods may vary depending on the version of Mac OS or the build of this OS.

Procedure

1. Log on to the Mac as the "Administrator."
2. From the Apple menu, click [System Settings...].
3. Click [Network]>[Wi-Fi] or the network name (when using Ethernet).
4. Click [Details...].
5. Click [TCP/IP].
6. Select [Manually] for [Configure IPv4].
7. Enter the computer network address that was determined in 1. [Determine the network addresses.](#) (P. 204).
Enter the default gateway in [Router].

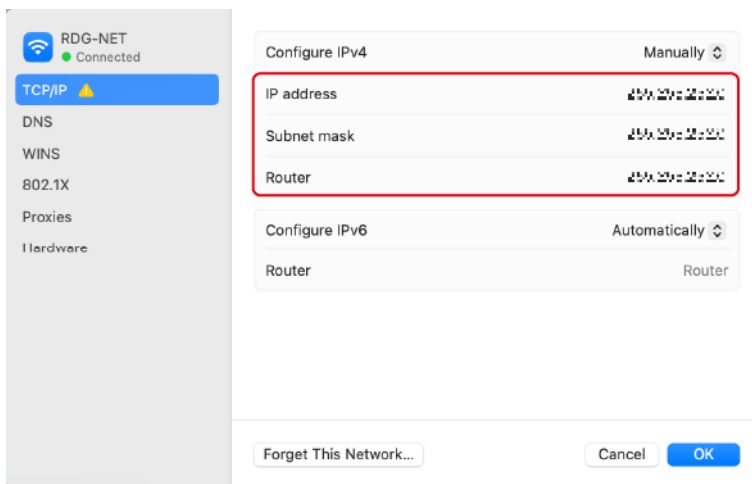

8. Click [OK].

5. Configuring the Settings in VersaWorks

Procedure

1. Open Roland DG Connect Hub.
2. Select the machine to connect to, and then click [Open] next to [VersaWorks 7].
3. Set the machine to connect to VersaWorks.

VersaWorks will automatically search for and register the connectable printers. However, if the search finds zero printers or five or more printers, you will have to register printers manually.

- **When the detected number of printers is one to four**
 - a. Check the detected printer(s) and click [OK].
 - b. When the message [Do you want to install the virtual printer driver?] is displayed, click [Yes].
This message does not indicate the printer driver to use in communication. It indicates the virtual printer driver to use when printing directly from the application.
 - c. When the [User Account Control] window appears, click [Yes] (or [Allow]).
 - d. When the [Add Printer Wizard] window appears, click [Continue].

Registration is complete once the machine information is displayed in the top menu.

- **When no printers or five or more printers are detected**
 - a. Enter the IP address of the printer and click [Verify].
Items such as the [Model Name] and [Firmware Version] are displayed.

MEMO

If the printer is not displayed, check the LAN cable connection status.

- b. Click [Register].

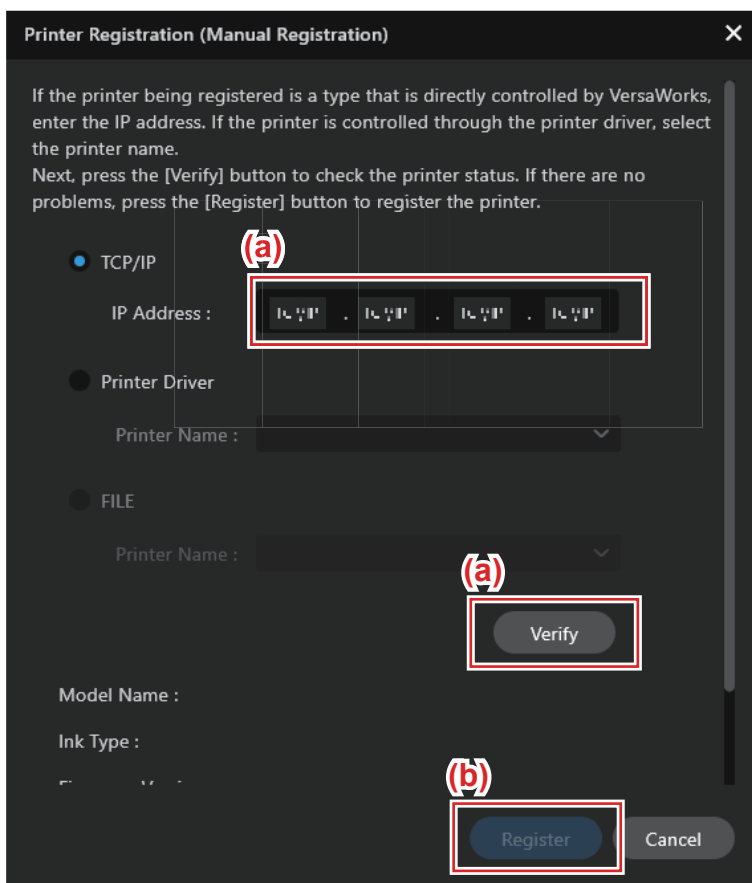

- c. When the message [Do you want to install the virtual printer driver?] is displayed, click [Yes].

This message does not indicate the printer driver to use in communication. It indicates the virtual printer driver to use when printing directly from the application.

- d. When the [User Account Control] window appears, click [Yes] (or [Allow]).
- e. When the [Add Printer Wizard] window appears, click [Continue].
- f. Click [OK].

The information of the connected printer appears in the [Printer List].
Registration is complete once the machine information is displayed in the top menu.

Returning Adjustments to Their State Prior to the Initial Settings

Use the following procedure to return the correction and adjustment values listed below to their values before the initial settings were performed.

IMPORTANT

[Initialize the Adjustment Value Set at the First Startup] is only enabled when the sub power is off.

- Feed Correction
- Media Gap Adjustment
- Multi Sensor Adjustment
- Blade Adjustment
- Print & Cut Position Adjustment

Procedure

1. Switch off the sub power.
2. Click .
3. Click [Execute] under [Preferences]>[Initialize Settings]>[Initialize the Adjustment Value Set at the First Startup].
4. In the confirmation window, click [OK].
5. Click [Close] to return to the original screen.

Resetting All Adjustments to Factory Default Values

This menu returns all settings to the same as their factory defaults.

However, the settings for [Units] are not returned to their factory default values.

Procedure

1. Click .
2. Click [Execute] under [Preferences]>[Initialize Settings]>[Return the Settings to Their Factory Default Values].
3. In the confirmation window, click [OK].
4. Click [Close] to return to the original screen.

Maintenance

Introduction

Important Notes on Handling and Use	216
Printer Unit.....	216
Ink Cartridges	216
Basic Maintenance Knowledge.....	217
Automatic Maintenance Feature and Notes	217
Types and Timing of Maintenance	217
When Not in Use for a Prolonged Period.....	218

Important Notes on Handling and Use

This machine is a precision device. To ensure the full performance of this machine, be sure to observe the following important points. Failure to observe them may not only result in loss of performance, but may also cause malfunction or breakdown.

Printer Unit

This machine is a precision device.

- Handle the machine carefully, and never subject it to impacts or excessive force.
- Never needlessly put your hand or fingers inside the cover, the ink-cartridge ports, or other internal areas of the machine.

Install in a suitable location.

- Install the machine in a location having the specified temperature and relative humidity.
- Install the machine in a quiet, stable location offering good operating conditions.

The print heads are delicate.

- Never needlessly touch or allow media to scrape them. Failure to handle with care may cause damage.
- The print heads may be damaged if allowed to dry out. The machine prevents desiccation automatically, but improper operation may render this feature inoperative. Operate properly, as specified in this manual.
- Never leave the machine with an ink cartridge removed. Remaining ink in the printer may harden and clog the print heads.
- The print heads are components that wear out. Periodic replacement is required, with the frequency of replacement depending on use.

Unsuitable installation sites

- Locations subject to large fluctuations in temperature or humidity
- Locations subject to shaking or vibration • Locations where the floor is tilted, not level, or unstable
- Dusty locations • Locations exposed to direct sunlight
- Locations near air-conditioning or heating equipment • Locations exposed to water or moving air
- Locations exposed to considerable electrical or magnetic noise or other forms of electromagnetic energy

Ink Cartridges

Ink cartridges come in various types.

- Use a type that is compatible with the printer. Also, be sure to use only genuine items from Roland DG Corporation.

Never subject to impact or attempt to disassemble.

- Never drop the ink cartridges or shake them forcefully. The impact may rupture the internal pouch and cause the ink to leak.
- Never attempt to disassemble.
- Never attempt to refill the ink.
- If ink gets on your hands or clothing, wash it off as soon as possible. Removal may become difficult if you leave such adhered ink untreated.

Storage

- Store ink cartridges unopened in a well-ventilated location at a temperature between 10°C and 40°C (50°F to 104°F).

Basic Maintenance Knowledge

Automatic Maintenance Feature and Notes

This machine has a feature that automatically performs maintenance periodically. This feature performs operations such as ones that prevent the print heads from drying out, so:

- Always keep the main power switched on.
- Do not use the machine with one or more covers open.

Types and Timing of Maintenance

To use this machine under its optimal conditions, it is important to perform the appropriate maintenance at the appropriate times.

Regular Maintenance

These are the maintenance items that are required on a daily basis.

Timing	Category	Item
Before daily operations	Mixing the white ink	Maintenance of Ink Cartridges (White Ink Only)
	Cleaning the nozzle surface	Start-up Cleaning
	Print head check	Print Head Check before Printing
After daily operations	Cleaning the machine	Cleaning the Machine
	Cleaning around the print heads	Daily Shut-down Cleaning
If the discharged fluid disposal message appears	Disposing of discharged fluid	Disposing of Discharged Fluid

Advanced Maintenance

Maintenance that is performed in an emergency. Some of this maintenance consumes a large amount of ink, so thoroughly read the explanation, and then perform the operation at the appropriate point in time.

Timing	Category	Item
If colors are uneven	Ink mixing, ink circulation (white ink only), and ink replacement	Did you shake the ink cartridges before installing them?
When dot drop-out or dot displacement occurs	Checking and cleaning the print heads	Step 1: Performing a Nozzle Drop-out Test
		Step 2: Normal Cleaning Method
		Medium Cleaning
		Powerful Cleaning
	Start-up Cleaning	
When severe dot drop-out occurs	Checking and cleaning the print heads	Handling Severe Dot Drop-out

Replacing Consumable Parts

These items are for replacement of consumable parts. Thoroughly read the explanation, and then perform the operation at the appropriate point in time.

Timing	Category	Item
When a message appears	Replacing the wiper	Replacing the Wiper
	Replacing the felt wiper	Replacing the Felt Wiper
	Replacing the wiper pad	Replacing the Wiper Pad
	Replacing the cap top	Replacing the Cap Top
When a cutting edge becomes dull	Replacing the blade	Replacing the Blade
	Replacing the Separating Knife	Replacing the Separating Knife

When Not in Use for a Prolonged Period

In advance, insert ink cartridges that have a large amount of ink remaining.

If the ink runs out, the machine will not be able to periodically perform automatic maintenance. If the machine is left in this state, the print heads may malfunction. If you know that you will not use the machine for a prolonged period, insert ink cartridges that have a large amount of ink remaining.

Replace the drain pack in advance of prolonged periods of disuse.

If you know that you will not use the machine for a prolonged period, replace the drain pack. For information about purchasing drain packs, contact your authorized dealer.

IMPORTANT

Do not reuse drain packs. Doing so makes it impossible to manage the amount of discharged fluid, which may overflow.

Perform start-up cleaning before performing daily shut-down cleaning in the following situations.

- If the printer will not be used for 24 hours or more after performing daily shut-down cleaning
To prevent dot drop-out and dot displacement, perform start-up cleaning before performing daily shut-down cleaning.
- If the printer is not used for a period longer than one week
Even if you are not using the printer, turn on the sub power once a week and perform start-up cleaning followed by daily shut-down cleaning.

IMPORTANT

If the printer is not used for a period longer than one week, the risk of ink hardening increases.

MEMO

The printer should not go unused for more than a week. To stabilize ink discharge, constantly operate the printer, even if the amount of daily printing has decreased. This constant printer operation leads to improved print quality.

RELATED LINKS

- [P. 228 Disposing of Discharged Fluid](#)
- [P. 221 Start-up Cleaning](#)
- [P. 226 Daily Shut-down Cleaning](#)

Regular Maintenance

Maintenance of Ink Cartridges (White Ink Only)	220
Start-up Cleaning	221
Start-up Cleaning Methods.....	222
Print Head Check before Printing	224
Cleaning the Machine	225
Daily Shut-down Cleaning	226
Daily Shut-down Cleaning Methods	226
Disposing of Discharged Fluid.....	228
About Care and Maintenance of the Print Heads	232

Maintenance of Ink Cartridges (White Ink Only)

The ingredients of white ink have a tendency to separate and settle. Allowing the ink to stand can cause the settled material to harden, resulting in malfunction or other problems.

So that the ink mixes well, periodically shake each ink cartridge 100 times (about 40 seconds) horizontally with a stroke length of around 5 cm (1.97 in.) from each end of the ink cartridge before reinserting it.

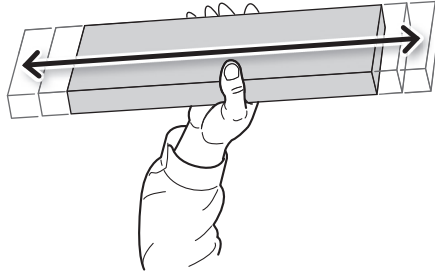

Start-up Cleaning

The print heads move at high speed while discharging ink. To prevent ink solidification and other contaminants from adhering to the nozzle surface of the print heads, clean the nozzle surface of the print heads before the start of daily operations. This cleaning is called "Start-up cleaning."

Before daily operations

Perform start-up cleaning before the start of daily operations.

If a media jam occurs

If the media has jammed, the media may have come into contact with the print head, resulting in a problem with the nozzle surface. Perform start-up cleaning.

If nozzle drop-out, ink drips, or dragging occurs

If any of the following symptoms cannot be corrected using the automatic cleaning function, perform start-up cleaning. Replacing the wipers is also an effective means of improving the symptoms.

[P. 243 Replacing the Wiper](#)

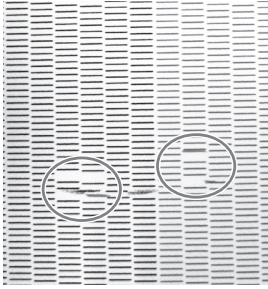
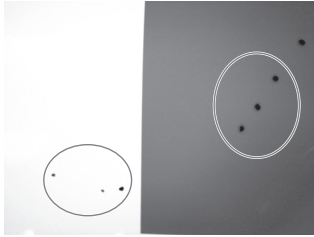
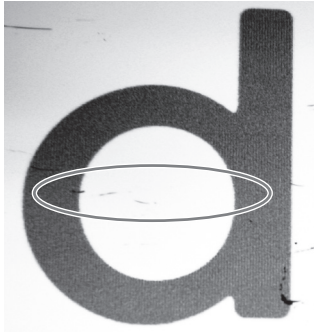
Nozzle drop-out	Ink drips	Dragging dirt
		
Dust or other foreign matter adheres to the print heads and impedes correct ink discharge.	Ink pools in dust or dirt adhered to the print heads, and drips onto the media.	The phenomenon where dirt or dust accumulates on the print heads.

Perform start-up cleaning before performing daily shut-down cleaning in the following situations.

- If the printer will not be used for 24 hours or more after performing daily shut-down cleaning
To prevent dot drop-out and dot displacement, perform start-up cleaning before performing daily shut-down cleaning.
- If the printer is not used for a period longer than one week
Even if you are not using the printer, turn on the sub power once a week and perform start-up cleaning followed by daily shut-down cleaning.

IMPORTANT

If the printer is not used for a period longer than one week, the risk of ink hardening increases.

MEMO

The printer should not go unused for more than a week. To stabilize ink discharge, constantly operate the printer, even if the amount of daily printing has decreased. This constant printer operation leads to improved print quality.

Start-up Cleaning Methods

⚠ WARNING

Be sure to perform operations as specified by the instructions, and never touch any area not specified in the instructions.

Sudden movement of the machine may cause injury.

IMPORTANT

Important notes on this procedure

- Before attempting this operation, remove any media.
- To prevent the print heads from drying out, finish this procedure in 10 minutes or less.
- Never use any implements other than the included cleaning sheet.
- Do not use cleaning liquid other than the included cleaning liquid.
- Be sure to use a new cleaning sheet. Reusing a cleaning sheet will adversely affect the printing results.



If a warning beep sounds during operation

- A warning beep sounds 10 minutes after operation starts. Perform the operation by following the message displayed in the Utility window.

MEMO

- When the cleaning sheet and cleaning liquid used for start-up cleaning run out, purchase them from your authorized dealer.
- The print heads are components that wear out. Periodic replacement is required, with the frequency of replacement depending on use. Contact your authorized dealer.
- Use the following link to view a reference video for this procedure. We recommend that you view this video to understand the overall flow of work.

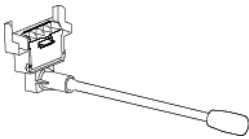
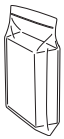
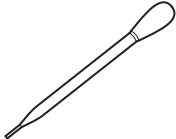
<https://vimeo.com/1084879988/ef435ce499>

Required items			
			
Head nozzle refresher	Cleaning sheets	Dropper	S-PG2-CL cleaning liquid

Procedure

1. Remove any media.
2. Click  [Cleaning].
3. Click [Execute] under [Start-up cleaning].

MEMO

The procedure for performing start-up cleaning appears in the Utility window. Carefully read the on-screen instructions and carry out the work.

4. When cleaning finishes, click [Close].

- The previous window will be displayed.

Print Head Check before Printing

Do a nozzle drop-out test before printing, and if dot drop-out or dot displacement is present, perform cleaning.

In addition, each day before printing, be sure to carry out the following operations.

- White ink mixing: [Maintenance of Ink Cartridges \(White Ink Only\)\(P. 220\)](#)
- Start-up cleaning: [Start-up Cleaning\(P. 221\)](#)

For information on how to perform a nozzle drop-out test, refer to [Step 1: Performing a Nozzle Drop-out Test\(P. 95\)](#).

Cleaning the Machine

⚠ CAUTION

Before attempting cleaning, switch off the sub power and wait until the platen and dryer cool (approximately 30 minutes).

Sudden movement of the machine may cause injury, or hot components may cause burns.

⚠ WARNING

Never use gasoline, alcohol, thinner, or any other flammable material.

Doing so may cause a fire.

Wipe away any ink or grime on the media path and other areas as part of the daily cleaning procedure. Pinch rollers, grit rollers, the platen, and the apron are particularly prone to the buildup of grime. Wipe away any buildup of ink or grime on the media path. Clean by wiping with a cloth moistened by neutral detergent diluted with water then wrung dry.

MEMO

- This machine is a precision device and is sensitive to dust and dirt. Perform cleaning on a daily basis.
- Never attempt to oil or lubricate the machine.

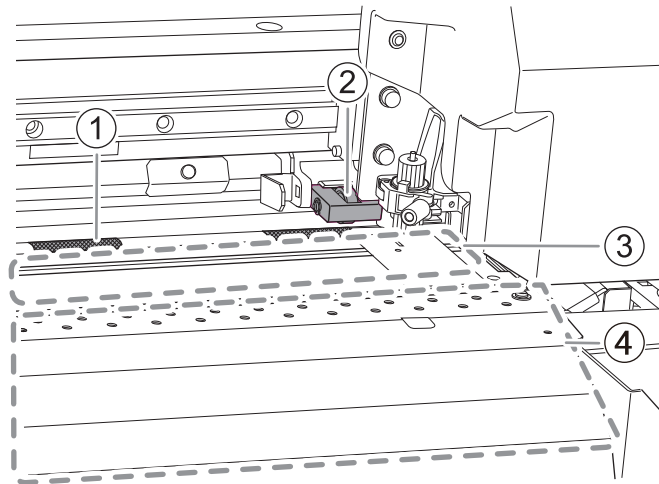

①	Grit roller	Remove buildup of media scraps and other material using a brush. Never use a metal brush.
②	Pinch roller	Periodically wipe away any grime. Failure to clean this part properly may result in the transfer of grime to the surface of media.
③	Platen	Wipe away any buildup of ink or grime on the media path.
④	Apron	

Daily Shut-down Cleaning

Perform start-up cleaning before performing daily shut-down cleaning in the following situations.

- If the printer will not be used for 24 hours or more after performing daily shut-down cleaning
To prevent dot drop-out and dot displacement, perform start-up cleaning before performing daily shut-down cleaning.
- If the printer is not used for a period longer than one week
Even if you are not using the printer, turn on the sub power once a week and perform start-up cleaning followed by daily shut-down cleaning.

IMPORTANT

If the printer is not used for a period longer than one week, the risk of ink hardening increases.

MEMO

The printer should not go unused for more than a week. To stabilize ink discharge, constantly operate the printer, even if the amount of daily printing has decreased. This constant printer operation leads to improved print quality.

Daily Shut-down Cleaning Methods

⚠ WARNING

Be sure to perform operations as specified by the instructions, and never touch any area not specified in the instructions.

Sudden movement of the machine may cause injury.



IMPORTANT

Important notes on this procedure

- Before attempting this operation, remove any media.
- To prevent the heads from drying out, finish this procedure in 30 minutes or less. An alarm sounds after 30 minutes.
- Never use any implements other than the included cleaning sticks. Cotton swabs or other lint-producing items may damage the heads.
- Use one cleaning stick per cleaning session, and then discard the stick after use. Reusing cleaning sticks may reduce print quality.
- Do not put a cleaning stick that has been used for cleaning into the cleaning liquid. Doing so will deteriorate the cleaning liquid.
- Never rub the nozzle surface of the heads.
- Stroke the sponges very gently, applying as little pressure as possible. Never rub, scrape, or crush them.

When a warning beep sounds during cleaning

To prevent the print heads from drying out, an alarm sounds about 30 minutes after the start of the operation. Perform the operation by following the message displayed in the Utility window.

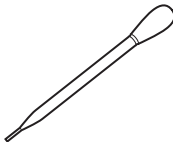
Required items		
		
Cleaning stick	S-PG2-CL cleaning liquid	Dropper

MEMO

- When the cleaning stick and cleaning liquid used for daily shut-down cleaning run out, purchase them from your authorized dealer.
- The print heads are components that wear out. Periodic replacement is required, with the frequency of replacement depending on use. Contact your authorized dealer.
- Use the following link to view a reference video for this procedure. We recommend that you view this video to understand the overall flow of work.
<https://vimeo.com/924895928/ae90f6000e>

Procedure

1. Remove any media.
2. Click  [Cleaning].
3. Click [Execute] under [Daily shut down cleaning].

MEMO

The procedure for performing daily shut-down cleaning appears in the Utility window. Carefully read the on-screen instructions and carry out the work.

4. When cleaning finishes, click [Close].
The display returns to the original window.

Disposing of Discharged Fluid

If the drain pack is full of discharged fluid, the following message prompting you to replace the drain pack will appear in the Utility window.

BN2 Utility - Error



Replace the drain pack.
Be sure to put on protective eyewear and gloves before performing this work.

Open the lower-right cover, and then remove the drain cartridge.

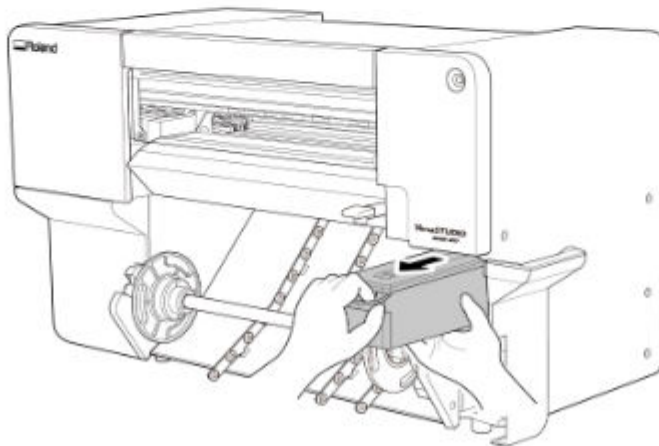

Prepare a replacement drain pack or replace the existing drain pack by following the displayed message.

⚠ CAUTION

Before you remove the drain cartridge, wait for a message to be displayed in Utility.

Failing to follow this procedure may cause discharged fluid to flow out of the tube and spill, soiling your hands or the floor.

Wipe off any ink that has adhered around the hole in the lid of the drain cartridge.

Also, if you know that you will not use the machine for a prolonged period, follow the procedure below to replace the drain pack.

⚠ WARNING

Never place the drain cartridge or ink near an open flame.

Doing so may cause a fire.

MEMO

Use the following link to view a reference video for this procedure. We recommend that you view this video to understand the overall flow of work.

<https://vimeo.com/1003477050/f49ec2919c>

The BN2-20/20A is shown in this video, but the work and operation procedures are the same for this machine.

Procedure

1. Open the lower-right cover.

2. Remove the drain cartridge.

Pull the drain cartridge out until you can support its base with your hand. Then, remove this cartridge by holding its handle and its base.

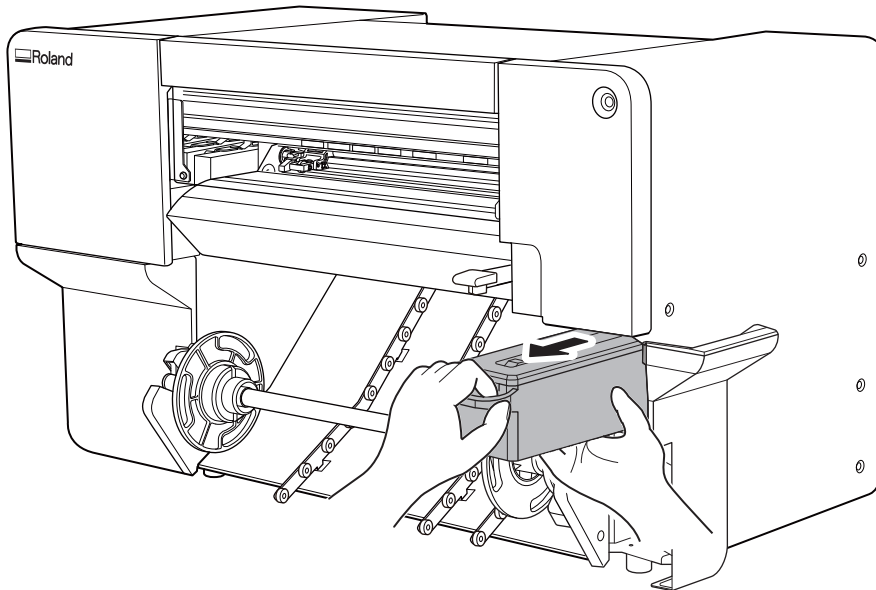

IMPORTANT

Do not drop the drain cartridge or subject it to impacts. Damage to the protrusion on the drain cartridge will make it impossible for the machine to recognize the drain cartridge, resulting in a drain cartridge error.

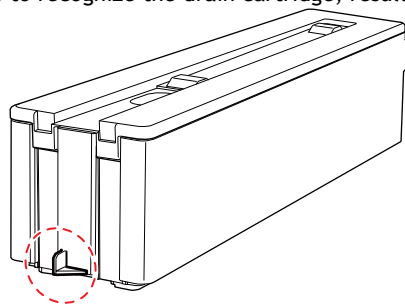

3. Release the hooks in two locations to unlock the drain cartridge lid, and then open it.

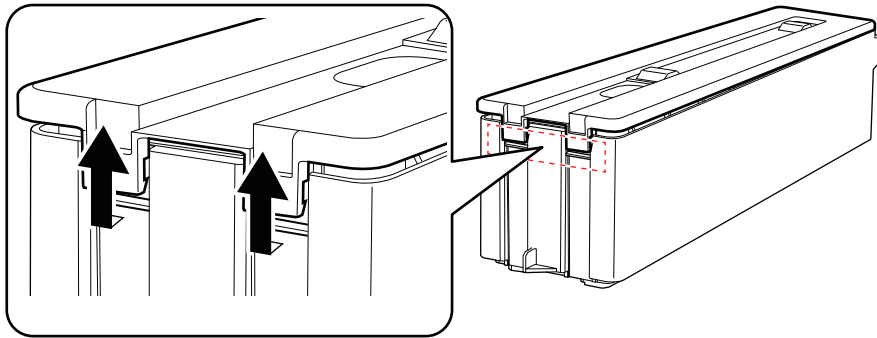

4. Lift up the flap of the drain pack to remove it from the drain cartridge.

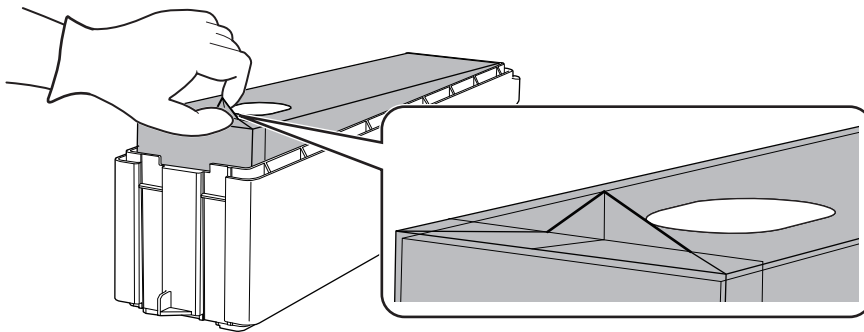

5. Insert a new drain pack into the drain cartridge.
Insert the drain pack so its hole is on the opposite side to the handle of the drain cartridge.

IMPORTANT

Do not reuse drain packs.

Doing so makes it impossible to manage the amount of discharged fluid, which may overflow.

IMPORTANT

Do not touch the drain pack's hole. Ink may adhere to whatever touches this hole.

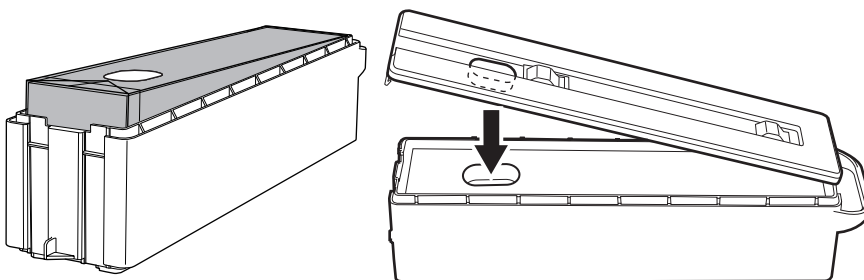

6. Close the drain cartridge lid.

Align the hole in the lid of the drain cartridge and the drain pack's hole, and then close the lid from the handle side. If the lid is not flush with the cartridge, gently press down around the circumference of the lid to fit it into the cartridge.

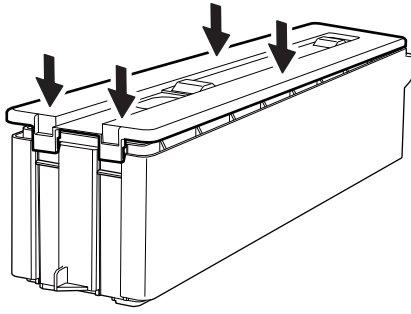

7. Insert the drain cartridge into the machine.

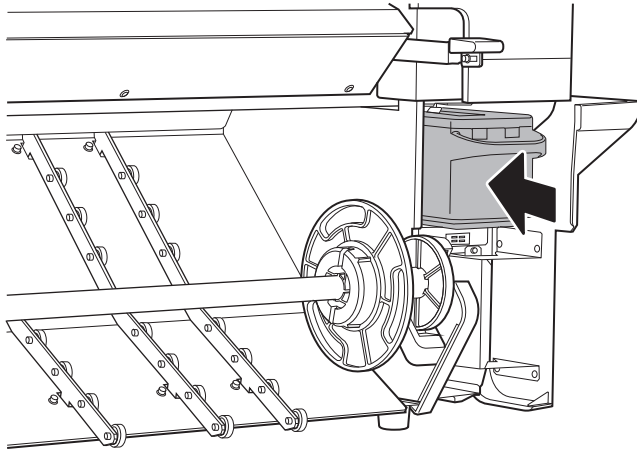

8. Close the lower-right cover.

9. If a window asking you to confirm whether you replaced the drain pack appears, click [Yes] to close the message.

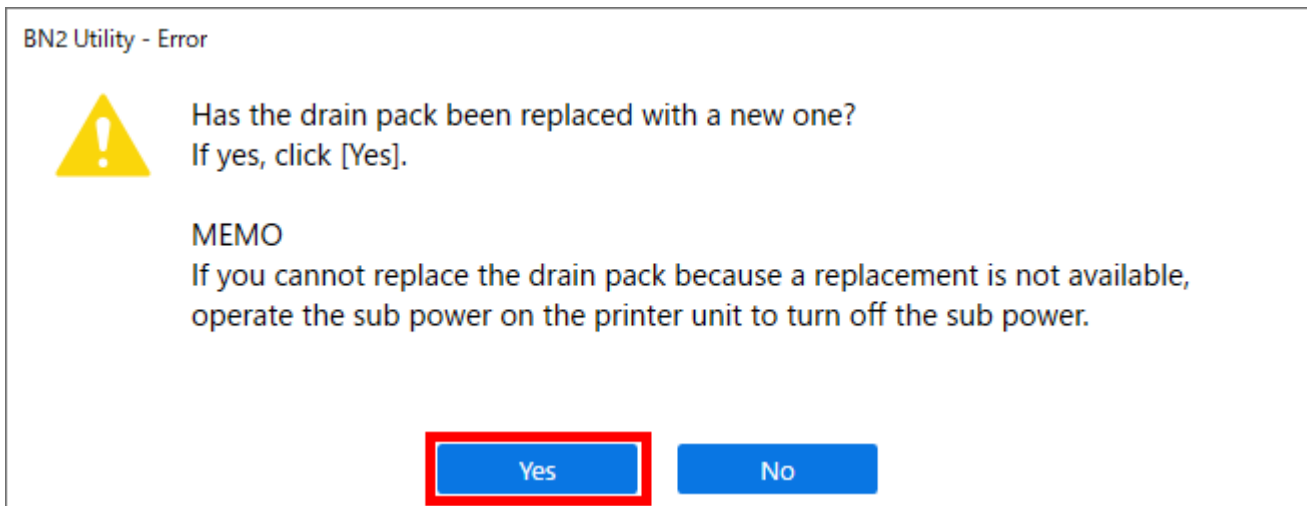

IMPORTANT

Dispose of discharged fluid properly, in accordance with the laws in effect in your locale. Discharged fluid is flammable and contains toxic ingredients. Never attempt to incinerate discharged fluid or discard it with ordinary trash. Also, do not dispose of it in sewer systems, rivers, or streams. Doing so may have an adverse impact on the environment.

For information about purchasing drain packs and drain cartridges, contact your authorized dealer.

About Care and Maintenance of the Print Heads

Care of the print heads is essential to ensure optimal printing at all times. There are maintenance tasks that should be performed daily and those that should be performed periodically.

Daily Care and Maintenance

We recommend that you perform a print head check before day-to-day operation.

[P. 95 Performing a Nozzle Drop-out Test](#)

Periodic Care and Maintenance

To maintain stable output at all times, we recommend that you periodically clean the print heads.

* The print heads are components that wear out. Periodic replacement is required, with the frequency of replacement depending on use. Contact your authorized dealer.

[P. 234 Periodical Cleaning Maintenance](#)

Advanced Maintenance

- Periodical Cleaning Maintenance..... 234
 - Medium Cleaning 234
 - Powerful Cleaning 236
- Handling Severe Dot Drop-out 238

Periodical Cleaning Maintenance

Medium Cleaning

When problems such as dot drop-out and dot displacement are not resolved by normal cleaning, perform the more forceful [Medium Cleaning] to remove clogging from the print heads.

MEMO

- Medium cleaning consumes more ink than normal cleaning. Because the print heads are prone to damage if cleaned too frequently, do not perform cleaning more than necessary.
- If the media has already been set up, the [After cleaning, perform a printing test] menu appears. When this is turned on, a printing test is performed after cleaning.

Procedure

1. Set up the media.
2. Click  [Cleaning].
3. Select [Medium Cleaning] under [Head Cleaning], and then click [Execute].
Medium cleaning starts.

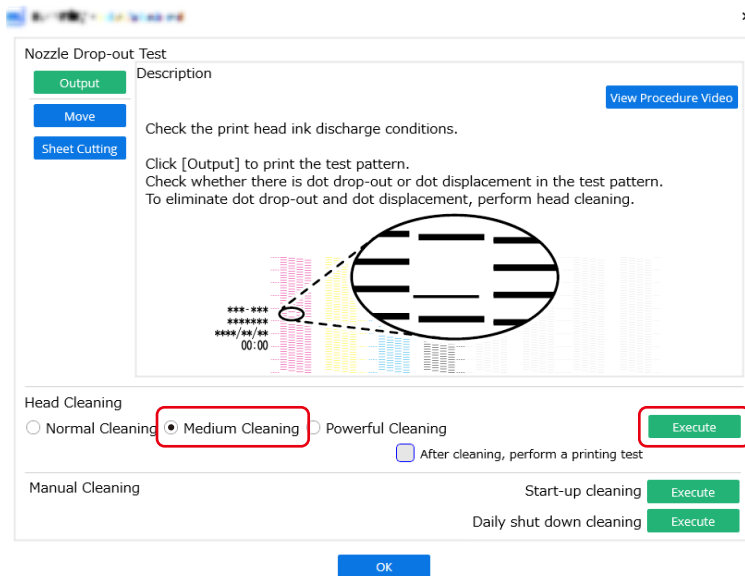

4. When cleaning finishes, click [Output].
Printing of the test pattern starts.

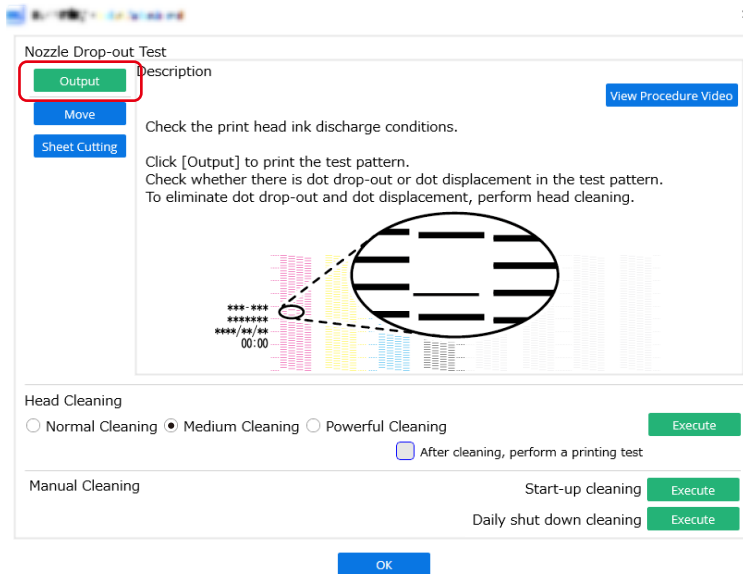

5. Check whether there is dot drop-out or dot displacement in the test pattern. Missing blocks indicate dot drop-out. Collapsed or inclined blocks indicate dot displacement.



MEMO

- If the problem persists, try performing medium cleaning again.
- If problems such as dot drop-out and dot displacement persist even after you have performed medium cleaning two or three times, perform the more forceful **[Powerful Cleaning]**.
- This cleaning can be effective when carried out periodically, according to the frequency of use.

6. If you have opened the front cover, close it.
If no dot drop-out or dot displacement occurs, preparations for output are finished.
7. Click [Close] to return to the original window.

RELATED LINKS

- [P. 236 Powerful Cleaning](#)

Powerful Cleaning

When problems such as dot drop-out and dot displacement are not resolved by medium cleaning, perform the more forceful [Powerful Cleaning] to remove clogging from the print heads.

MEMO

- Powerful cleaning consumes more ink than medium cleaning. Because the print heads are prone to damage if cleaned too frequently, do not perform cleaning more than necessary.
- If the media has already been set up, the [After cleaning, perform a printing test] menu appears. When this is turned on, a printing test is performed after cleaning.

Procedure

1. Set up the media.
2. Click  [Cleaning].
3. Select [Powerful Cleaning] under [Head Cleaning], and then click [Execute].
Powerful cleaning will start.

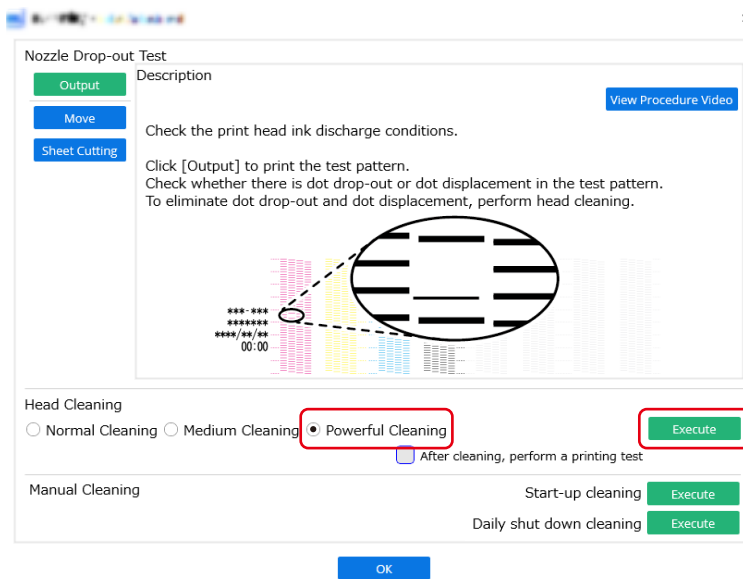

4. When cleaning finishes, click [Output].
Printing of the test pattern starts.

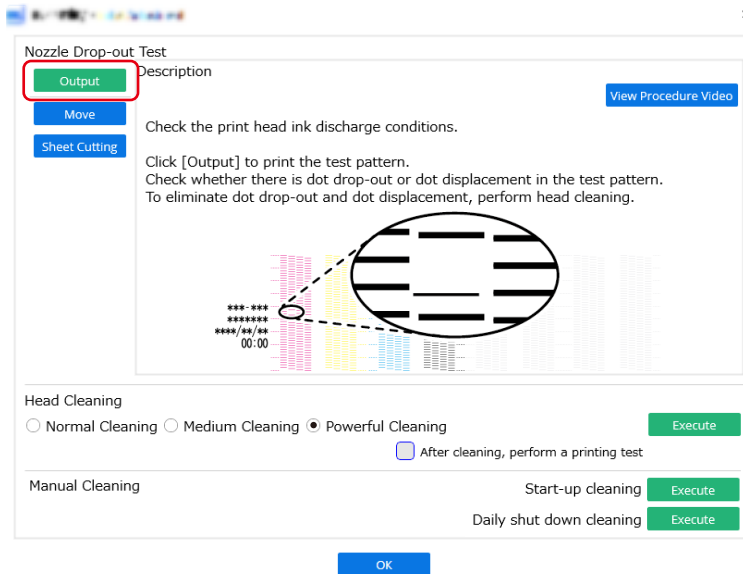

5. Check whether there is dot drop-out or dot displacement in the test pattern.
Missing blocks indicate dot drop-out. Collapsed or inclined blocks indicate dot displacement.



MEMO

- If the problem persists, try performing powerful cleaning again.
- If problems such as dot drop-out and dot displacement persist even after you have performed powerful cleaning several times, perform [Start-up cleaning].
- This cleaning can be effective when carried out periodically, according to the frequency of use.

6. If you have opened the front cover, close it.
If no dot drop-out or dot displacement occurs, preparations for output are finished.
7. Click [Close] to return to the original window.

RELATED LINKS

- [P. 221 Start-up Cleaning](#)

Handling Severe Dot Drop-out

If dot drop-out occurs in multiple locations within a row, cleaning is required. Perform cleaning according to the following procedure. Because there are cleaning procedures that use a lot of ink, perform a Nozzle Drop-out Test after each procedure to check whether the situation has improved.

Procedure

1. Perform [Normal Cleaning].
2. Perform [Medium Cleaning].
3. Perform [Powerful Cleaning].
4. Perform [Light Choke Cleaning].
 - (1) Click .
 - (2) Click [Execute] under [Maintenance]>[Ink]>[Light Choke Cleaning].
 - (3) Perform [Nozzle Drop-out Test].

RELATED LINKS

- [P. 95 Performing a Nozzle Drop-out Test](#)
- [P. 97 Normal Cleaning Method](#)
- [P. 234 Medium Cleaning](#)
- [P. 236 Powerful Cleaning](#)
- [P. 22 Maintenance](#)

Replacing Consumable Parts

Replacing Ink Cartridges	240
Out-of-ink Warnings	240
Replacing Ink Cartridges	241
Replacing Parts for Maintenance	243
Replacing the Wiper	243
Replacing the Felt Wiper	245
Replacing the Wiper Pad	246
Replacing the Blade	248
Replacing the Separating Knife	250
Replacing the Cap Top	252

Replacing Ink Cartridges

Out-of-ink Warnings

When an ink pouch runs out, printing pauses and [Ink Cartridge Error] appears.

[Ink has run out.] is displayed for ink that has run out. Check the Utility window, and then replace the empty ink.

- Wh: White
- C: Cyan
- M: Magenta
- [Y] Yellow
- K: Black

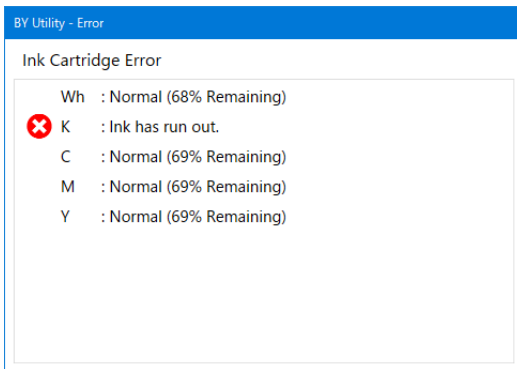

IMPORTANT

Never reuse an ink cartridge for which the machine shows a sign indicating no ink.

Occasionally the machine will show a sign indicating no ink even if there is a small amount of ink remaining in the cartridge, but nevertheless do not use it. Such an ink cartridge is in a state where drawing ink from it is impossible. Using it in such a state may force air into the ink path and cause malfunctions.

Replacing Ink Cartridges

⚠ WARNING

Never store ink, cleaning liquid, or discharged fluid in any of the following locations.

- Any location exposed to open flame
- Any location where high temperature may occur
- Near bleach or any other such oxidizing agent or explosive material
- Any location within the reach of children

Fire may be a danger. Accidental ingestion by children may pose a health hazard.

IMPORTANT

Important notes on replacing cartridges

- Replace the cartridge with an item of identical type and color.
 - Insert the cartridge so that the side with the arrow faces up.
 - Insert and remove cartridges slowly, one at a time.
 - Insert the cartridge firmly, as far as it will go.
- Never mix different types of items.
- Never leave the machine with an ink cartridge removed. The print heads may become clogged.
- Never insert or remove a partially used ink cartridge with undue force.

IMPORTANT

Never reuse an ink cartridge for which the machine shows a sign indicating no ink.

Occasionally the machine will show a sign indicating no ink even if there is a small amount of ink remaining in the cartridge, but nevertheless do not use it. Such an ink cartridge is in a state where drawing ink from it is impossible. Using it in such a state may force air into the ink path and cause malfunctions.

Procedure

1. Open the left cover.
2. Pull out the empty ink cartridge.
3. Gently shake the new ink cartridge.

During storage, the ink components may have precipitated. The precipitation of the ingredients in the ink disables printing in normal color. So that the ink mixes well, shake each ink cartridge 100 times (about 40 seconds) horizontally with a stroke length of around 5 cm (1.97 in.) from each end of the ink cartridge before inserting it.

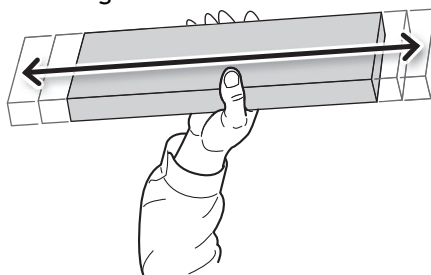

4. Insert the ink cartridge into its ink slot.

Replacing Ink Cartridges

Orient the ink cartridge so the arrow is on top, and then insert the ink cartridge as far as it will go.

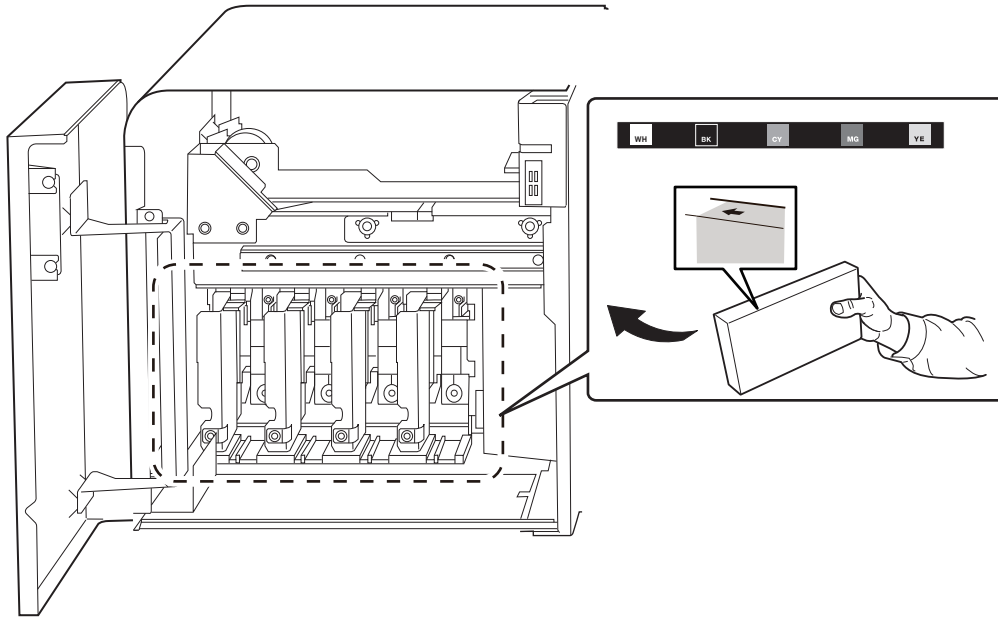

5. Close the left cover.

Replacing Parts for Maintenance

Replacing the Wiper

The wiper is a component that you use when cleaning the print heads.

When it is time to replace the wiper, the message [The time for wiper replacement has arrived.] appears. In this situation, replace the wiper.

For information about purchasing wipers, contact your authorized dealer.

⚠ WARNING

Be sure to perform operations as specified by the instructions, and never touch any area not specified in the instructions.

Sudden movement of the machine may cause injury.

IMPORTANT

When the warning alarm sounds during wiper replacement

To prevent the print heads from drying out, an alarm sounds about 30 minutes after the start of the operation. Perform the operation by following the message displayed in the Utility window.

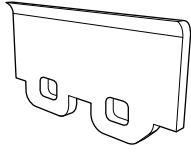
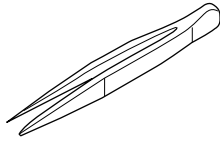
Required items	
	
Wiper	Tweezers

MEMO

Use the following link to view a reference video for this procedure. We recommend that you view this video to understand the overall flow of work.

<https://vimeo.com/1003476606/3c45a51aa4>

The BN2-20/20A is shown in this video, but the work and operation procedures are the same for this machine.

Procedure

1. When the message [The time for wiper replacement has arrived.] appears, click [OK].
2. Remove any media.
3. Click  to display the messages.
4. Click [The time for wiper replacement has arrived.].
The [Wiper Replacement] window appears.
5. Click [OK].
The print-head carriage moves to a location where wiper replacement is possible.

6. When the print-head carriage stops, open the right cover.
7. Follow the on-screen instructions to replace the wiper.
8. When the operation is complete, close the right cover.
9. Click [Finish].
The print-head carriage returns to its original position.

Replacing the Felt Wiper

The felt wiper is a component that is used for cleaning the print heads.

When it is time to replace the felt wiper, the message [The time for felt wiper replacement has arrived.] appears. In this situation, replace the felt wiper.

For information about purchasing felt wipers, contact your authorized dealer.

⚠ WARNING

Be sure to perform operations as specified by the instructions, and never touch any area not specified in the instructions.

Sudden movement of the machine may cause injury.

IMPORTANT

When the warning alarm sounds during felt wiper replacement

To prevent the print heads from drying out, an alarm sounds about 30 minutes after the start of the operation. Perform the operation by following the message displayed in the Utility window.

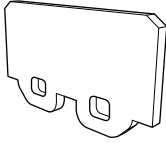
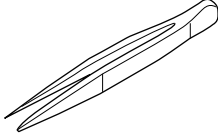
Required items	
	
Felt wiper	Tweezers

MEMO

Use the following link to view a reference video for this procedure. We recommend that you view this video to understand the overall flow of work.

<https://vimeo.com/1003475818/8b2a3f3955>

The BN2-20/20A is shown in this video, but the work and operation procedures are the same for this machine.

Procedure

1. When the message [The time for felt wiper replacement has arrived.] appears, click [OK].
2. Remove any media.
3. Click  to display the messages.
4. Click [The time for felt wiper replacement has arrived.].
The [Felt Wiper Replacement] window appears.
5. Click [OK].
The print-head carriage moves to a location where felt wiper replacement is possible.
6. When the print-head carriage stops, open the right cover.

7. Follow the on-screen instructions to replace the felt wiper.
8. When the operation is complete, close the right cover.
9. Click [Finish].
The print-head carriage returns to its original position.

Replacing the Wiper Pad

The wiper pad catches ink when the head surface is cleaned with the wiper.

When it is time to replace the wiper pad, the message [The time for wiper pad replacement has arrived.] appears. In this situation, replace the wiper pad.

For information about purchasing wiper pads, contact your authorized dealer.

⚠ WARNING

Be sure to perform operations as specified by the instructions, and never touch any area not specified in the instructions.

Sudden movement of the machine may cause injury.

IMPORTANT

When the warning alarm sounds during wiper pad replacement

To prevent the print heads from drying out, an alarm sounds about 30 minutes after the start of the operation. Perform the operation by following the message displayed in the Utility window.

MEMO

Use the following link to view a reference video for this procedure. We recommend that you view this video to understand the overall flow of work. <https://vimeo.com/1003477176/9fea8d956b>

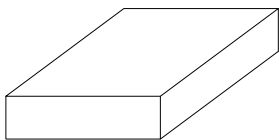
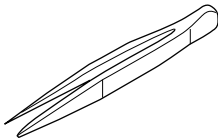
Required items	
	
Wiper pad	Tweezers

Procedure

1. When the message [The time for wiper pad replacement has arrived.] appears, click [OK].
2. Remove any media.
3. Click  to display the messages.
4. Click [The time for wiper pad replacement has arrived.].
The [Wiper Pad Replacement] window appears.

5. Click [OK].
The print-head carriage moves to a location where replacement work is possible.
6. When the print-head carriage stops, open the right cover.
7. Follow the on-screen instructions to replace the wiper pad.
8. When the operation is complete, close the right cover.
9. Click [Finish].
The print-head carriage returns to its original position.

Replacing the Blade

If the blade becomes dull, if the edge of the blade is chipped, or if the cutting quality is lowered, replace the blade with a new blade.

⚠ WARNING

Be sure to perform operations as specified by the instructions, and never touch any area not specified in the instructions.

Sudden movement of the machine may cause injury.

⚠ CAUTION

Never touch the tip of the knife.

Doing so may result in injury. The cutting performance of the blade will also be impaired.

IMPORTANT

When the warning alarm sounds during blade replacement

To prevent the print heads from drying out, an alarm sounds a set amount of time after the start of the operation. Perform the operation by following the message displayed in the Utility window.

Required item

Replacement blade

MEMO

Use the following link to view a reference video for this procedure. We recommend that you view this video to understand the overall flow of work.

<https://vimeo.com/1003472243/1889a633f0>

The BN2-20/20A is shown in this video, but the work and operation procedures are the same for this machine.

Procedure

1. Remove any media.
2. Click .
3. Click [Execute] under [Maintenance]>[Parts Replacement]>[Blade].
The [Blade Replacement] window appears, and the print-head carriage moves to a location where blade replacement is possible.
4. When the print-head carriage stops, open the front cover.
5. Follow the on-screen instructions to replace the blade.
6. When the blade replacement finishes, close the front cover and click [Finish].

7. Click [Close] to return to the original screen.

RELATED LINKS

- [P. 157 Accurately Adjusting the Cutting Settings](#)

Replacing the Separating Knife

If the separating knife becomes dull or if the edge of the separating knife is chipped, replace the separating knife with a new separating knife.

⚠ WARNING

Be sure to perform operations as specified by the instructions, and never touch any area not specified in the instructions.

Sudden movement of the machine may cause injury.

⚠ CAUTION

Do not touch the tip of the separating knife.

Doing so may result in injury.

IMPORTANT

When the warning alarm sounds during separating knife replacement

To prevent the print heads from drying out, an alarm sounds a set amount of time after the start of the operation. Perform the operation by following the message displayed in the Utility window.

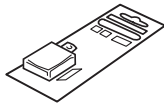
Required item

Replacement blades for separating knife

MEMO

Use the following link to view a reference video for this procedure. We recommend that you view this video to understand the overall flow of work.

<https://vimeo.com/1003476274/1b5691fdca>

The BN2-20/20A is shown in this video, but the work and operation procedures are the same for this machine.

Procedure

1. Remove any media.
2. Click .
3. Click [Execute] under [Maintenance]>[Parts Replacement]>[Separating Knife].
The [Separating Knife Replacement] window appears, and the print-head carriage moves to a location where separating knife replacement is possible.
4. When the print-head carriage stops, open the front cover.
5. Follow the on-screen instructions to replace the separating knife.
6. When the separating knife replacement is finished, close the front cover and click [Finish].

7. Click [Close] to return to the original screen.

Replacing the Cap Top

The cap top is a protective part that prevents the print heads from drying out. For information about purchasing cap tops, contact your authorized dealer.

⚠ WARNING

Be sure to perform operations as specified by the instructions, and never touch any area not specified in the instructions.

Sudden movement of the machine may cause injury.

IMPORTANT

If a warning beep sounds during the procedure

This operation consists of three procedures: replacement, cleaning, and confirmation. To prevent the print heads from drying out, a warning beep sounds about 30 minutes after the start of replacement and about 5 minutes after the start of post-cleaning confirmation. If this beep sounds, perform operations by following the message displayed in the Utility window.

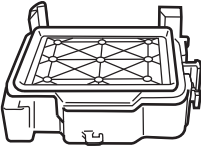
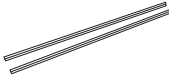
Required items	
	
Cap Top	Twist Ties (2) ^{*1}

*1 Use two of the three twist ties included with the replacement cap top. The remaining twist tie is a spare.

MEMO

Use the following link to view a reference video for this procedure. We recommend that you view this video to understand the overall flow of work.

<https://youtu.be/7dUVH9Dm1Xk>

The BN2-20/20A is shown in this video, but the work and operation procedures are the same for this machine.

Procedure

1. Click .
2. Click [Execute] under [Maintenance]>[Parts Replacement]>[Cap Top].
3. Carefully read the explanation on the [Cap Top Replacement] window, and then click [Next].
The print-head carriage moves to a location where cap top replacement is possible.
4. When the print-head carriage stops, open the front and right covers.
5. Follow the on-screen instructions to replace the cap top.
6. When the cap top replacement is finished, close all the covers and click [Next].
The print-head carriage returns to the original position, and then head cleaning starts. When head cleaning finishes, proceed to the next step.

7. Open the right cover, and then check that there is ink on the cap top.
8. Close the right cover, and then click [Finish].
9. Click [Close] to return to the original screen.

Troubleshooting Methods

Output Quality Problems

Printed results are coarse or contain horizontal stripes.....	256
Do the Print Heads Show Nozzle Drop-Out?	256
Have you carried out [Feed Correction] ?	256
Have you carried out [Media Gap Adjustment] ?	256
Is the temperature of the room too low?.....	257
Is the printer installed in a level and stable location?	257
Is the media heating system at a suitable temperature?	257
Is the printer installed in a location out of direct sunlight?.....	257
Is the media loaded and set up correctly?	257
Colors are unstable or uneven.....	258
Did you shake the ink cartridges before installing them?.....	258
Is the media wrinkled?	258
Was printing paused partway through?	258
Is the printer installed in a level and stable location?	259
Is the printer being used in a location subject to severe changes in the operating environment?	259
Is the media loaded and set up correctly?	259
The media becomes soiled when printed	260
Are the print heads dirty?.....	260
Are the pinch rollers or the media clamps dirty?	260
Cutting is misaligned or skewed.....	261
Is the media loaded and set up correctly?	261
Are the settings for the cutting conditions appropriate?	261
Is the length of output too long?.....	261
Are you using media that exhibits large expansion and contraction?.....	261
Is the setting for the [Cutting Distance Correction] menu item (under [List of Media Settings]) correct?	261
Have you corrected the misalignment of printing and cutting?.....	262
Is the cutting tool installed appropriately?	262
Is the blade worn?.....	262
Is there any buildup of pieces of media or dust inside the blade holder?.....	262
The printed surface is damaged when cutting	263
Does the tip of the blade holder cap scrape the printed surface?	263

Printed results are coarse or contain horizontal stripes

Do the Print Heads Show Nozzle Drop-Out?

Carry out a printing test and make sure no nozzle drop-out occurs. If nozzle drop-out is present, perform head cleaning according to the following procedure. Because there are cleaning procedures that use a lot of ink, perform a Nozzle Drop-out Test after each procedure to check whether the situation has improved.

1. Perform **[Normal Cleaning]**.
2. Perform **[Medium Cleaning]**.
3. Perform **[Powerful Cleaning]**.
4. Perform **[Start-up cleaning]**.

MEMO

If severe dot drop-out—such as dot drop-out in multiple locations within a row—occurs, see [Handling Severe Dot Drop-out](#).

RELATED LINKS

- [P. 95 Performing a Nozzle Drop-out Test](#)
- [P. 97 Normal Cleaning Method](#)
- [P. 234 Medium Cleaning](#)
- [P. 236 Powerful Cleaning](#)
- [P. 221 Start-up Cleaning](#)

Have you carried out **[Feed Correction]**?

Large misalignment in the amount of feed of the media may result in printing that seems coarse or contains horizontal bands. It is recommended to carry out **[Feed Correction]** when you change the media type.

RELATED LINKS

- [P. 138 Manual Adjustment: Reducing Horizontal Bands \(Feed Correction\)](#)

Have you carried out **[Media Gap Adjustment]**?

If you are performing bidirectional printing, it is recommended to carry out **[Media Gap Adjustment]** when you change the media type. The optimal adjustment value may vary depending mainly on the thickness of the media.

RELATED LINKS

- [P. 140 Manual Adjustment: Adjusting the Misalignment of the Ink Landing Position \(Media Gap Adjustment\)](#)

Is the temperature of the room too low?

The heater may not warm up sufficiently when the ambient temperature is less than 20°C (68°F). Also, even when the heater warms up, adequate effectiveness may not be apparent if the media is thoroughly chilled. Before printing, allow the media to come to room temperature.

Is the printer installed in a level and stable location?

Never install the machine in a location where it is tilted or where it may wobble or experience vibration. Also make sure that the print heads are not exposed to moving air. These factors may lead to nozzle drop-out or reduced printing quality.

Is the media heating system at a suitable temperature?

If the ink forms lumps or smudges, set the heater to a higher temperature.

Note, however, that a heater temperature that is too high may degrade the media or cause it to wrinkle.

RELATED LINKS

- [P. 149 Setting the Print Heater Temperature](#)
- [P. 151 Setting the Dryer Temperature](#)

Is the printer installed in a location out of direct sunlight?

Never install in a location exposed to direct sunlight.

Is the media loaded and set up correctly?

If the media is not loaded correctly, printing may be adversely affected. Make sure the media is loaded and set up correctly.

RELATED LINKS

- [P. 37 Setup of New Media](#)
- [P. 63 Setup of Registered Media](#)
- [P. 267 Media Feed Problems](#)

Colors are unstable or uneven

Did you shake the ink cartridges before installing them?

Procedure

1. So that the ink mixes well, shake each ink cartridge 100 times (about 40 seconds) horizontally with a stroke length of around 5 cm (1.97 in.) from each end of the ink cartridge before reinserting it.

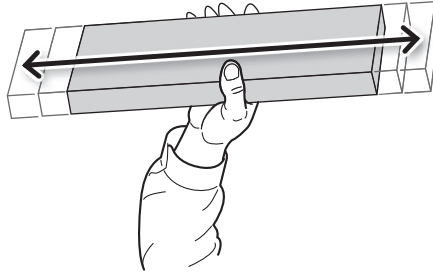

2. Perform the following operations.

- White ink

Perform [Ink Circulation].

If uneven color issues persist even after performing [Ink Circulation], perform [Powerful Cleaning] multiple times.

If uneven color issues persist even after performing [Powerful Cleaning] multiple times, perform [Light Choke Cleaning].

- Ink other than white ink

Perform [Powerful Cleaning].

If uneven color issues persist, perform [Powerful Cleaning] multiple times.

If uneven color issues persist even after performing [Powerful Cleaning] multiple times, perform [Light Choke Cleaning].

RELATED LINKS

- [P. 22 Maintenance](#)
- [P. 86 Preventing Sedimentation in Inks](#)
- [P. 236 Powerful Cleaning](#)

Is the media wrinkled?

If the media is wrinkled and comes loose from the platen, colors may be uneven or the printing quality may suffer.

RELATED LINKS

- [P. 267 Media Feed Problems](#)

Was printing paused partway through?

When printing is paused, the coloring at the seam may be altered when printing resumes. Avoid pausing printing.

Before you perform lengthy printing, check the amount of ink remaining in the ink cartridges. Printing may also pause when data is not sent from the computer quickly enough. We recommend not performing any other tasks with the computer while printing is in progress.

Is the printer installed in a level and stable location?

Never install the machine in a location where it is tilted or where it may wobble or experience vibration. Also, make sure that the print heads are not exposed to circulating air. These factors may lead to nozzle clogging or reduced printing quality.

Is the printer being used in a location subject to severe changes in the operating environment?

Large fluctuations in temperature or humidity while printing is in progress may cause the colors to change partway through the printing. When printing, use the machine in a location where the temperature and humidity are stable.

Is the media loaded and set up correctly?

If the media is not loaded correctly, printing may be adversely affected. Make sure the media is loaded and set up correctly.

RELATED LINKS

- [P. 37 Setup of New Media](#)
- [P. 63 Setup of Registered Media](#)
- [P. 267 Media Feed Problems](#)

The media becomes soiled when printed

Are the print heads dirty?

The following may cause ink to drip on the media during printing.

- Buildup of fibrous dust (lint) around the heads
- Ink transferred to the heads due to rubbing against the media
If this happens, perform powerful cleaning. We recommend carrying out periodic cleaning of the print heads.
- Too low humidity
Use this machine in a 40%RH to 60% RH (non-condensation) environment.

RELATED LINKS

- [P. 234 Periodical Cleaning Maintenance](#)

Are the pinch rollers or the media clamps dirty?

Periodically clean them.

RELATED LINKS

- [P. 225 Cleaning the Machine](#)

Cutting is misaligned or skewed

Is the media loaded and set up correctly?

If the media is not loaded and set up correctly, or media feed is not smooth, cutting may be adversely affected. Make sure the media is loaded and set up correctly.

RELATED LINKS

- [P. 267 Media Feed Problems](#)

Are the settings for the cutting conditions appropriate?

Misalignment or skewing may occur if the cutting speed is too fast or the blade force is too high. Try changing the cutting conditions. With media having a strong adhesive layer, the adhesive layer reattaches to itself immediately after cutting. However, if a cutting test shows that the peeling of the media and the blade traces on the backing paper are optimal, the media is being cut properly. Be careful not to make the blade force too high.

RELATED LINKS

- [P. 157 Fine-tuning the Cutting Conditions](#)
- [P. 159 Adjusting the Amount of Blade Extension](#)

Is the length of output too long?

For printing & cutting in particular, the longer the page length (that is, the longer the distance the media is returned after printing), the greater is the chance of misalignment occurring. It is a good idea to keep the size of each single page to the minimum necessary.

Are you using media that exhibits large expansion and contraction?

When you are performing printing followed immediately by cutting, misalignment occurs if the media expands or contracts. If this happens, try performing printing with crop marks followed by cutting. This corrects for the expansion and contraction of the media.

RELATED LINKS

- [P. 119 How to Cut with Crop Marks](#)
- [P. 167 Accurately Adjusting the Settings for Cutting with Crop Marks](#)

Is the setting for the [Cutting Distance Correction] menu item (under [List of Media Settings]) correct?

When you are performing printing followed immediately by cutting, go to [List of Media Settings] and set the [Cutting Distance Correction] correction value to 0.00%.

RELATED LINKS

- [P. 160 Performing Distance Correction during Cutting](#)

Have you corrected the misalignment of printing and cutting?

Misalignment between the printing and cutting positions may occur due to the thickness of the media or the head height. Make corrections for misaligned printing and cutting for the media you are using.

RELATED LINKS

- [P. 163 Accurately Adjusting the Settings for Printing and Cutting](#)

Is the cutting tool installed appropriately?

When installing the cutting tool, firmly tighten the screw and check that the cutting tool is fixed in place.

RELATED LINKS

- [P. 248 Replacing the Blade](#)

Is the blade worn?

A worn or chipped blade will negatively affect the cutting quality. Check the status of the blade and replace it with a new one if necessary.

RELATED LINKS

- [P. 248 Replacing the Blade](#)

Is there any buildup of pieces of media or dust inside the blade holder?

Remove the blade holder, and then take off the tip of the blade holder and remove any pieces of media or dust inside.

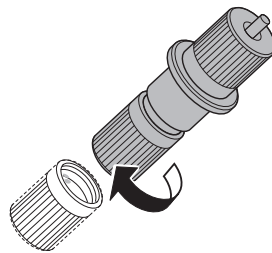

After cleaning, adjust the amount of blade extension.

RELATED LINKS

- [P. 159 Adjusting the Amount of Blade Extension](#)

The printed surface is damaged when cutting

Does the tip of the blade holder cap scrape the printed surface?

The tip of the blade holder cap may scrape, and soil or damage the printed surface. If this happens, increase the amount of blade extension.

RELATED LINKS

- [P. 159 Adjusting the Amount of Blade Extension](#)

Problems in Cutting with Crop Marks

Automatic Detection of Crop Marks Fails	265
Is the media wrinkled or warped?	265
Is the media size too large?.....	265
Are you using media that is likely to reflect light?	265
Are you using transparent media?	265
Printing and Cutting Are Misaligned	266
Have you corrected the misalignment of printing and cutting with crop marks?	266

Automatic Detection of Crop Marks Fails

Is the media wrinkled or warped?

Wrinkled or warped media may cause crop mark detection to fail. Avoid using wrinkled or warped media.

RELATED LINKS

- [P. 179 Correcting the Reading Sensor \(Multi Sensor Adjustment\)](#)

Is the media size too large?

Large media may lead to large errors, which may cause crop mark detection to fail.

When you want to use lengthy media, we recommend performing output with the data separated into sizes that are as short as possible.

Are you using media that is likely to reflect light?

The machine may not be able to read crop marks from media that is likely to reflect light. Try [**Multi Sensor Adjustment**] (the correction function of the sensor for reading crop marks). If the crop marks still cannot be read, change the media you are using.

RELATED LINKS

- [P. 179 Correcting the Reading Sensor \(Multi Sensor Adjustment\)](#)

Are you using transparent media?

The machine cannot read crop marks from transparent media. Change the media you are using.

Printing and Cutting Are Misaligned

Have you corrected the misalignment of printing and cutting with crop marks?

Depending on the composition of the media, the positioning of printing and cutting may be misaligned even when you are using crop marks. Make corrections for misaligned printing and cutting for the media you are using.

RELATED LINKS

- [P. 167 Correcting the Misalignment of Printing and Cutting with Crop Marks \(Crop Cut Position Adjustment \[Media Not Removed\]\)](#)
- [P. 172 Correcting the Misalignment of Printing and Cutting with Crop Marks \(Separate Test for Printing and Cutting with Crop Marks \[Media Removed\]\)](#)

Media Feed Problems

Media Wrinkles or Shrinks	268
Is the media loaded securely and straight?	268
Was loaded media allowed to stand for some time?.....	268
Are the media clamps installed?	268
Was the media loaded while the print heater was hot?.....	268
Is the temperature of room too low?.....	268
Is the humidity of the room too high?.....	268
Is the using media deflected?	268
Media Feed Is Not Straight	269
Is the media loaded securely and straight?	269
Media Feed Is Not Smooth.....	270
Is some other object coming into contact with the media?	270
Is the media too thick?	270
Are the grit rollers dirty?.....	270
A Media Jam Occurs!	271
Is an error message displayed?	271
Is the media warped or wrinkled?	271
Are the grit rollers dirty?.....	271
Are the media clamps installed?	271
Is the media loaded securely and straight?	271
Is some other object coming into contact with the media?	271
Is the media too thick?	272
Is the machine's installation site appropriate?	272
Is the machine on a table of the recommended size?	272

Media Wrinkles or Shrinks

Is the media loaded securely and straight?

Feeding is not smooth when the media is not straight or is tensioned unevenly on the left and right. Reload the media.

RELATED LINKS

- [P. 37 Setup of New Media](#)
- [P. 63 Setup of Registered Media](#)

Was loaded media allowed to stand for some time?

Media may shrink or wrinkle if it is heated for an extended time. When printing ends, switch off the sub power and remove the media.

Are the media clamps installed?

When you are performing printing, be sure to install the media clamps.

Was the media loaded while the print heater was hot?

Loading media after the heater has warmed up causes the temperature of the media to rise suddenly, which may cause the media to shrink or wrinkle during printing. Before loading media, switch off the sub power and allow the platen to cool.

RELATED LINKS

- [P. 147 Adjusting the Ink-drying Method](#)

Is the temperature of room too low?

Use this machine in an environment having an ambient temperature of 20 to 28°C (68 to 82.4°F). If the machine is used at an ambient temperature less than 20°C, then depending on the type or width of the media, wrinkling or temperature-caused unevenness may occur. To obtain stable printing results, the machine should be used at an ambient temperature of 20 to 28°C (68 to 82.4°F).

Is the humidity of the room too high?

Use the machine in an environment with a humidity of 40 to 60%RH (no condensation). High humidity can cause the media to sag. If sagging media is used, it may come out wrinkled.

Is the using media deflected?

If using the deflected media, it cause wrinkle of the media.

Media Feed Is Not Straight

Is the media loaded securely and straight?

Feeding is not smooth when the media is not straight or is tensioned unevenly on the left and right. Reload the media.

RELATED LINKS

- [P. 37 Setup of New Media](#)
- [P. 63 Setup of Registered Media](#)

Media Feed Is Not Smooth

Is some other object coming into contact with the media?

Make sure that nothing touches the media. This may affect output, even when the feed appears to be smooth.

RELATED LINKS

- [P. 37 Setup of New Media](#)
- [P. 63 Setup of Registered Media](#)

Is the media too thick?

Media that is too thick may not only cause unstable feed, but may scrape the print heads, resulting in malfunction. Never use such media.

Are the grit rollers dirty?

Check to make sure the grit rollers are free of buildup of foreign material such as media scraps.

RELATED LINKS

- [P. 225 Cleaning the Machine](#)

A Media Jam Occurs!

Is an error message displayed?

If an error message is displayed because the media has jammed, immediately correct the problem. Doing so may damage the print heads.

RELATED LINKS

- [P. 283 Error Messages](#)

Is the media warped or wrinkled?

Many factors can cause warping or wrinkling. Refer to the following and correct the problem.

RELATED LINKS

- [P. 267 Media Feed Problems](#)

Are the grit rollers dirty?

Check to make sure the grit rollers are free of buildup of foreign material such as media scraps.

RELATED LINKS

- [P. 225 Cleaning the Machine](#)

Are the media clamps installed?

When you are performing printing, be sure to install the media clamps.

Is the media loaded securely and straight?

Feeding is not smooth when the media is not straight or is tensioned unevenly on the left and right. Reload the media.

RELATED LINKS

- [P. 37 Setup of New Media](#)
- [P. 63 Setup of Registered Media](#)

Is some other object coming into contact with the media?

Make sure that nothing touches the media. This may affect output, even when the feed appears to be smooth.

RELATED LINKS

- [P. 37 Setup of New Media](#)
- [P. 63 Setup of Registered Media](#)

Is the media too thick?

Media that is too thick may not only cause unstable feed, but may scrape the print heads, resulting in malfunction. Never use such media.

Is the machine's installation site appropriate?

Check the machine's installation space. If the space in front of the machine is insufficient, media may be jammed between the roll media loaded on the media holders and the media feed rollers during media pullback.

RELATED LINKS

- [BY-20 "Machine Installation" > "Installing the Machine" > "Installation Space"](#)

Is the machine on a table of the recommended size?

When printing and cutting media that is longer than 500 mm (19.69 in.), the media may jam due to contact between the media and the table when the media is pulled back. Install the machine on a table of the recommended size.

RELATED LINKS

- [BY-20 "Machine Installation" > "Installing the Machine" > "Installation Space"](#)

Machine Problems

Why Has the Print-Head Carriage Stopped Moving?	274
What to Do First	274
If the Print Heads Still Do Not Move	274
The Printer Unit Doesn't Run	276
Is the power switched on?	276
Is [Output possible.] displayed in the Utility window?	276
Are any covers open?	276
Is the message [Output is currently paused.] displayed in the Utility window?	276
Is a message displayed in the Utility window?	276
Is an [Ink Cartridge Error] displayed?	276
Are the cables connected?	277
The Media Heating System Doesn't Warm Up	278
Has the media been set up?	278
Is the temperature of the room too low?	278
Cannot Separate the Media	279
Are the separating knife and media clamps attached?	279

Why Has the Print-Head Carriage Stopped Moving?

If the print-head carriage stops over the platen, take action immediately to prevent the heads from drying out.

What to Do First

Switch the sub power off and then back on again. If the media is jammed, remove the media.

If the print-head carriage moves to the home position (the right side of the main unit), the operation has ended successfully.

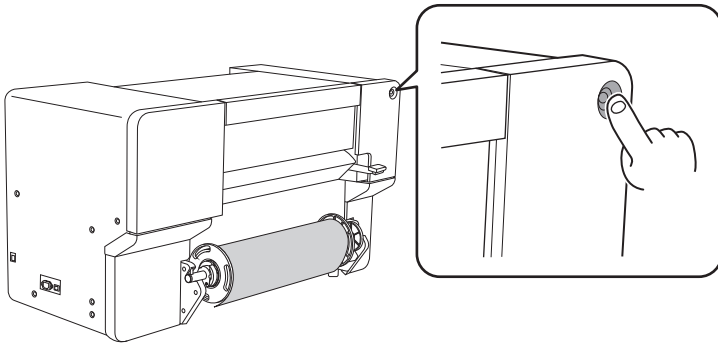

If the print-head carriage still does not move

Turn off the sub power, followed by the main power. Then, switch on the main power again, followed by the sub power.

If the Print Heads Still Do Not Move

If the print heads still do not move even though you have performed the actions under "What to Do First," carry out the following emergency response measure, and then contact your authorized dealer.

Procedure

1. Switch off the sub power.
2. Turn off the main power switch.

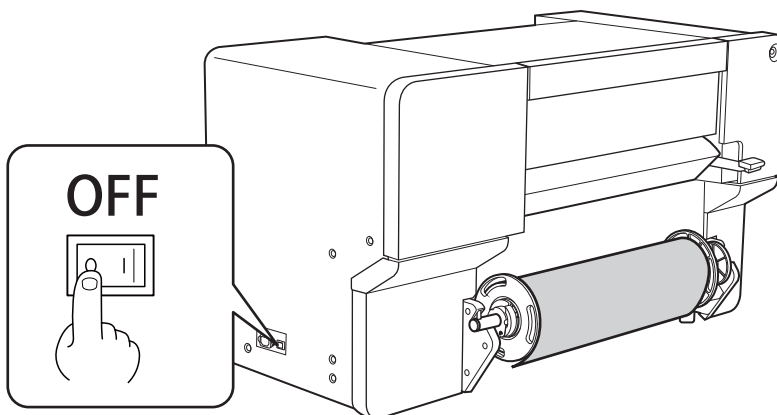

3. Open the front cover.

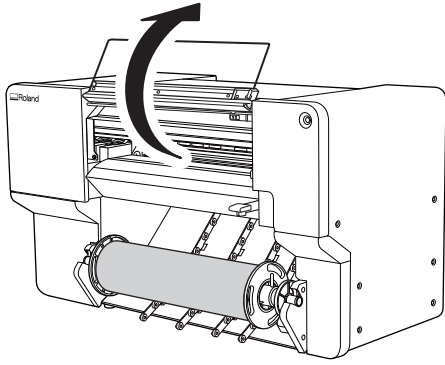

- 4. Gently move the print-head carriage to the home position by hand.**
Move the print-head carriage to the right until it stops.

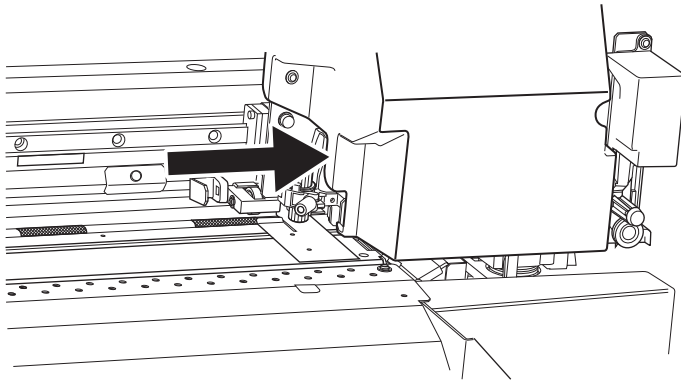

The Printer Unit Doesn't Run

Is the power switched on?

Switch on the printer's main power, followed by the sub power and make sure  appears in the Utility window.

Is [Output possible.] displayed in the Utility window?

Output is not performed when [Output possible.] is not displayed at the top of the Utility window. Load the media, lower the loading lever, and then click  [Setup]. Follow the instructions on the screen to finish setting up the media.

Also, when operating the setting menu, output doesn't start when data is sent from the computer with some menu items. When you return to a menu item where output is possible or to the Utility home screen, output starts.

Are any covers open?

Close all the covers.

Is the message [Output is currently paused.] displayed in the Utility window?

When output is paused, the message [Output is currently paused.] is displayed in the Utility window. To resume output, click [Resume].

RELATED LINKS

- [P. 88 Pausing and Resuming Output](#)

Is a message displayed in the Utility window?

Check the message displayed in the Utility window.

RELATED LINKS

- [P. 281 Messages](#)
- [P. 283 Error Messages](#)

Is an [Ink Cartridge Error] displayed?

When an [Ink Cartridge Error] appears in the Utility window, output data cannot be accepted.

If there is data that has not yet been output remaining in the machine, output resumes when the error is cleared. If there is unsent data in the computer, output resumes when the data is resent.

When ink runs out

Replace the empty ink cartridge with a new one.

When an ink cartridge with the incorrect color is loaded

Remove the ink cartridge that was loaded incorrectly and load the appropriate ink cartridge.

When an ink cartridge is removed or has not been securely loaded

Securely load the ink cartridge by pushing it all the way to the back.

RELATED LINKS

- [P. 241 Replacing Ink Cartridges](#)
- [P. 283 Error Messages](#)

Are the cables connected?

Connect the cables securely.

RELATED LINKS

- [BY-20 "Machine Installation"](#)

The Media Heating System Doesn't Warm Up

Has the media been set up?

By default, simply switching on the power does not make the media heating system warm up to the preset temperature. Set up the media and wait for the machine to warm up.

RELATED LINKS

- [P. 147 Adjusting the Ink-drying Method](#)

Is the temperature of the room too low?

Use the machine in an environment where the temperature is 20°C to 28°C (68°F to 82.4°F).

The media heating system may not warm up sufficiently when the ambient temperature is less than 20°C (68°F). Also, even when the media heating system reaches its set temperatures, adequate effectiveness may not be apparent if the media is thoroughly chilled. Before printing, allow the media to come to room temperature.

Cannot Separate the Media

Are the separating knife and media clamps attached?

If the separating knife and media clamps are not attached, you cannot separate the media.

Handling Messages and Error Messages

Messages	281
[When output, cleaning, and other operations are completed, discard the discharged fluid.]	281
[The time for Daily shut down cleaning has arrived.]	281
[The time for wiper replacement has arrived.]	281
[The time for felt wiper replacement has arrived.]	281
[Print head protection mode has activated.]	281
[High-temperature alert]	281
Error Messages	283
[Ink Cartridge Error]	283
[Cover Open Error]	283
[Media End Error]	283
[Loading Lever Error]	284
[Media Loading Error]	284
[Replace the drain pack.]	284
[Crop Mark Detection Error]	285
[Pinch Roller Error]	285
[Insufficient Media Width]	285
[Media clamps could not be detected.]	286
[The connection to the unit was lost.]	286
[Motor Error]	286
[Print Head Dry-out Error]	287
[Low Temperature Error]	287
[High Temperature Error]	287
[Pump Stop Error]	288
[Cleaning Error]	288
[Service Call]	288

Messages

These are the main messages that appear in the Utility window to prompt correct operation. These messages are not errors, so you can close them and perform other work.

To check messages again or to carry out their corresponding actions, click  on the home screen to display the list of messages. Click a message to display the menus and procedure required for the action. Perform operations according to the on-screen instructions.

[When output, cleaning, and other operations are completed, discard the discharged fluid.]

This message appears when a certain amount of discharged fluid collects in the drain pack.

Click [When output, cleaning, and other operations are completed, discard the discharged fluid.]>[Execute] to discard the discharged fluid.

[The time for Daily shut down cleaning has arrived.]

This message appears when it is time to perform daily shut-down cleaning.

Click [Manual Cleaning]>[Daily shut down cleaning]>[Execute] and perform daily shut-down cleaning.

[The time for wiper replacement has arrived.]

This message appears when it is time to replace the wiper.

Click [The time for wiper replacement has arrived.]>[Execute] and replace the wiper.

RELATED LINKS

- [P. 243 Replacing the Wiper](#)

[The time for felt wiper replacement has arrived.]

This message appears when it is time to replace the felt wiper.

Click [The time for felt wiper replacement has arrived.]>[Execute] and replace the felt wiper.

RELATED LINKS

- [P. 245 Replacing the Felt Wiper](#)

[Print head protection mode has activated.]

This message appears when the ink in use may not be a product specified by Roland DG Corporation.

If the ink is not a product specified by Roland DG Corporation, a larger amount of ink will be consumed, and drying will be performed frequently. To obtain optimal performance, we recommend that you use ink specified by Roland DG Corporation. To purchase ink, contact your authorized dealer.

[High-temperature alert]

This message appears when the environment temperature exceeds 28 °C (82.4 °F) during operation.

Messages

If you continue printing, the product may be affected. Use the machine in an environment where the temperature is in the range of 20°C to 28°C (68°F to 82.4°F).

Error Messages

This section describes the error messages that may appear in the Utility window and how to take action to remedy the problem. In addition to the messages described below, the Utility window shows the causes of errors and troubleshooting information. If the troubleshooting information displayed in the Utility window or action described here does not correct the problem or if an error message not described here appears, contact your authorized dealer.





[Ink Cartridge Error]

This message appears when one of the following ink cartridge errors is detected.

MEMO

When an error occurs, the , , , or  icon is displayed next to the corresponding ink type on the screen.

Implement appropriate countermeasures according to the error.

- **When ink runs out**
 -  [Ink has run out.]
Replace the ink cartridge with a new one.
- **When little ink remains**
 -  [Remaining ink level low.]
Printing is not possible if there is no ink. If this message appears, prepare a replacement ink cartridge.
- **When an ink cartridge is removed**
 -  [Ink cartridge was removed.]
Load the removed ink cartridge.
- **When an ink cartridge with the incorrect color is loaded**
 -  [Incorrect ink cartridge was loaded.]
Remove the incorrectly loaded ink cartridge, and then load the correct ink cartridge.
When an ink cartridge is removed,  [Ink cartridge was removed.] is displayed.

[Cover Open Error]

At least one cover is open.

For safety, the machine may stop if a cover is opened during operation.

Close all the covers.

[Media End Error]

This message appears when one of the following situations is detected.

- Insufficient remaining media during printing output
- No media during media feeding

Switch to new media, and then send the data again.

[Loading Lever Error]

This message appears when the loading lever is raised during media setup or after completing this setup.

Lower the loading lever, and then redo setup.

RELATED LINKS

- [P. 37 Setup of New Media](#)
- [P. 63 Setup of Registered Media](#)

[Media Loading Error]

This message appears when [Enable Detection] under [Media Edge Detection Method] is set to on and media has not been fed with the pinch rollers set incorrectly.

Raise the loading lever, set the pinch rollers correctly, and then set up the media again.

This message appears when [Enable Detection] under [Media Edge Detection Method] is set to on and the media is too short.

The media is not long enough to be detected. Raise the loading lever, set [Enable Detection] under [Media Edge Detection Method] to off, and then reload the media.

For the setup method when [Enable Detection] under [Media Edge Detection Method] is set to off, refer to [2. B: Determining the Positions of Media \(If \[Media Edge Detection Method\]: Off\)](#).

RELATED LINKS

- [P. 37 Setup of New Media](#)
- [P. 63 Setup of Registered Media](#)

[Replace the drain pack.]

This message appears when the drain pack has reached its limit for discharged fluid.

Replace the drain pack that is inside the drain cartridge.

MEMO

When the drain cartridge is detached, the error message changes to [The drain cartridge was removed.].

IMPORTANT

Damage to the protrusion on the drain cartridge will make it impossible for the machine to recognize the drain cartridge, resulting in a drain cartridge error.

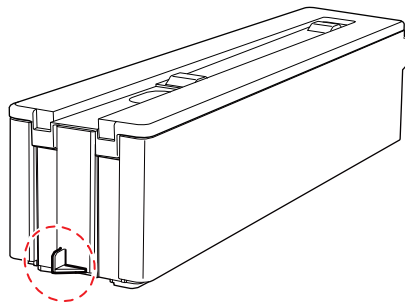

[Crop Mark Detection Error]

[Crop marks could not be detected.]

Automatic detection of crop marks could not be accomplished.

Try to make corrections using **[Multi Sensor Adjustment]** (the correction function of the sensor for reading crop marks). Depending on the media, it may not be possible to detect crop marks automatically.

[Crop marks were detected however the size or position was incorrect.]

Automatic detection of crop marks could not be accomplished.

Load the media at the correct position and perform detection of crop marks again. If repeating automatic crop-mark detection also results in an error, start over again from the printing of crop marks.

RELATED LINKS

- [P. 37 Setup of New Media](#)
- [P. 63 Setup of Registered Media](#)
- [P. 119 How to Cut with Crop Marks](#)

[Pinch Roller Error]

The left pinch roller is positioned at a location where it cannot pinch the media.

Raise the loading lever and move the pinch roller to the correct location.

RELATED LINKS

- [P. 37 Setup of New Media](#)
- [P. 63 Setup of Registered Media](#)

[Insufficient Media Width]

[The print data is larger than the media width. Continue output?]

This message appears when the size of the printing data is larger than the printing area of the loaded media.

To continue performing output without correcting this, click **[Yes]**. At this time, the portion extending beyond the printing area is not output.

To cancel output, click **[No]**. Make the printing area wider, for example, by replacing the media with a larger piece of media, and then send the data again.

MEMO

There is no limitation on the size of the data in the media-feed direction (the longitudinal direction).

[Crop marks cannot be added because the print data is larger than the media width. Continue output?]

This message appears when one of the following situations is detected.

- The size of the data with crop marks is larger than the printing area of the loaded media.
- The width of the printing data is less than 60 mm (2.36 in.).

To continue performing output without correcting this, click **[Yes]**. The data is output without printing the crop marks.

- The size of the data with crop marks is larger than the printing area of the loaded media.
Make the printing area wider, for example, by replacing the media with a larger piece of media, and then send the data again.
- The width of the printing data is less than 60 mm (2.36 in.).
Make the horizontal-direction (scan-direction) size of the data at least 60 mm (2.37 in.), and then send the data again.

[Media clamps could not be detected.]

This message appears when the left media clamp cannot be detected during sheet cutting.

- The left media clamp is hidden by the media.
- The left media clamp is not attached.

Check the loading status of the media and that the pinch rollers have been positioned correctly, and then correctly set the media clamps at the ends of the media.

This message appears when the media clamps cannot be detected because their parts that are read are dirty with, for example, ink.

Use cleaning liquid and a cleaning stick to clean the white parts on the media clamps.

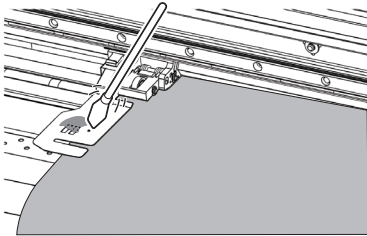

It may not be possible to detect the media clamps because the multi sensor is dirty with ink due to reasons such as the media striking it immediately after printing.

Install the media clamps correctly and clean their parts that are read. If this message still appears, contact your authorized dealer.

RELATED LINKS

- [P. 37 Setup of New Media](#)
- [P. 63 Setup of Registered Media](#)

[The connection to the unit was lost.]

This message appears when one of the following situations is detected.

- The main power of this machine switches off.
- The IP address of this machine is changed.
- The LAN cable connecting this machine and the computer is disconnected.

If the main power is left off, the automatic maintenance function will not be able to operate, which may result in malfunctions. Always keep the main power switched on.

[Motor Error]

A motor error occurred.

Operation cannot be continued. Turn off the sub power. Next, eliminate the cause of the error, then immediately switch on the sub power.

If the machine is allowed to stand with the error uncorrected, the print heads may dry out and become damaged. This error may be caused by such factors as a mistake in loading the media, a media jam, or an operation that pulls the media with excessive force.

The media has jammed.

Carefully remove the jammed media. The print heads may also be damaged. Perform head cleaning, and then perform a printing test and check the results.

Has the media been pulled with excessive force?

Excessive tension was applied to the media, and additional action is necessary to recover from this state. First, raise the loading lever and adjust the media to create a small amount of slack, and then switch on the sub power.

[Print Head Dry-out Error]

This message appears when the print heads are forced to the home position to prevent them from drying out.

Operation cannot be continued. Switch the sub power off, and then back on.

[Low Temperature Error]

The temperature of the location where the machine is installed has fallen below the ambient temperature at which the machine can operate.

This message appears when the temperature falls to 5°C (41°F) or lower during startup or to 2°C (35.6°F) or lower during operation.

Operation cannot be continued. Turn off the sub power.

The displayed temperature is the current ambient temperature of the installation location. Bring the installed location to a temperature at which operation is possible (20°C to 28°C [68°F to 82.4°F]), allow the machine to come to room temperature, and then turn on the power.

RELATED LINKS

- [P. 31 Power Supply Operations](#)

[High Temperature Error]

The temperature of the location where the machine is installed has risen above the ambient temperature at which the machine can operate.

This message appears when the temperature rises to 42°C (107.6°F) or higher during startup or operation (when recovering from sleep mode).

Operation cannot be continued. Turn off the sub power.

The displayed temperature is the current ambient temperature of the installation location. Bring the installed location to a temperature at which operation is possible (20°C to 28°C [68°F to 82.4°F]), allow the machine to come to room temperature, and then turn on the power.

RELATED LINKS

- [P. 31 Power Supply Operations](#)

[Pump Stop Error]

This message appears when an ink cartridge is pulled out during pump operation, such as during cleaning, and is left in this state for 10 minutes or more.

Operation cannot be continued. Switch the sub power off, and then back on.

[Cleaning Error]

This message appears when ink runs out during cleaning.

Operation cannot be continued. Switch the sub power off, and then back on.

After switching the sub power off and back on to clear the error, perform the interrupted operation again.

[Service Call]

An unrecoverable error occurred, or part replacement that must be performed by a service technician is required

Note the number displayed in the Utility window, and then switch off the main power. After you switch off the power, inform your authorized dealer of the number that appeared in the Utility window.

Appendix

Operations When Moving the Unit

Preparing to Move the Machine.....	291
Procedures from Preparing to Move to Reinstallation	291

Preparing to Move the Machine

To move the machine, you must completely drain all ink inside the machine and secure the print-head carriage in place with a retainer. Attempting to move the machine without first doing this may result in damage to the print heads or damage to internal components due to leaking ink.

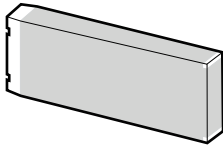
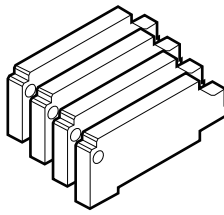
Required items	
	
Unused cleaning cartridge (1)	Dummy cartridges (4)

To purchase items that are sold separately, contact your authorized dealer.

IMPORTANT

Make sure to use a cleaning cartridge that corresponds to the ink type. Using the wrong cartridge may cause a machine malfunction.

Procedures from Preparing to Move to Reinstallation

Procedure

1. Start Utility.
[P. 15 Starting/Exiting Utility](#)
2. Click ☰.
3. Click [Execute] under [Maintenance]>[Ink]>[Head Cleaning].
Proceed with the work by following the on-screen instructions. Do not switch off the power until the work is completed.

Preparing to Move the Machine

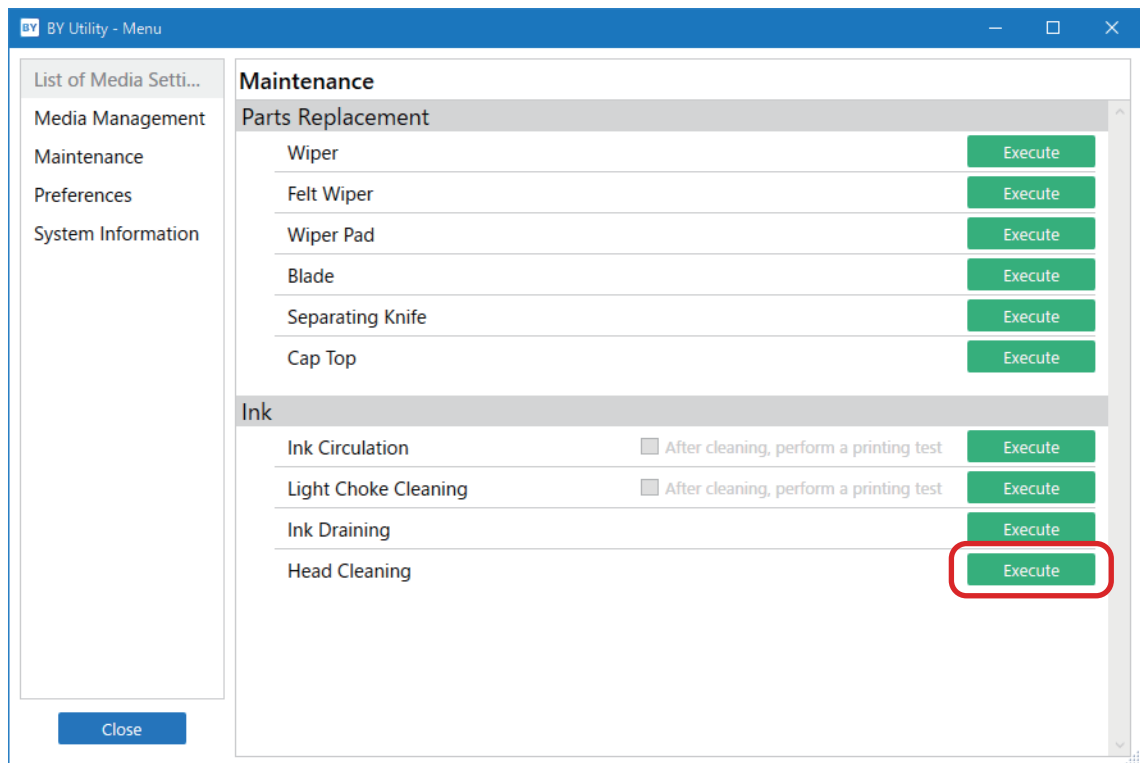

4. Close any covers that are open.
5. Turn off the sub power, and then switch off the main power.
6. Secure the print-head carriage with a retainer.
 - (1) Open the lower-left cover, and then remove the retainer and screw.

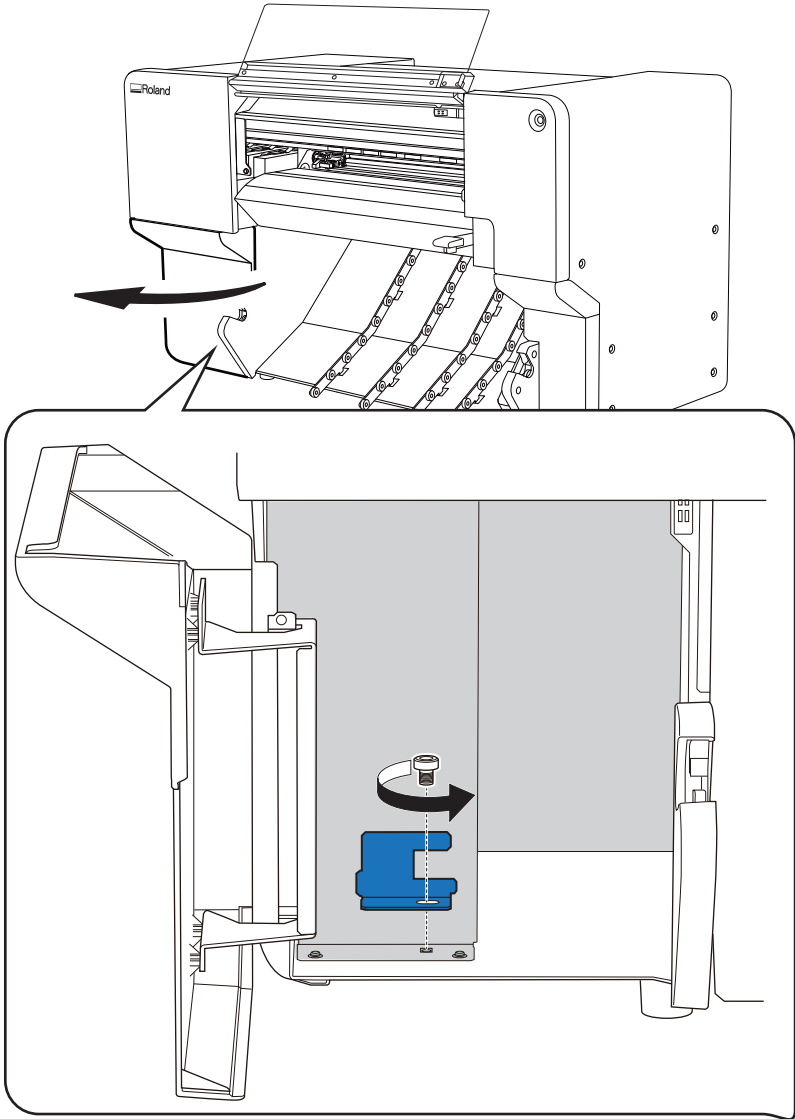

(2) Open the front cover, and then secure the print-head carriage with the retainer.

Temporarily tighten the screw, lightly press the retainer against the print-head carriage, and then fully tighten the screw.

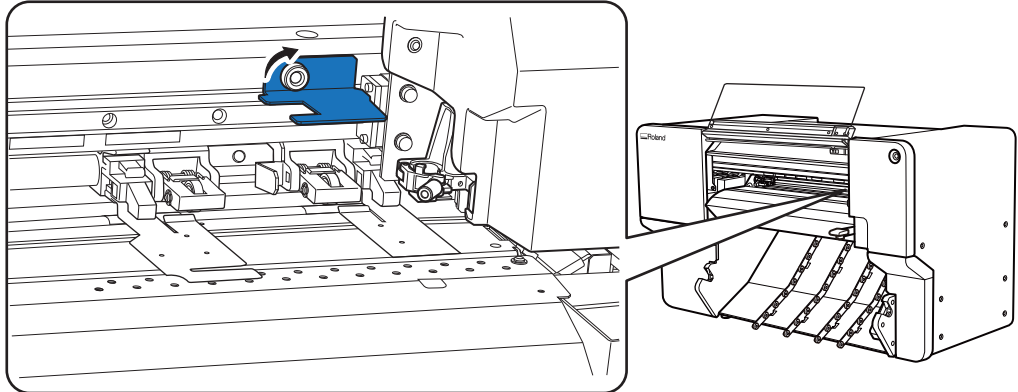

(3) Close the front and lower-left covers.

- 7. Move the machine as soon as possible.
- 8. After moving the machine, immediately install it.

9. Remove the print-head carriage's retainer.

(1) Open the front cover, and then remove the retainer.

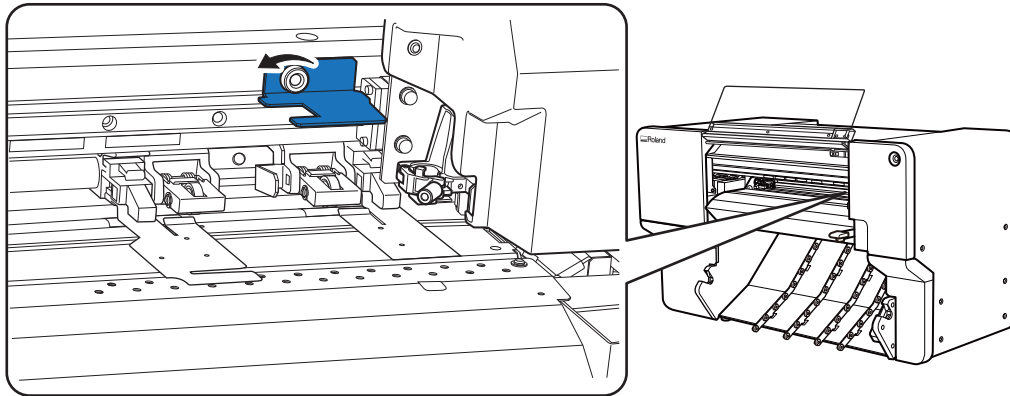

(2) Open the lower-left cover to store the removed retainer and screw.

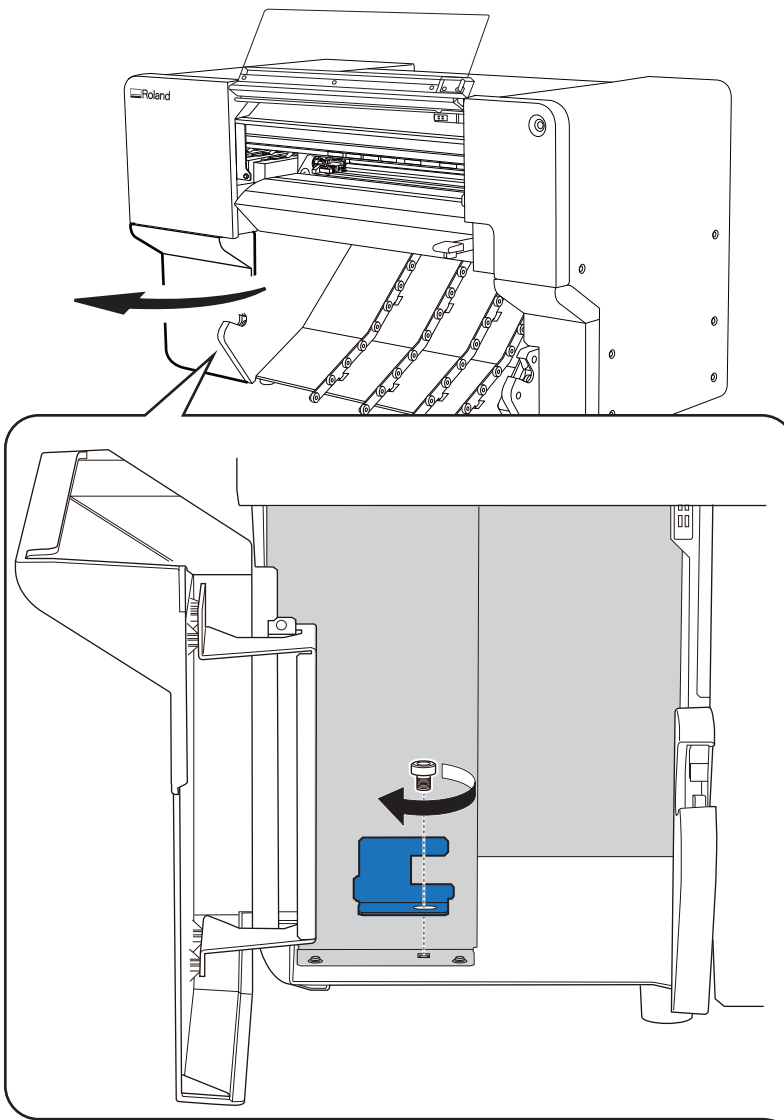

(3) Close the front and lower-left covers.

10. Turn on the main power, and then switch on the sub power.

11. Fill with ink.

After reinstalling the machine, a message prompting you to fill it with ink appears when you start Utility. Follow the on-screen instructions to promptly carry out the ink filling.

IMPORTANT

Important notes on moving

- Once the preparations for moving are complete, move the machine and fill it with ink with as little delay as possible. Leaving the machine alone without ink may damage the print heads.
- When moving the machine, keep it at a temperature of 5°C to 40°C (41°F to 104°F) and at a humidity of 20%RH to 80%RH (with no condensation). Failure to do so may result in malfunction.
- Handle the machine with care when moving it, keeping it level (not tilted at an angle) and preventing it from striking other objects.

RELATED LINKS

- <https://downloadcenter.rolanddg.com/BY-20>

Main Specifications

- Printing Area 297
 - Maximum Area 297
 - Maximum Area When Using Crop Marks 298
 - Media Separation Location during Continuous Printing 299
- About the Blade..... 300
- Specifications 301

Printing Area

Maximum Area

The printing or cutting area along the horizontal plane of the loaded media (the direction in which the print-head carriage moves) is determined by the positions of the pinch rollers.

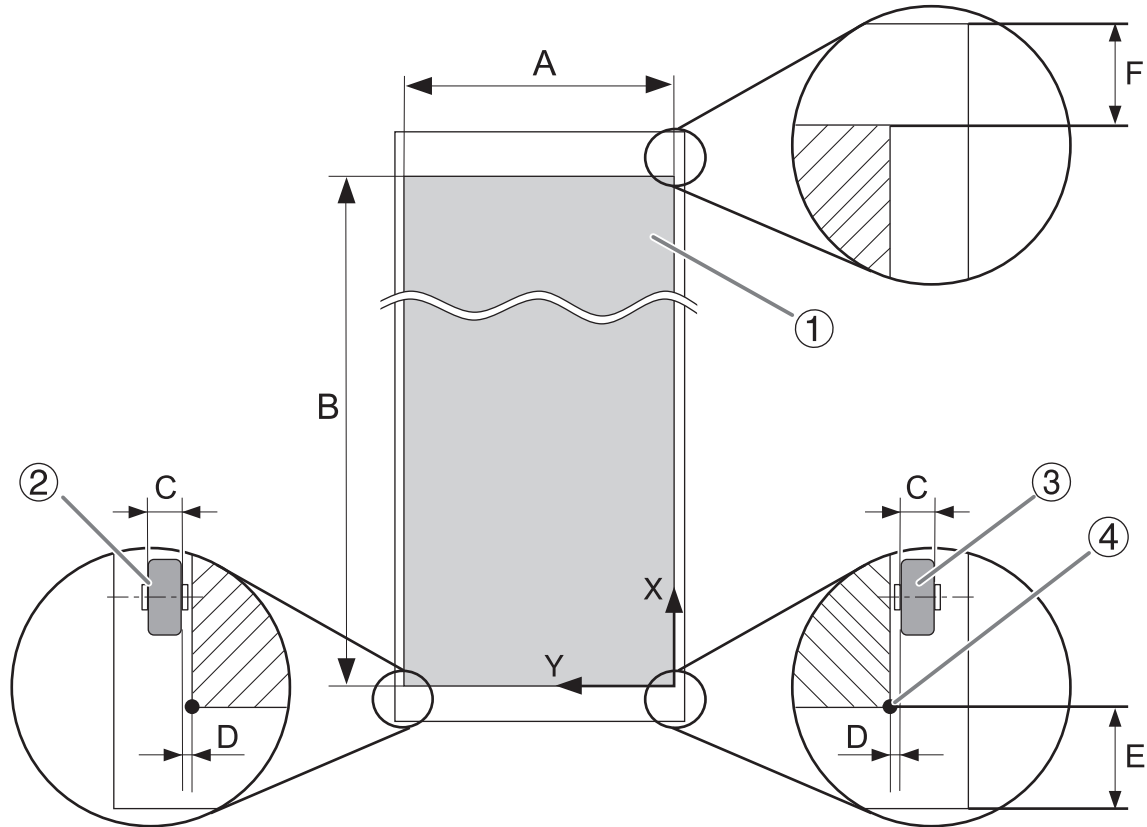

①	Printing or cutting area
②	Left pinch roller
③	Right pinch roller
④	Printing or cutting coordinates origin (0,0)
A	Max. 480 mm (18.89 in.)
B	Max. 24,998 mm (984.2 in.)
C	5 mm (0.2 in.)
D	1.5 mm (0.06 in.)
E	75 mm (3 in.)
F	70 mm (2.76 in.)

Maximum Area When Using Crop Marks

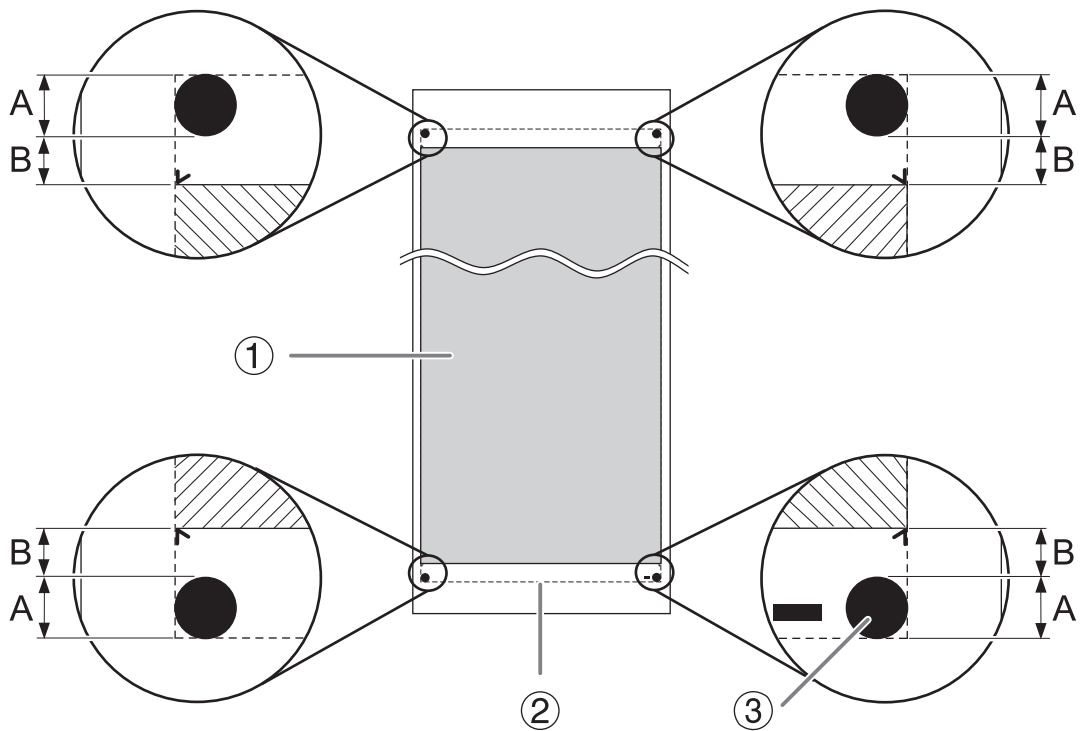

①	Printing or cutting area
②	Maximum area
③	Crop mark
A	12.5 mm (0.5 in.)
B	10 mm (0.4 in.)

Media Separation Location during Continuous Printing

When a command for separating the media is sent from the computer, the separation location on the media is as shown in the figure below.

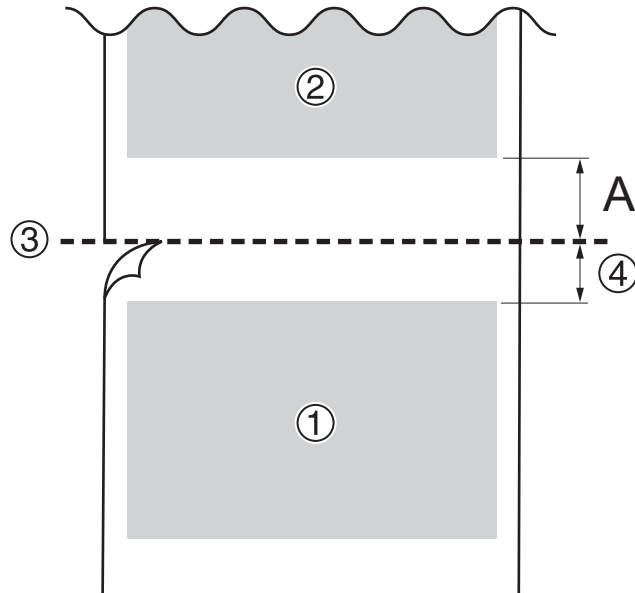

①	First page
②	Second page
③	Separation location
④	Margin (software RIP value)
A	75 mm (3 in.)

About the Blade

The cutting conditions and the service life of the blade change according to the media and the operating environment, even when you're using identical blades. The service life also differs according to the type of blade. A rough guide is shown below.

Blade	Media	Blade force	Amount of blade offset (amount of blade tip correction)	Blade life (general guide)*1
ZEC-U5032	General Signage Vinyl	50 to 150 gf	0.25 mm (0.01 in.)	8000 m (26,246.72 ft.)
ZEC-U5025	General Signage Vinyl	30 to 100 gf	0.25 mm (0.01 in.)	4000 m (13,123.36 ft.)
	Fluorescent Vinyl	120 to 200 gf	0.25 mm (0.01 in.)	4000 m (13,123.36 ft.)
	Fluorescent Vinyl	100 to 200 gf	0.25 mm (0.01 in.)	4000 m (13,123.36 ft.)

*1 The values for "Blade life" are estimates for when an identical type of material is used.

MEMO

When uncut areas remain even when the blade force is increased to a value that is higher than the values shown in this chart by 50 to 60 gf, replace the blade.

Specifications

		BY-20
Printing method		Piezo ink-jet method
Media	Width	150 to 515 mm (5.91 to 20.27 in.)
	Thickness	Max. 1.0 mm (39.3 mil) with liner, for printing Max. 0.4 mm (15.7 mil) with liner and 0.22 mm (8.6 mil) without liner, for cutting
	Roll outer diameter	Max. 150 mm (5.9 in.)
	Roll weight	Max. 6 kg (13.22 lb.)
	Core diameter	76.2 mm (3 in.) or 50.8 mm (2 in.)
Printing/cutting width* ¹		Max. 480 mm (18.89 in.)
Ink	Type	S-PG2 INK 220 ml cartridge
	Colors	Five colors (cyan, magenta, yellow, black, and white)
Print resolution (dpi)		Max. 1,440 dpi
Cutting speed		10 to 150 mm/sec (0.39 to 5.9 in./sec)
Blade force* ²		30 to 500 gf
Blade	Type	Roland CAMM-1 series blade
	Offset	0.000 to 1.500 mm (0 to 0.05 in.)
Software resolution (when cutting)		0.025 mm/step (0.98 mil/step)
Media heating system* ³		Print heater set temperature: 30°C to 35°C (86°F to 95°F)
		Dryer set temperature: 30°C to 38°C (86°F to 100.4°F)
Connectivity		Ethernet (100BASE-TX/1000BASE-T, automatic switching)
Power-saving function		Automatic sleep feature
Rated input		100-240 VAC, 50/60 Hz, 2.1 A
Power consumption	During operation	Approx. 185 W
	Sleep mode	Approx. 27 W
Acoustic noise level	During operation	62 dB (A) or less
	During standby	60 dB (A) or less
Outer dimensions		1,069 (W) × 617 (D) × 622 (H) mm (42.09 [W] × 24.29 [D] × 24.49 [H] in.)
Weight		62 kg (136.69 lb.)
Environment	During operation	Temperature: 20°C to 28°C (68°F to 82.4°F) Humidity: 40% to 60% RH (no condensation)
	Not operating	Temperature: 5°C to 40°C (41°F to 104°F) Humidity: 20%RH to 80%RH (no condensation)
Included items		Power cord, media holders, replacement blade for separating knife, User's Manual, software (VersaWorks, Roland DG Connect), etc.

*1 The length of printing or cutting is subject to the limitations of the application software.

*2 • 500 gf is the maximum instantaneous blade force.

• The blade force must be adjusted according to details such as the media thickness.

*3 • Warm-up is required after power up. This may require 5 to 20 minutes, depending on the operating environment.

• Depending on the ambient temperature and the media width, the set temperature may not be reached.

