

VersaSTUDIO ***BN-20D***

Machine Installation

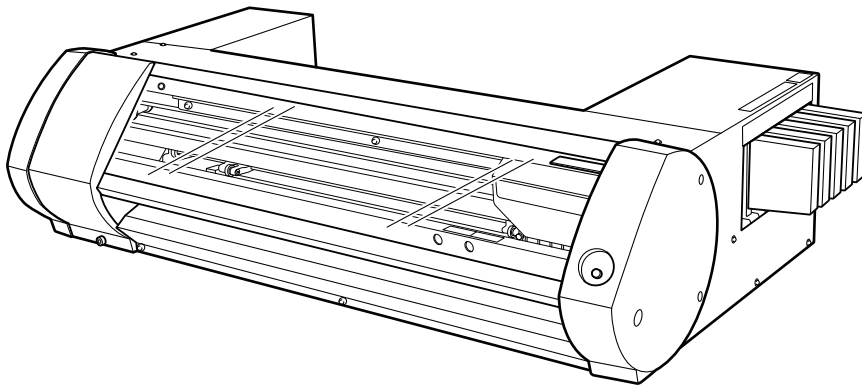

Thank you very much for purchasing this product.

- To ensure correct and safe usage with a full understanding of this product's performance, please be sure to read through this manual completely.
- Unauthorized copying or transferal, in whole or in part, of this manual is prohibited.
- The specifications of this product and the contents of this operation manual are subject to change without notice.
- The operation manual and the product have been prepared and tested as much as possible. If you find any misprints or errors, please inform us.
- Roland DG Corporation assumes no responsibility for any direct or indirect loss or damage that may occur through use of this product, regardless of any failure to perform on the part of this product.
- Roland DG Corporation assumes no responsibility for any direct or indirect loss or damage that may occur with respect to any article made using this product.

FA04192
R2-240123

<https://www.rolanddg.com/>
Copyright © 2023 - 2024 Roland DG Corporation

Contents

- Before Installation 2
 - Checking the Included Items 3
 - Temperature and Humidity 4
 - Emplacement and Installation 5
 - Installation Space 6

- Installing the Machine 7
 - Removing the Retainers 8
 - Connecting the Cables 9
 - Proceeding to Software Installation 10

Before Installation

Checking the Included Items.....	3
Temperature and Humidity	4
Emplacement and Installation.....	5
Installation Space.....	6

Checking the Included Items

The following items are included with the machine. Make sure they are all present and accounted for.

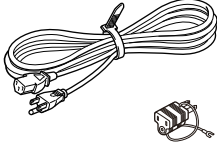
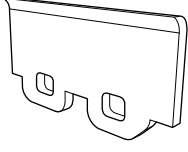
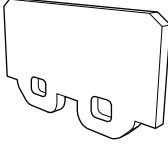
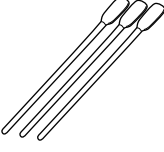
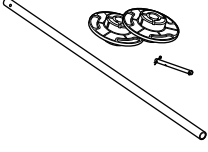
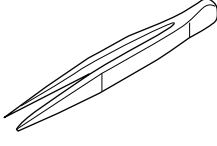
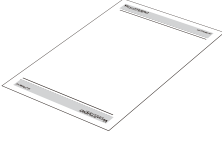
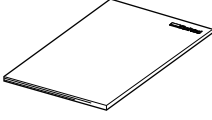
 <p>Power cord/power plug adapter*1</p>	 <p>USB cable</p>	 <p>Dummy cartridges (4)</p>	 <p>Blade holder/blade/pin</p>
 <p>Wiper</p>	 <p>Felt wiper</p>	 <p>Cleaning sticks</p>	 <p>Media flanges (2)/media bar/mounting pin</p>
 <p>Tweezers</p>	 <p>Quick Access Guide</p>	 <p>Safety Precautions</p>	

*1 Included only with 100 V specifications

Temperature and Humidity

Maintain the specified temperature and humidity even when the machine is not in use. Failure to do so may result in malfunction.



Temperature

20°C to 32°C (68°F to 89.6°F)

(During non-operation: 5°C to 40°C [41°F to 104°F])



Humidity

40~80 %RH

(During non-operation: 20%RH to 80%RH)

* No condensation

Emplacement and Installation

Install the machine in a level, stable location offering good operating conditions. An unsuitable location can cause accidents, fire, faulty operation, or breakdown.

⚠ CAUTION

Install in a level and stable location.

Failure to do so may result in falling of the machine, leading to injury.

Environments or locations where installation is not possible

- Locations subject to large fluctuations in temperature or humidity
- Locations subject to shaking or vibration
- Locations where the floor is tilted, not level, or unstable
- Dusty locations
- Locations exposed to direct sunlight
- Locations near air-conditioning or heating equipment
- Locations exposed to water or moving air
- Locations exposed to considerable electrical or magnetic noise or other forms of electromagnetic energy

⚠ CAUTION

Unloading and emplacement are operations that must be performed by 2 persons or more.

Tasks that require undue effort when performed by a small number of persons may result in physical injury. Also, if dropped, such items may cause injury.

⚠ CAUTION

When lifting the machine, hold the locations shown in the figure.

IMPORTANT

Do not hold the cover. Doing so may result in faulty operation or breakdown.

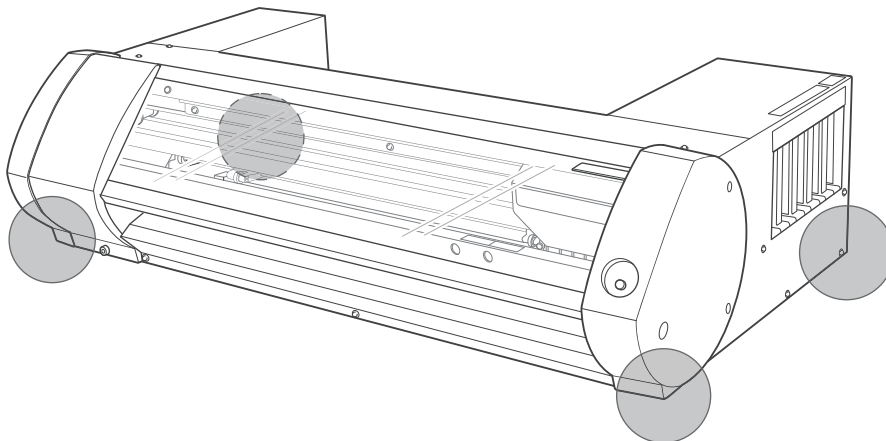

Installation Space

The space shown in the figure is required in order to use this machine.

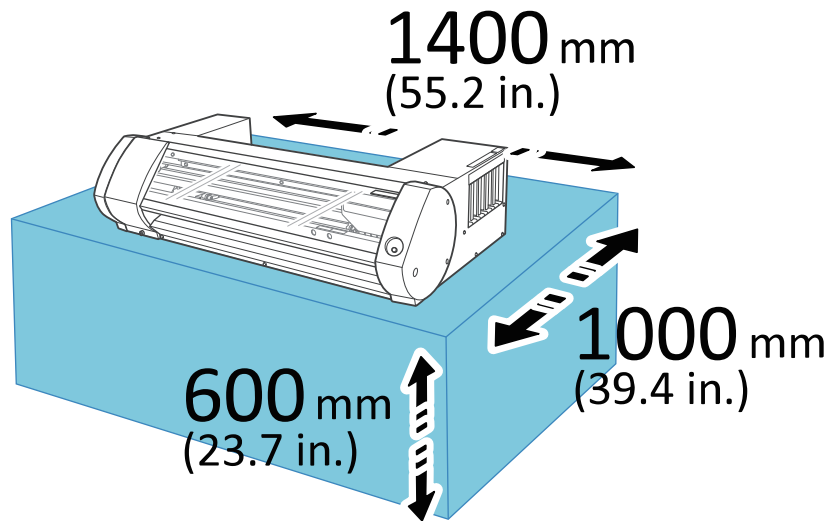

IMPORTANT

Install the machine so that it is at least 0.6 m (23.6 in.) above the work floor. This machine is desktop type. Install the machine in a location that allows easy access to areas such as the power switch and other controls during operation.

Installing the Machine

Removing the Retainers	8
Connecting the Cables	9
Proceeding to Software Installation	10

Removing the Retainers

⚠ WARNING

This work must be performed before connecting the power cord.

The power turning on inadvertently during these operations may result in pinched hands or other injury.

Be sure to remove the retainers.

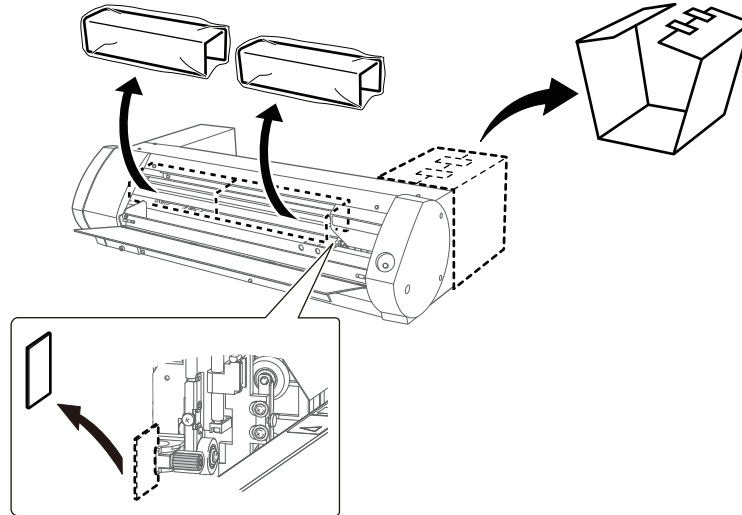

Any that remain may cause faulty operation or breakdown when the power is switched on.
Store the retainers carefully because they are needed again when transporting the machine.

Connecting the Cables

⚠ WARNING

Perform this task with all power switches left switched off.
Otherwise sudden movement of the machine may cause injury.

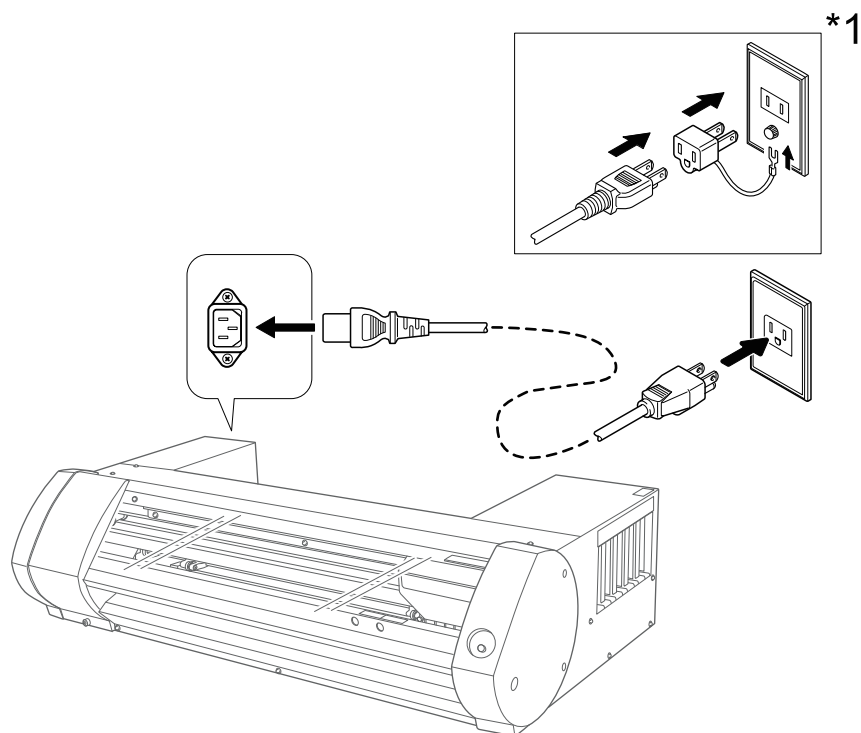

*1: Included only with 100 V specifications

Proceeding to Software Installation

After installing this machine, install the software.

MEMO

The software installation must be performed on a computer.

If you are viewing this manual on your computer

- Click the following URL to check the software installation method.
https://downloadcenter.rolanddg.com/contents/manuals/BN-20D_INS2_EN/index.html

If you are viewing this manual on your mobile device

- Enter the following URL in your computer's web browser.
https://downloadcenter.rolanddg.com/contents/manuals/BN-20D_INS2_EN/index.html

